

## Submersible High Head Drainage Pumps: LH Options and Variations

With more than 35 models of pumps ranging from 3kW to 110kW power output, 50mm to 200 mm discharge, and with newer models being added frequently, this issue of TOPPI will describe about variations and options available in LH pumps.



### Standard LH pumps with single impeller

17 models of pumps ranging from 3kW to 110kW are available as standard pumps in LH series, with discharge bore ranging from 50mm-200mm. All the LH pumps up to 22kW are with Direct Online starting and over 30kW are with Star-Delta starting method.

### LH-W pumps dual Impeller

To achieve higher maximum head of 1.5-2 times with the same motor output as standard LH pumps, Tsurumi LH-W pumps are provided with two impellers. Maximum head of 230m can be achieved with 110kW LH-W pump. As the axial forces are high in this large 110kW pump, the suction is from top and bottom opposite directions for each impeller. This eliminates the axial thrust on the shaft. Due to extreme operating pressure in these pumps, seal pressure relief ports are also provided where necessary.

### LH in tandem\*

Connecting two LH standard pumps or two LH-W dual impeller pumps is the concept of achieving higher head with LH tandem operation. 6 models of 3kW to 30kW LH and LH-W pumps can be fitted with tandem operation kit to achieve maximum head of more than 250m. Due to slim design and central top flow discharge, two LH pumps are suitable to be connected in series with each other to achieve higher head without the need to worry about issues of imbalance in forces.

\*Future issue of TOPPI will introduce selection procedure of LH in tandem operation

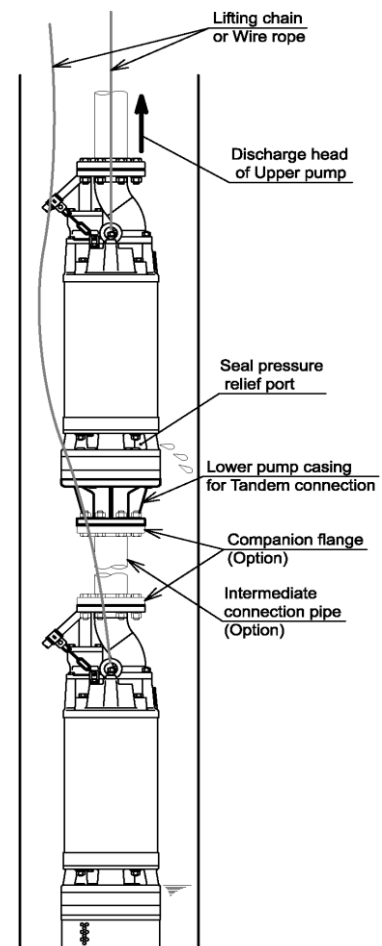

### **All Stainless Steel LH-14 and LH-W-14 pumps**

7 models of standard LH and dual impeller LH-W pumps of 22kW-110kW pumps are made with 316 grade stainless steel casting, as LH-14 and LH-W-14 pumps. All the parts that come into contact with pumping media are made with 316 grade stainless steel to provide robust capabilities of withstanding highly corrosive environment. These pumps are particularly popular and useful in mining industries where the liquid is highly acidic with significantly low level of pH.

### **Seawater-Resistant Version**

Seawater resistant kit of galvanic anode and sweater-resistant special cast iron impeller are available, which can be attached to standard LH pumps of 45kW and dual impeller LH-W pump of 11kW.



### **High Voltage Application**

Often mining sites have irregular high voltage requirements of 690V or 1000V, which are not common for normal application. These pumps also have other specific requirements of shielded cables and built-in diodes on the motors, which are generally not provided with standard pumps. LH pumps can be produced to meet these requirements of high voltages and specific requirements of safety standards.

### **High Temperature Liquid**

Standard Tsurumi pumps are designed to operate with 40°C temperature of pumping liquid. However, there are requirements where the site may be near to volcanic activities, or some other sources of heat that raises the water temperature. For such applications, LH series pumps can be modified to withstand liquid temperature of up to 90°C. (Maximum temperature may differ according the model)