

# Data sheet LH23.0W-50

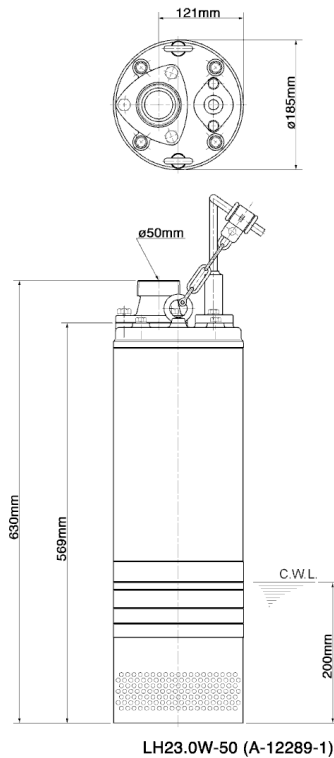

LH23.0W-50 (A-12289-1)

CWL: Continuous running water level

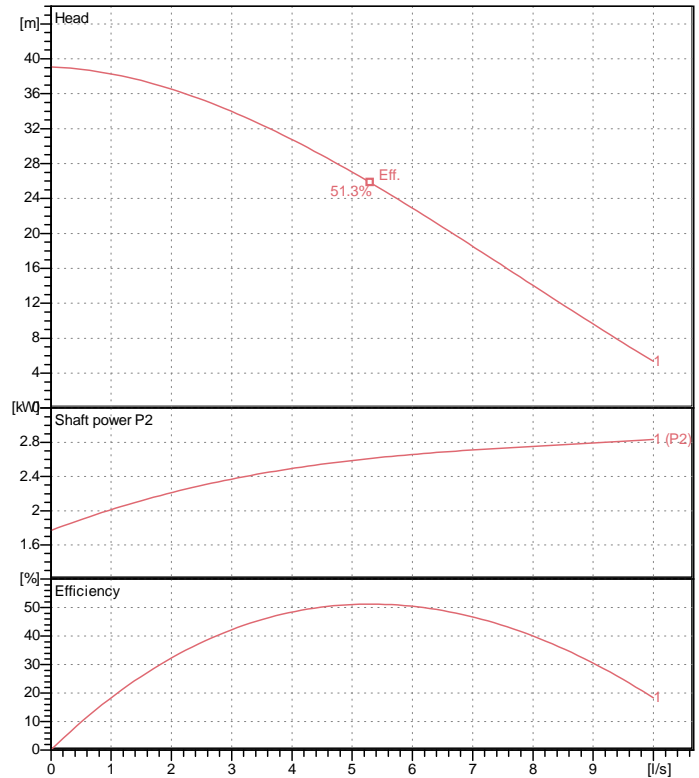

## Specification

Electric submersible pump  
 Degree of protection IP 68  
 Depth of submersion max. 25 m  
 Type of impeller Closed  
 Max. solid handling 6 mm  
 Suitable for:  
 rain water, ground water, sand water

## Electric motor

Dry-type submersible induction motor  
 Insulation class F 2Poles 2820 1/min  
 Starting mode Directly  
 Rated voltage 400 V 50 Hz 3~  
 Power uptake 3.87 kW  
 Rated power 3.00 kW  
 Rated current 6.5 A  
 Start current 45.0 A

## Cable

20m NSSHÖU 4Cx1,5mm<sup>2</sup>

## Motor Protection

Circle thermal protector  
 (snap-action bi-metal device)

## Shaft seal

Double inside mechanical seal in oil bath  
 additional lubrication by oil lifting device

Primary seal  
 Silicon carbide on silicon carbide  
 Secondary seal  
 Silicon carbide on silicon carbide

## Bearings

Shielded ball bearings, maintenance-free

## Materials

Impeller (2x)	Chromium iron casting
Upper Pump casing	FCD45 (EN-GJS-450-10)
Middle Pump casing	FCD45 (EN-GJS-450-10)
Motor Frame	Grey iron casting
Shaft	SUS420J2 (EN-X30Cr13)

## Discharge size

2" (50mm) BS-Coupling (threaded flange)

## Weight

46 kg (dry weight of the pump only without cable)

# Performance curve LH23.0W-50

Discharge port	2"
Head	39.1 m
Flow	10.0 l/s
Rated power	3.00 kW
Power input	3.87 kW
Phases	3~
Voltages	400 V
Frequency	50 Hz
Rated current	6.5 A
Starting current	44.98 A
Number of poles	2
Speed	2820 1/min
Starting mode	Directly
Insulation class	F

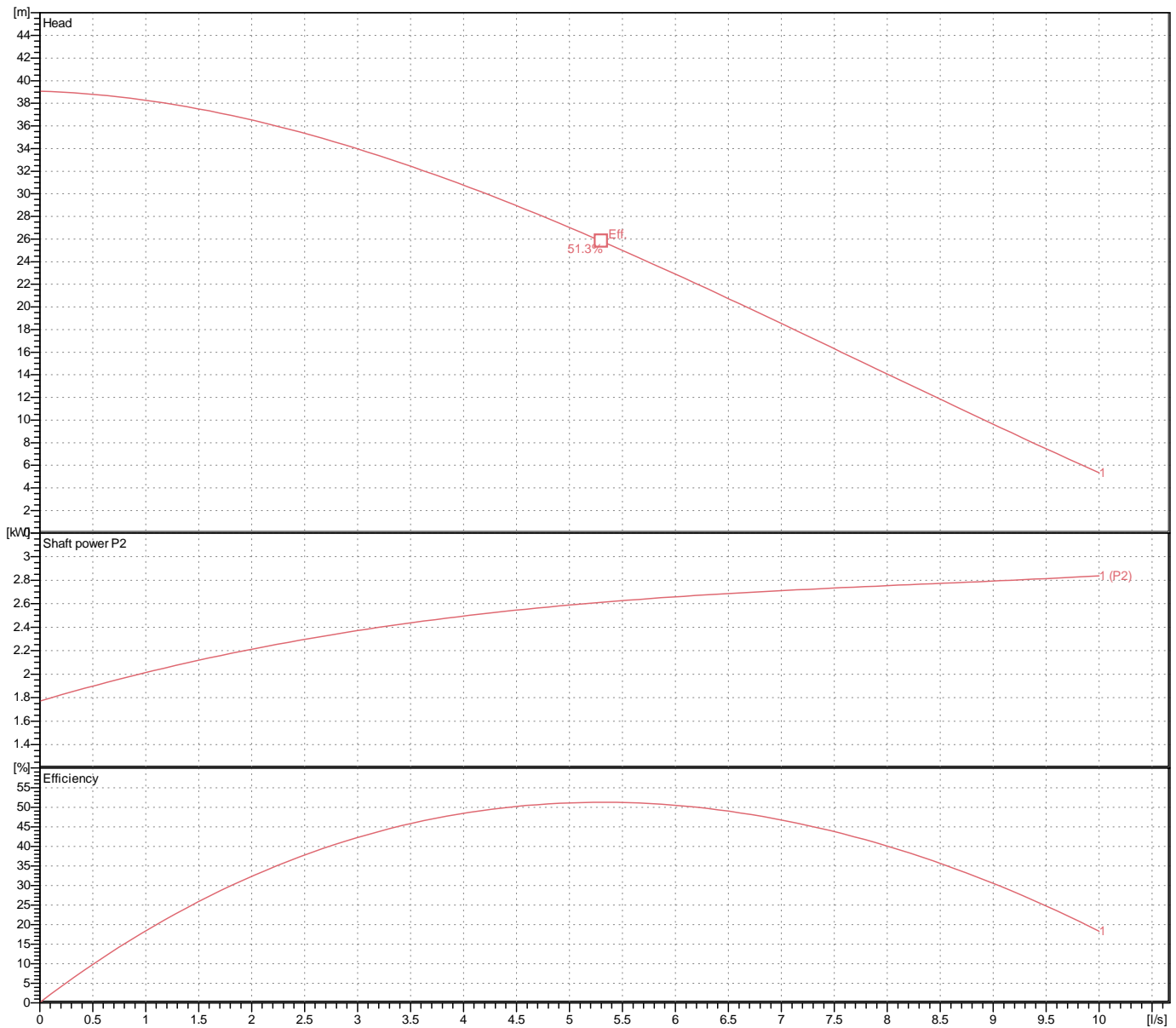

# Dimensions LH23.0W-50

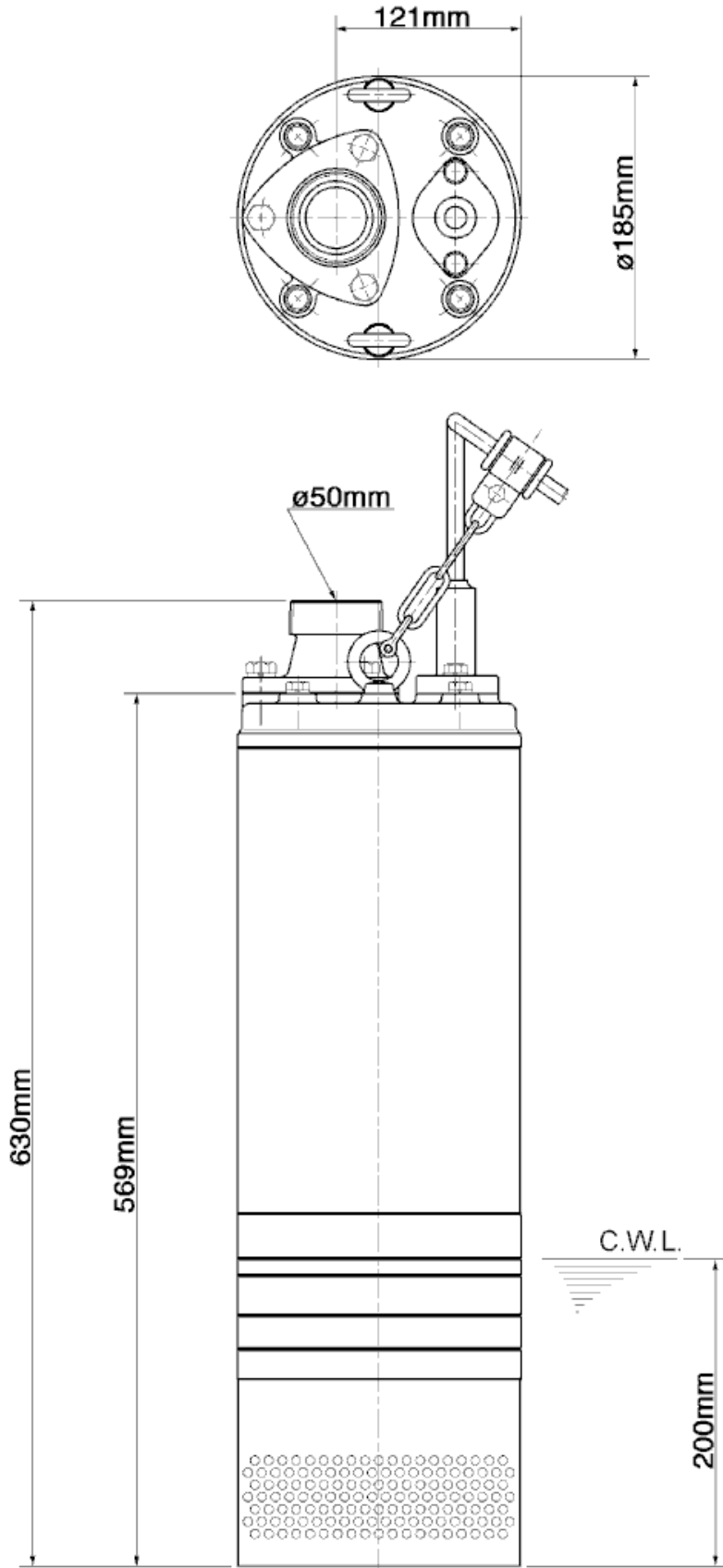

LH23.0W-50 (A-12289-1)

CWL: Continuous running water level  
LWL: Lowest running water level

 **TSURUMI PUMP**

Tsurumi Europe GmbH  
15.10.2018 V.18 / 1.10.2015

Heltorfer Str. 14 \* 40472 Düsseldorf \* Germany  
Tel.: +49-211-4179373 sales@tsurumi.eu  
Fax: +49-211-417937-480 www.tsurumi.eu

# Sectional drawing LH23.0W-50

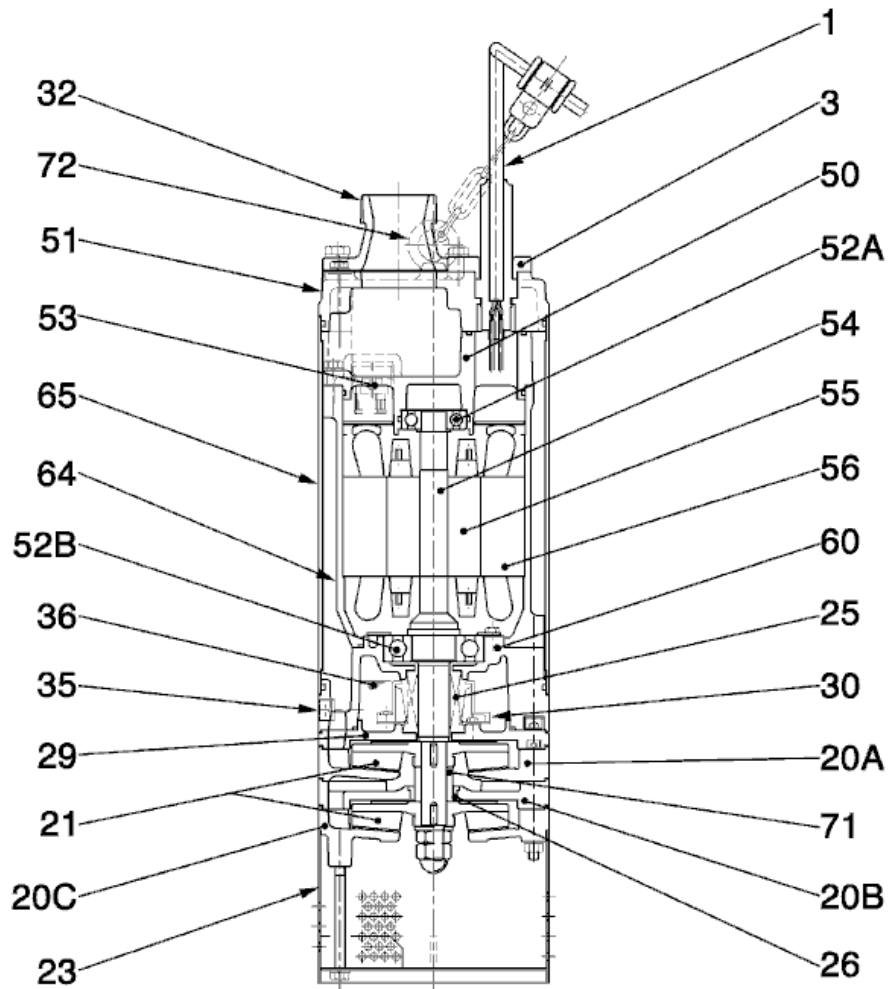

LH23.0W-50 (A-12293-1)

No.	Description	Remark	No.	Description	Remark
1	Cable	20m NSSHÖU	52A	Upper bearing	6304ZZC3
3	Gland	Grey iron casting	52B	Lower bearing	6307ZZC3
20A	Upper Pump casing	FCD45 (EN-GJS-450-10)	53	Motor Protector 380/400/415V-50Hz KA314-HRXL00 (H.C)	
20B	Middle Pump casing	FCD45 (EN-GJS-450-10)	54	Shaft	SUS420J2 (EN-X30Cr13)
20C	Lower Pump casing	FCD45 (EN-GJS-450-10)	55	Rotor	.
21	Impeller (2x)	Chromium iron casting	56	Stator	.
23	Strainer	Steel plate	60	Bearing Housing	Grey iron casting
25	Mechanical seal	H-25T	64	Motor Frame	Grey iron casting
26	Wear Ring	SUS304 (EN-X5CrNi18-10)	65	Outer Cover	Steel plate
29	Oil casing	Nodular graphite iron	71	Shaft protection sleeve	SUS403 (EN-X6Cr13)
30	Oil distributor	Plastic	72	Eye screw (2x)	SUS304 (EN-X5CrNi18-10)
32	Hose coupling	Nodular graphite iron			
35	Oil plug	SUS304 (EN-X5CrNi18-10)			
36	Lubricant	Turbine oil (ISO VG32)			
50	Motor cover	Grey iron casting			
51	Main cover	Grey iron casting			