

Data sheet NK3-22L

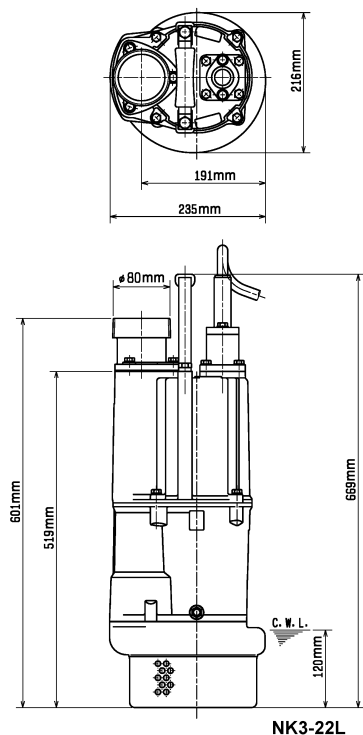

CWL: Continuous running water level

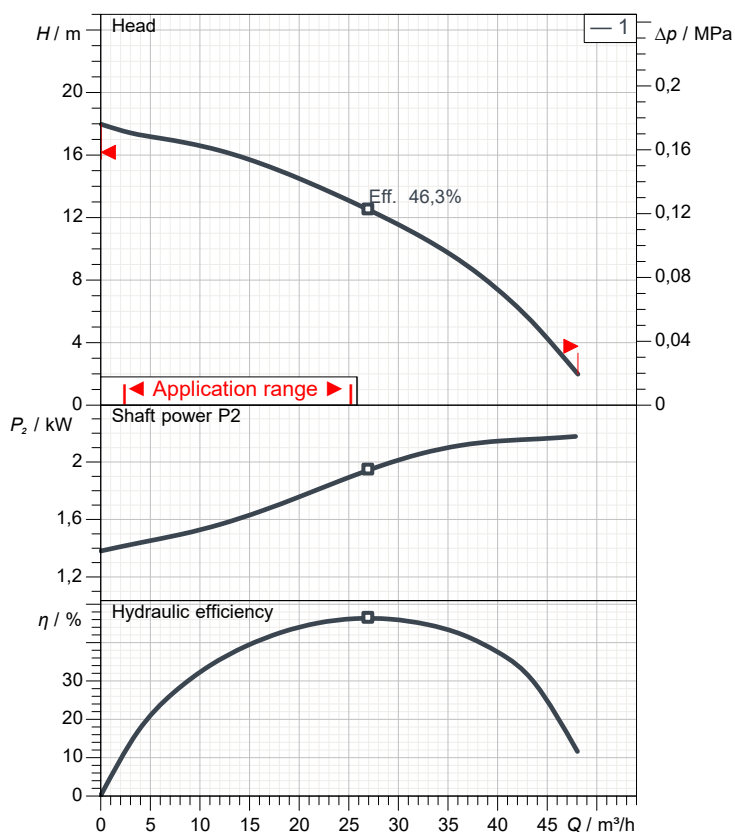

Specification

Electric submersible pump NK-series
 Degree of protection IP 68
 Pressure resistance max. 25 m
 Type of impeller semi-vortex
 Max. solid handling 6 mm
 Suitable for:
 spring-/rain-/font water, water containing sand

Electric motor

Dry-type submersible induction motor
 Insulation class E 2Poles 2.890 1/min
 Starting mode
 Rated voltage 230 V 50 Hz 1~
 Power uptake 3,20 kW
 Rated power 2,20 kW
 Rated current 14,5 A
 Start current 69,0 A

Cable

20m H07RN8-F 3Cx2,5mm²

Motor Protection

Circle thermal protector
 (snap-action bi-metal device)

Shaft seal

Double inside mechanical seal in oil bath
 additional lubrication by oil lifting device
 Primary seal
 Silicon carbide on silicon carbide
 Secondary seal
 Silicon carbide on silicon carbide

Bearings

Shielded ball bearings, maintenance-free

Materials

Impeller	Chromium Iron HiCrFC
Pump casing	FC200 (EN-GJL-200)
Motor Frame	Aluminium alloy casting
Shaft	SUS420J2 (EN-X30Cr13)

Discharge size

3" (80mm) BS-Coupling / Hose Coupling (optional)

Weight

40 kg (dry weight of the pump only without cable)

Performance curve

NK3-22L

Discharge port	3"
Head	18,0 m
Flow	48,1 m ³ /h
Rated power	2,20 kW
Power input	3,20 kW
Phases	1~
Voltages	230 V
Frequency	50 Hz
Rated current	14,5 A
Starting current	69,00 A
Number of poles	2
Speed	2.890 1/min
Starting mode	
Insulation class	E

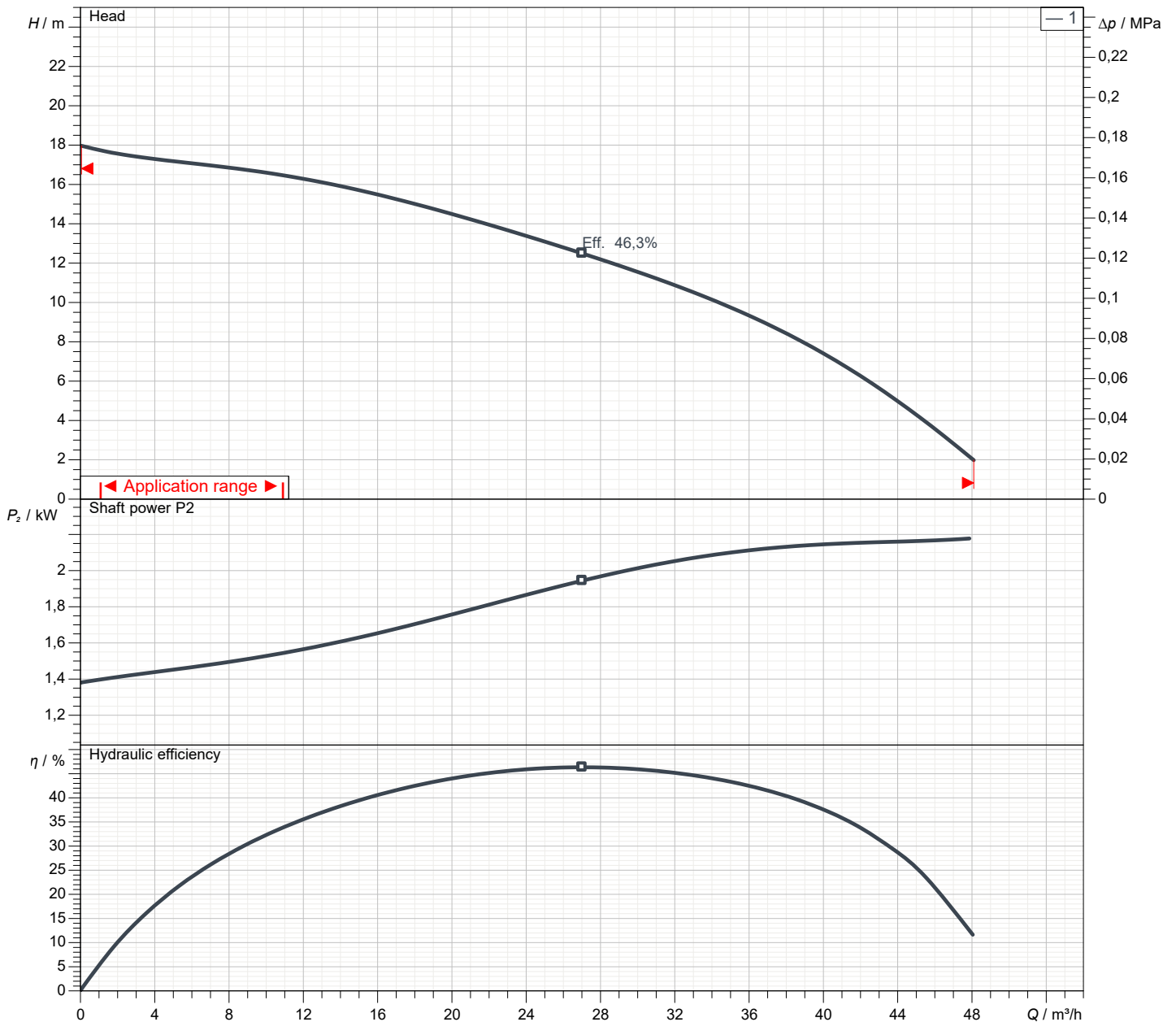

Dimensions

NK3-22L

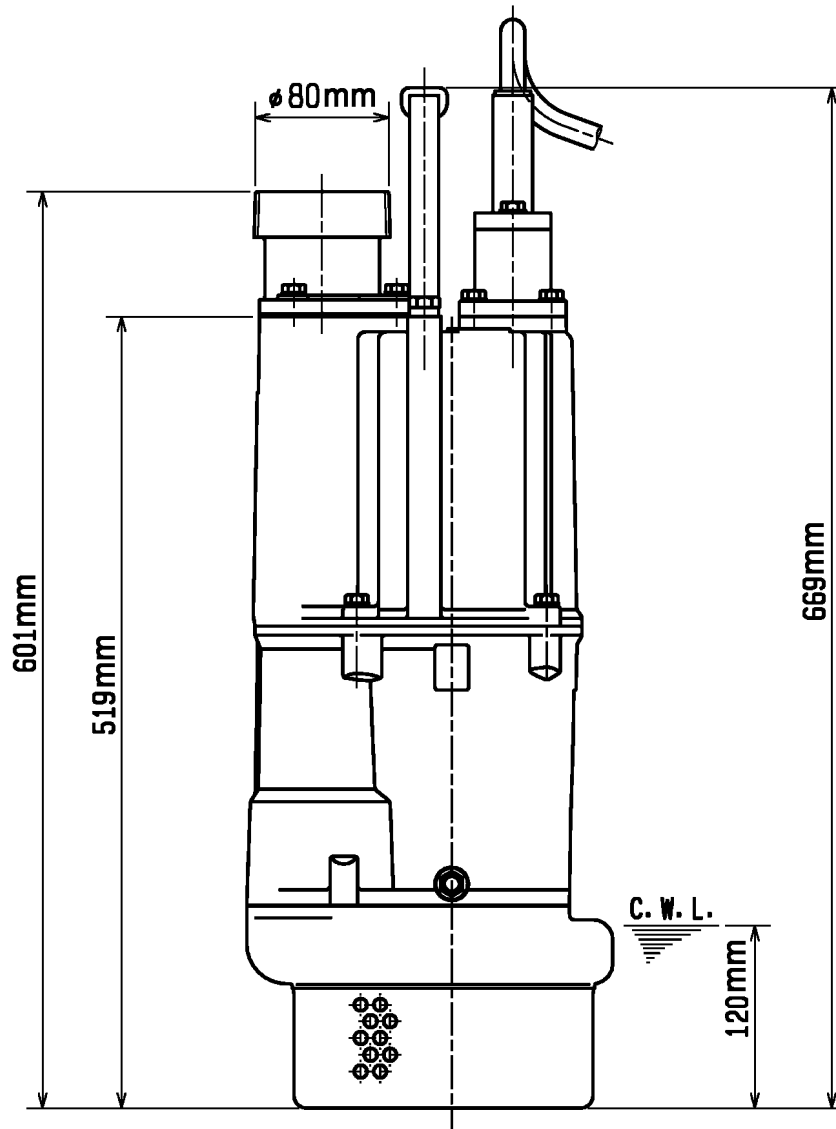
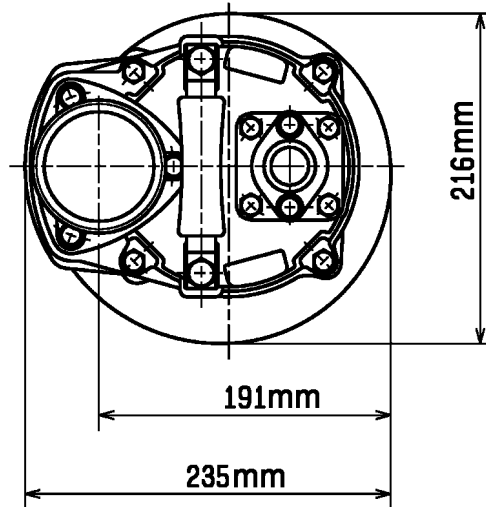

NK3-22L

CWL: Continuous running water level
LWL: Lowest running water level

Sectional drawing NK3-22L

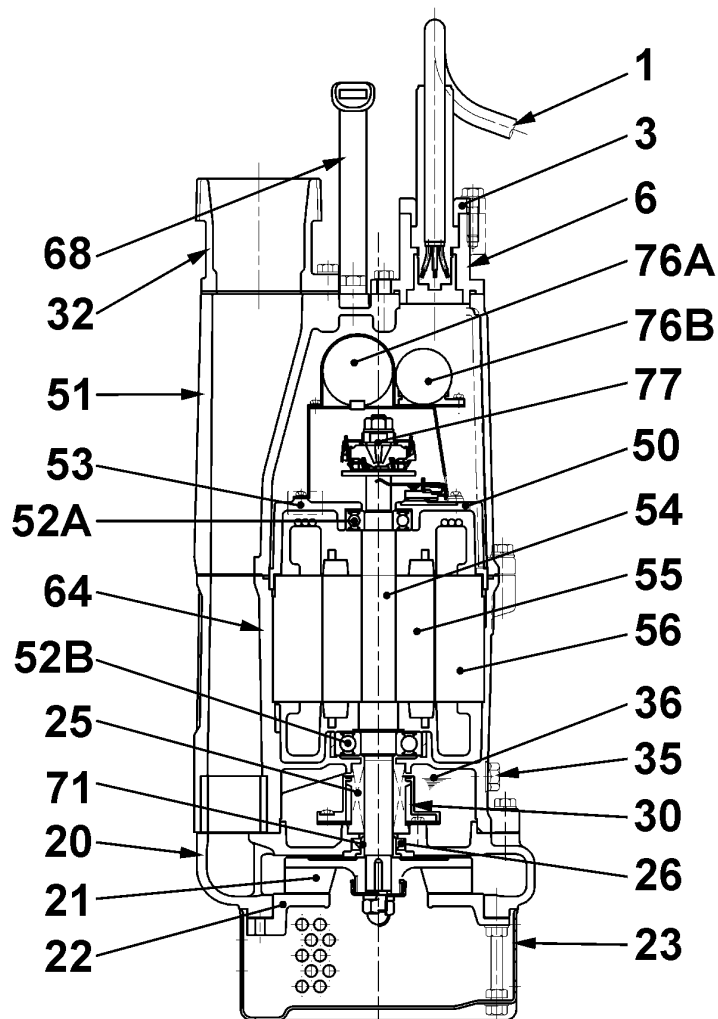

NK3-22L

No.	Description	Remark	No.	Description	Remark
1	Cable	H07RN-F	52B	Lower bearing	6305ZC3
3	Gland	Aluminium die casting	53	Motor Protector 380/400/415V-50Hz	KA314-HRXL00 (H.C)
6	Cable entry	Aluminium alloy casting	54	Shaft	SUS420J2 (EN-X30Cr13)
20	Pump casing	FC200 (EN-GJL-200)	55	Rotor	.
21	Impeller	Chromium Iron HiCrFC	56	Stator	.
22	Suction cover	FCD45 (EN-GJS-450-10)	64	Motor Frame	Aluminium alloy casting
23	Strainer	Steel plate	68	Handle	Steelplate and rubber
25	Mechanical seal	H-20T	71	Shaft protection sleeve	SUS304 (EN-X5CrNi18-10)
26	Oil seal	TC25388	76A	Condenser	.
30	Oil distributor	Plastic	76B	Condenser	.
32	Discharge coupling	FC200 (EN-GJL-200)	77	Centrifugal force switch	.
35	Oil screw	SUS304 (EN-X5CrNi18-10)			
36	Lubricant	Turbine oil (ISO VG32)			
50	Motor cover	FC200 (EN-GJL-200)			
51	Main cover	Aluminium alloy casting			
52A	Upper bearing	6204ZC3			