

# Data sheet KTZE33.7-51

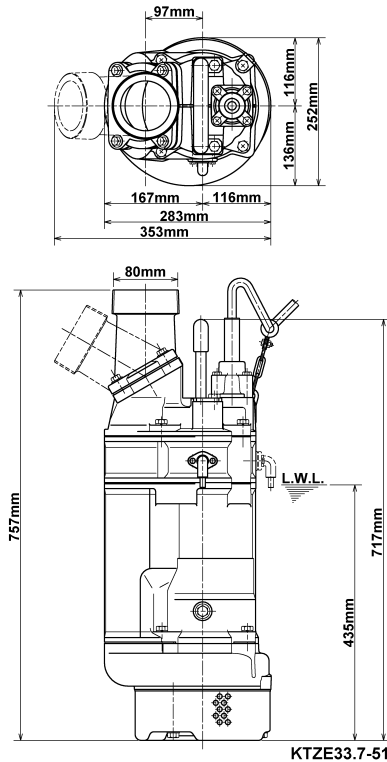

CWL: Continuous running water level

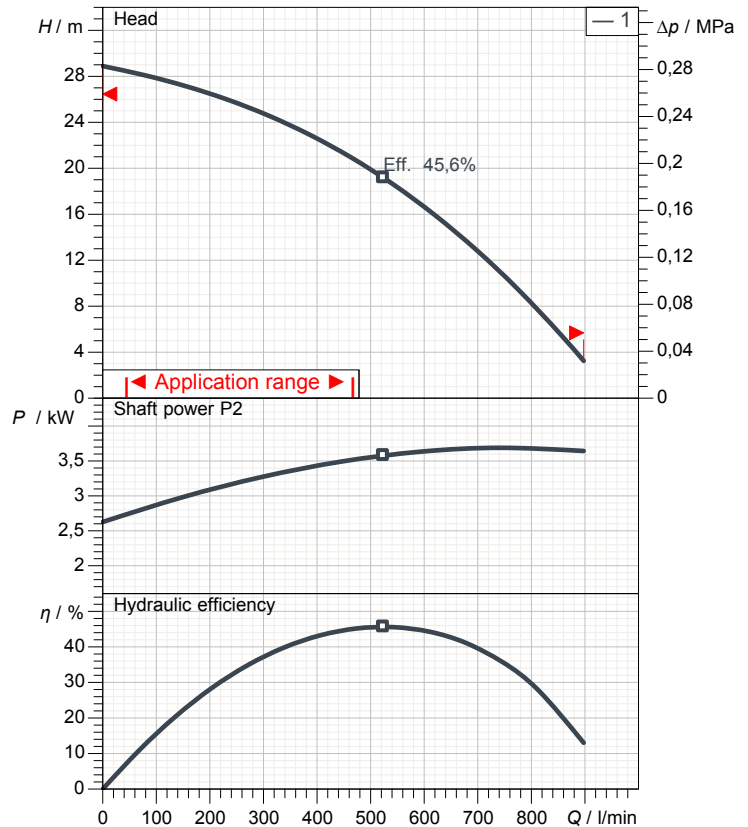

## Specification

Electric submersible pump KTZE-series  
 Degree of protection IP 68  
 Pressure resistance max. 25 m  
 Type of impeller Semi-open  
 Max. solid handling 8,5 mm  
 Suitable for:  
 spring-/rain-/waste-/ground water, water containing sand

## Electric motor

Dry-type submersible induction motor  
 Insulation class F 2Poles 2850 1/min  
 Starting mode Direct starting  
 Rated voltage 400 V 50 Hz 3~  
 Power uptake 4,91 kW  
 Rated power 3,70 kW  
 Rated current 7,7 A  
 Start current 58,0 A

## Cable

20m NSSHÖU 4Cx1,5mm<sup>2</sup>

## Motor Protection

Circle thermal protector  
 (snap-action bi-metal device)

## Shaft seal

Double inside mechanical seal in oil bath  
 additional lubrication by oil lifting device  
 Primary seal  
 Silicon carbide on silicon carbide  
 Secondary seal  
 Silicon carbide on carbon

## Bearings

Shielded ball bearings, maintenance-free

## Materials

Impeller	Chromium Iron HiCrFC
Pump casing	FC200 (EN-GJL-200)
Suction cover	FCD50 (EN-GJS-500-7)
Motor Frame	FC150 (EN-GJL-150)
Shaft	SUS420J2 (EN-X30Cr13)

## Discharge size

3" (80mm) BS-coupling (threaded flange)

## Weight

71 kg (dry weight of the pump only without cable)

# Performance curve

## KTZE33.7-51

Discharge port	3"
Head	28,9 m
Flow	897,6 l/min
Rated power	3,70 kW
Power input	4,91 kW
Phases	3~
Voltages	400 V
Frequency	50 Hz
Rated current	7,7 A
Starting current	57,98 A
Number of poles	2
Speed	2850 1/min
Starting mode	Direct starting
Insulation class	F

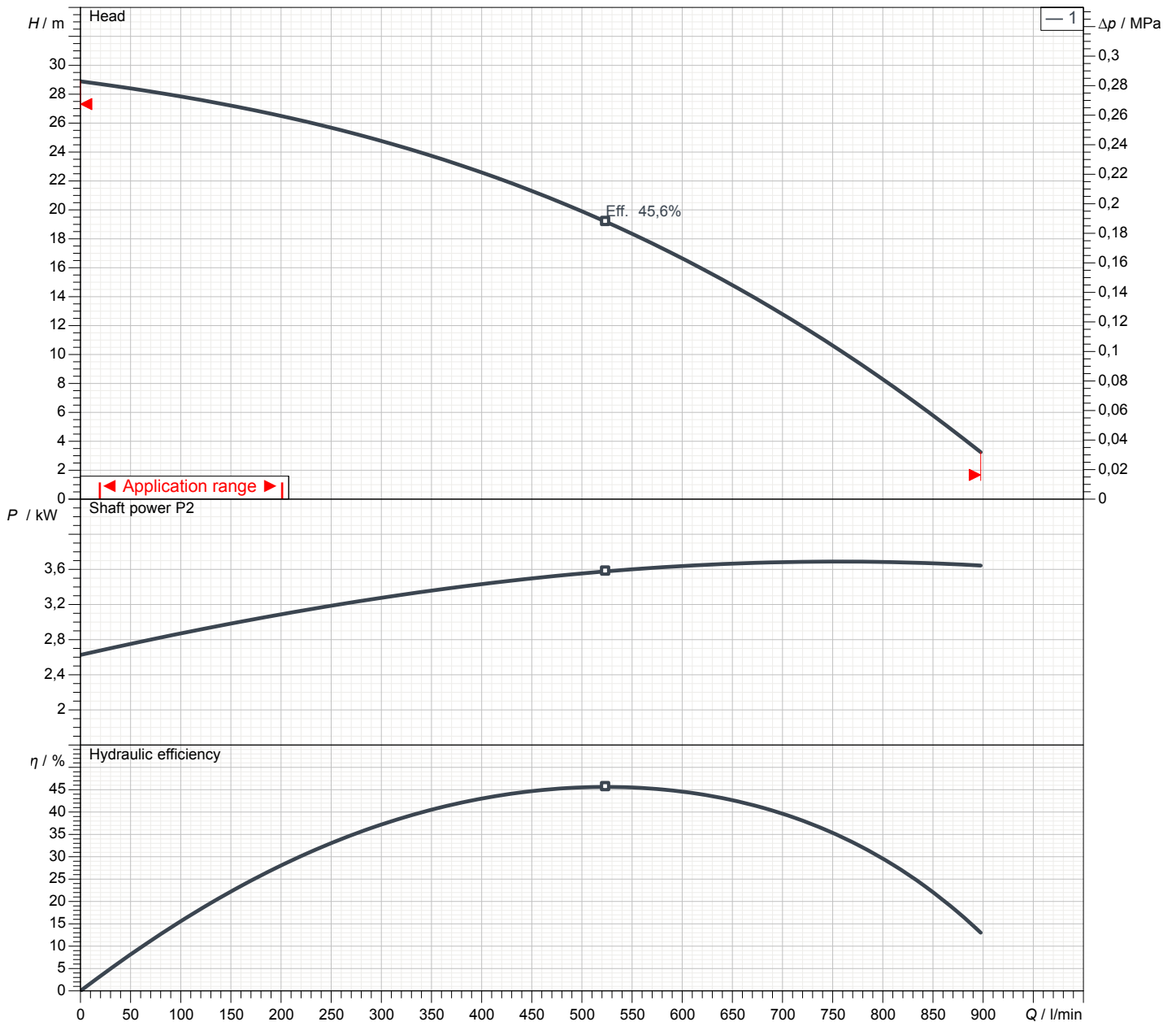

# Dimensions

## KTZE33.7-51

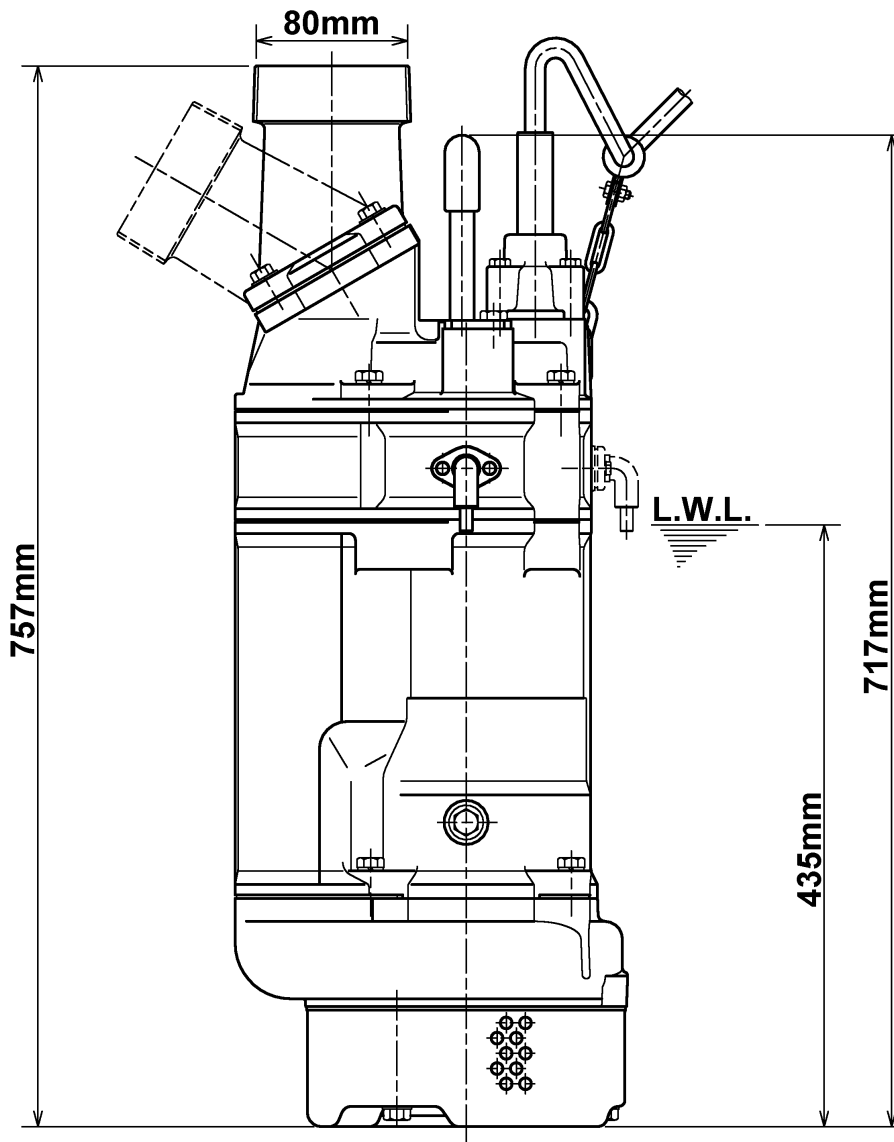
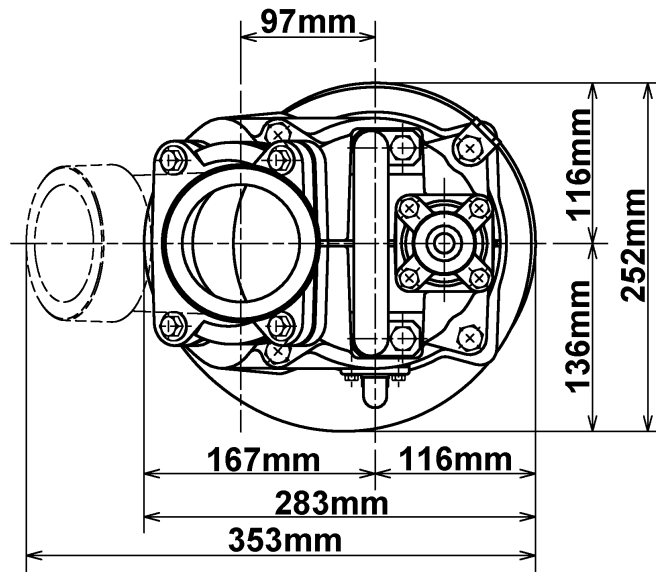

**KTZE33.7-51**

**CWL: Continuous running water level**  
**LWL: Lowest running water level**

# Sectional drawing KTZE33.7-51

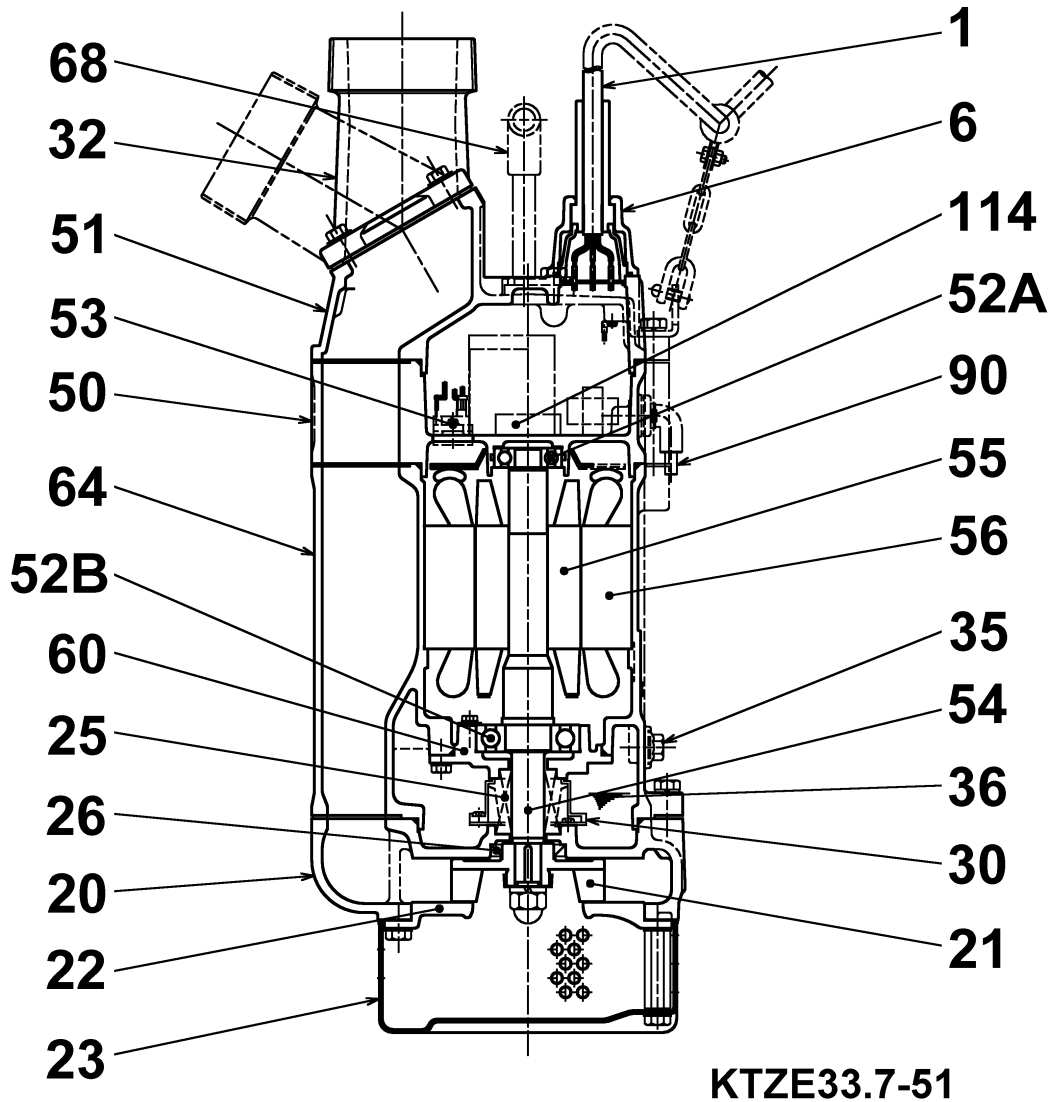

No.	Description	Remark	No.	Description	Remark
1	Cable	20m NSSHÖU	53	Motor Protector 380/400/415V-50Hz.KA314-HRXL00 (H.C)	
6	Stuffing box	FC200 (EN-GJL-200)	54	Shaft	SUS420J2 (EN-X30Cr13)
20	Pump casing	FC200 (EN-GJL-200)	55	Rotor	.
21	Impeller	Chromium Iron HiCrFC	56	Stator	.
22	Suction cover	FCD50 (EN-GJS-500-7)	60	Bearing Housing	FC150 (EN-GJL-150)
23	Strainer	Steel plate	64	Motor Frame	FC150 (EN-GJL-150)
25	Mechanical seal	H-25T	68	Handle	steel pipe / Sectional steel
26	Oil seal	TC40588	71	Shaft protection sleeve	SUS304 (EN-X5CrNi18-10)
30	Oil distributor	Plastic	90	Electrode	.
32	Discharge coupling	FC200 (EN-GJL-200)	114	Relais	.
35	Oil screw	SUS304 (EN-X5CrNi18-10)			
36	Lubricant	Turbine oil (ISO VG32)			
50	Lower motor cover	FC150 (EN-GJL-150)			
51	Upper motor cover	FC150 (EN-GJL-150)			
52A	Upper bearing	6304ZZC3			
52B	Lower bearing	6307ZZC3			