

Data sheet KTZE22.2-51

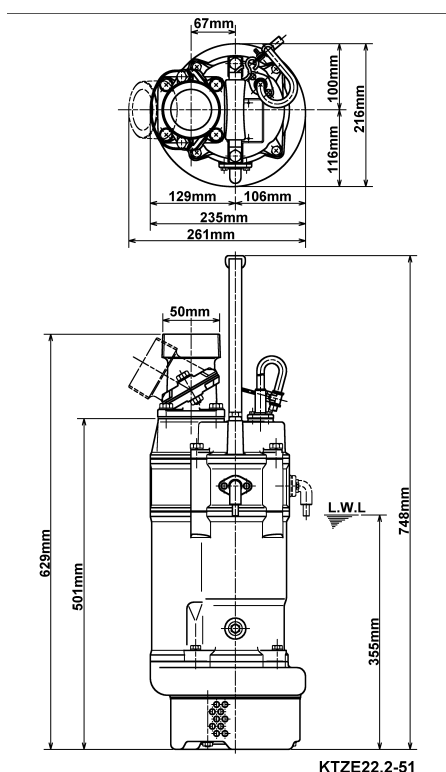

CWL: Continuous running water level

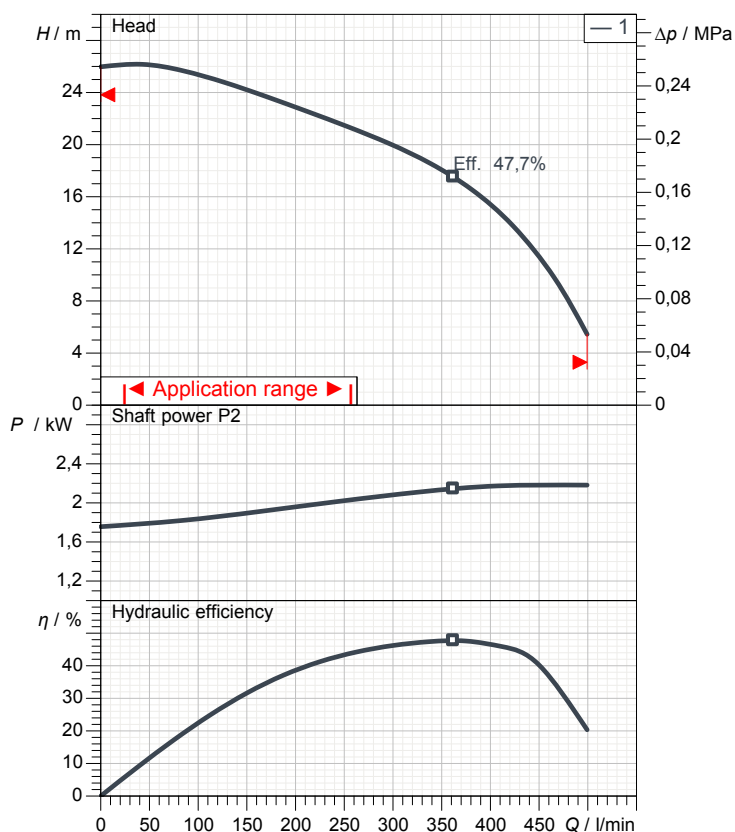

Specification

Electric submersible pump KTZE-series
 Degree of protection IP 68
 Pressure resistance max. 25 m
 Type of impeller Semi-open
 Max. solid handling 8,5 mm
 Suitable for:
 spring-/rain-/waste-/ground water, water containing sand

Electric motor

Dry-type submersible induction motor
 Insulation class F 2Poles 2840 1/min
 Starting mode Direct starting
 Rated voltage 400 V 50 Hz 3~
 Power uptake 3,15 kW
 Rated power 2,20 kW
 Rated current 5 A
 Start current 35,0 A

Cable

20m NSSHÖU 4Cx1,5mm²

Motor Protection

Circle thermal protector
 (snap-action bi-metal device)

Shaft seal

Double inside mechanical seal in oil bath
 additional lubrication by oil lifting device
 Primary seal
 Silicon carbide on silicon carbide
 Secondary seal
 Silicon carbide on silicon carbide

Bearings

Shielded ball bearings, maintenance-free

Materials

Impeller	Chromium Iron HiCrFC
Pump casing	FC200 (EN-GJL-200)
Suction cover	FCD50 (EN-GJS-500-7)
Motor Frame	FC150 (EN-GJL-150)
Shaft	SUS420J2 (EN-X30Cr13)

Discharge size

2" (50mm) BS-Coupling (threaded flange)

Weight

42 kg (dry weight of the pump only without cable)

Performance curve

KTZE22.2-51

Discharge port	2"
Head	26,0 m
Flow	499,3 l/min
Rated power	2,20 kW
Power input	3,15 kW
Phases	3~
Voltages	400 V
Frequency	50 Hz
Rated current	5 A
Starting current	35,00 A
Number of poles	2
Speed	2840 1/min
Starting mode	Direct starting
Insulation class	F

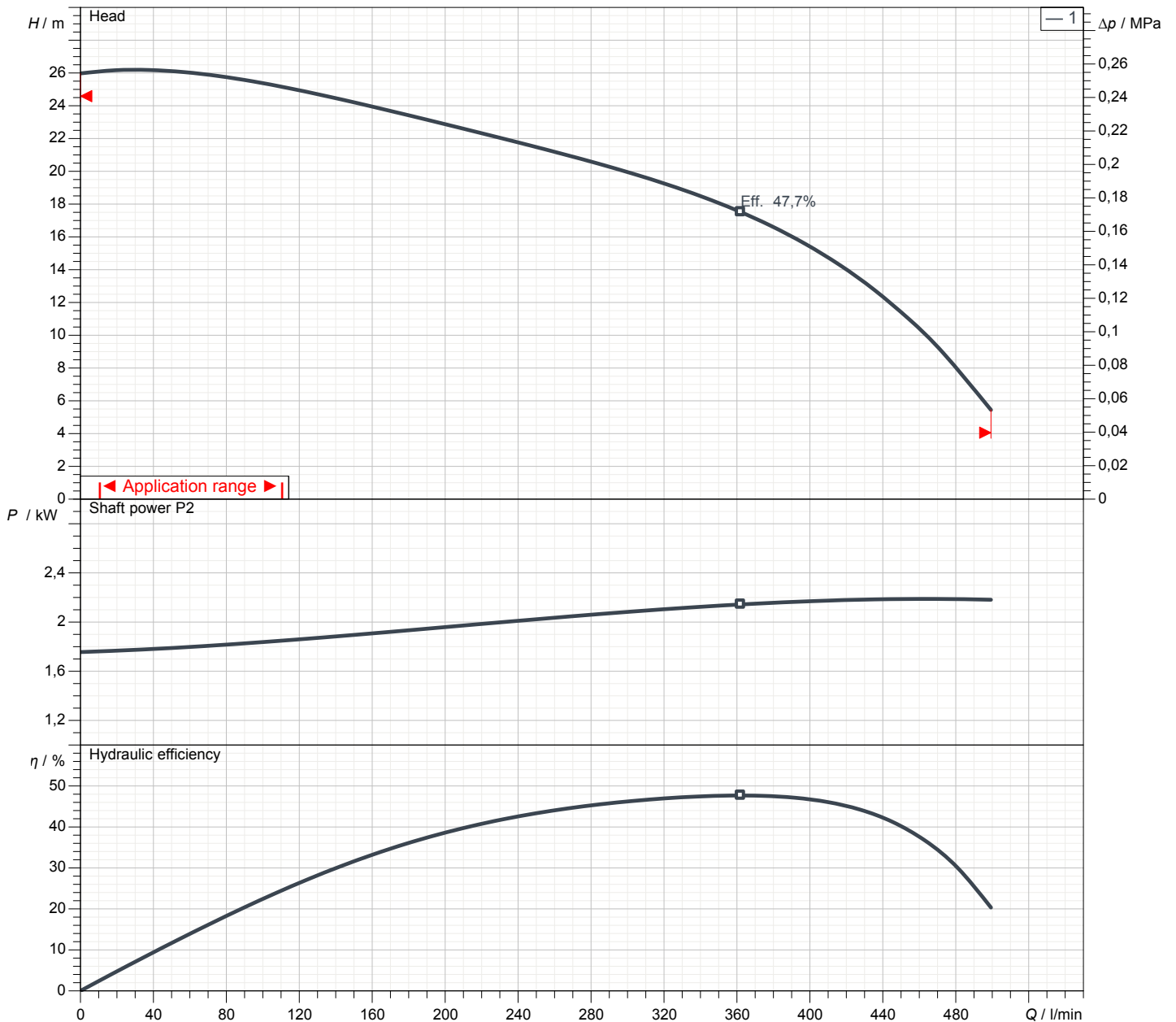

Dimensions

KTZE22.2-51

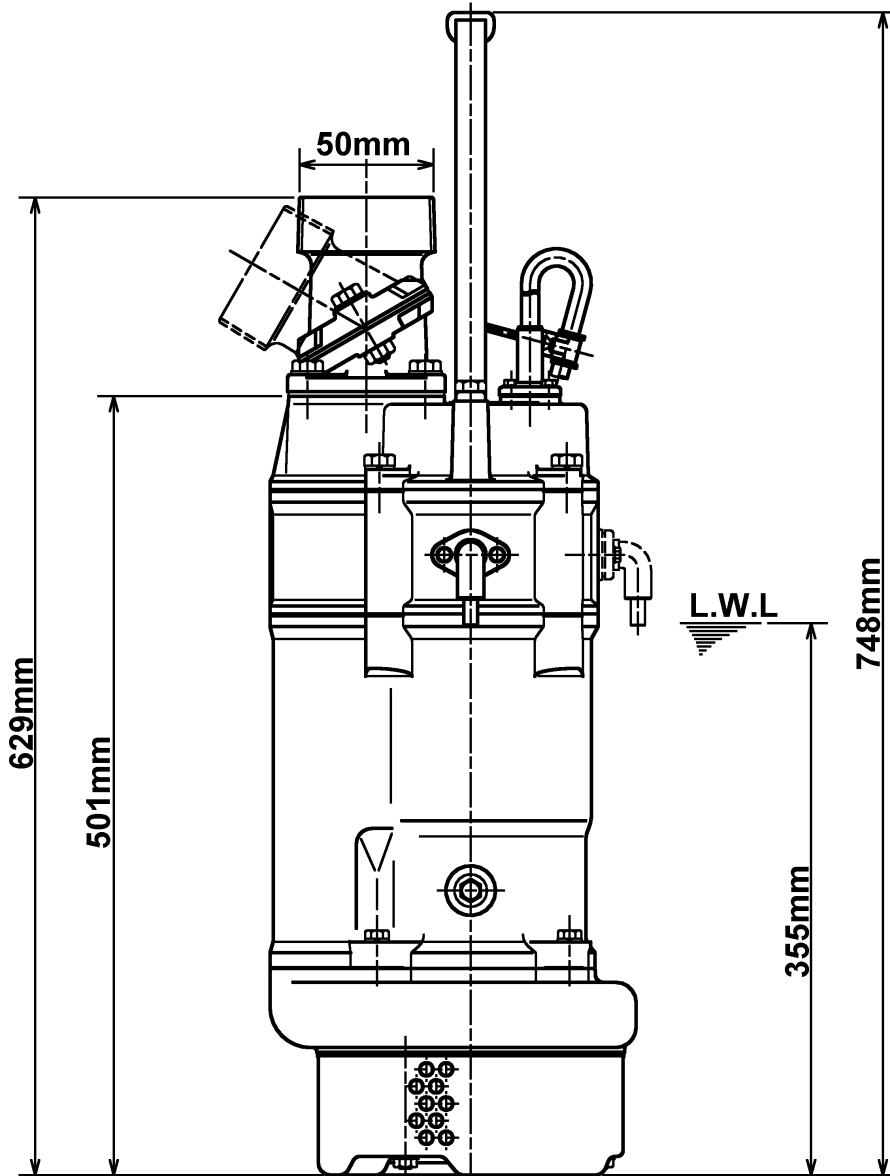
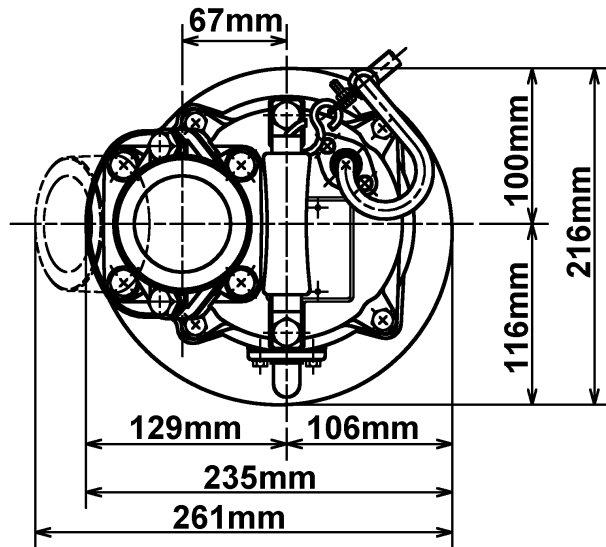

KTZE22.2-51

CWL: Continuous running water level
LWL: Lowest running water level

Sectional drawing KTZE22.2-51

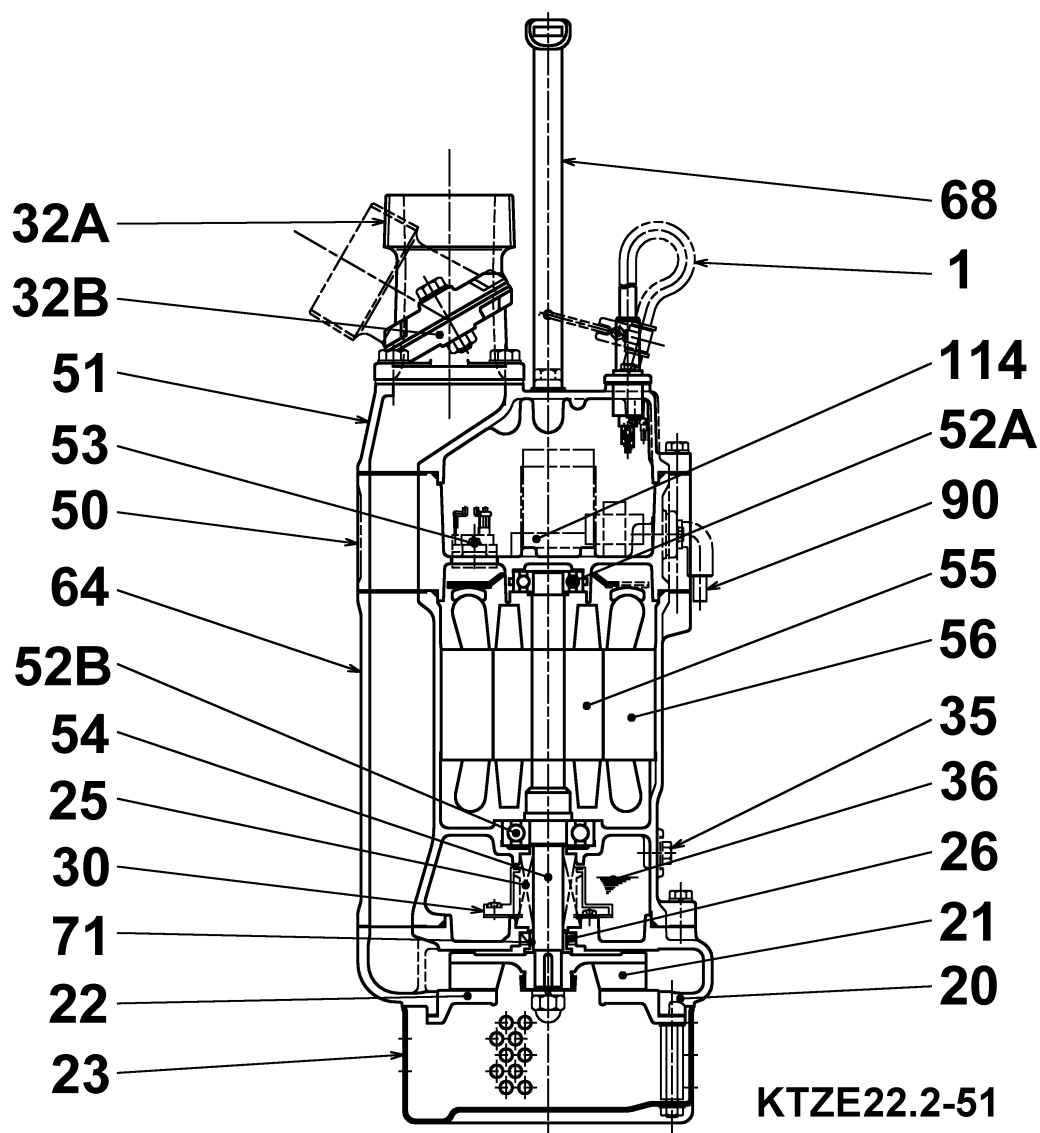

No.	Description	Remark	No.	Description	Remark
1	Cable	20m NSSHÖU	53	Motor Protector 380/400/415V-50Hz.KA314-HRXL00 (H.C)	
20	Pump casing	FC200 (EN-GJL-200)	54	Shaft	SUS420J2 (EN-X30Cr13)
21	Impeller	Chromium Iron HiCrFC	55	Rotor	.
22	Suction cover	FCD50 (EN-GJS-500-7)	56	Stator	.
23	Strainer	Steel plate	64	Motor Frame	FC150 (EN-GJL-150)
25	Mechanical seal	H-20T	68	Handle	Steelplate and rubber
26	Oil seal	TC25388	71	Shaft protection sleeve	SUS304 (EN-X5CrNi18-10)
30	Oil distributor	Plastic	90	Electrode	.
32A	Discharge coupling (1/2)	FC200 (EN-GJL-200)	114	Relais	.
32B	Discharge coupling (2/2)	Aluminium die casting			
35	Oil screw	SUS304 (EN-X5CrNi18-10)			
36	Lubricant	Turbine oil (ISO VG32)			
50	Lower motor cover	FC150 (EN-GJL-150)			
51	Upper motor cover	FC150 (EN-GJL-150)			
52A	Upper bearing	6204ZZC3			
52B	Lower bearing	6305ZZC3			