

Data sheet KRS822L-51

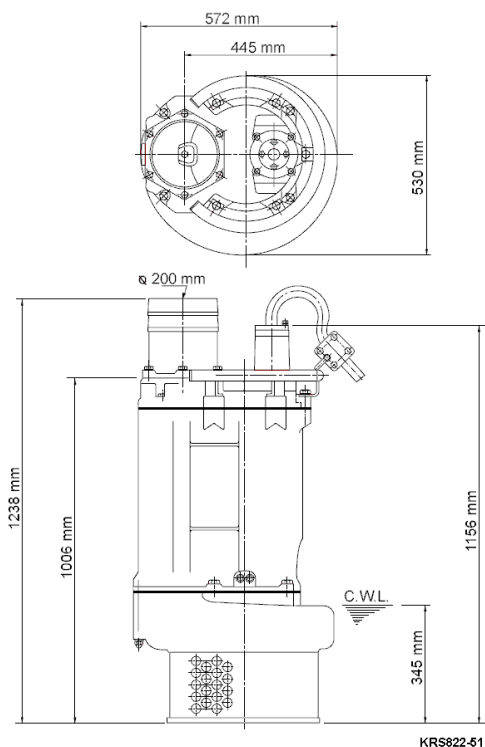

CWL: Continuous running water level

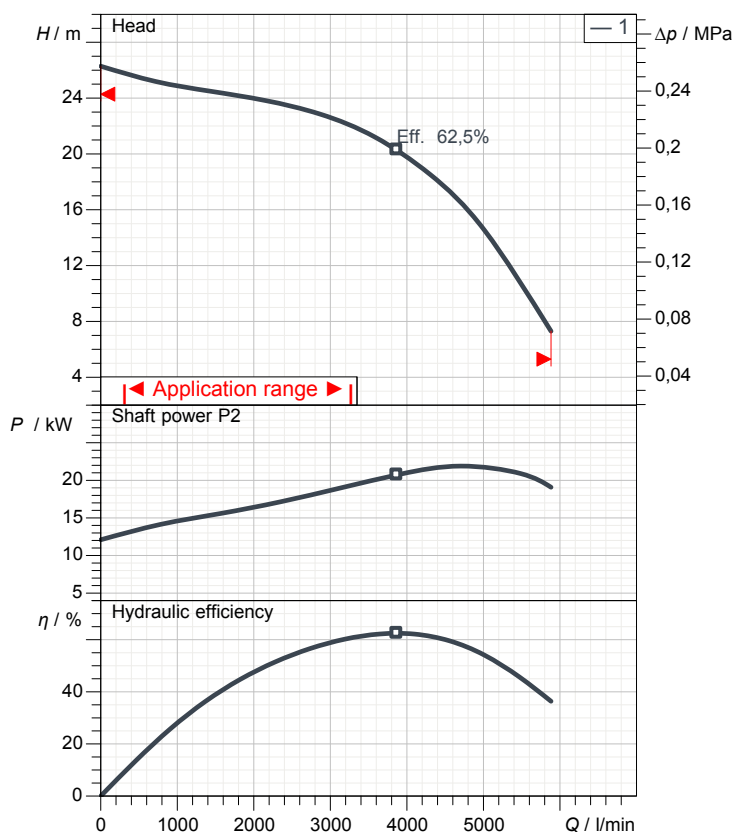

Specification

Electric submersible pump KRS-series
 Degree of protection IP 68
 Pressure resistance max. 20 m
 Type of impeller Semi-open
 Max. solid handling 25 mm
 Suitable for:
 rain water, ground water, sand water

Electric motor

Dry-type submersible induction motor
 Insulation class F 4Poles 1455 1/min
 Starting mode Direct starting
 Rated voltage 400 V 50 Hz 3~
 Power uptake 27,09 kW
 Rated power 22,00 kW
 Rated current 44,6 A
 Start current 316,2 A

Cable

20m NSSHÖU 4Cx10mm²

Motor Protection

Circle thermal protector
 (snap-action bi-metal device)

Shaft seal

Double inside mechanical seal in oil bath
 additional lubrication by oil lifting device
 Primary seal
 Silicon carbide on silicon carbide
 Secondary seal
 Silicon carbide on silicon carbide

Bearings

Shielded ball bearings, maintenance-free

Materials

Impeller	FCD700 (EN-GJS-700-2)
Pump casing	FC200 (EN-GJL-200)
Suction cover	FC200 (EN-GJL-200)
Motor Frame	FC200 (EN-GJL-200)
Shaft	SUS420J2 (EN-X30Cr13)

Discharge size

8" (200mm) hose coupling

Weight

380 kg (dry weight of the pump only without cable)

Performance curve

KRS822L-51

Discharge port	8"
Head	26,3 m
Flow	5882,8 l/min
Rated power	22,00 kW
Power input	27,09 kW
Phases	3~
Voltages	400 V
Frequency	50 Hz
Rated current	44,6 A
Starting current	316,21 A
Number of poles	4
Speed	1455 1/min
Starting mode	Direct starting
Insulation class	F

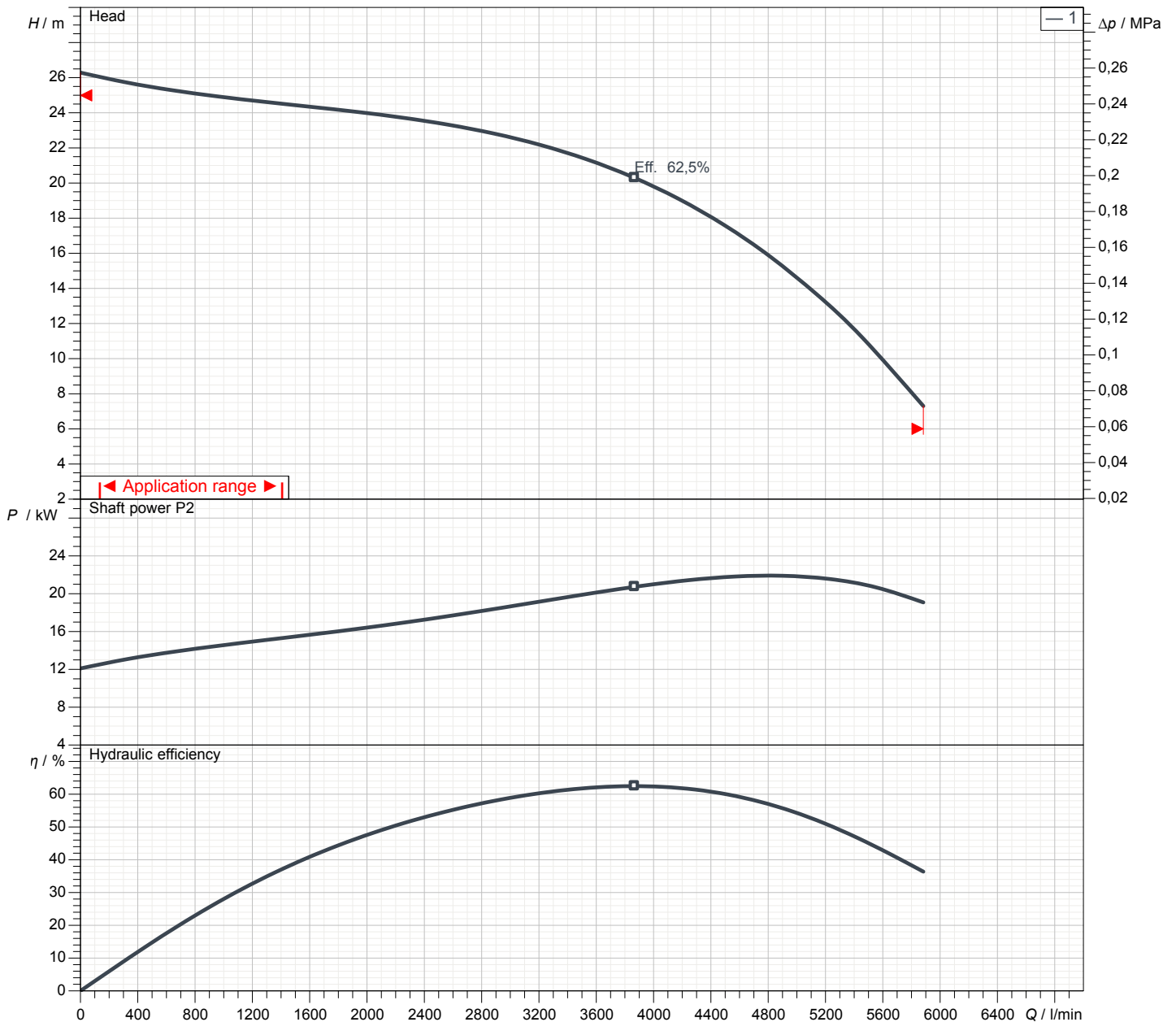

Dimensions

KRS822L-51

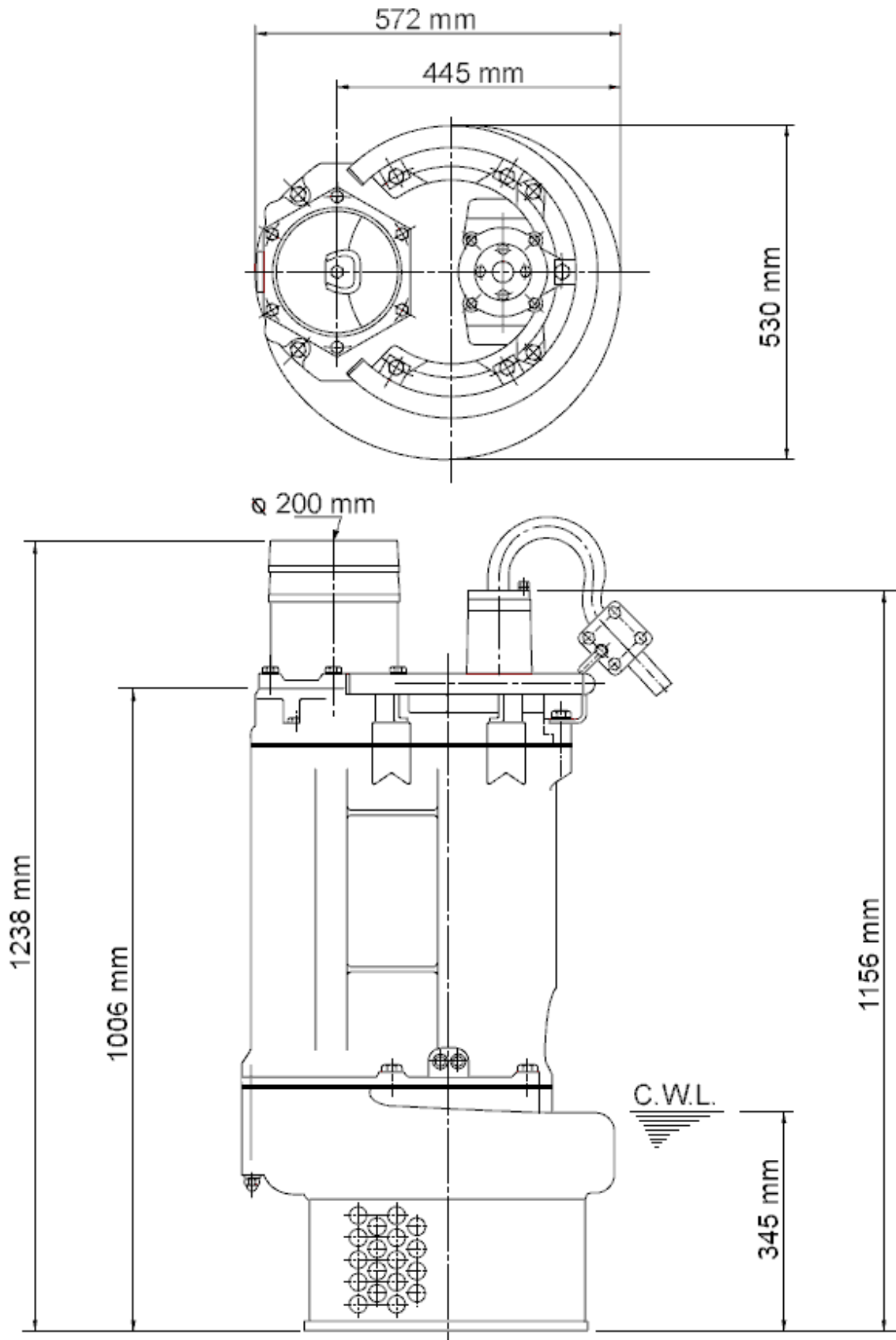

KRS822-51

CWL: Continuous running water level
 LWL: Lowest running water level

Sectional drawing KRS822L-51

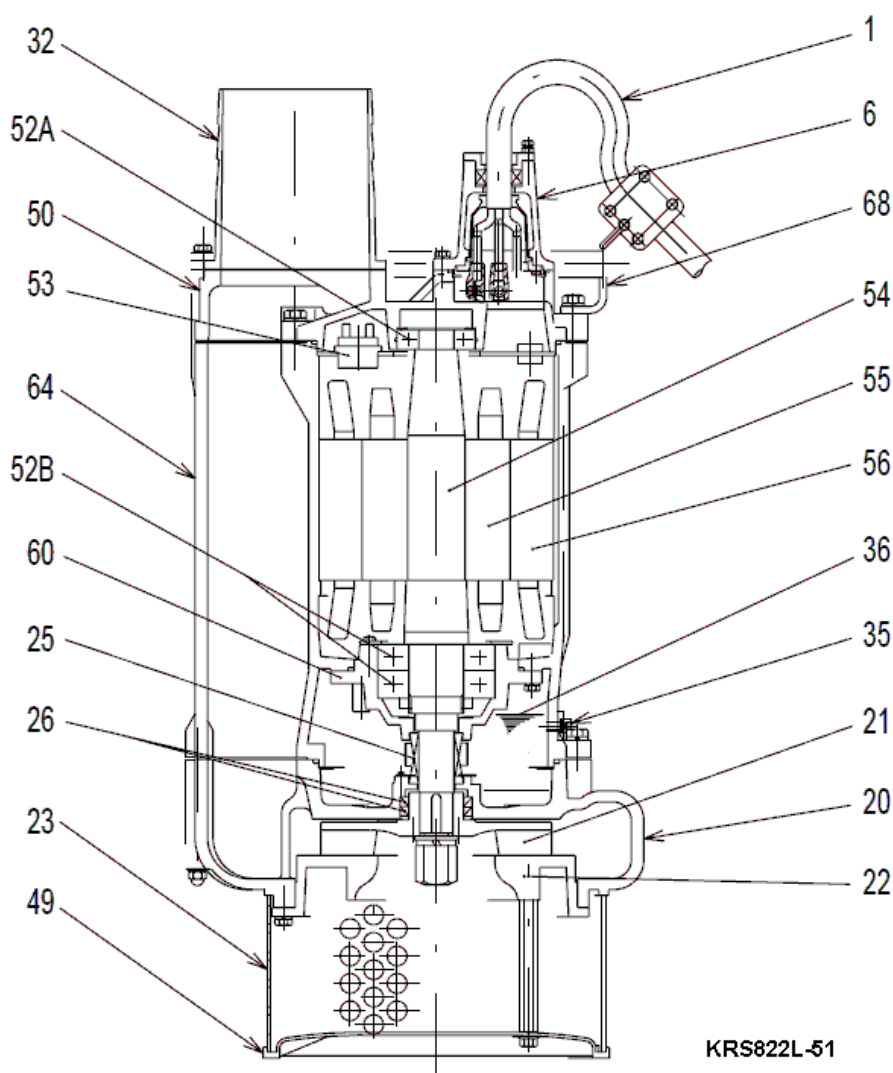

No.	Description	Remark	No.	Description	Remark
1	Cable	20m NSSHÖU	54	Shaft	SUS420J2 (EN-X30Cr13)
6	Stuffing box	FC200 (EN-GJL-200)	55	Rotor	.
20	Pump casing	FC200 (EN-GJL-200)	56	Stator	.
21	Impeller	FCD700 (EN-GJS-700-2)	60	Bearing Housing	FC200 (EN-GJL-200)
22	Suction cover	FC200 (EN-GJL-200)	64	Motor Frame	FC200 (EN-GJL-200)
23	Strainer	Steel plate	68	Handle	electroplated steel pipe
25	Mechanical seal	H-45X			
26	Oil seal	TC709212			
32	Discharge coupling	FC200 (EN-GJL-200)			
35	Oil screw	SUS304 (EN-X5CrNi18-10)			
36	Lubricant	Turbine oil (ISO VG32)			
49	Bottom Plate	Steel plate SPCC			
50	Main cover	FC200 (EN-GJL-200)			
52A	Upper bearing	6309ZZC3			
52B	Lower bearing	6314ZZC3			
53	Motor Protector 380/400/415V-50Hz	KA314-HRXL00 (H.C)			