

# Data sheet KRS815-51

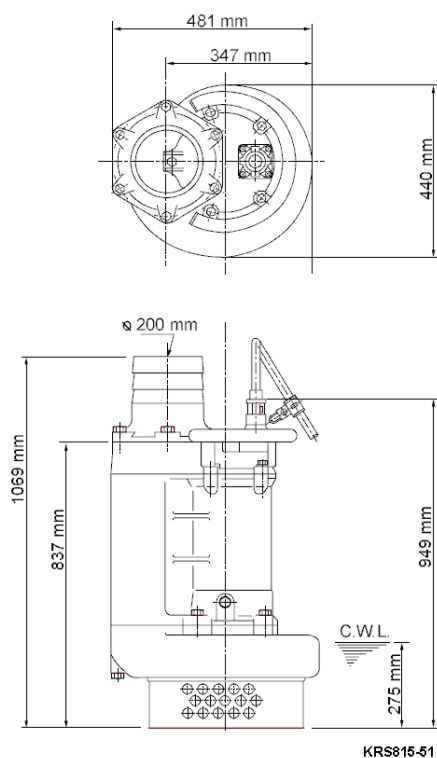

CWL: Continuous running water level

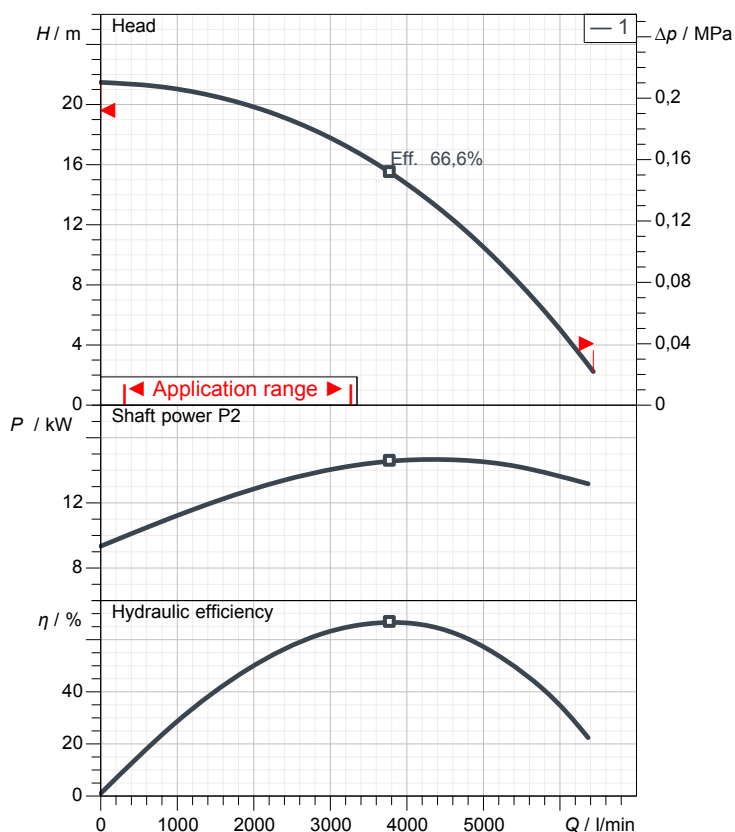

## Specification

Electric submersible pump KRS-series  
 Degree of protection IP 68  
 Pressure resistance max. 20 m  
 Type of impeller Semi-open  
 Max. solid handling 25 mm  
 Suitable for:  
 rain water, ground water, sand water

## Electric motor

Dry-type submersible induction motor  
 Insulation class F 4Poles 1450 1/min  
 Starting mode Direct starting  
 Rated voltage 400 V 50 Hz 3~  
 Power uptake 18,89 kW  
 Rated power 15,00 kW  
 Rated current 31,9 A  
 Start current 208,0 A

## Cable

20m NSSHÖU 4Cx6mm<sup>2</sup>

## Motor Protection

Circle thermal protector  
 (snap-action bi-metal device)

## Shaft seal

Double inside mechanical seal in oil bath  
 additional lubrication by oil lifting device  
 Primary seal  
 Silicon carbide on silicon carbide  
 Secondary seal  
 Silicon carbide on silicon carbide

## Bearings

Shielded ball bearings, maintenance-free

## Materials

Impeller	FCD700 (EN-GJS-700-2)
Pump casing	FC200 (EN-GJL-200)
Suction cover	FC200 (EN-GJL-200)
Motor Frame	FC200 (EN-GJL-200)
Shaft	SUS420J2 (EN-X30Cr13)

## Discharge size

8" (200mm) hose coupling

## Weight

240 kg (dry weight of the pump only without cable)

# Performance curve

## KRS815-51

Discharge port	8"
Head	21,5 m
Flow	6436,0 l/min
Rated power	15,00 kW
Power input	18,89 kW
Phases	3~
Voltages	400 V
Frequency	50 Hz
Rated current	31,9 A
Starting current	207,99 A
Number of poles	4
Speed	1450 1/min
Starting mode	Direct starting
Insulation class	F

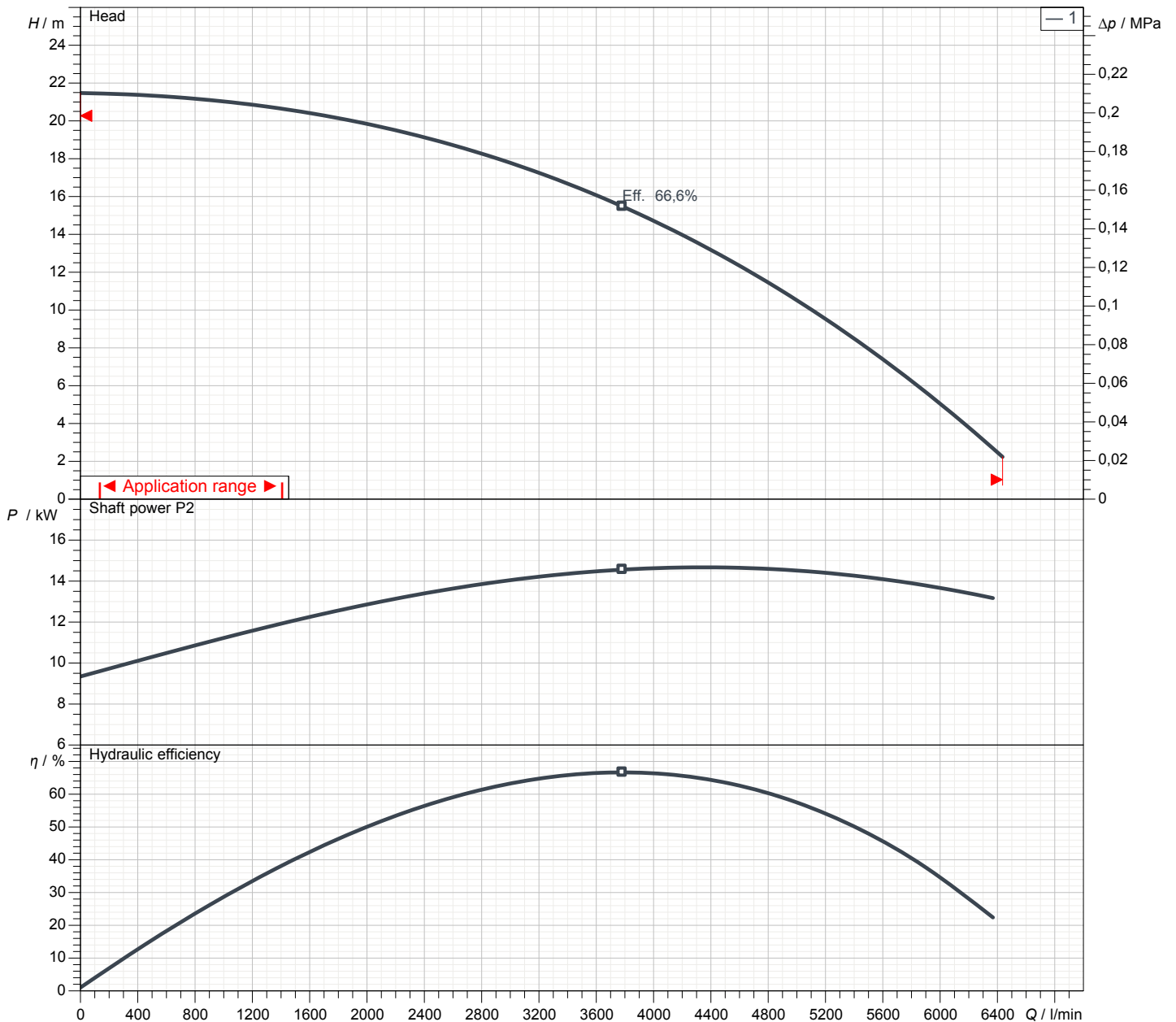

# Dimensions

## KRS815-51

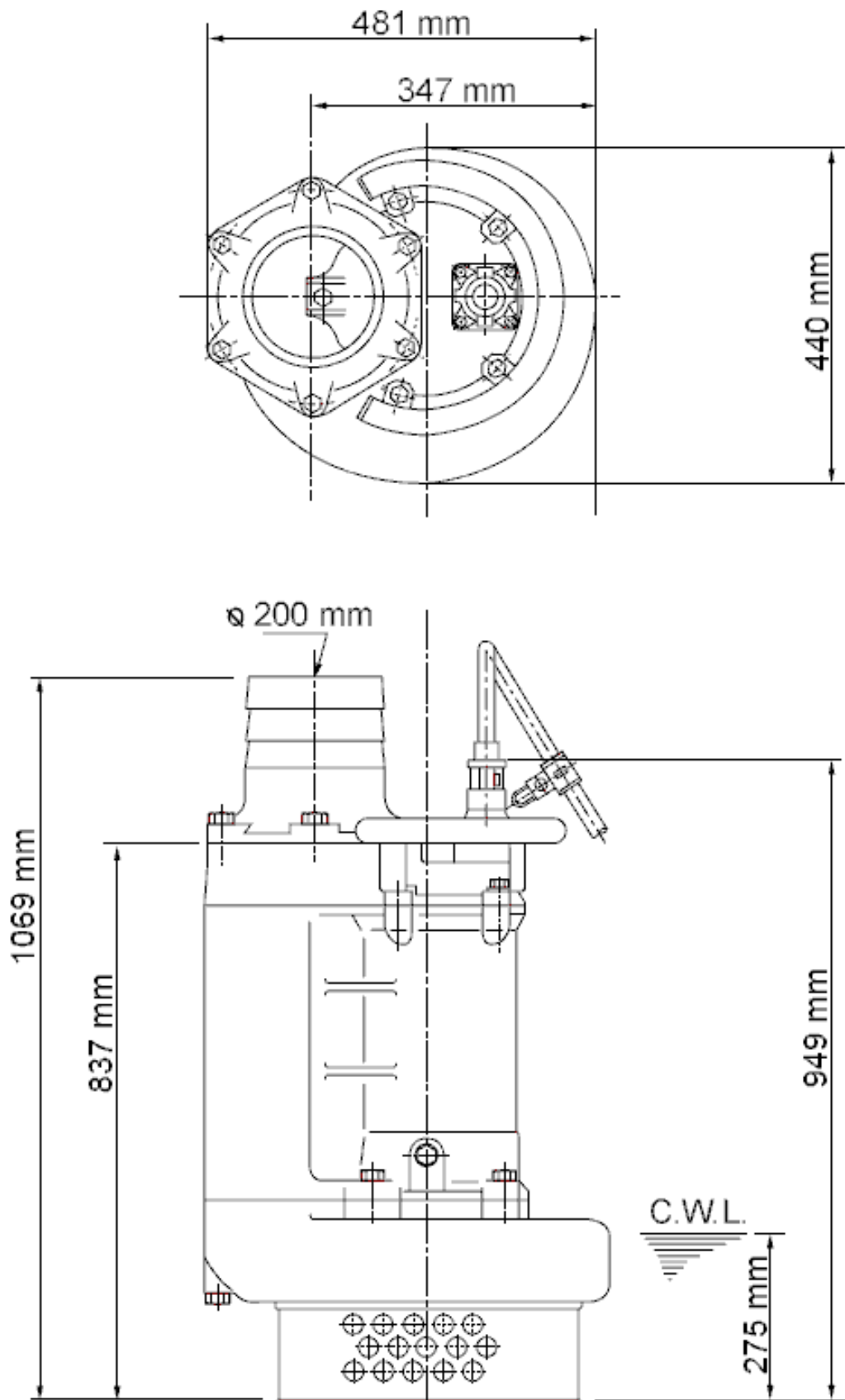

**KRS815-51**

**CWL: Continuous running water level**  
**LWL: Lowest running water level**

# Sectional drawing KRS815-51

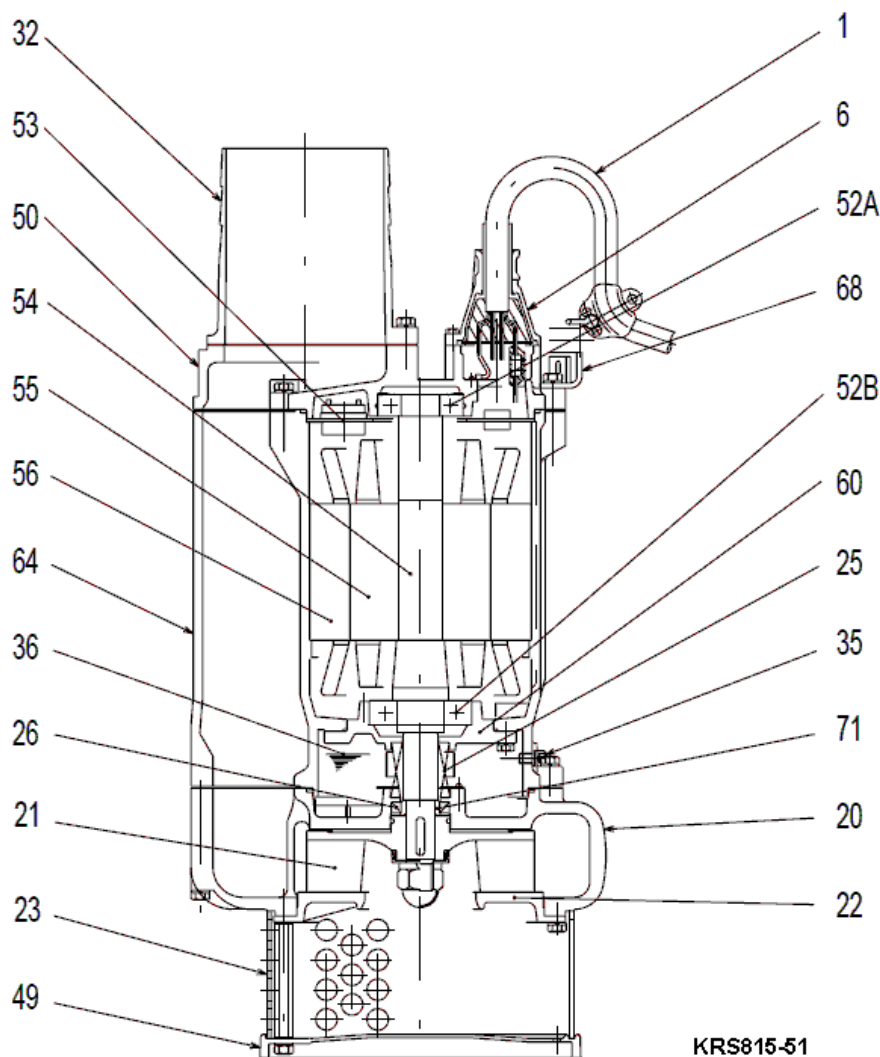

KRS815-51

No.	Description	Remark	No.	Description	Remark
1	Cable	20m NSSHÖU	54	Shaft	SUS420J2 (EN-X30Cr13)
6	Stuffing box	FC200 (EN-GJL-200)	55	Rotor	.
20	Pump casing	FC200 (EN-GJL-200)	56	Stator	.
21	Impeller	FCD700 (EN-GJS-700-2)	60	Bearing Housing	FC200 (EN-GJL-200)
22	Suction cover	FC200 (EN-GJL-200)	64	Motor Frame	FC200 (EN-GJL-200)
23	Strainer	Steel plate	68	Handle	electroplated steel pipe
25	Mechanical seal	H-40X	71	Shaft protection sleeve	SUS403 (EN-X6Cr13)
26	Oil seal	TC456812			
32	Discharge coupling	FC200 (EN-GJL-200)			
35	Oil screw	SUS304 (EN-X5CrNi18-10)			
36	Lubricant	Turbine oil (ISO VG32)			
49	Bottom Plate	Steel plate SPCC			
50	Main cover	FC200 (EN-GJL-200)			
52A	Upper bearing	6309ZZC3			
52B	Lower bearing	6311ZZC3			
53	Motor Protector 380/400/415V-50Hz	KA314-HRXL00 (H.C)			