

Data sheet KRS-65.5

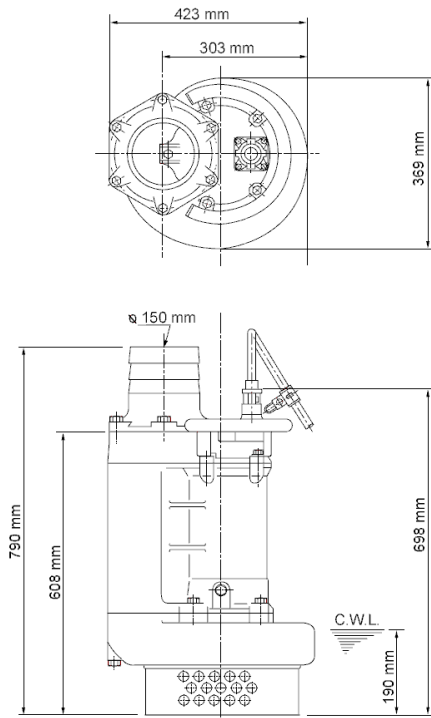

KRS-65.5

CWL: Continuous running water level

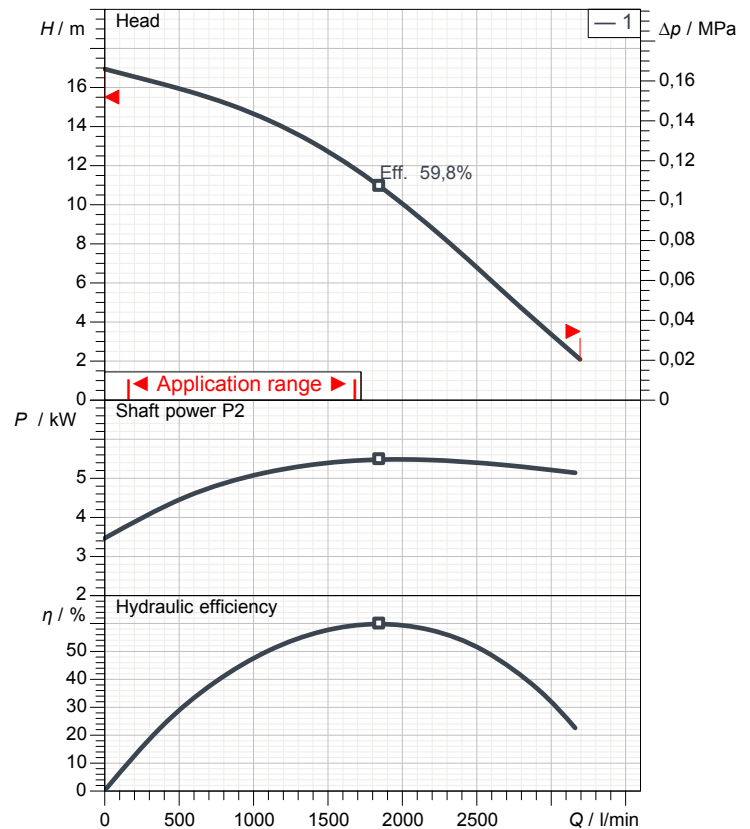

Specification

Electric submersible pump KRS-series
 Degree of protection IP 68
 Pressure resistance max. 15 m
 Type of impeller Semi-open
 Max. solid handling 20 mm
 Suitable for:
 rain water, ground water, sand water

Electric motor

Dry-type submersible induction motor
 Insulation class E 4 Poles 1435 1/min
 Starting mode Direct starting
 Rated voltage 400 V 50 Hz 3~
 Power uptake 6,91 kW
 Rated power 5,50 kW
 Rated current 12,1 A
 Start current 83,0 A

Cable

20m NSSHÖU 4Cx2,5mm²

Motor Protection

Circle thermal protector
 (snap-action bi-metal device)

Shaft seal

Double inside mechanical seal in oil bath
 additional lubrication by oil lifting device
 Primary seal
 Silicon carbide on silicon carbide
 Secondary seal
 Silicon carbide on silicon carbide

Bearings

Shielded ball bearings, maintenance-free

Materials

Impeller	FCD700 (EN-GJS-700-2)
Pump casing	FC200 (EN-GJL-200)
Suction cover	FC200 (EN-GJL-200)
Motor Frame	FC150 (EN-GJL-150)
Shaft	SUS420J2 (EN-X30Cr13)

Discharge size

6" (150mm) hose coupling

Weight

118 kg (dry weight of the pump only without cable)

Performance curve

KRS-65.5

Discharge port	6"
Head	16,9 m
Flow	3193,8 l/min
Rated power	5,50 kW
Power input	6,91 kW
Phases	3~
Voltages	400 V
Frequency	50 Hz
Rated current	12,1 A
Starting current	83,01 A
Number of poles	4
Speed	1435 1/min
Starting mode	Direct starting
Insulation class	E

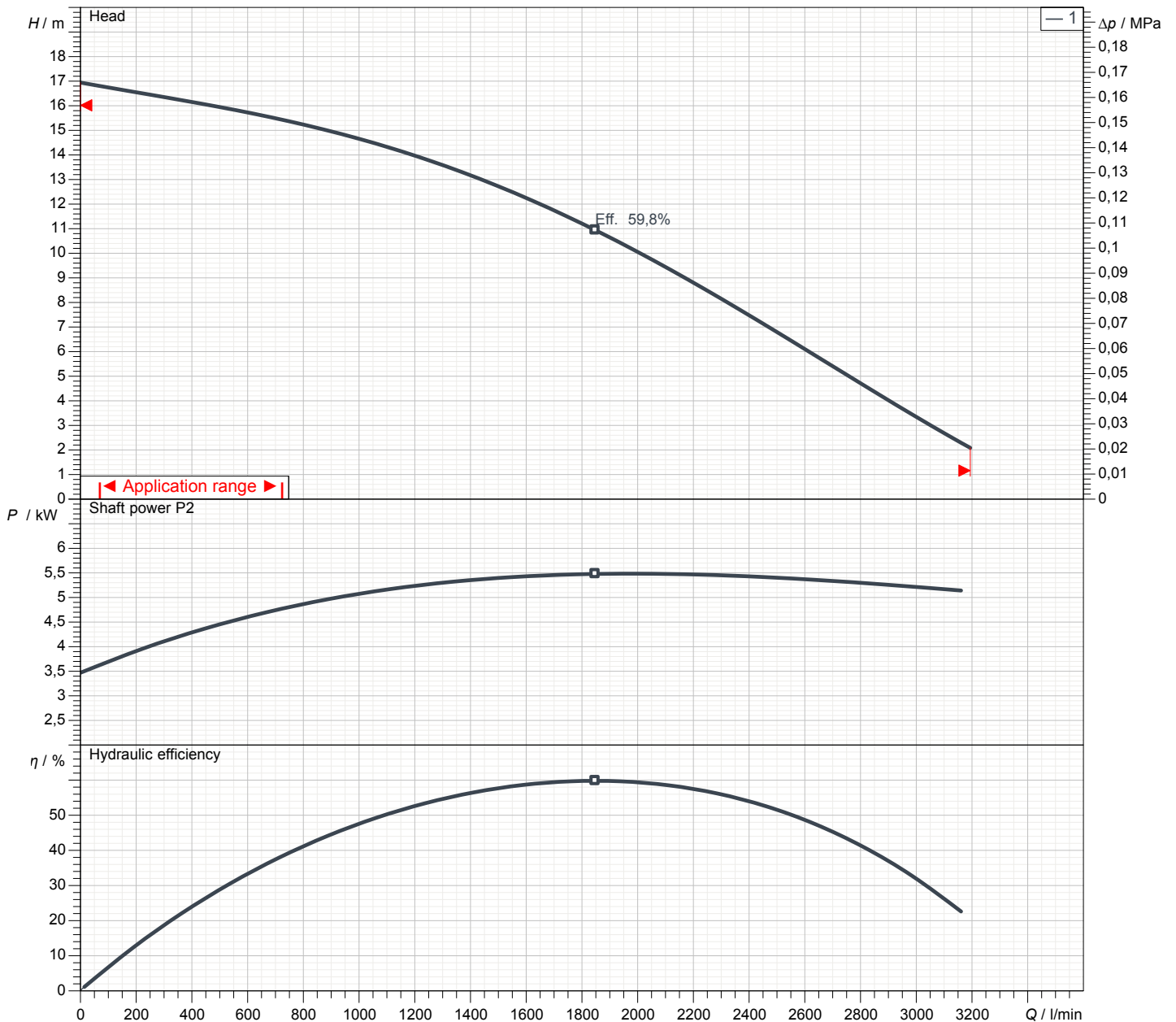

Dimensions

KRS-65.5

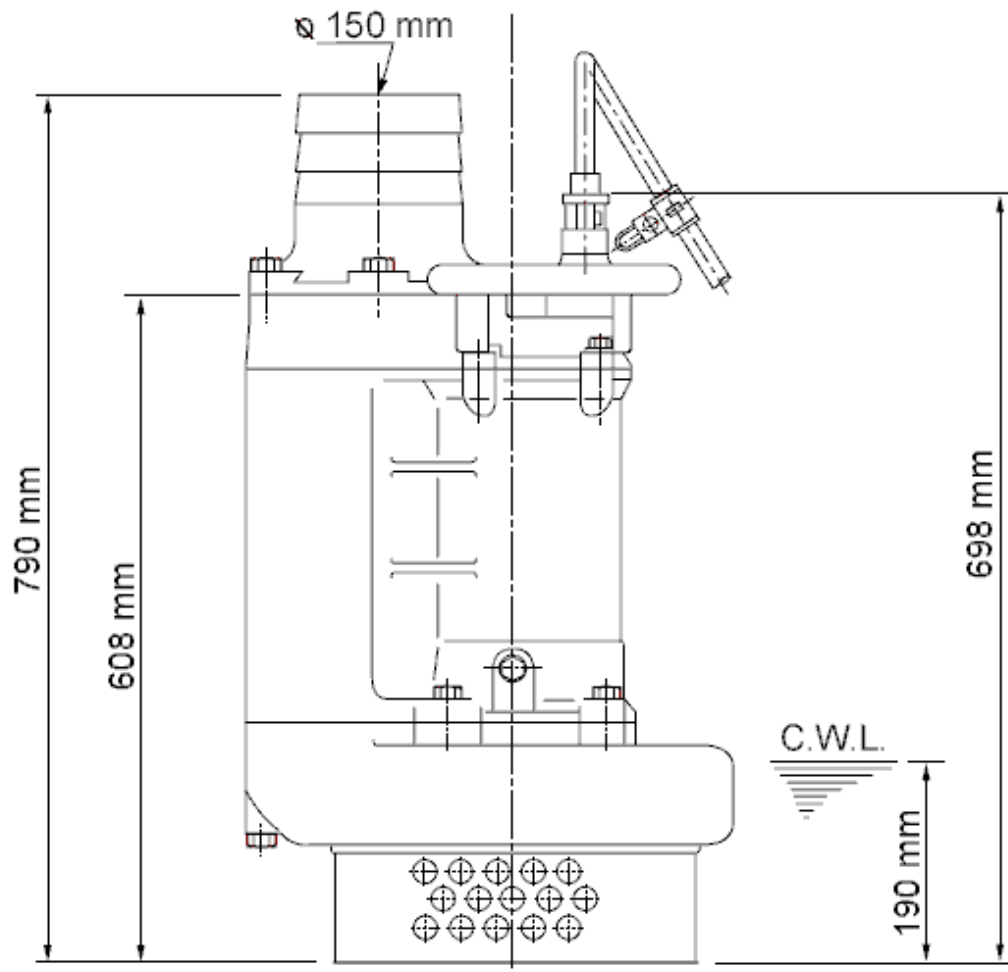
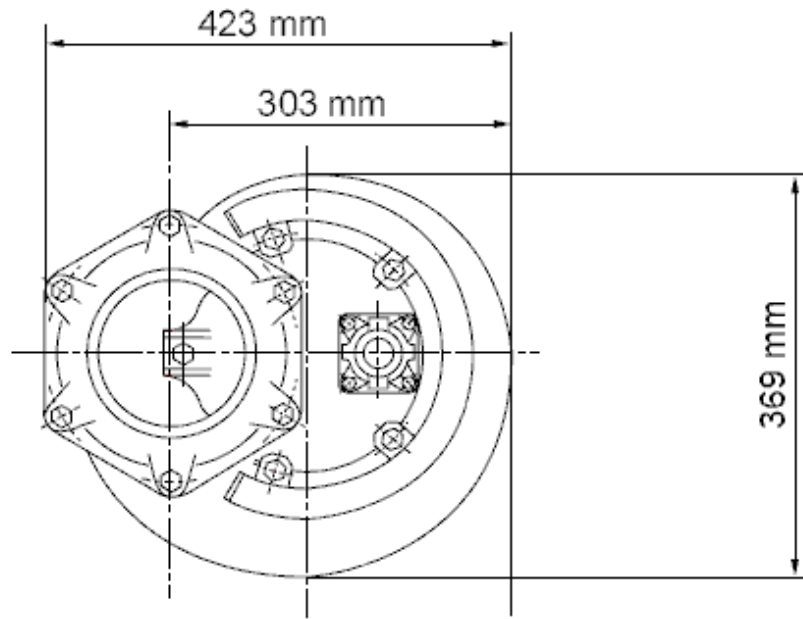

KRS-65.5

CWL: Continuous running water level
LWL: Lowest running water level

Sectional drawing KRS-65.5

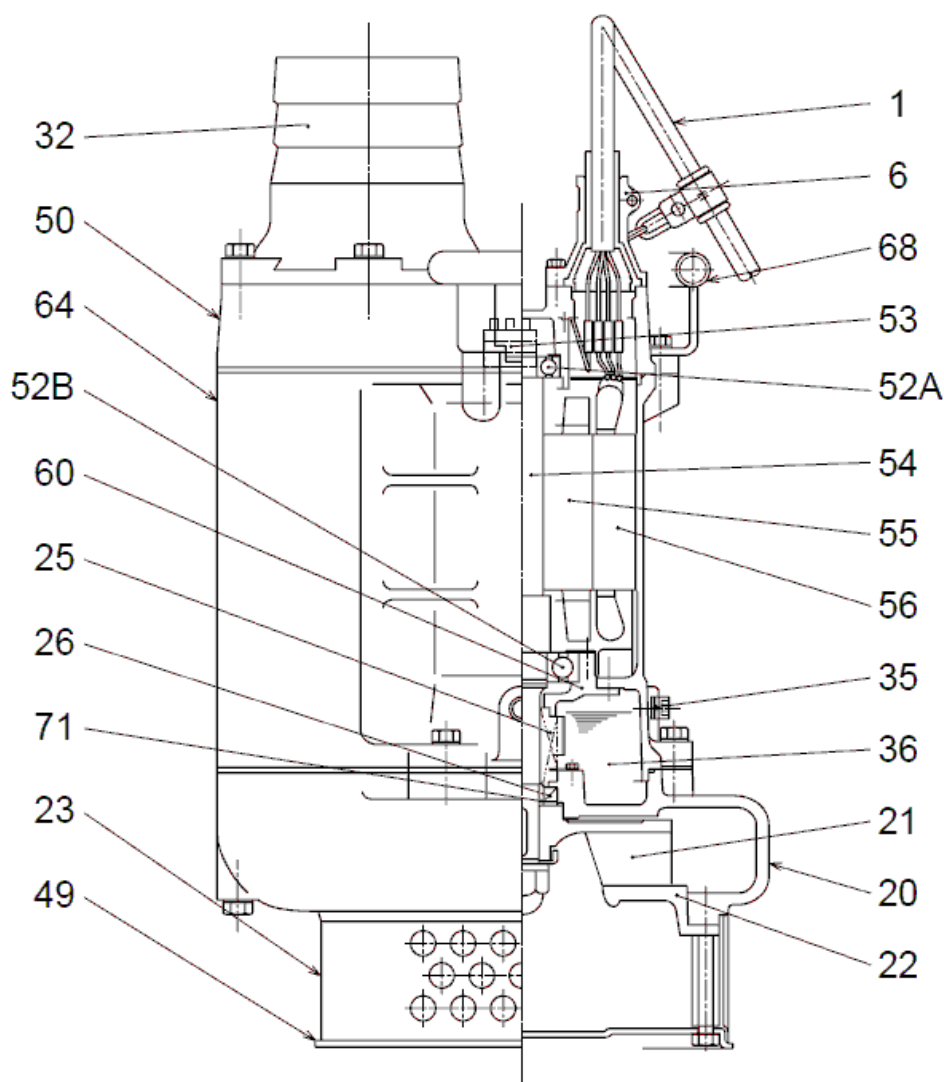

KRS-65.5

No.	Description	Remark	No.	Description	Remark
1	Cable	20m NSSHÖU	54	Shaft	SUS420J2 (EN-X30Cr13)
6	Stuffing box	FC200 (EN-GJL-200)	55	Rotor	.
20	Pump casing	FC200 (EN-GJL-200)	56	Stator	.
21	Impeller	FCD700 (EN-GJS-700-2)	60	Bearing Housing	FC150 (EN-GJL-150)
22	Suction cover	FC200 (EN-GJL-200)	64	Motor Frame	FC150 (EN-GJL-150)
23	Strainer	Steel plate	68	Handle	electroplated steel pipe
25	Mechanical seal	H-30T	71	Shaft protection sleeve	SUS403 (EN-X6Cr13)
26	Oil seal	.			
32	Discharge coupling	FC200 (EN-GJL-200)			
35	Oil screw	SUS304 (EN-X5CrNi18-10)			
36	Lubricant	Turbine oil (ISO VG32)			
49	Bottom Plate	Steel plate SPCC			
50	Main cover	FC150 (EN-GJL-150)			
52A	Upper bearing	.			
52B	Lower bearing	.			
53	Motor Protector 380/400/415V-50Hz	KA314-HRXL00 (H.C)			