

Data sheet 50TMA2.75S-53

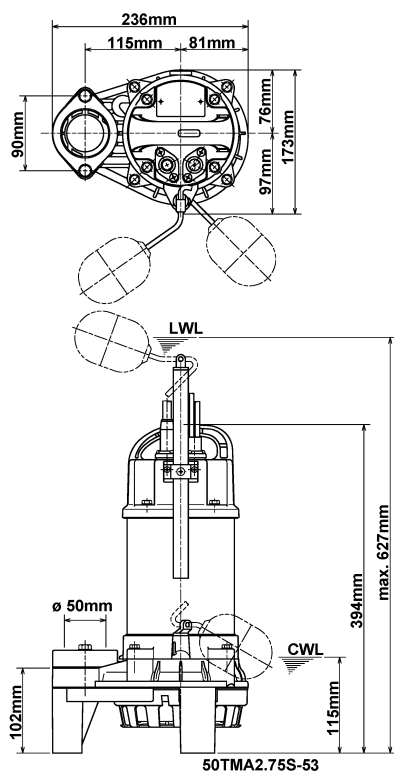

CWL: Continuous running water level
LWL: Lowest running water level

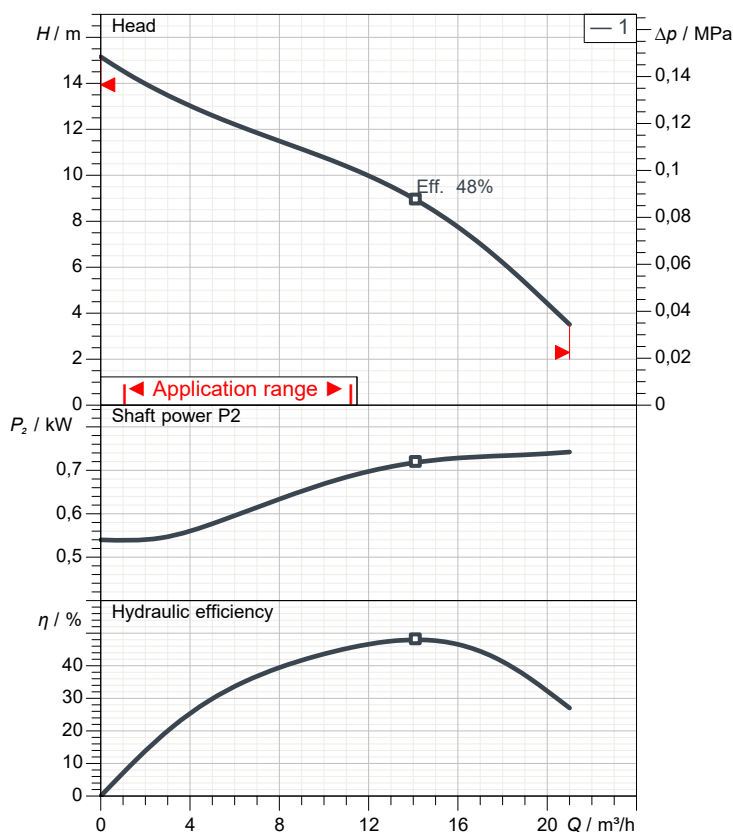

Specification

Electric submersible pump TM-series
Degree of protection IP 68
Pressure resistance max. 10 m
Type of impeller Vortex impeller
Free passage 10 mm
Suitable for:
sea water, salt water

Electric motor

Dry-type submersible induction motor
Insulation class E 2Poles 2.804 1/min
Starting mode
Rated voltage 230 V 50 Hz 1~
Power uptake 1,11 kW
Rated power 0,75 kW
Rated current 5,5 A
Start current 16,8 A

Cable

10m H07RN8-F 3Cx1mm²

Motor Protection

Circle thermal protector
(snap-action bi-metal device)

Shaft seal

Double inside mechanical seal in oil bath
additional lubrication by oil lifting device
Primary seal
Silicon carbide on ceramic
Secondary seal
Ceramic on carbon

Bearings

Shielded ball bearings, maintenance-free

Materials

Impeller	PPO-GF20
Motor Frame	Titanium
Shaft	Titanium

Discharge size

50mm screwed-in mating flange

Weight

8,3 kg (dry weight of the pump only without cable)

Performance curve

50TMA2.75S-53

Discharge port	2"
Head	15,2 m
Flow	21,0 m ³ /h
Rated power	0,75 kW
Power input	1,11 kW
Phases	1~
Voltages	230 V
Frequency	50 Hz
Rated current	5,5 A
Starting current	16,83 A
Number of poles	2
Speed	2.804 1/min
Starting mode	
Insulation class	E

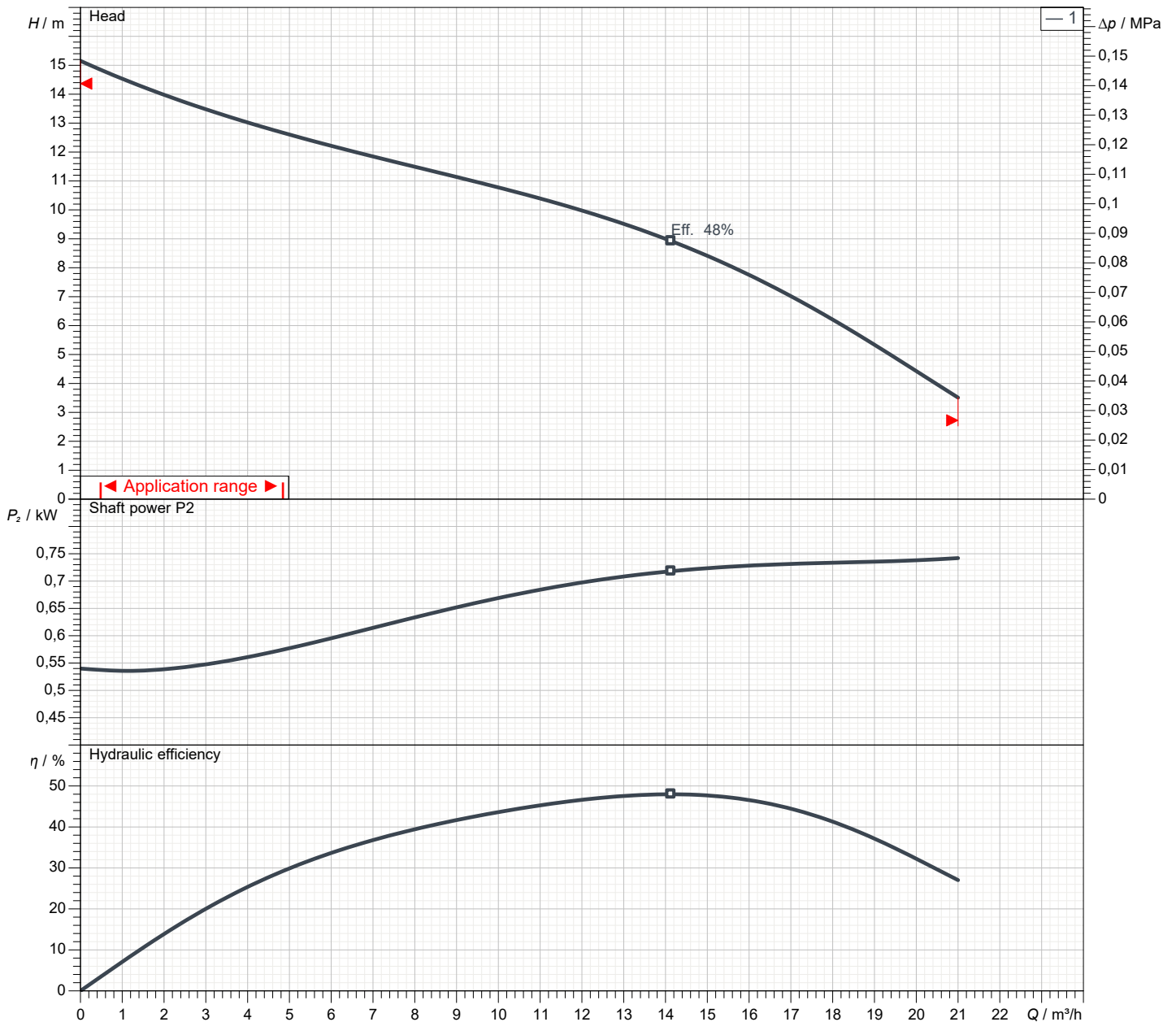

Dimensions

50TMA2.75S-53

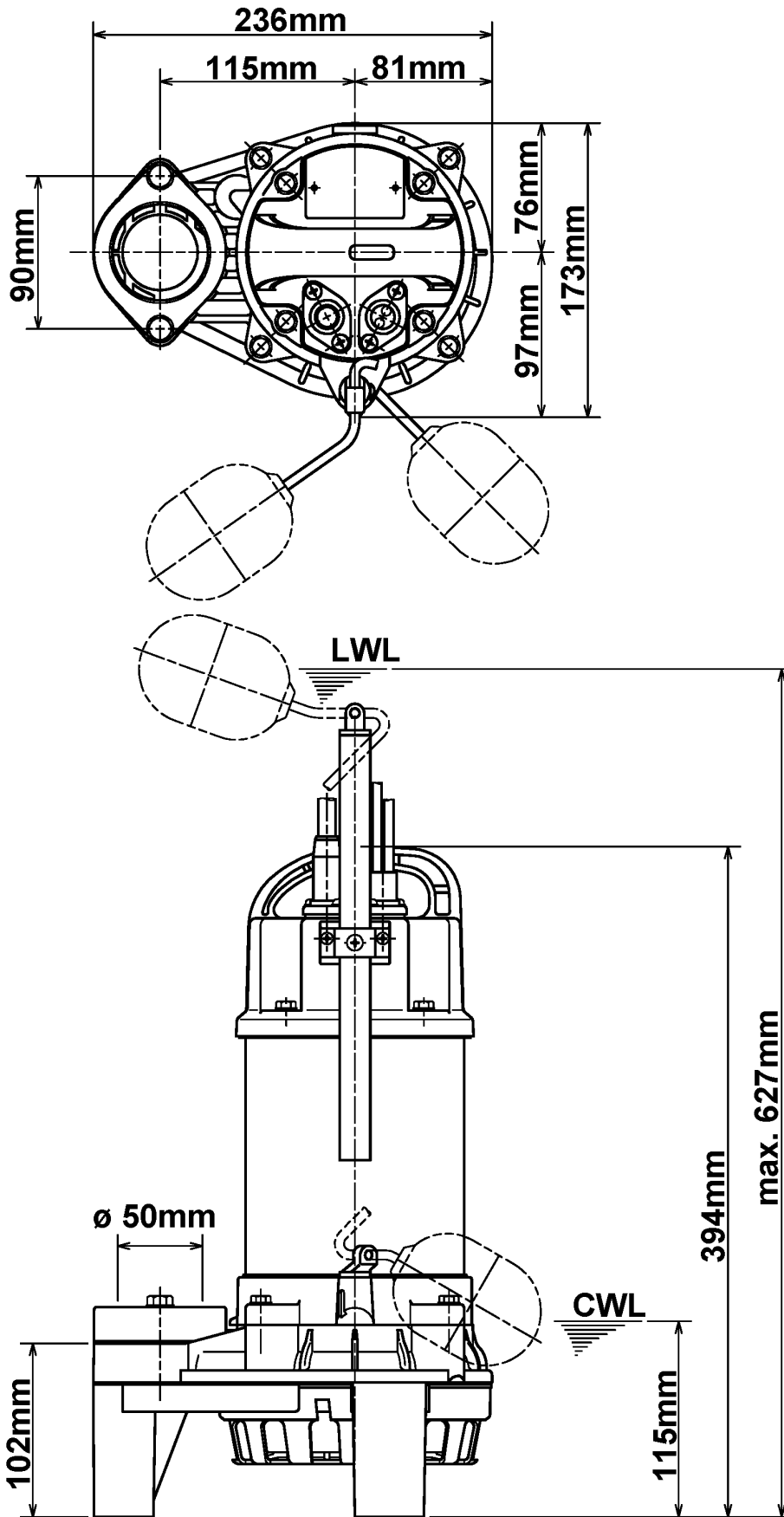

50TMA2.75S-53

CWL: Continuous running water level
LWL: Lowest running water level

Sectional drawing 50TMA2.75S-53

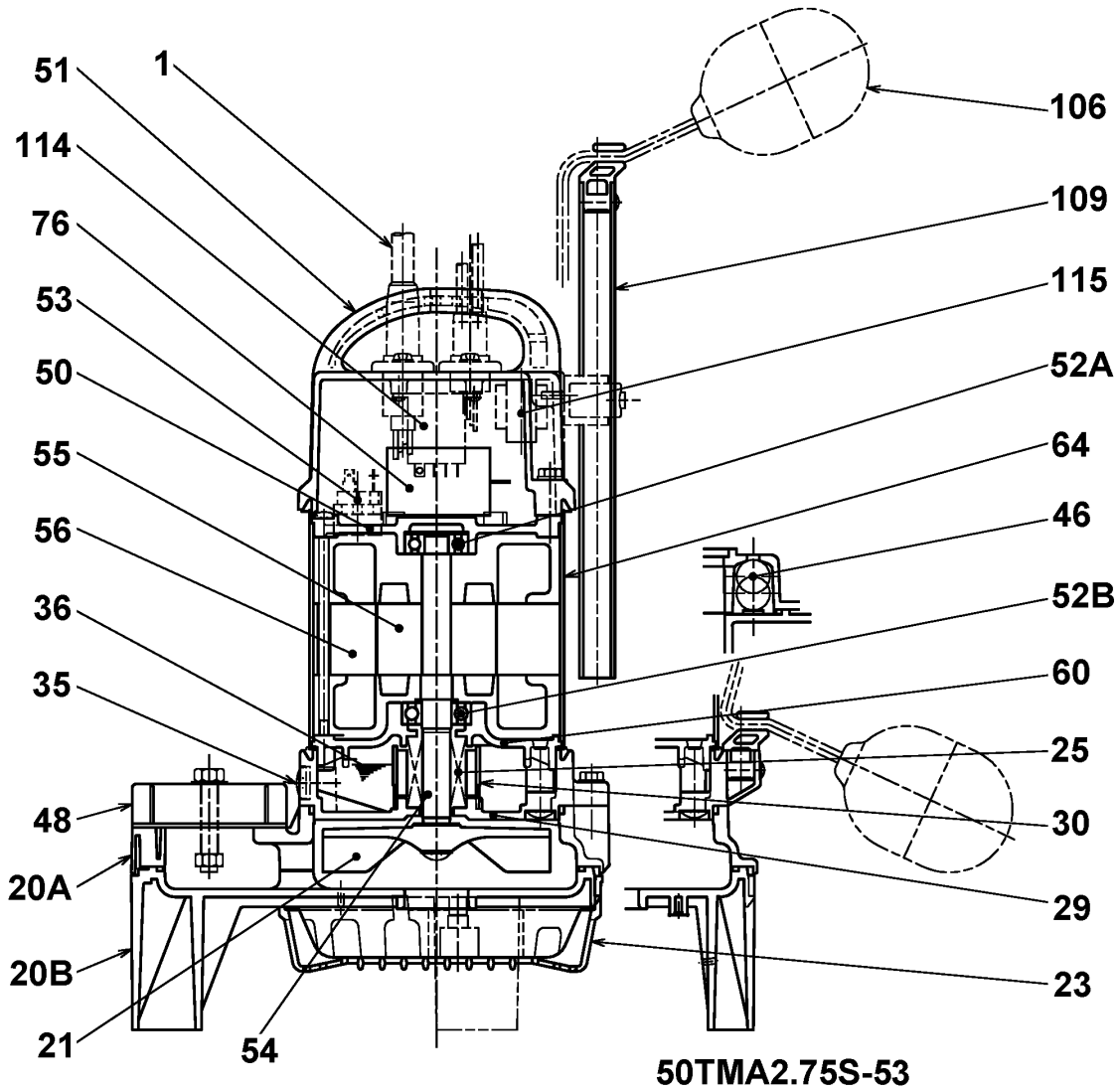

No.	Description	Remark	No.	Description	Remark
1	Cable	H07RN-F	53	Motor Protector 380/400/415V-50Hz,KA314-HRXL00 (H.C)	
20A	Upper Pump casing	ABS-GF20	54	Shaft	Titanium
20B	Lower Pump casing	ABS	55	Rotor	.
21	Impeller	PPO-GF20	56	Stator	.
23	Strainer	ABS	60	Bearing Housing	ADC12 Aluminium die casting
25	Mechanical seal	W-14HL	64	Motor Frame	Titanium
29	Oil casing	PPS-GF40	76	Condenser	.
30	Oil distributor	Plastic	106	Float switch (2x)	ABS
35	Oil screw	Titanium	109	Support	PVC
36	Lubricant	white oil (ISO VG32)	114	Relais	.
46	Air vent valve	Glass bead	115	Transformator	.
48	Screwed Flange	Polycarbonate			
50	Motor cover	ADC12 Aluminium die casting			
51	Main cover	PPO+PPS -GF40			
52A	Upper bearing	6201ZZC3			
52B	Lower bearing	6302ZZC3			