

Data sheet 100UZ47.5-54

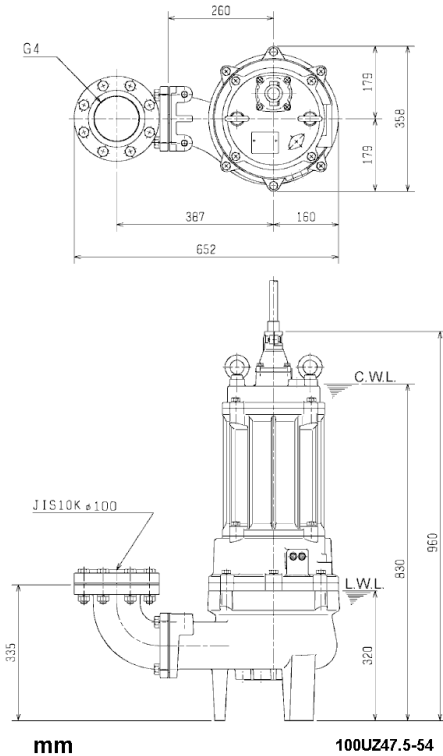

CWL: Continuous running water level
LWL: Lowest running water level

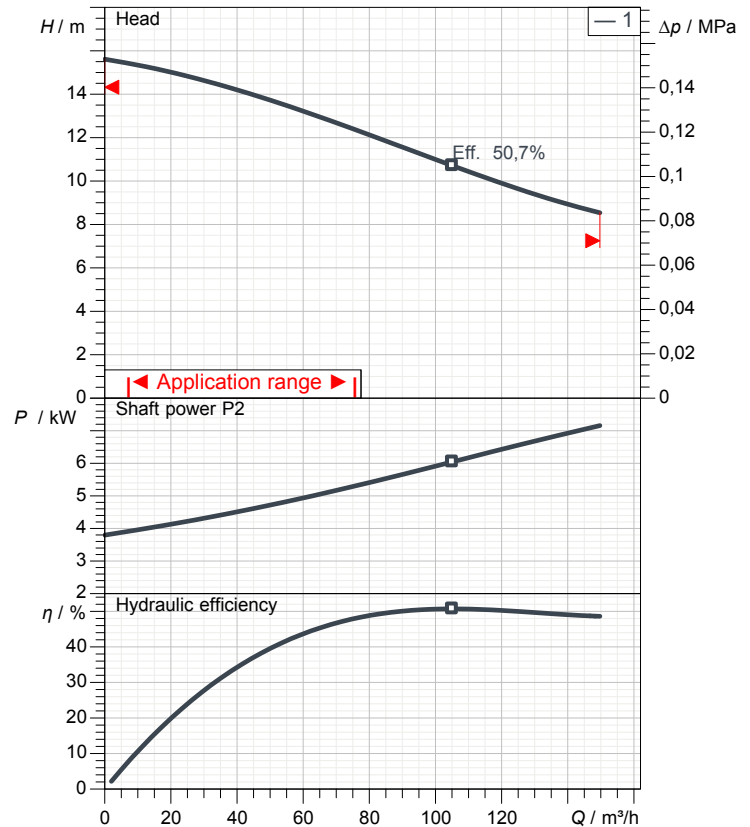

Specification

Electric submersible pump UZ-series
Degree of protection IP 68
Pressure resistance max. 15 m
Type of impeller Vortex impeller
Free passage 100 mm
Suitable for:
waste water and liquid carrying

Electric motor

Dry-type submersible induction motor
Insulation class F 4 Poles 1455 1/min
Starting mode Direct starting
Rated voltage 400 V 50 Hz 3~
Power uptake 9,15 kW
Rated power 7,50 kW
Rated current 15,9 A
Start current 89,0 A

Cable

10m H07RN-F 4Cx4mm²

Motor Protection

Circle thermal protector
(snap-action bi-metal device)

Shaft seal

Double inside mechanical seal in oil bath
additional lubrication by oil lifting device
Primary seal
Silicon carbide on silicon carbide
Secondary seal
Silicon carbide on silicon carbide

Bearings

Shielded ball bearings, maintenance-free

Materials

Impeller	FC200 (EN-GJL-200)
Pump casing	FC200 (EN-GJL-200)
Motor Frame	FC200 (EN-GJL-200)
Shaft	SUS420J2 (EN-X30Cr13)

Discharge size

4" (100mm) special screwed-in mating flange
guide rail fitting optional

Weight

158 kg (dry weight of the pump only without cable)

Performance curve

100UZ47.5-54

Discharge port	4"
Head	15,6 m
Flow	149,7 m ³ /h
Rated power	7,50 kW
Power input	9,15 kW
Phases	3~
Voltages	400 V
Frequency	50 Hz
Rated current	15,9 A
Starting current	89,04 A
Number of poles	4
Speed	1455 1/min
Starting mode	Direct starting
Insulation class	F

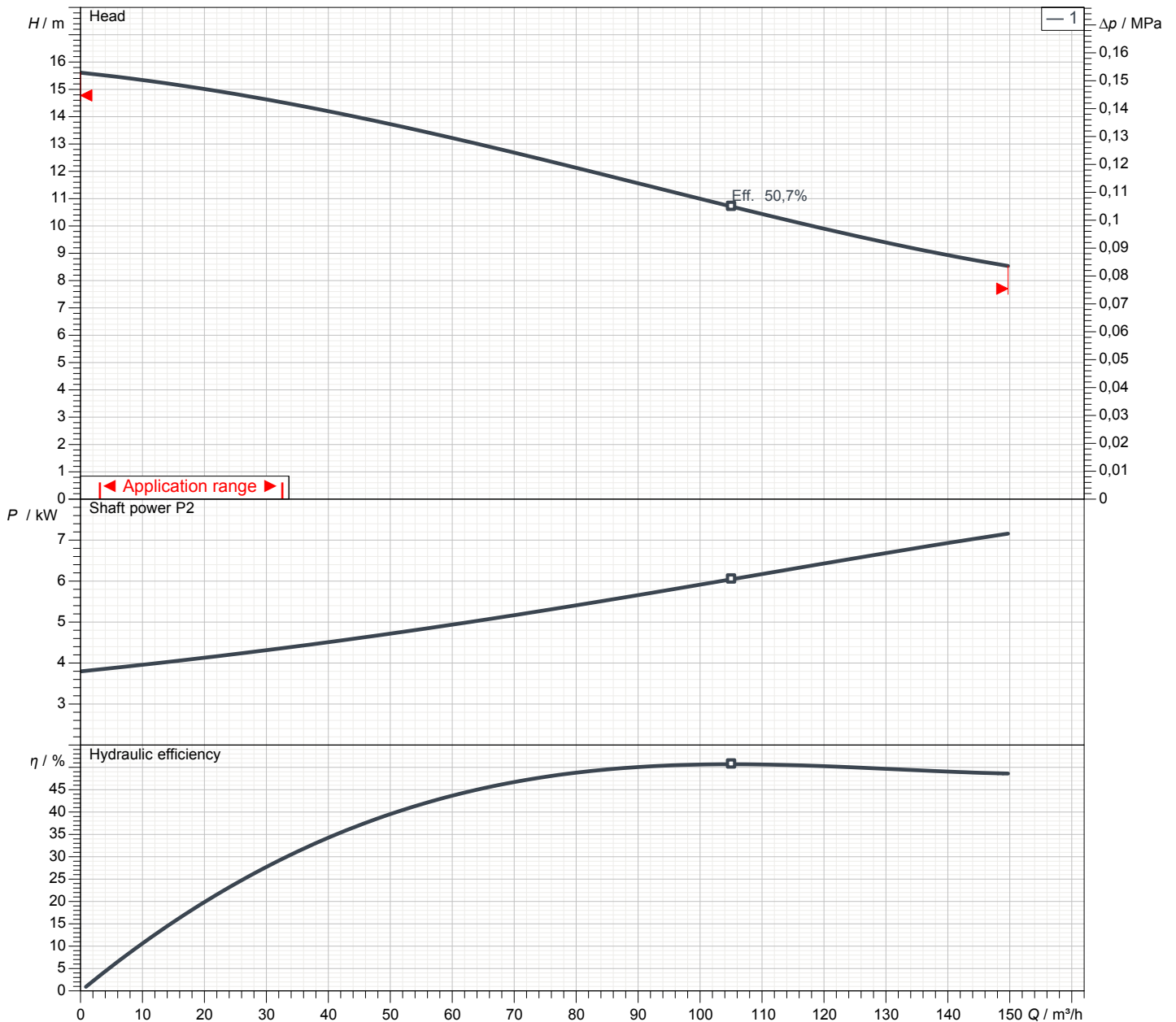

Dimensions

100UZ47.5-54

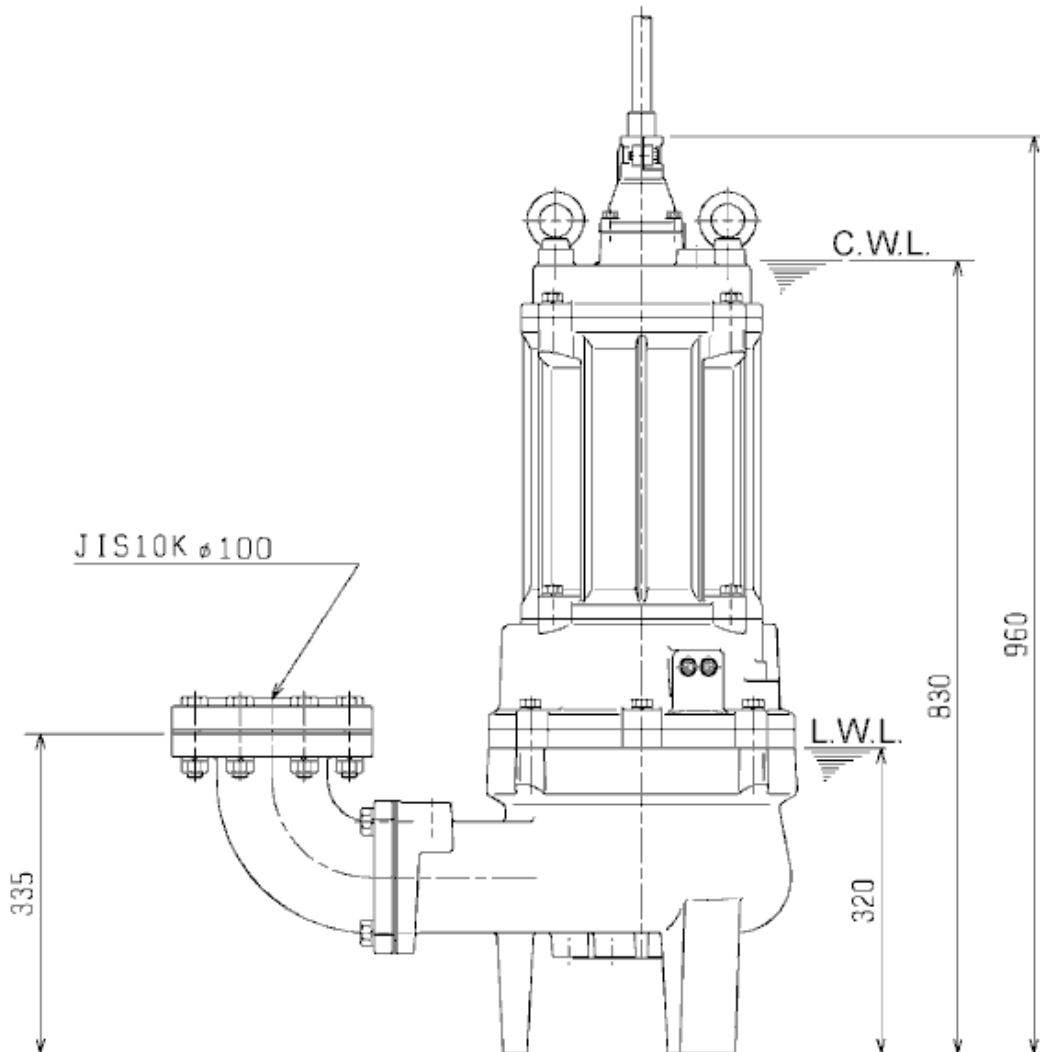
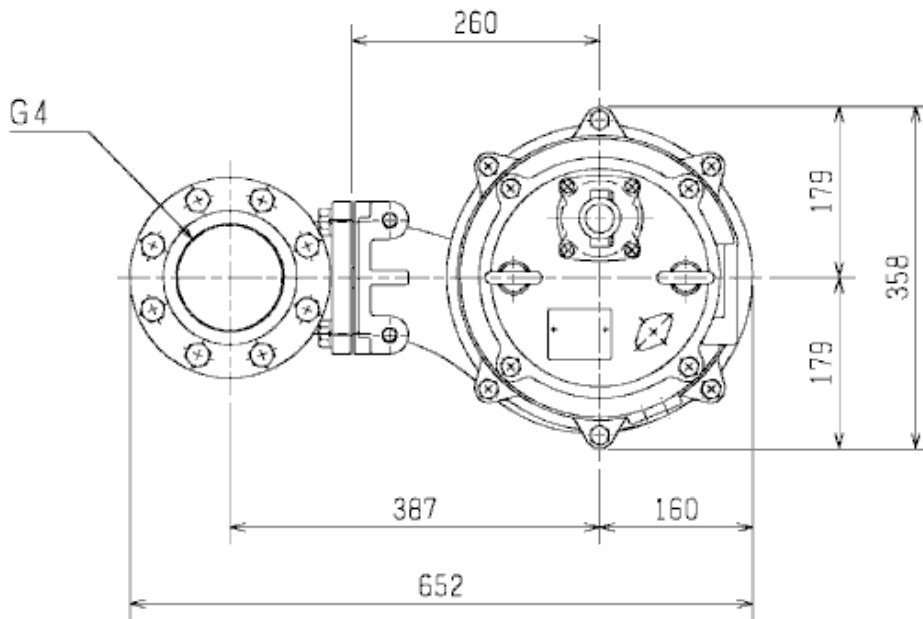

mm

100UZ47.5-54

CWL: Continuous running water level
LWL: Lowest running water level

Sectional drawing 100UZ47.5-54

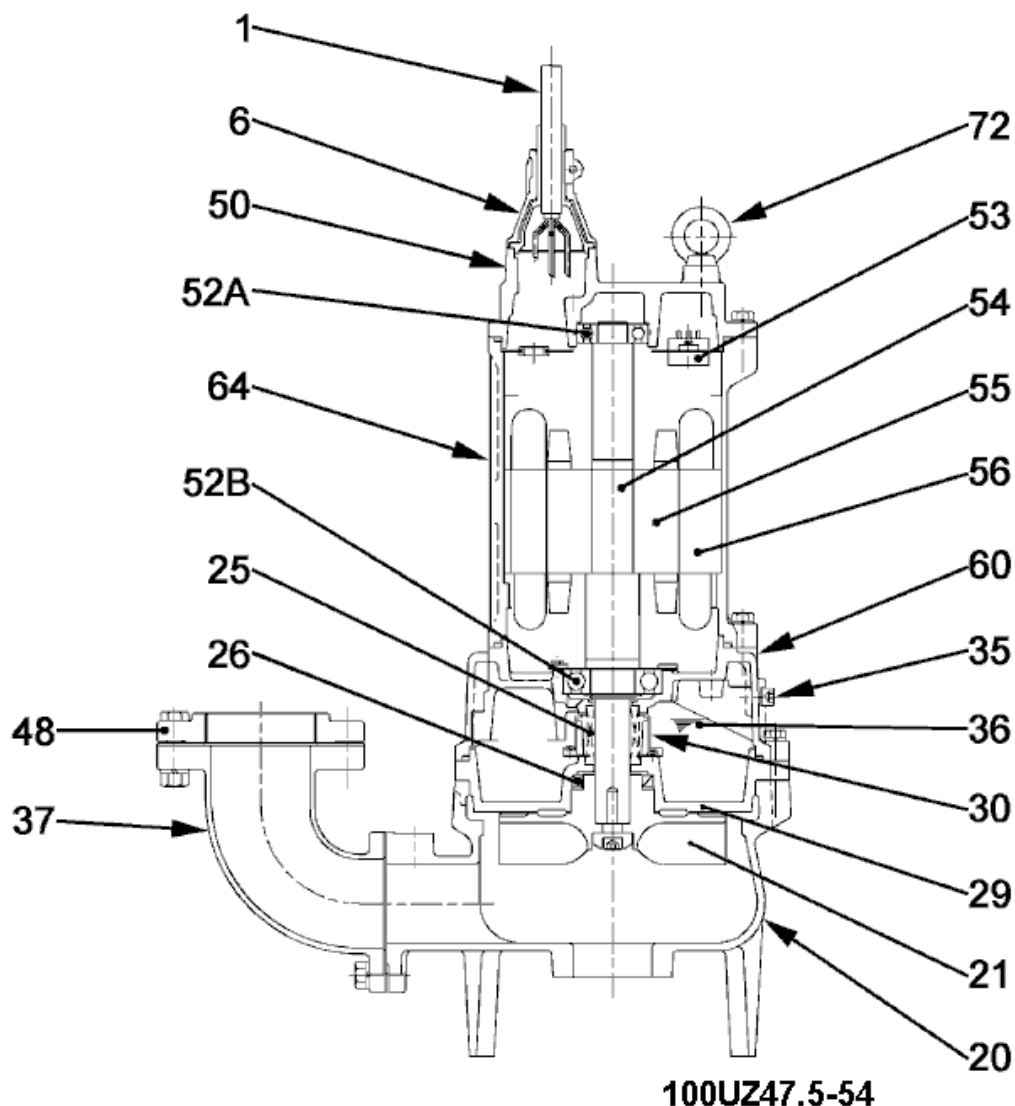

No.	Description	Remark	No.	Description	Remark
1	Cable	H07RN-F	54	Shaft	SUS420J2 (EN-X30Cr13)
6	Stuffing box	FC200 (EN-GJL-200)	55	Rotor	.
20	Pump casing	FC200 (EN-GJL-200)	56	Stator	.
21	Impeller	FC200 (EN-GJL-200)	60	Bearing Housing	FC200 (EN-GJL-200)
25	Mechanical seal	H-35A	64	Motor Frame	FC200 (EN-GJL-200)
26	Oil seal	TC608212	72	Eye screw (2x)	SS400 (DIN 1.0040)
29	Oil casing	FC200 (EN-GJL-200)			
30	Oil distributor	Plastic			
35	Oil screw (2x)	SUS304 (EN-X5CrNi18-10)			
36	Lubricant	Turbine oil (ISO VG32)			
37	Discharge bend	FC200 (EN-GJL-200)			
48	Screwed Flange	FC200 (EN-GJL-200)			
50	Motor cover	FC200 (EN-GJL-200)			
52A	Upper bearing	6306ZZC3			
52B	Lower bearing	6309ZZC3			
53	Motor Protector 380/400/415V-50Hz	z.KA314-HRXL00 (H.C)			