

Data sheet 100UZ43.7-51

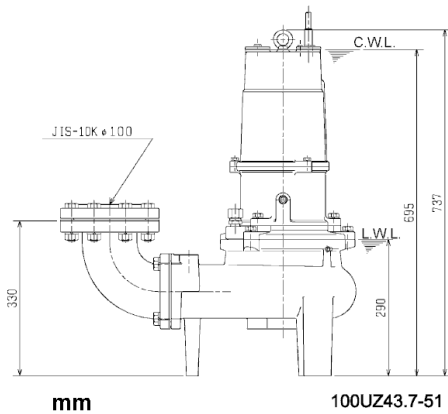

CWL: Continuous running water level
LWL: Lowest running water level

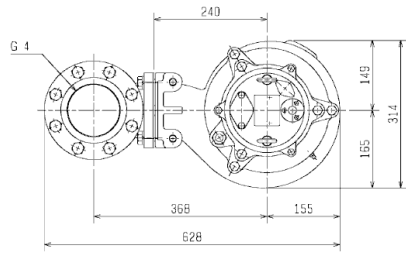
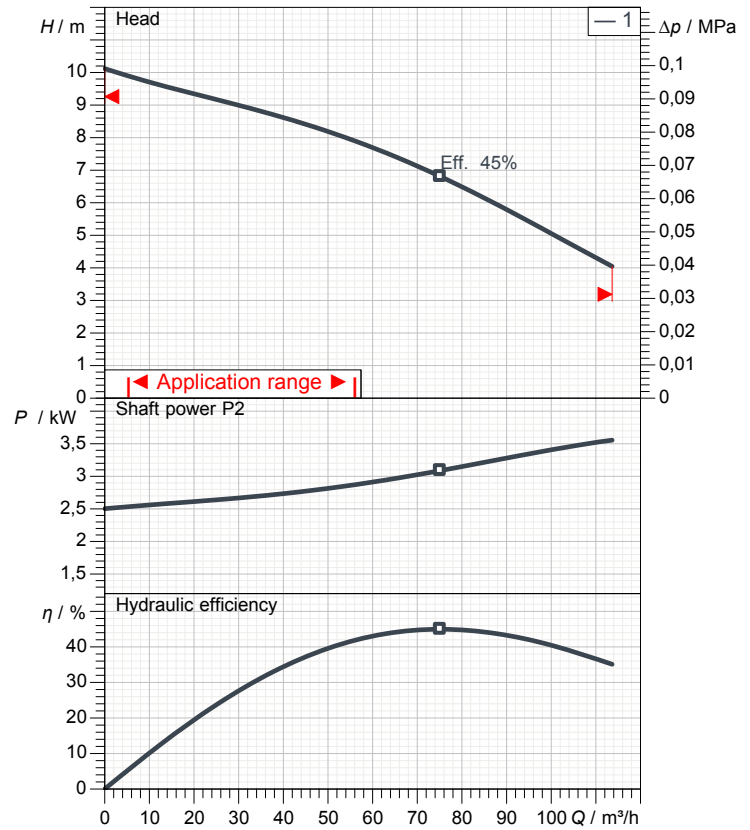

Specification

Electric submersible pump UZ-series
Degree of protection IP 68
Pressure resistance max. 15 m
Type of impeller Vortex impeller
Free passage 100 mm
Suitable for:
waste water and liquid carrying

Electric motor

Dry-type submersible induction motor
Insulation class E 4 Poles 1410 1/min
Starting mode Direct starting
Rated voltage 400 V 50 Hz 3~
Power uptake 4,57 kW
Rated power 3,70 kW
Rated current 7,9 A
Start current 62,4 A

Cable

10m H07RN-F 4Cx1,5mm²

Motor Protection

Circle thermal protector
(snap-action bi-metal device)

Shaft seal

Double inside mechanical seal in oil bath
additional lubrication by oil lifting device
Primary seal
Silicon carbide on silicon carbide
Secondary seal
Silicon carbide on silicon carbide

Bearings

Shielded ball bearings, maintenance-free

Materials

Impeller	FC200 (EN-GJL-200)
Pump casing	FC200 (EN-GJL-200)
Motor Frame	FC150 (EN-GJL-150)
Shaft	SUS420J2 (EN-X30Cr13)

Discharge size

4" (100mm) special screwed-in mating flange
guide rail fitting optional

Weight

79 kg (dry weight of the pump only without cable)

Performance curve

100UZ43.7-51

Discharge port	4"
Head	10,1 m
Flow	113,7 m ³ /h
Rated power	3,70 kW
Power input	4,57 kW
Phases	3~
Voltages	400 V
Frequency	50 Hz
Rated current	7,9 A
Starting current	62,41 A
Number of poles	4
Speed	1410 1/min
Starting mode	Direct starting
Insulation class	E

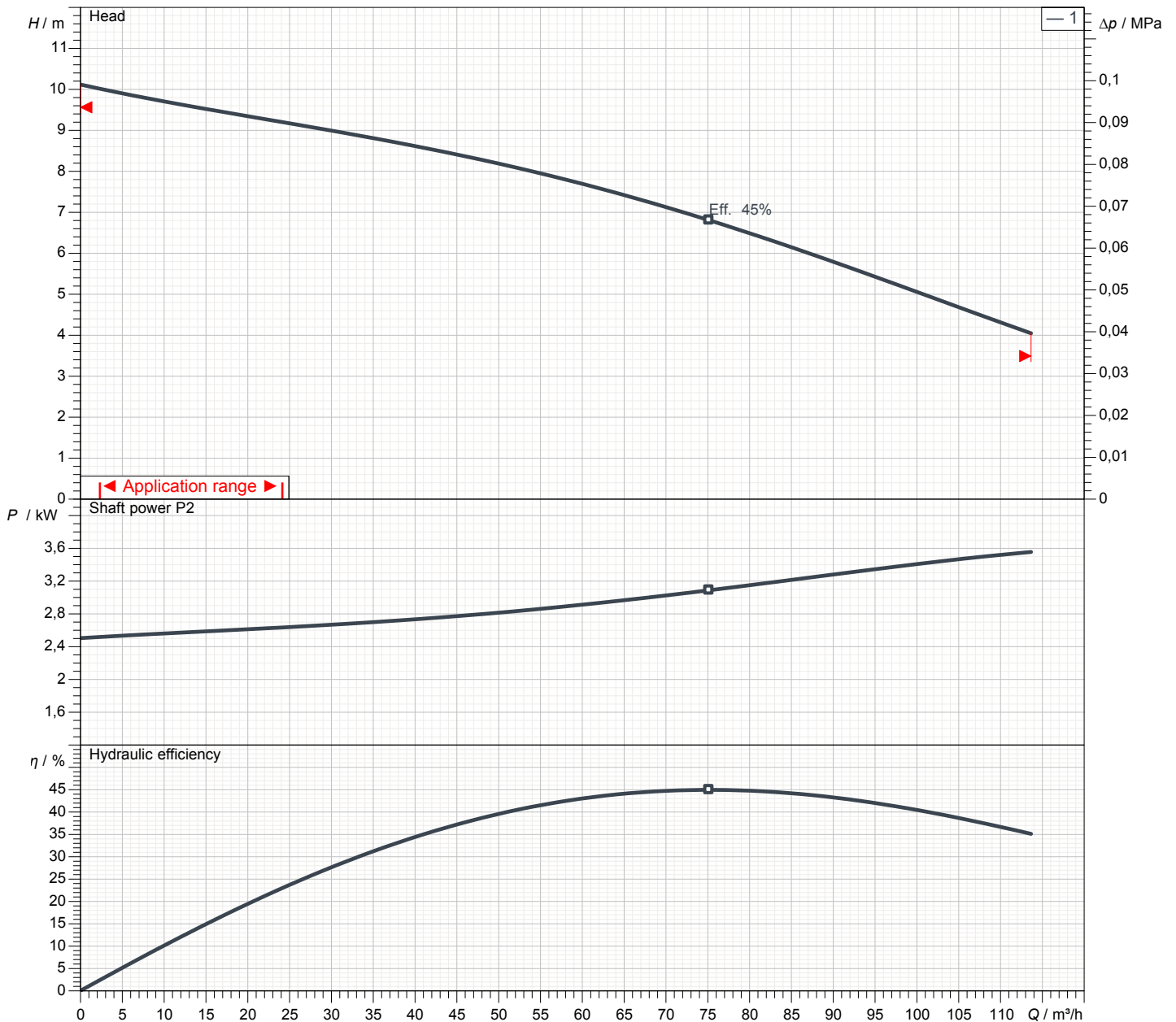

Dimensions

100UZ43.7-51

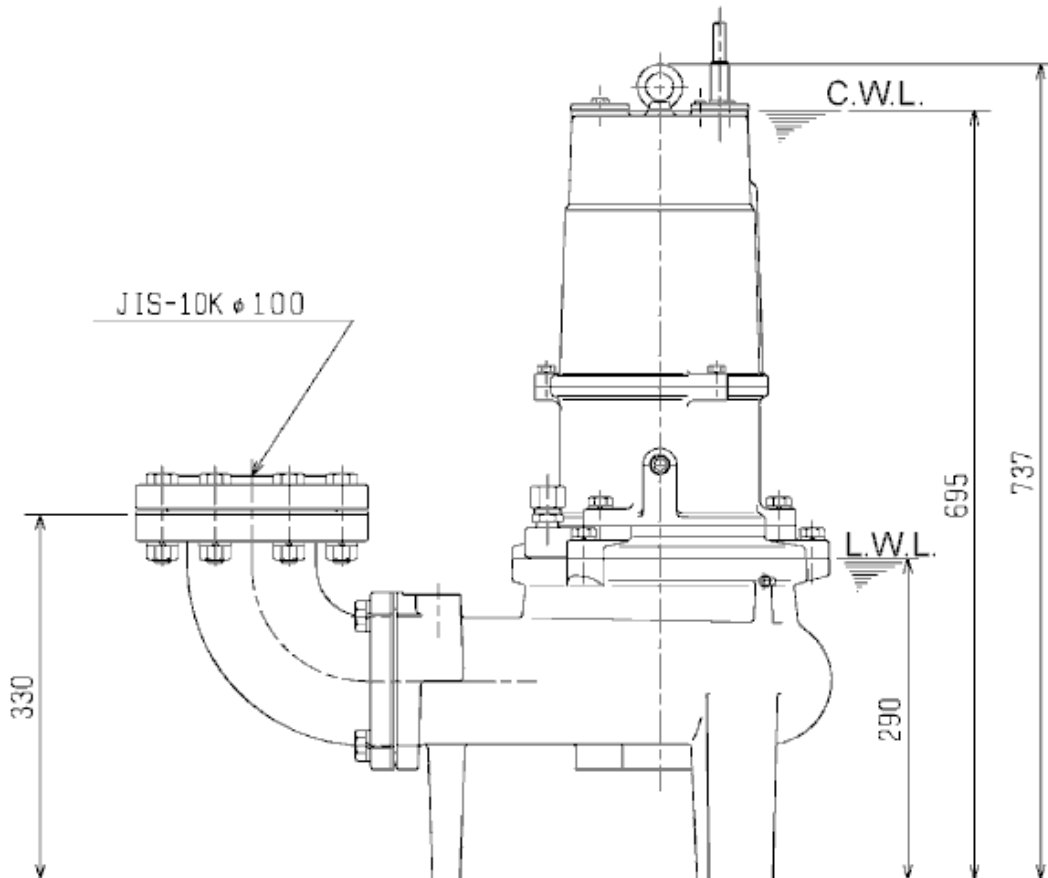
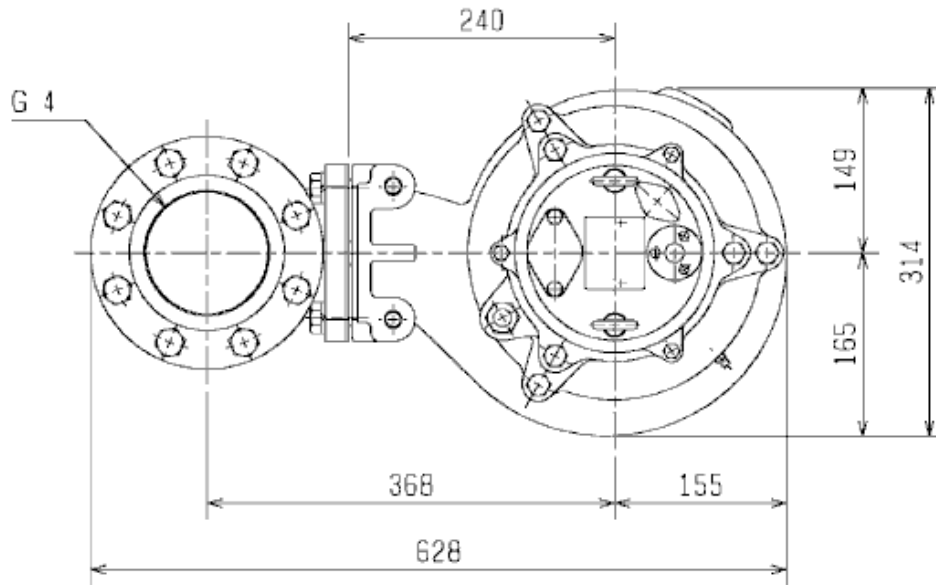

mm

100UZ43.7-51

CWL: Continuous running water level
LWL: Lowest running water level



Tsurumi Europe GmbH
19.06.2019 V.01.02.2019

Wahlerstr. 10 * 40472 Düsseldorf * Germany
Tel.: +49-211-4179373 sales@tsurumi.eu
Fax: +49-211-417937-480 www.tsurumi.eu

Sectional drawing 100UZ43.7-51

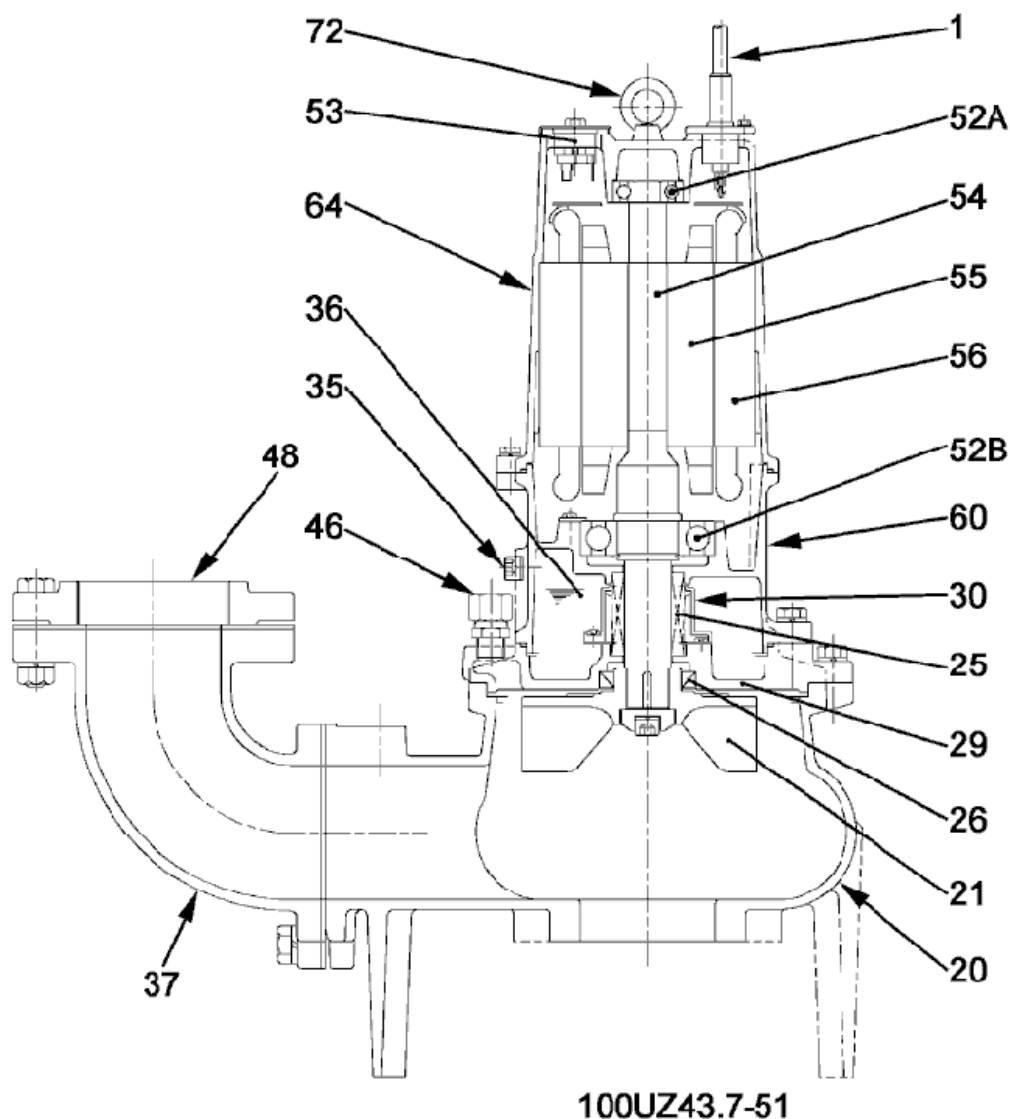

No.	Description	Remark	No.	Description	Remark
1	Cable	H07RN-F	55	Rotor	.
20	Pump casing	FC200 (EN-GJL-200)	56	Stator	.
21	Impeller	FC200 (EN-GJL-200)	60	Bearing Housing	FC150 (EN-GJL-150)
25	Mechanical seal	H-35A	64	Motor Frame	FC150 (EN-GJL-150)
26	Oil seal	TC507212	72	Eye screw (2x)	SUS304 (EN-X5CrNi18-10)
29	Oil casing	FC200 (EN-GJL-200)			
30	Oil distributor	Plastic			
35	Oil screw	SUS304 (EN-X5CrNi18-10)			
36	Lubricant	Turbine oil (ISO VG32)			
37	Discharge bend	FC200 (EN-GJL-200)			
46	Air vent screw	Brass			
48	Screwed Flange	FC200 (EN-GJL-200)			
52A	Upper bearing	6304ZZC3			
52B	Lower bearing	6309ZZC3			
53	Motor Protector 380/400/415V-50Hz	KA314-HRXL00 (H.C)			
54	Shaft	SUS420J2 (EN-X30Cr13)			