

Data sheet NKZ3-C3

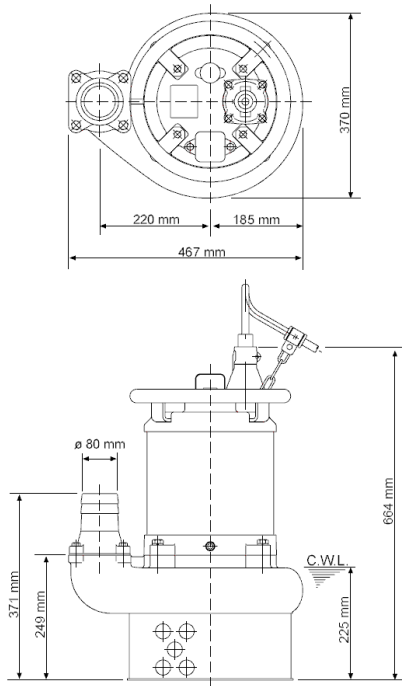

NKZ3-C3

CWL: Continuous running water level

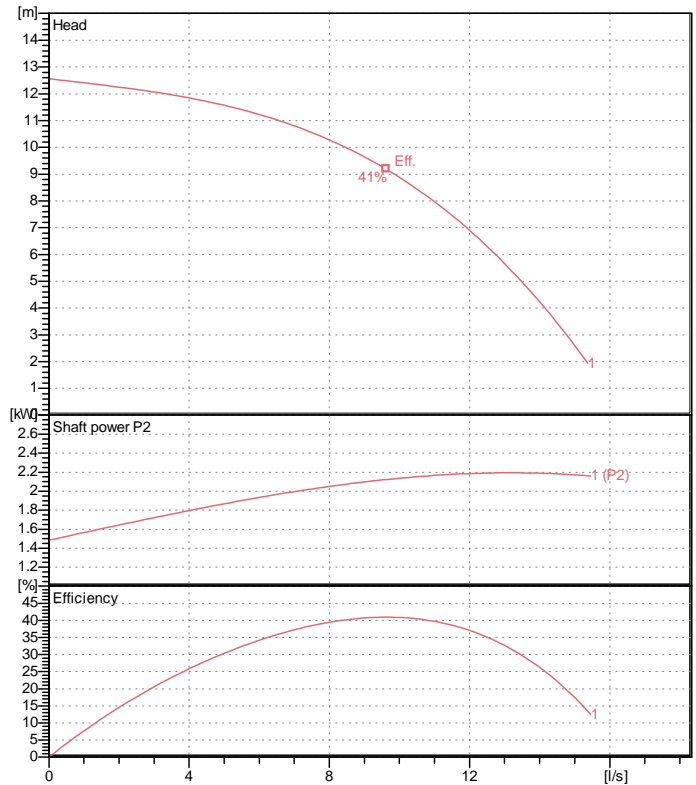

Specification

Electric submersible pump
 Degree of protection IP 68
 Depth of submersion max. 15 m
 Type of impeller Open
 Max. solid handling 30 mm
 Suitable for:
 sludge, slurry, liquids containing sand, bentonite

Electric motor

Dry-type submersible induction motor
 Insulation class E 4Poles 1420 1/min
 Starting mode Directly
 Rated voltage 400 V 50 Hz 3~
 Power uptake 3.00 kW
 Rated power 2.20 kW
 Rated current 5.1 A
 Start current 31.0 A

Cable

20m NSSHÖU 4Cx1,5mm²

Motor Protection

Circle thermal protector
 (snap-action bi-metal device)

Shaft seal

Double inside mechanical seal in oil bath
 additional lubrication by oil lifting device

Primary seal

Silicon carbide on silicon carbide

Secondary seal

Silicon carbide on silicon carbide

Bearings

Shielded ball bearings, maintenance-free

Materials

Impeller	FCD700 (EN-GJS-700-2)
Agitator	FCD700 (EN-GJS-700-2)
Pump casing	FC200 (EN-GJL-200)
Suction cover	FC200 (EN-GJL-200)
Motorgehäuse	FC150 (EN-GJL-150)
Shaft	SUS420J2 (EN-X30Cr13)

Discharge size

3" (80mm) BS-coupling (threaded flange)

Weight

91 kg (dry weight of the pump only without cable)

Performance curve

NKZ3-C3

Discharge port	3"
Head	12.6 m
Flow	15.4 l/s
Rated power	2.20 kW
Power input	3.00 kW
Phases	3~
Voltages	400 V
Frequency	50 Hz
Rated current	5.1 A
Starting current	31.01 A
Number of poles	4
Speed	1420 1/min
Starting mode	Directly
Insulation class	E

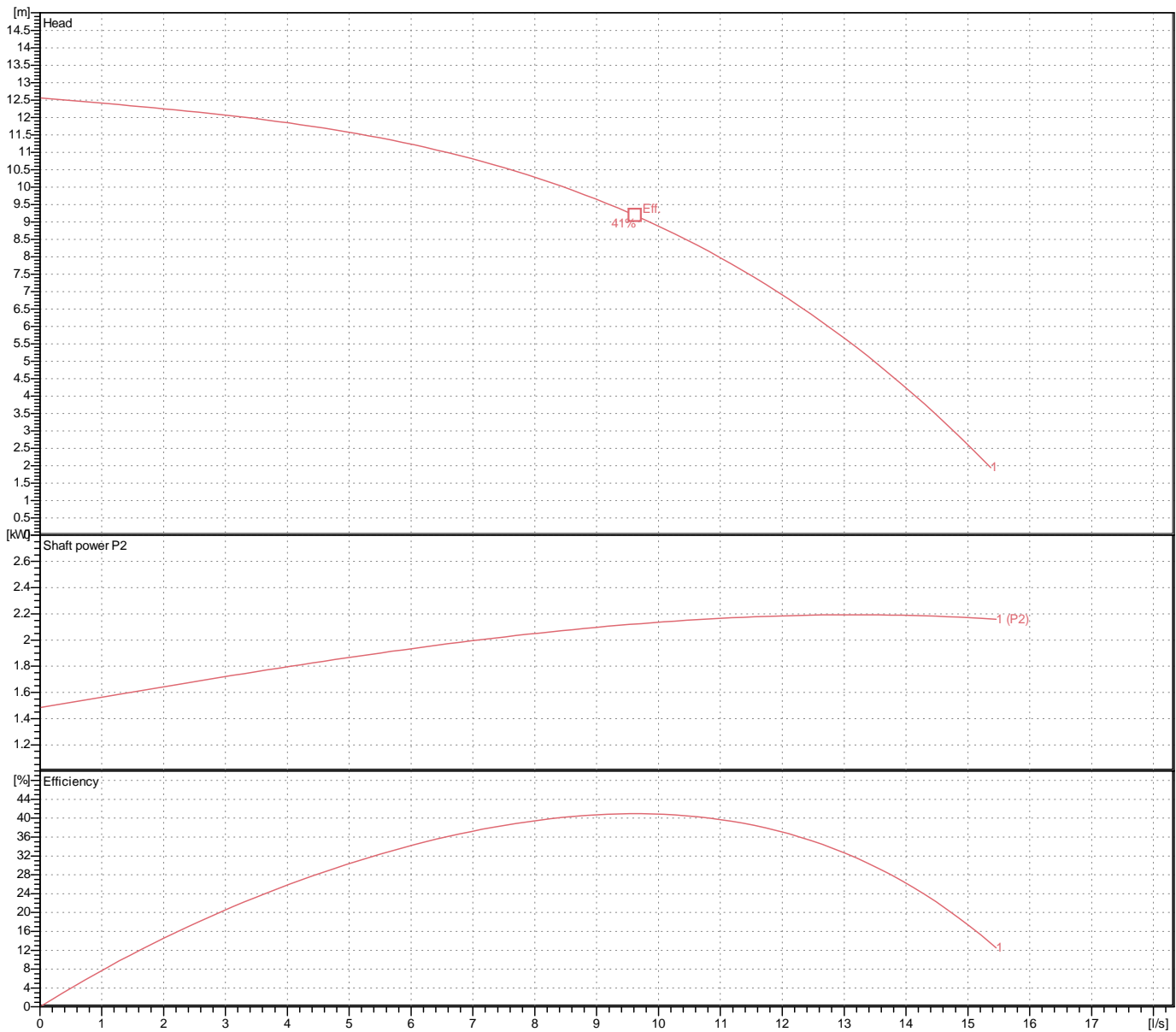

Dimensions NKZ3-C3

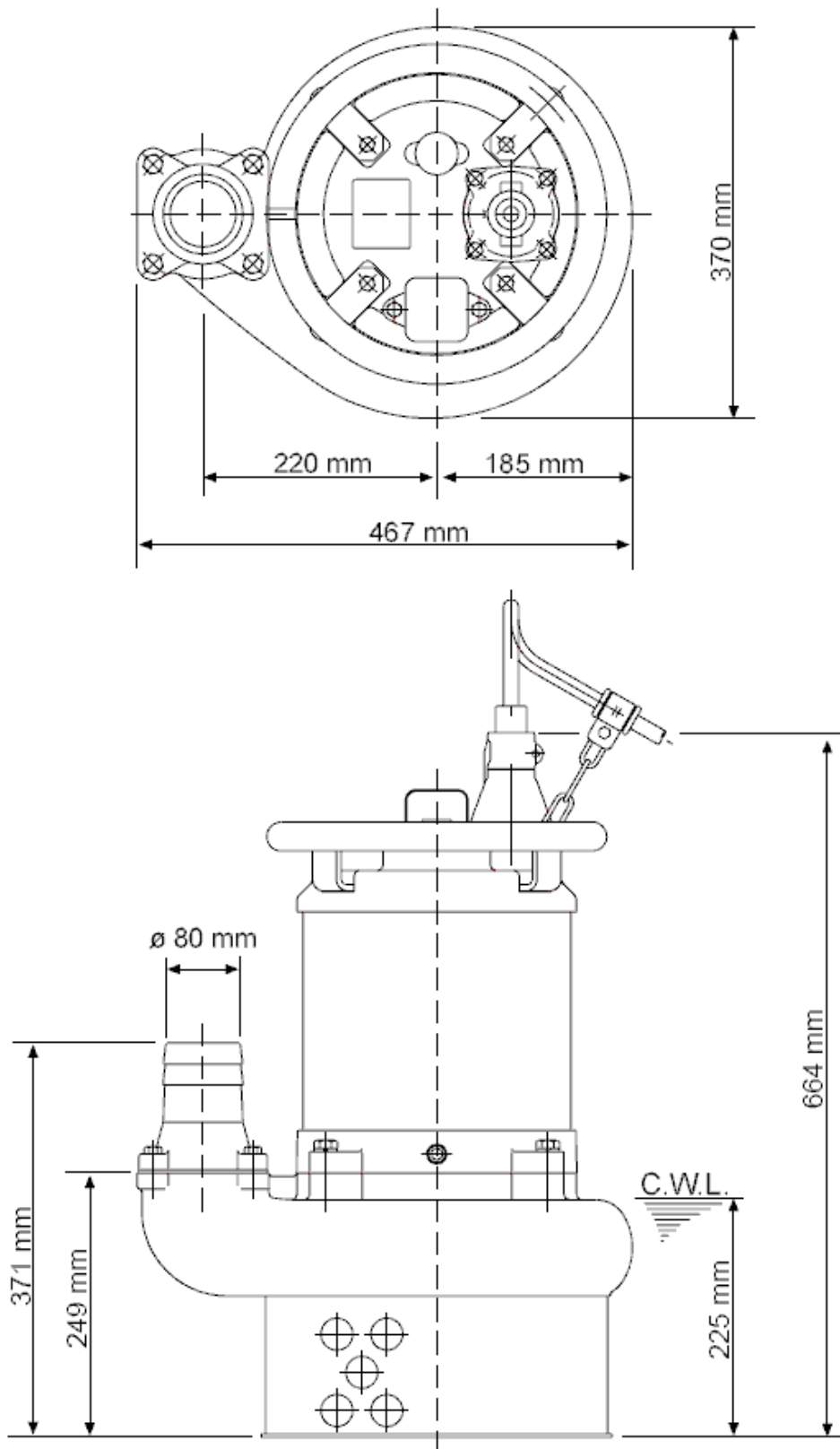

NKZ3-C3

CWL: Continuous running water level
LWL: Lowest running water level

 **TSURUMI PUMP**

Tsurumi Europe GmbH
 11.07.2018 V.18 / 1.10.2015

Heltorfer Str. 14 * 40472 Düsseldorf * Germany
 Tel.: +49-211-4179373 sales@tsurumi.eu
 Fax: +49-211-417937-480 www.tsurumi.eu

Sectional drawing NKZ3-C3

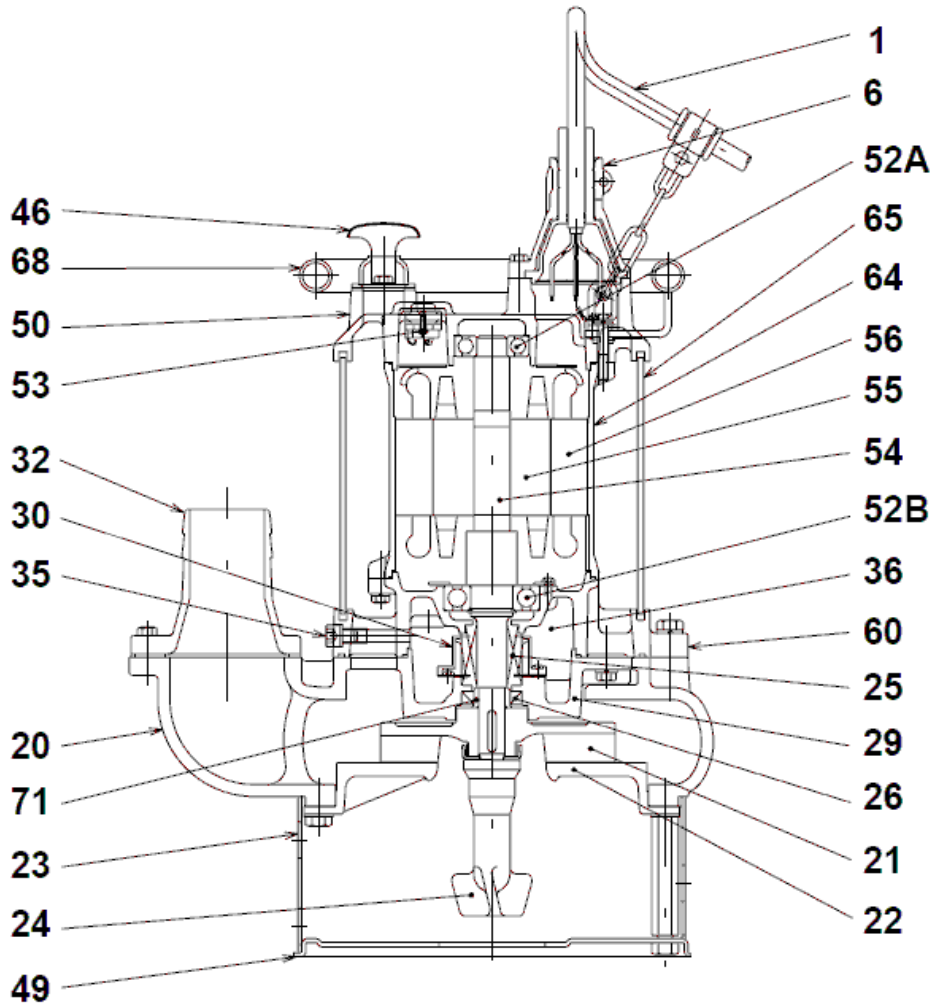

NKZ3-C3

No.	Description	Remark	No.	Description	Remark
1	Cable	20m NSSHÖU	52B	Lower bearing	6307ZZC3
6	Stuffing box	FC200 (EN-GJL-200)	53	Motor Protector 380/400/415V	50Hz KA314-HRXL00 (H.C)
20	Pump casing	FC200 (EN-GJL-200)	54	Shaft	SUS420J2 (EN-X30Cr13)
21	Impeller	FCD700 (EN-GJS-700-2)	55	Rotor	.
22	Suction cover	FC200 (EN-GJL-200)	56	Stator	.
23	Strainer	Steel plate	60	Lagergehäuse	FC150 (EN-GJL-150)
24	Agitator	FCD700 (EN-GJS-700-2)	64	Motorgehäuse	FC150 (EN-GJL-150)
25	Mechanical seal	H-25	65	Outer Cover	Construction steel SS400
26	Oil seal	DD305011	68	Handle	electroplated steel pipe
29	Oil casing	FC200 (EN-GJL-200)	71	Shaft protection sleeve	SUS403 (EN-X6Cr13)
32	Discharge coupling	FC200 (EN-GJL-200)			
35	Oil screw	SUS304 (EN-X5CrNi18-10)			
36	Lubricant	Turbine oil (ISO VG32)			
46	Air vent screw	Steel plate			
50	Motor cover	FC150 (EN-GJL-150)			
52A	Upper bearing	6305ZZC3			