

Data sheet KRS1022-51

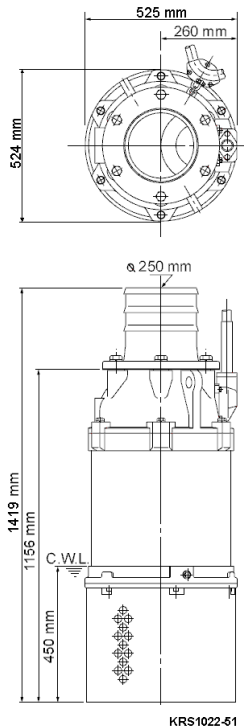

CWL: Continuous running water level

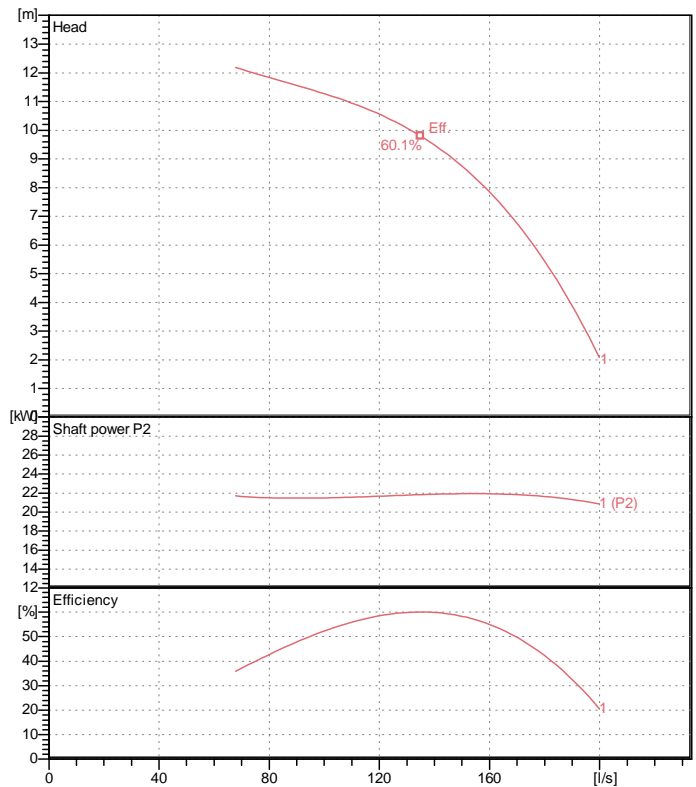

Specification

Electric submersible pump
 Degree of protection IP 68
 Depth of submersion max. 20 m
 Type of impeller Closed
 Max. solid handling 25 mm
 Suitable for:
 rain water, ground water, sand water

Electric motor

Dry-type submersible induction motor
 Insulation class B 4Poles 1440 1/min
 Starting mode Directly
 Rated voltage 400 V 50 Hz 3~
 Power uptake 27.71 kW
 Rated power 22.00 kW
 Rated current 45.7 A
 Start current 256.8 A

Cable

20m NSSHÖU 4Cx10mm²

Motor Protection

Circle thermal protector
 (snap-action bi-metal device)

Shaft seal

Double inside mechanical seal in oil bath
 additional lubrication by oil lifting device

Primary seal
 Silicon carbide on silicon carbide
 Secondary seal
 Silicon carbide on silicon carbide

Bearings

Shielded ball bearings, maintenance-free

Materials

Impeller	FCD700 (EN-GJS-700-2)
Pump casing	FC200 (EN-GJL-200)
Suction cover	FC200 (EN-GJL-200)
Motor Frame	FC200 (EN-GJL-200)
Shaft	SUS420J2 (EN-X30Cr13)

Discharge size

10" (250mm) hose coupling

Weight

390 kg (dry weight of the pump only without cable)

Performance curve KRS1022-51

Discharge port	10"
Head	12.2 m
Flow	199.9 l/s
Rated power	22.00 kW
Power input	27.71 kW
Phases	3~
Voltages	400 V
Frequency	50 Hz
Rated current	45.7 A
Starting current	256.83 A
Number of poles	4
Speed	1440 1/min
Starting mode	Directly
Insulation class	B

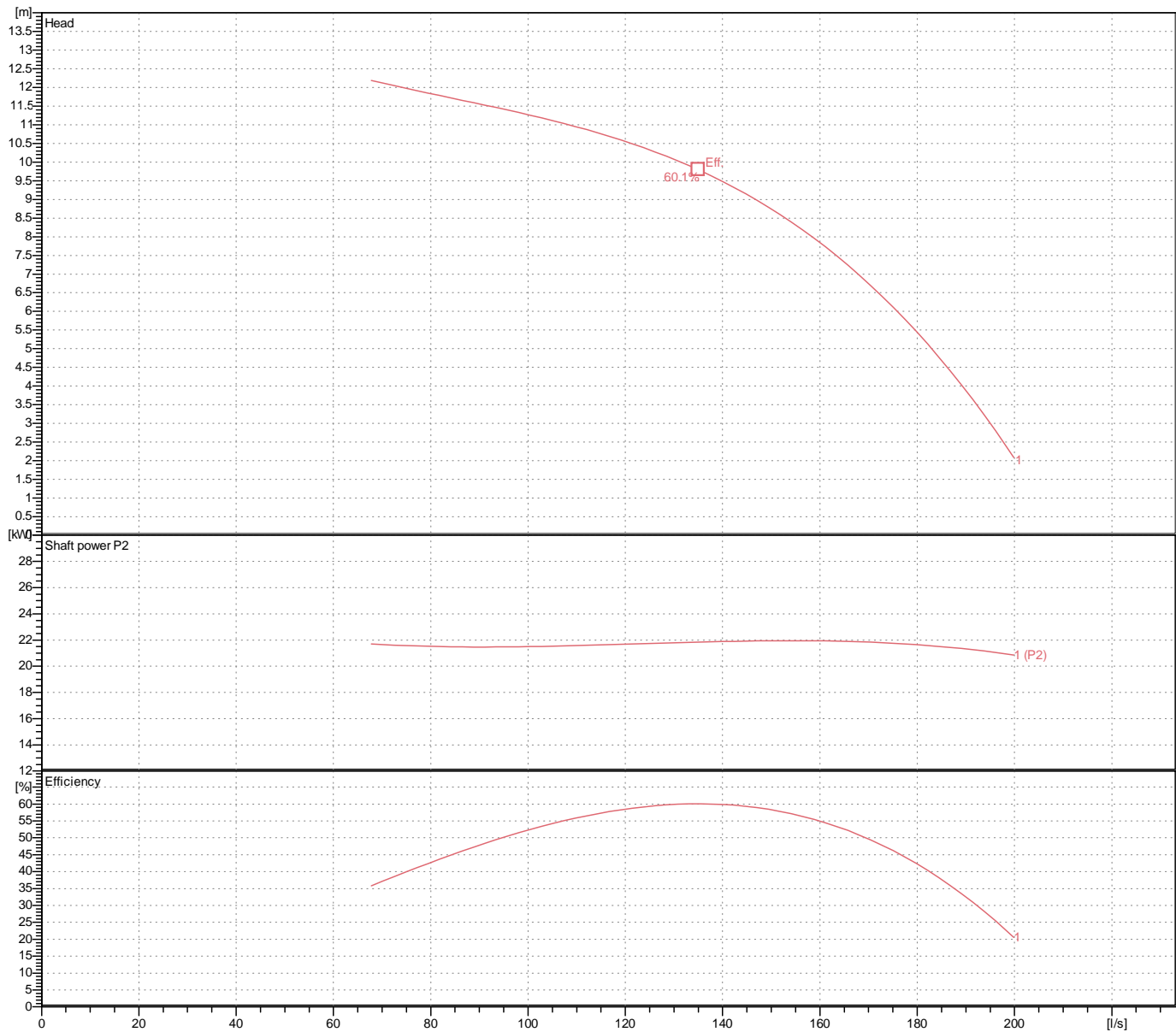

Dimensions

KRS1022-51

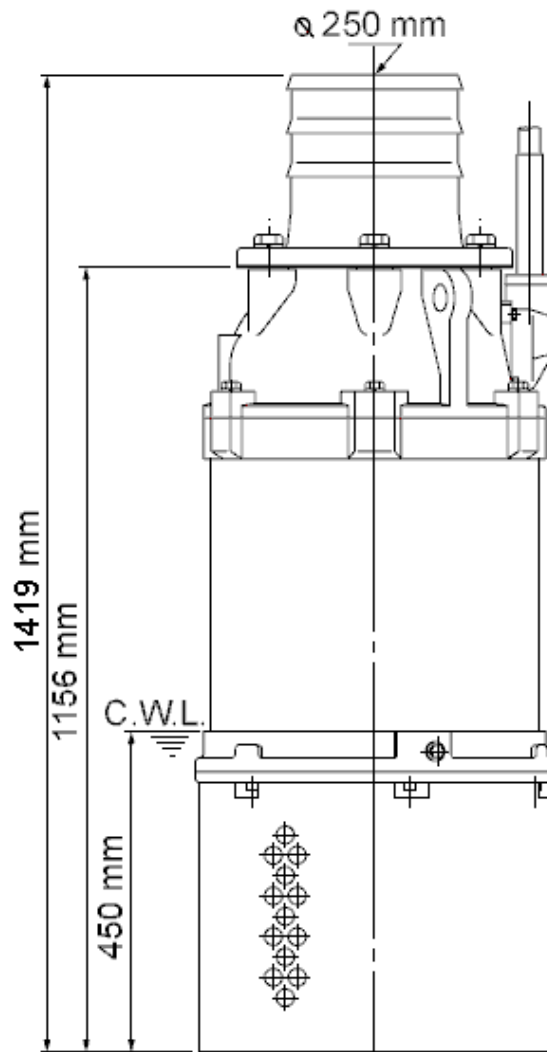
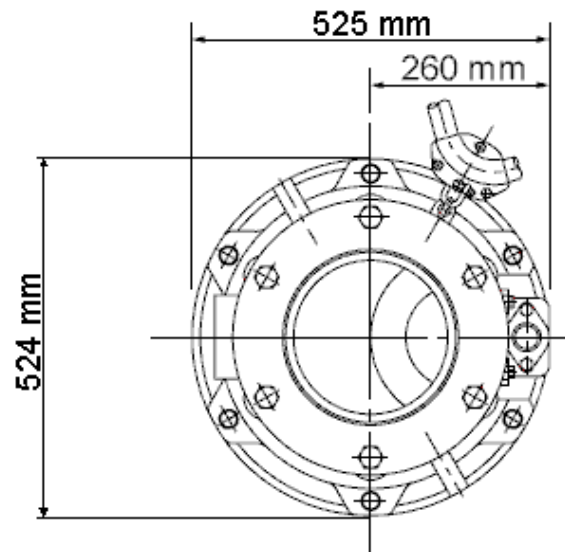

KRS1022-51

CWL: Continuous running water level
LWL: Lowest running water level

Sectional drawing KRS1022-51

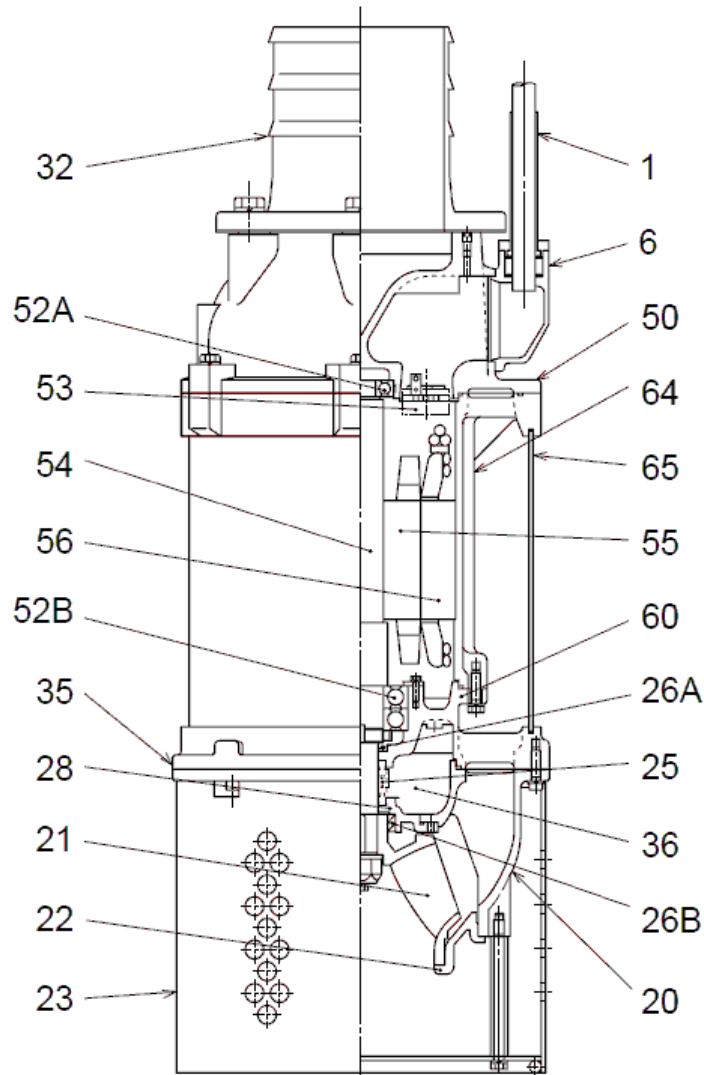

KRS1022-51

No.	Description	Remark	No.	Description	Remark
1	Cable	20m NSSHÖU	53	Motor Protector 380/400/415V-50Hz KA314-HRXL00 (H.C)	
6	Stuffing box	FC200 (EN-GJL-200)	54	Shaft	SUS420J2 (EN-X30Cr13)
20	Pump casing	FC200 (EN-GJL-200)	55	Rotor	.
21	Impeller	FCD700 (EN-GJS-700-2)	56	Stator	.
22	Suction cover	FC200 (EN-GJL-200)	60	Bearing Housing	FC200 (EN-GJL-200)
23	Strainer	Construction steel SS400	64	Motor Frame	FC200 (EN-GJL-200)
25	Mechanical seal	H-45	65	Outer Cover	Construction steel SS400
26A	Oil seal	SC456812			
26B	Oil seal	TC709212			
28	Seal casing	FC200 (EN-GJL-200)			
32	Discharge coupling	FC200 (EN-GJL-200)			
35	Oil screw	SUS304 (EN-X5CrNi18-10)			
36	Lubricant	Turbine oil (ISO VG32)			
50	Main cover	FC200 (EN-GJL-200)			
52A	Upper bearing	6308ZZC3			
52B	Lower bearing	6312ZZD2C3			