

Data sheet GPN622-51

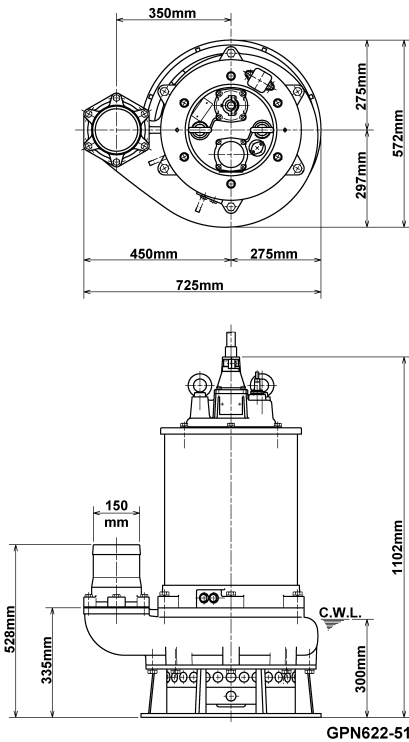

CWL: Continuous running water level

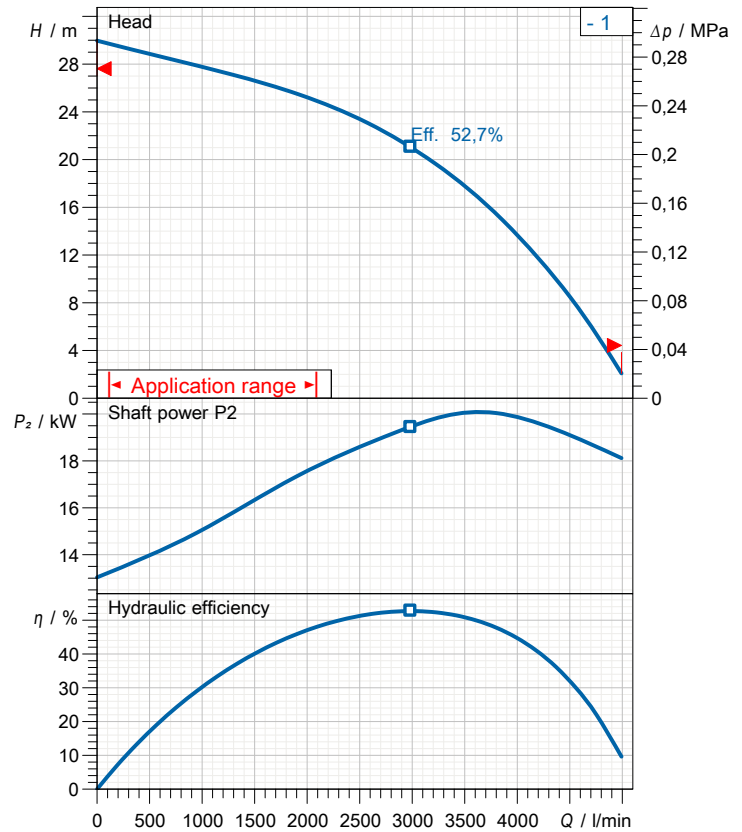

Specification

Elektrische Tauchpumpe GPN-Serie
 Degree of protection IP 68
 Pressure resistance max. 30 m
 Type of impeller Open
 Max. solid handling 30 mm
 Suitable for:
 sludge, slurry, liquids containing sand

Electric motor

Dry-type submersible induction motor
 Insulation class F 4Poles 1455 1/min
 Starting mode Direct starting
 Rated voltage 400 V 50 Hz 3~
 Power uptake 24,92 kW
 Rated power 22,00 kW
 Rated current 42,5 A
 Start current 289,9 A

Cable

20m NSSHÖU 4Cx10mm²+3x1,5ST

Motor Protection

Circle thermal protector
 (snap-action bi-metal device)

Shaft seal

Double inside mechanical seal in oil bath
 additional lubrication by oil lifting device
 Primary seal
 Silicon carbide on silicon carbide
 Secondary seal
 SUS420J2 (EN-X30Cr13)

Bearings

Shielded ball bearings, maintenance-free

Materials

Impeller	Chromium iron casting
Agitator	Chromium iron casting
Pump casing	FC200 (EN-GJL-200)
Suction cover	FC200 (EN-GJL-200)
Motor Frame	FC150 (EN-GJL-150)
Shaft	DIN 1.7220 (chromium molybdenum)

Discharge size

6" (150mm) BS-coupling (threaded flange)

Weight

415 kg (dry weight of the pump only without cable)

Dimensions

GPN622-51

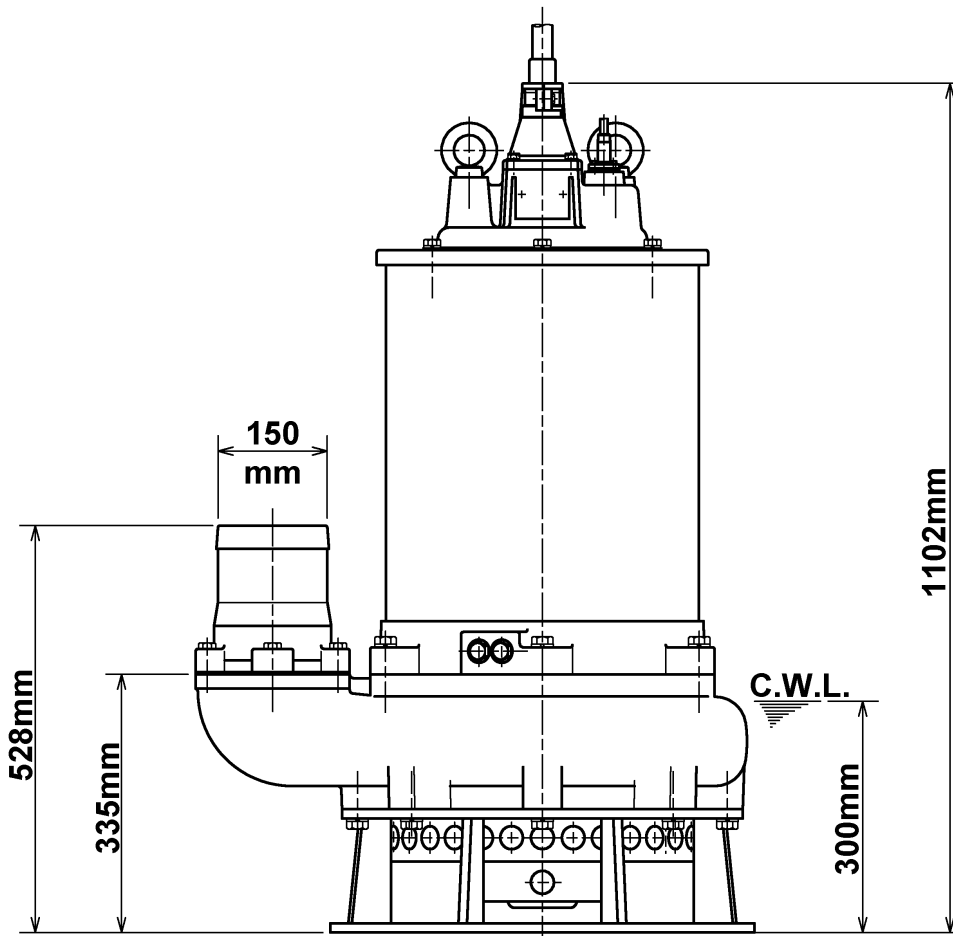
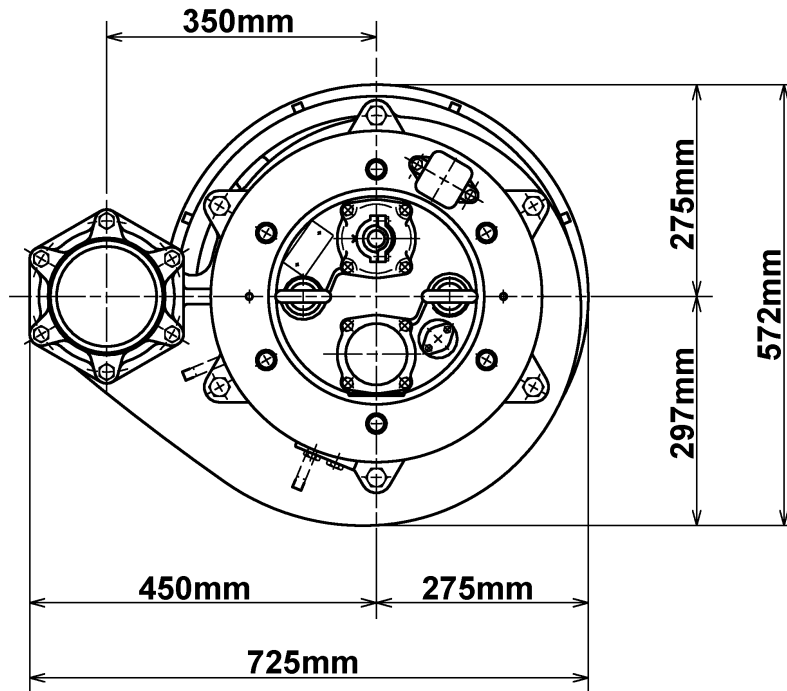

GPN622-51

CWL: Continuous running water level
 LWL: Lowest running water level

Sectional drawing

GPN622-51

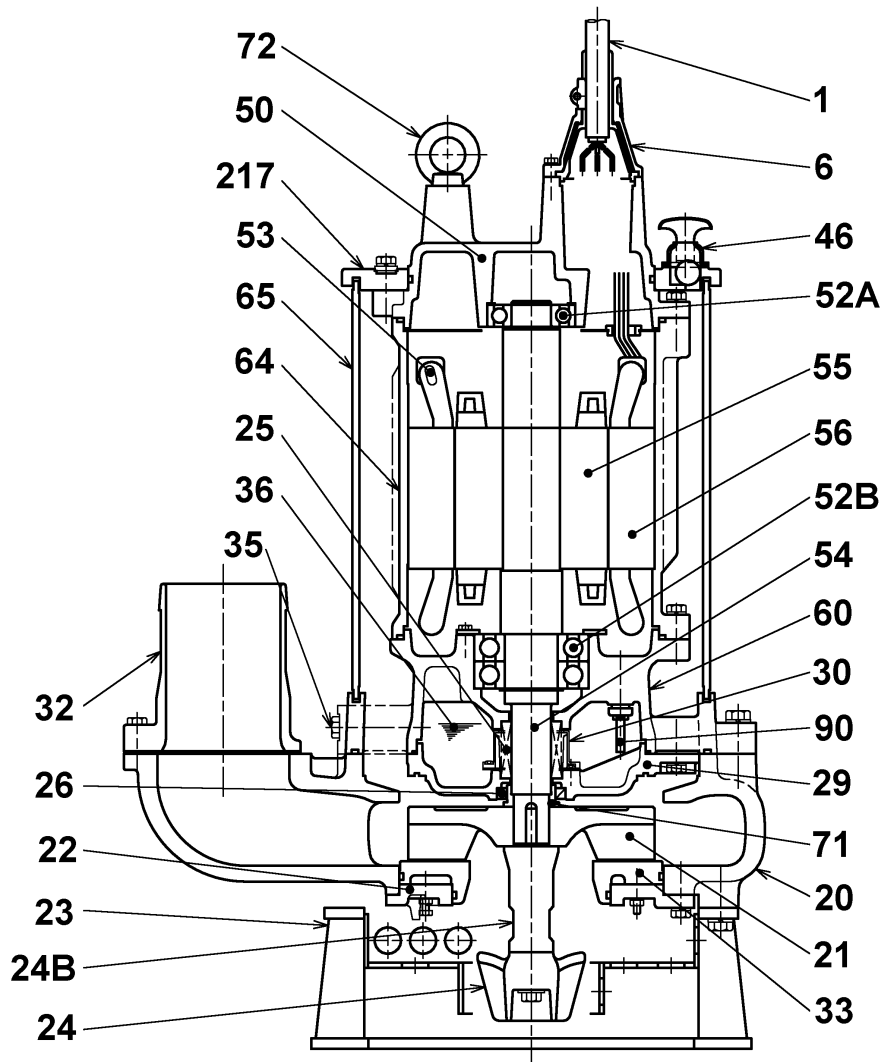

GPN622-51

No.	Description	Remark	No.	Description	Remark
1	Cable	20m NSSHÖU	46	Air vent valve	Steel plate
6	Stuffing box	FC200 (EN-GJL-200)	50	Motor cover	FC150 (EN-GJL-150)
20	Pump casing	FC200 (EN-GJL-200)	52A	Upper bearing	6309ZZC3
21	Impeller	Chromium iron casting	52B	Lower bearing	6312ZZD2C3
22	Suction cover	FC200 (EN-GJL-200)	53	Circle thermal protector (3x)	.
23	Strainer	Steel plate / steel pipe	54	Shaft	DIN 1.7220 (chromium molybdenum)
24	Agitator	Chromium iron casting	55	Rotor	.
24B	Connection rod	Black malleable cast iron hardened	56	Stator	.
25	Mechanical seal	H-50X	60	Bearing Housing	FC150 (EN-GJL-150)
26	Oil seal	TC-608212	64	Motor Frame	FC150 (EN-GJL-150)
29	Oil casing	FC200 (EN-GJL-200)	65	Outer Cover	Steel plate SPCC
30	Oil distributor	Plastic	71	Shaft protection sleeve	SUS403 (EN-X6Cr13)
32	Discharge coupling	FC200 (EN-GJL-200)	72	Eye screw	Construction steel SS400
33	Suction cover	Chromium iron casting	90	Density sensor	.
35	Oil screw	SUS304 (EN-X5CrNi18-10)	217	Fixing plate	FC150 (EN-GJL-150)
36	Lubricant	Turbine oil (ISO VG32)			