

# Data sheet GPN415-51

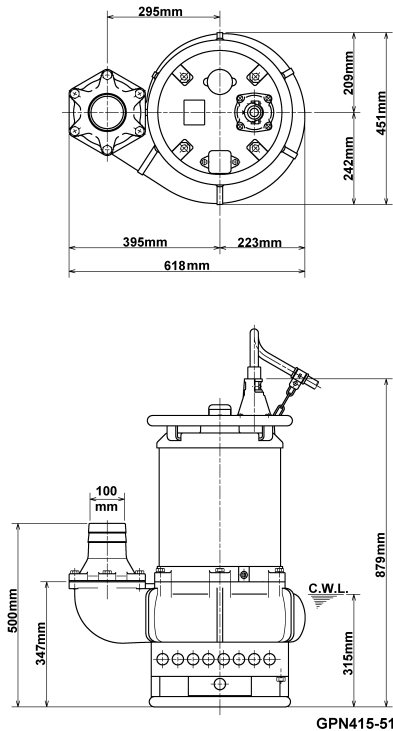

GPN415-51

CWL: Continuous running water level

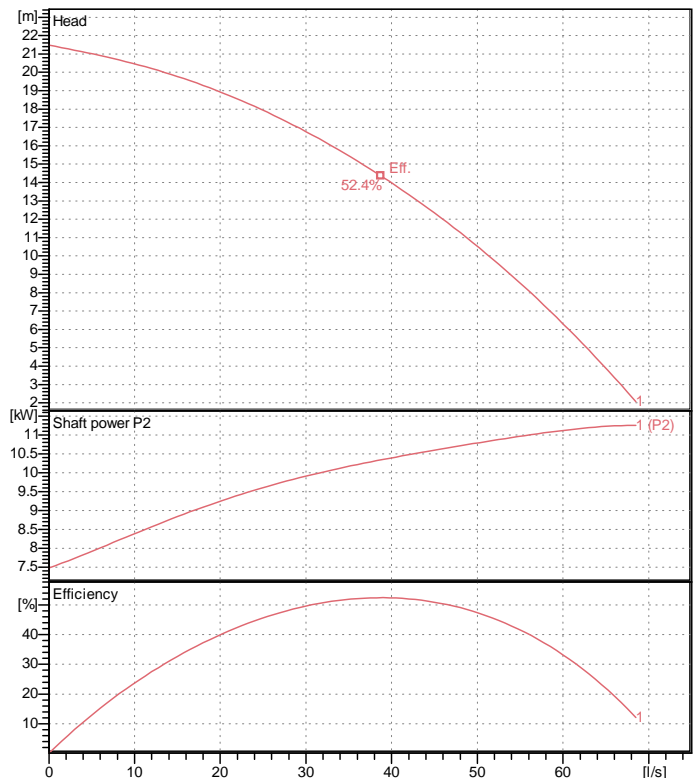

## Specification

Electric submersible pump  
 Degree of protection IP 68  
 Depth of submersion max. 20 m  
 Type of impeller Open  
 Max. solid handling 30 mm  
 Suitable for:  
 sludge, slurry, liquids containing sand

## Electric motor

Dry-type submersible induction motor  
 Insulation class B 4Poles 1450 1/min  
 Starting mode Directly  
 Rated voltage 400 V 50 Hz 3~  
 Power uptake 15.81 kW  
 Rated power 15.00 kW  
 Rated current 25.8 A  
 Start current 163.1 A

## Cable

20m NSSHÖU 4Cx6mm<sup>2</sup>

## Motor Protection

Circle thermal protector  
 (snap-action bi-metal device)

## Shaft seal

Double inside mechanical seal in oil bath  
 additional lubrication by oil lifting device

Primary seal  
 Silicon carbide on silicon carbide  
 Secondary seal  
 SUS420J2 (EN-X30Cr13)

## Bearings

Shielded ball bearings, maintenance-free

## Materials

Impeller	Chromium iron casting
Agitator	Chromium iron casting
Pump casing	FC200 (EN-GJL-200)
Suction cover	FC200 (EN-GJL-200)
Motor Frame	FC150 (EN-GJL-150)
Shaft	DIN 1.7220 (chromium molybdenum)

## Discharge size

4" (100mm) BS-coupling (threaded flange)

## Weight

220 kg (dry weight of the pump only without cable)

# Performance curve

## GPN415-51

Discharge port	4"
Head	21.5 m
Flow	68.5 l/s
Rated power	15.00 kW
Power input	15.81 kW
Phases	3~
Voltages	400 V
Frequency	50 Hz
Rated current	25.8 A
Starting current	163.06 A
Number of poles	4
Speed	1450 1/min
Starting mode	Directly
Insulation class	B

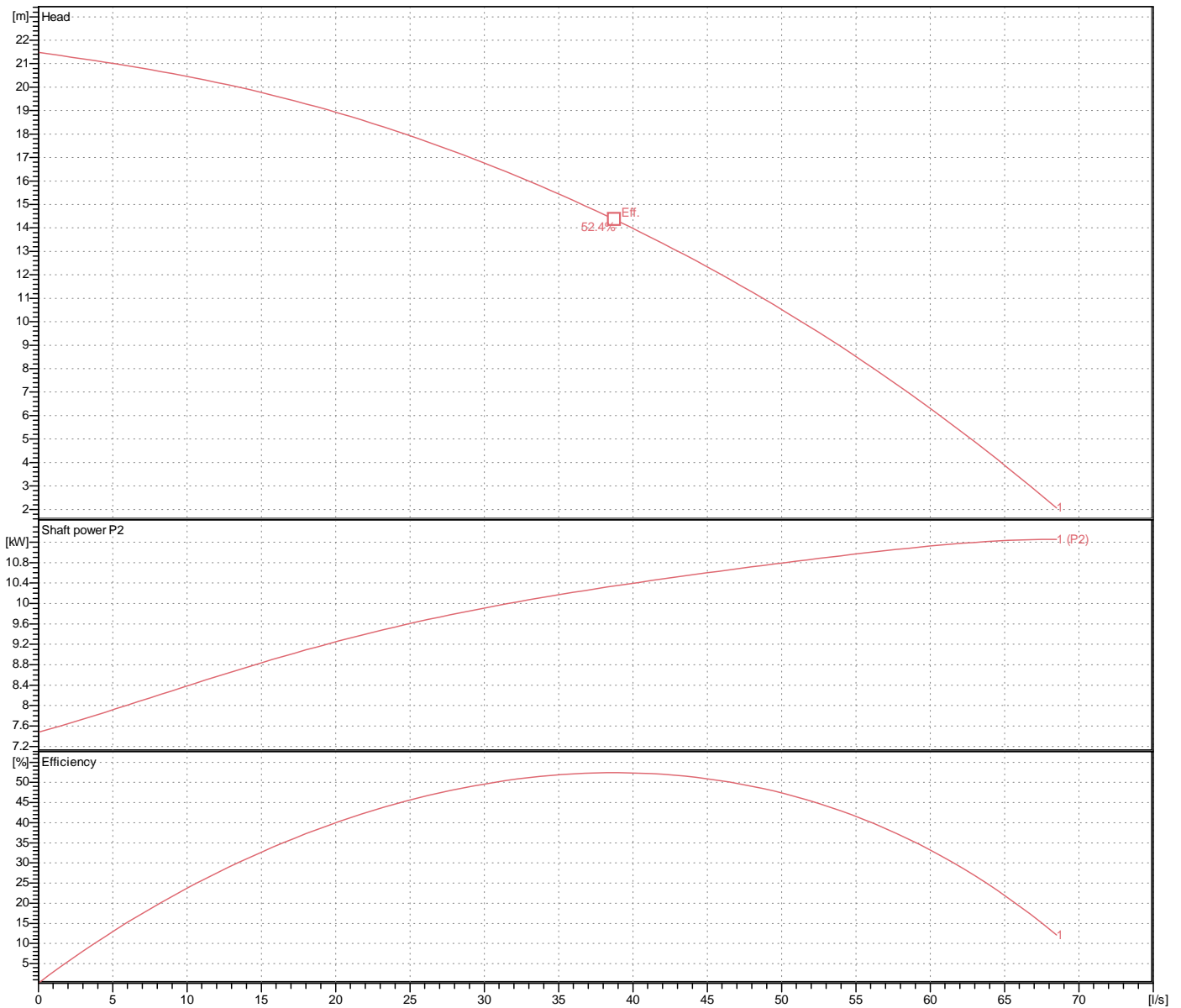

# Dimensions GPN415-51

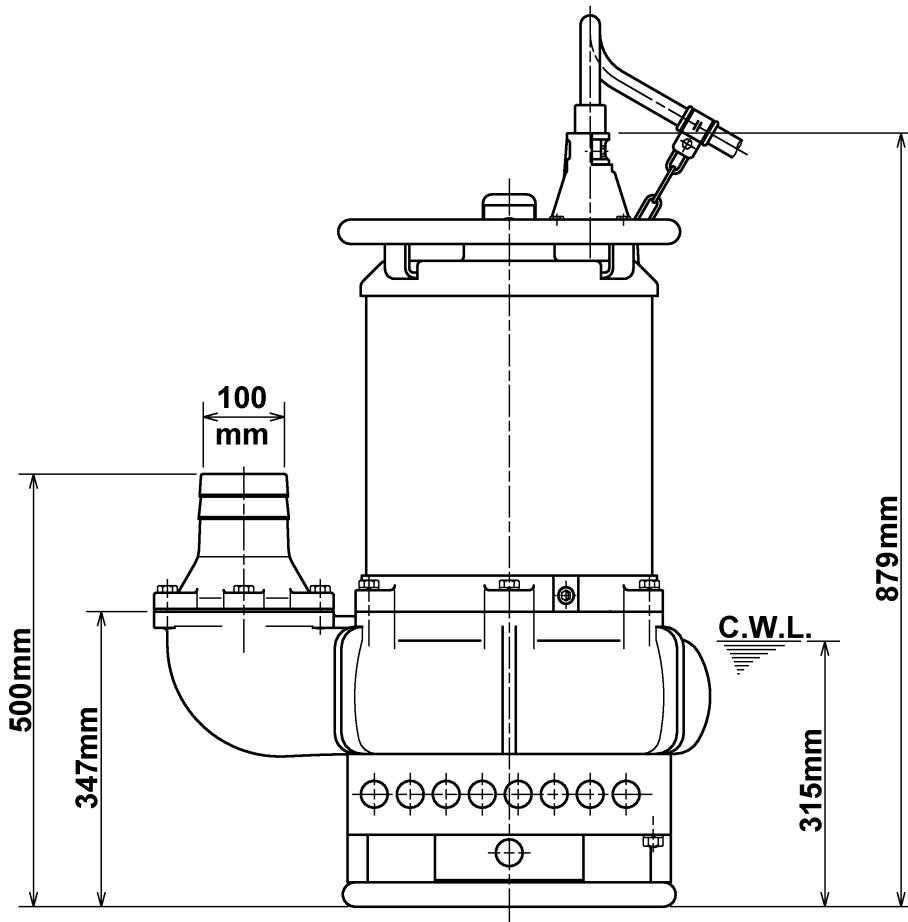
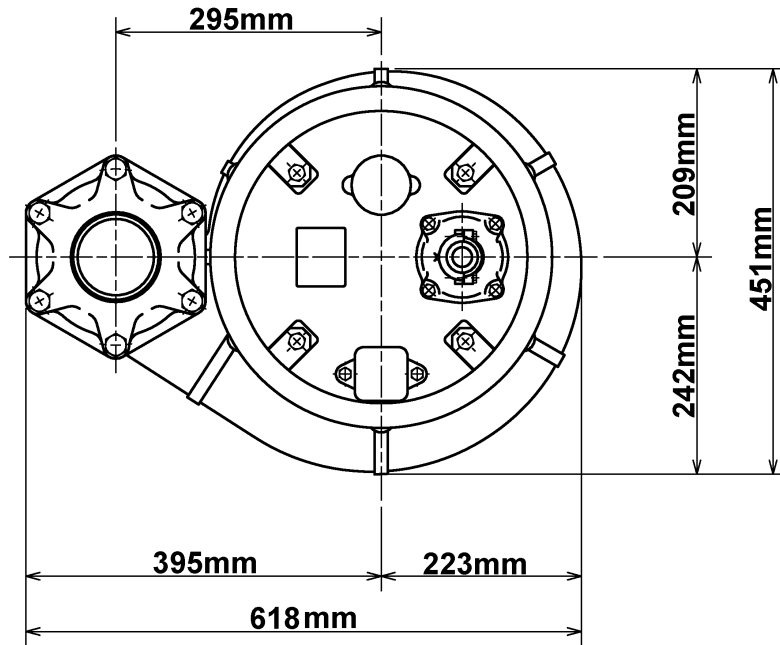

**GPN415-51**

**CWL: Continuous running water level**  
**LWL: Lowest running water level**

# Sectional drawing GPN415-51

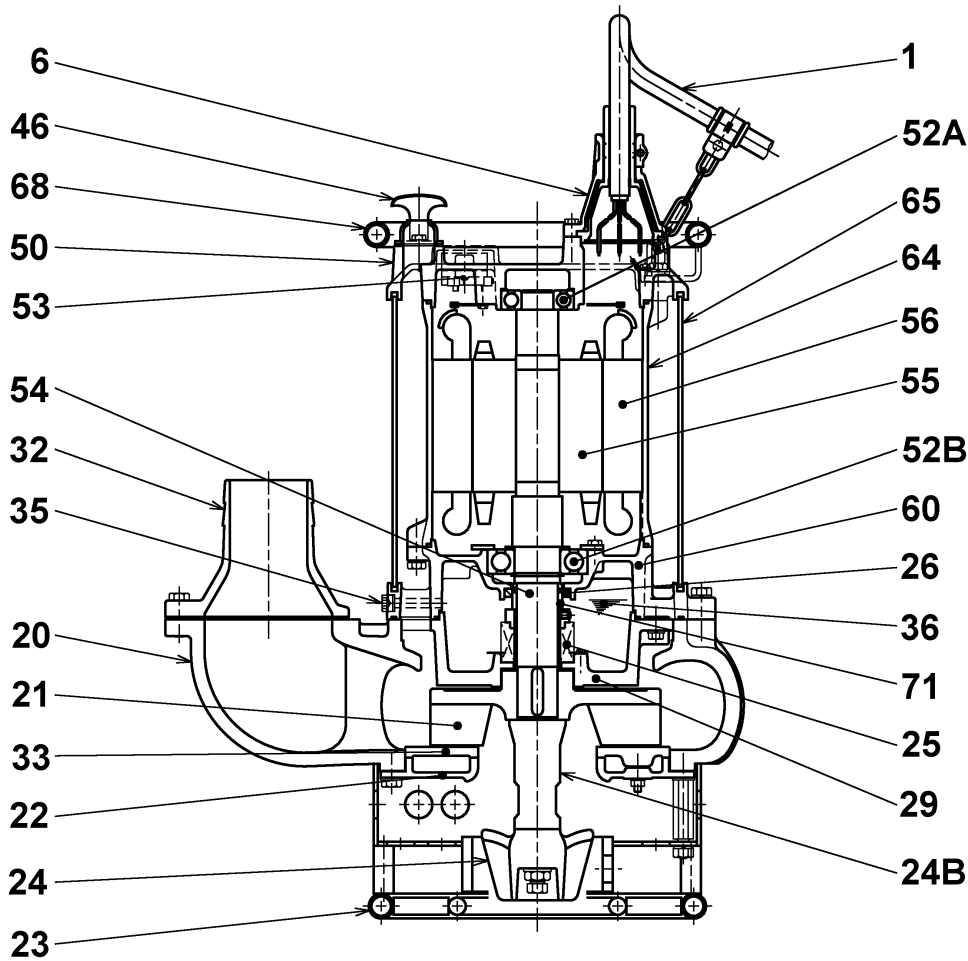

**GPN415-51**

No.	Description	Remark	No.	Description	Remark
1	Cable	20m NSSHÖU	50	Motor cover	FC 150 (EN-GJL-150)
6	Stuffing box	FC200 (EN-GJL-200)	52A	Upper bearing	6307ZC3
20	Pump casing	FC200 (EN-GJL-200)	52B	Lower bearing	6310ZC3
21	Impeller	Chromium iron casting	53	Circle thermal protector (3x)	.
22	Suction cover	FC200 (EN-GJL-200)	54	Shaft	DIN 1.7220 (chromium molybdenum)
23	Strainer	Steel plate / steel pipe	55	Rotor	.
24	Agitator	Chromium iron casting	56	Stator	.
24B	Connection rod	Black malleable cast iron hardened	60	Bearing Housing	FC 150 (EN-GJL-150)
25	Mechanical seal	NH-50	64	Motor Frame	FC 150 (EN-GJL-150)
26	Oil seal	TC-55729	65	Outer Cover	Steel plate SPCC
29	Oil casing	FC200 (EN-GJL-200)	68	Carrier handle	SUS304 (EN-X5CrNi18-10)
32	Discharge coupling	FC200 (EN-GJL-200)	71	Shaft protection sleeve	SUS403 (EN-X6Cr13)
33	Suction cover	Chromium iron casting			
35	Oil screw	SUS304 (EN-X5CrNi18-10)			
36	Lubricant	Turbine oil (ISO VG32)			
46	Air vent valve	Steel plate			