

Data sheet 100B43.7H-53

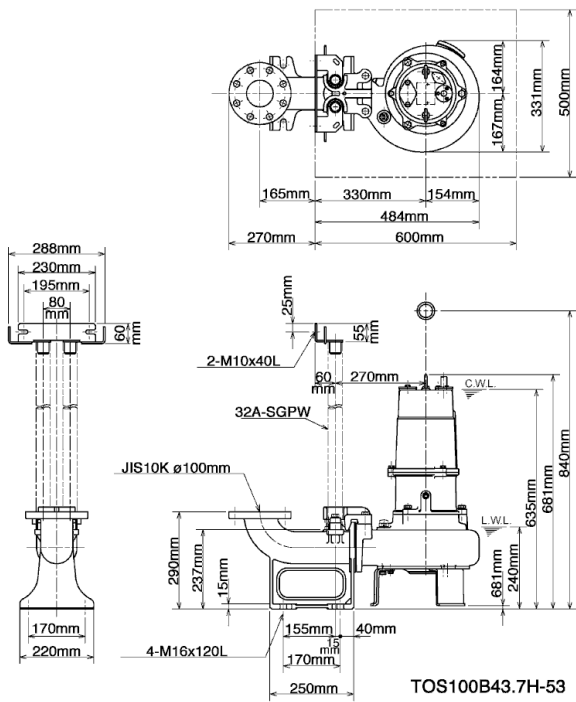

CWL: Continuous running water level
LWL: Lowest running water level

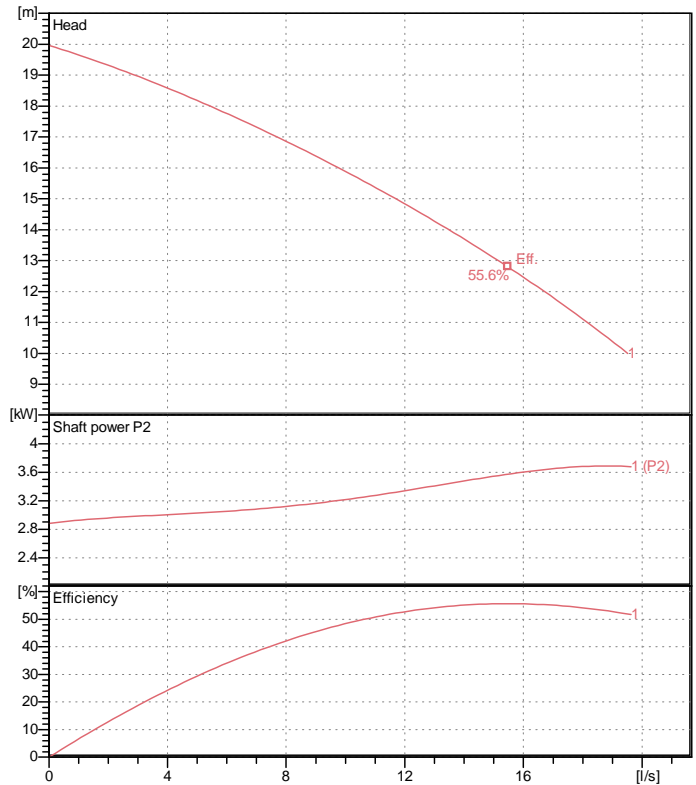

Specification

Electric submersible pump
Degree of protection IP 68
Depth of submersion max. 15 m
Type of impeller Single channel impeller
Free passage 35 mm
Suitable for:
sewage water

Electric motor

Dry-type submersible induction motor
Insulation class E 4Poles 1410 1/min
Starting mode Directly
Rated voltage 400 V 50 Hz 3~
Power uptake 4.59 kW
Rated power 3.70 kW
Rated current 7.9 A
Start current 49.0 A

Cable

10m H07RN-F 4Cx1,5mm²

Motor Protection

Circle thermal protector
(snap-action bi-metal device)

Shaft seal

Double inside mechanical seal in oil bath
additional lubrication by oil lifting device

Primary seal
Silicon carbide on silicon carbide
Secondary seal
Ceramic on carbon

Bearings

Shielded ball bearings, maintenance-free

Materials

Impeller	FC200 (EN-GJL-200)
Pump casing	FC200 (EN-GJL-200)
Suction cover	FCD700 (EN-GJS-700-2)
Motor Frame	FC200 (EN-GJL-200)
Shaft	SUS420J2 (EN-X30Cr13)

Discharge size

4" (100mm) JIS 10K screwed-in mating flange
guide rail fitting optional

Weight

78 kg (dry weight of the pump only without cable)

Performance curve

100B43.7H-53

Discharge port	4"
Head	20.0 m
Flow	19.5 l/s
Rated power	3.70 kW
Power input	4.59 kW
Phases	3~
Voltages	400 V
Frequency	50 Hz
Rated current	7.9 A
Starting current	48.98 A
Number of poles	4
Speed	1410 1/min
Starting mode	Directly
Insulation class	E

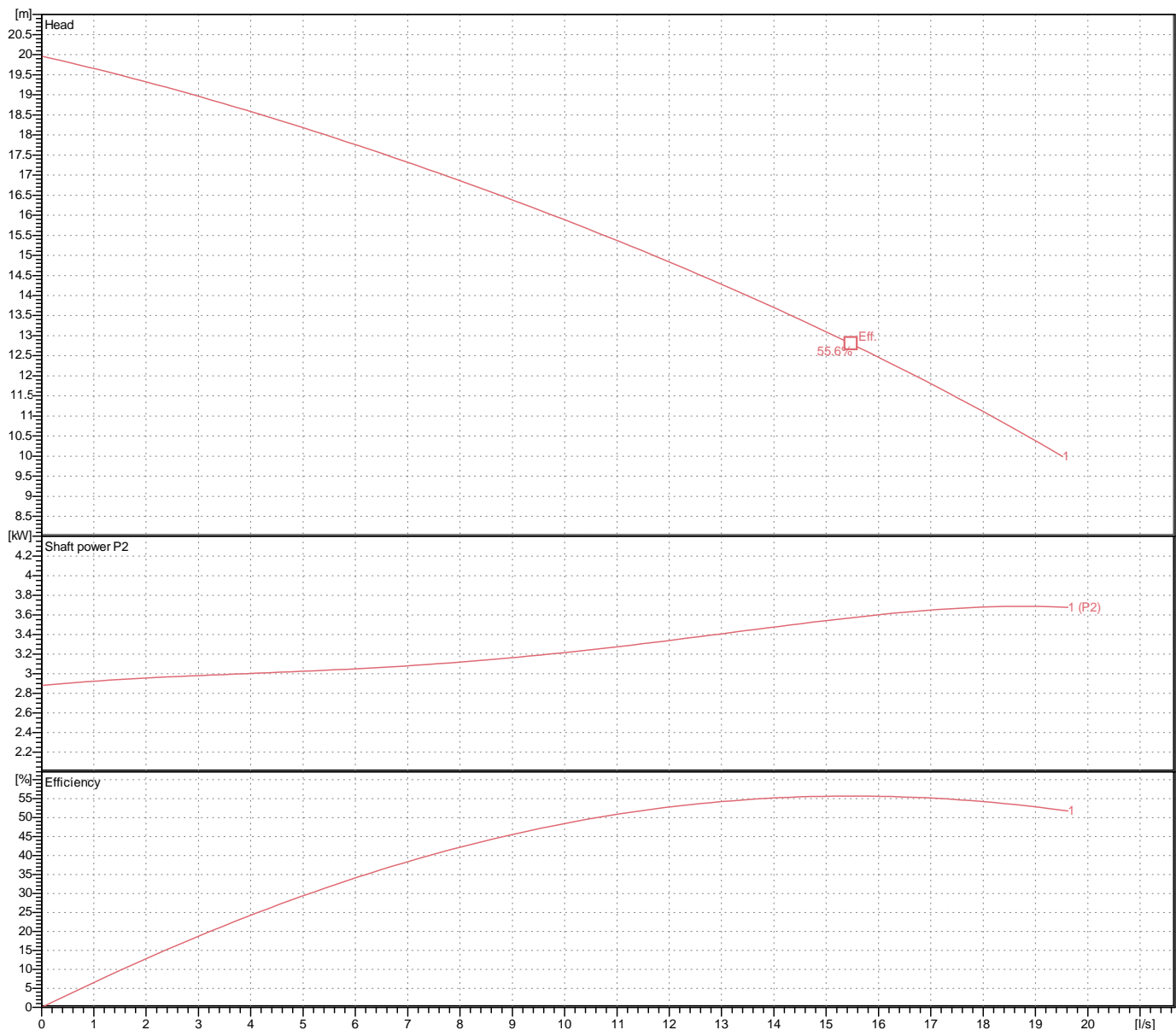

Dimensions

TOS100B43.7H-53

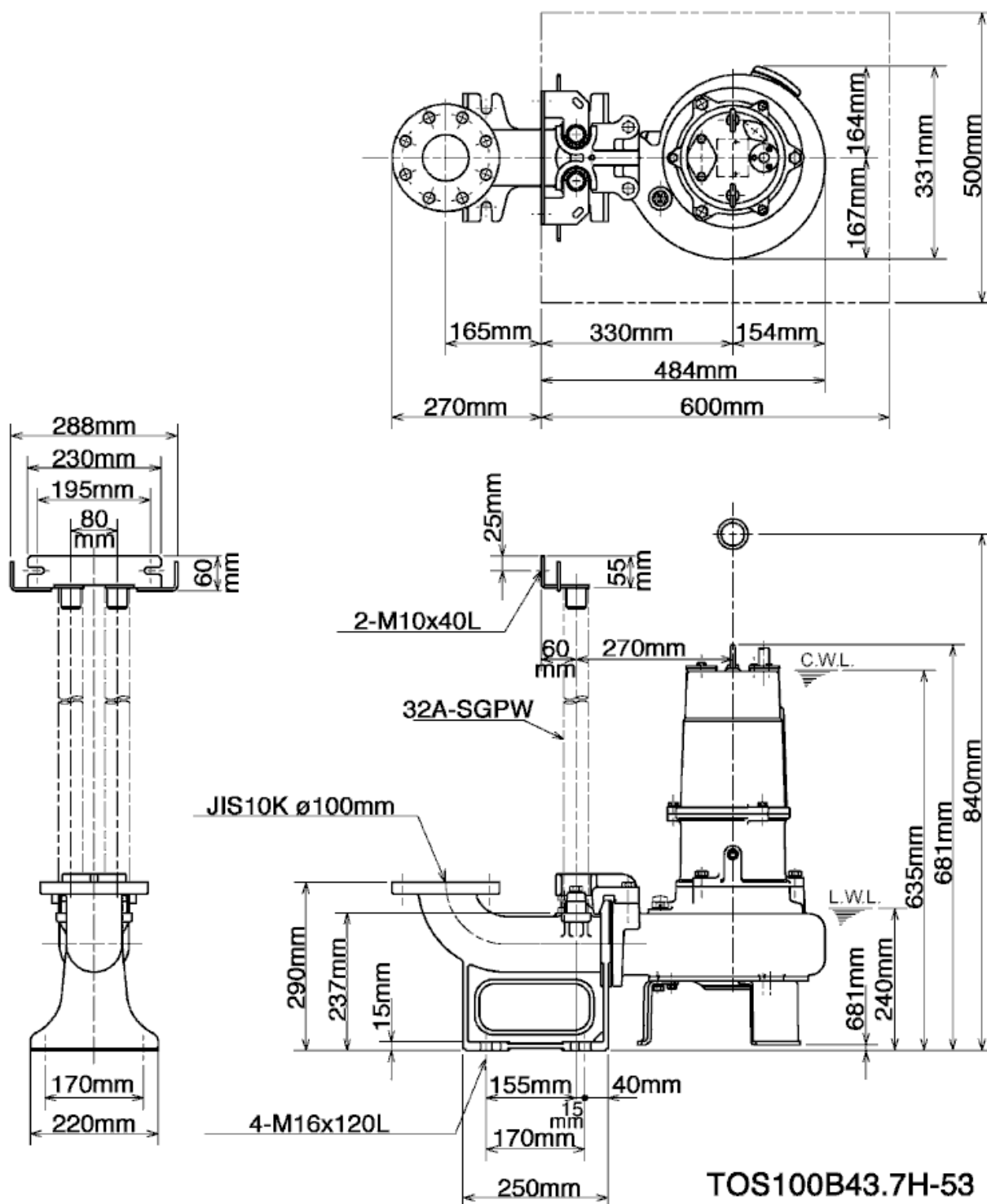

TOS100B43.7H-53

CWL: Continuous running water level
 LWL: Lowest running water level

Sectional drawing TOS100B43.7H-53

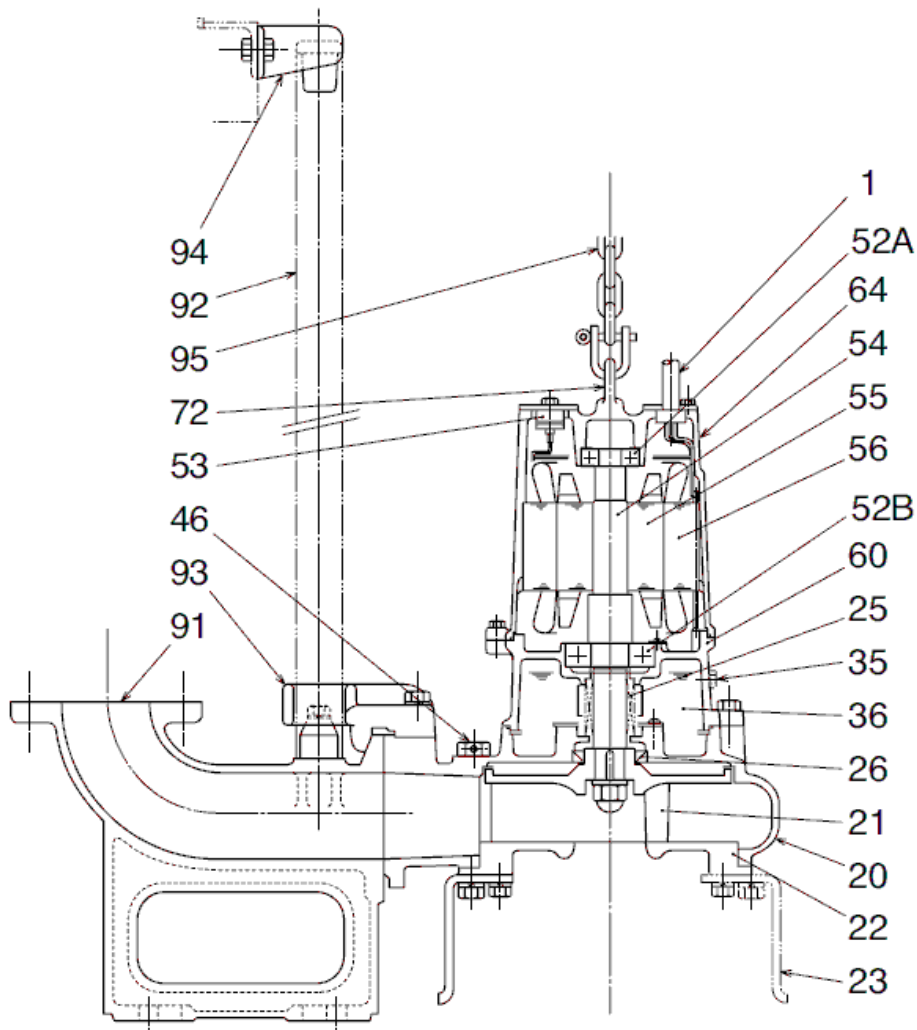

TOS100B43.7H-53

No.	Description	Remark	No.	Description	Remark
1	Cable	H07RN-F	56	Stator	.
20	Pump casing	FC200 (EN-GJL-200)	60	Bearing Housing	FC200 (EN-GJL-200)
21	Impeller	FC200 (EN-GJL-200)	64	Motor Frame	FC200 (EN-GJL-200)
22	Suction cover	FCD700 (EN-GJS-700-2)	72	Eye screw (2x)	SUS304 (EN-X5CrNi18-10)
23	Stand support (3x)	Construction steel SS400	91	duck foot bend	FC200 (EN-GJL-200)
25	Mechanical seal	H-35A	92	Guide pipe (option) (2x)	Galvanized steel pipe
26	Oil seal	TC507212	93	guide support	FCD45 (EN-GJS-450-10)
30	Oil distributor	Plastic	94	Guide pipe holder	SUS304 (EN-X5CrNi18-10)
35	Oil screw	SUS304 (EN-X5CrNi18-10)	95	Chain	Construction steel SS400
36	Lubricant	Turbine oil (ISO VG32)			
46	Air vent screw	Nylon			
52A	Upper bearing	6304ZZC3			
52B	Lower bearing	6309ZZC3			
53	Motor Protector 380/400/415V	50Hz KA314-HRXL00 (H.C)			
54	Shaft	SUS420J2 (EN-X30Cr13)			
55	Rotor	.			