

Data sheet 100B42.2-52

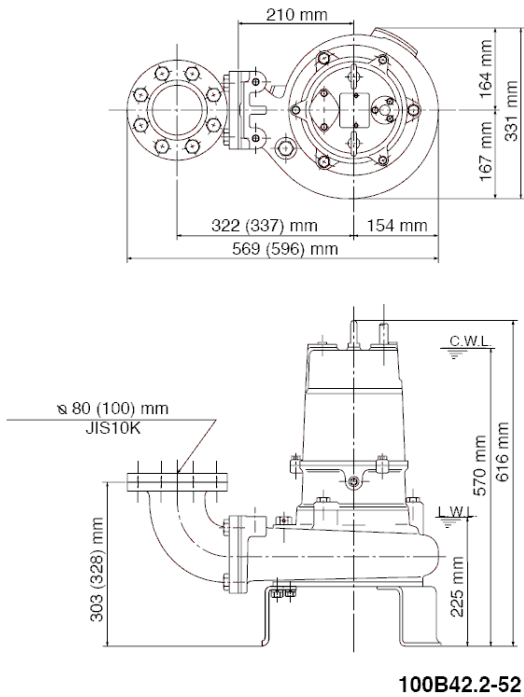

CWL: Continuous running water level
LWL: Lowest running water level

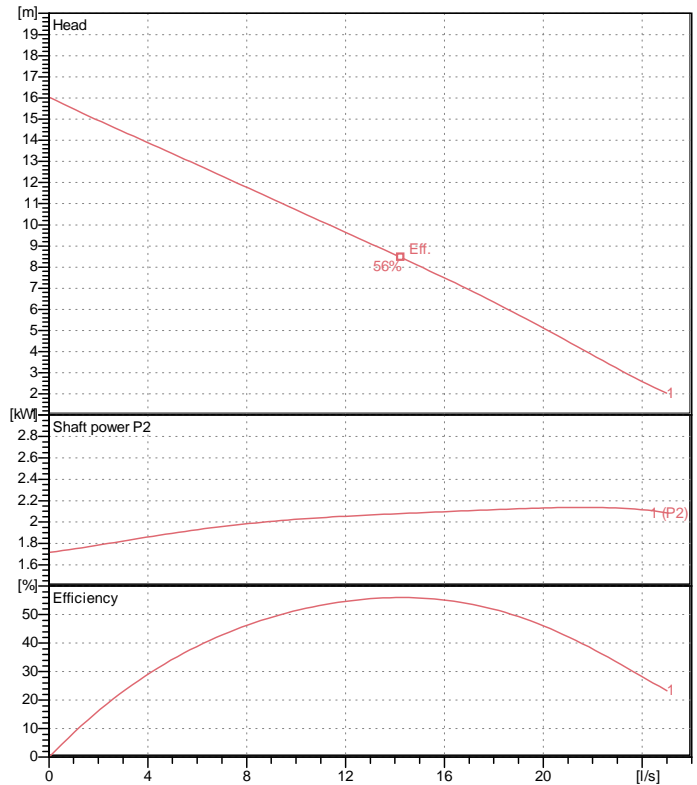

Specification

Electric submersible pump
Degree of protection IP 68
Depth of submersion max. 15 m
Type of impeller Single channel impeller
Free passage 45 mm
Suitable for:
sewage water

Electric motor

Dry-type submersible induction motor
Insulation class E 4Poles 1420 1/min
Starting mode Directly
Rated voltage 400 V 50 Hz 3~
Power uptake 2.85 kW
Rated power 2.20 kW
Rated current 5 A
Start current 32.0 A

Cable

10m H07RN-F 4Cx1,5mm²

Motor Protection

Circle thermal protector
(snap-action bi-metal device)

Shaft seal

Double inside mechanical seal in oil bath
additional lubrication by oil lifting device

Primary seal
Silicon carbide on silicon carbide
Secondary seal
Ceramic on carbon

Bearings

Shielded ball bearings, maintenance-free

Materials

Impeller	FC200 (EN-GJL-200)
Pump casing	FC200 (EN-GJL-200)
Suction cover	FC200 (EN-GJL-200)
Motor Frame	FC200 (EN-GJL-200)
Shaft	SUS420J2 (EN-X30Cr13)

Discharge size

4" (100mm) JIS 10K screwed-in mating flange
guide rail fitting optional

Weight

70 kg (dry weight of the pump only without cable)

Performance curve 100B42.2-52

Discharge port	4"
Head	16.0 m
Flow	25.0 l/s
Rated power	2.20 kW
Power input	2.85 kW
Phases	3~
Voltages	400 V
Frequency	50 Hz
Rated current	5 A
Starting current	32.00 A
Number of poles	4
Speed	1420 1/min
Starting mode	Directly
Insulation class	E

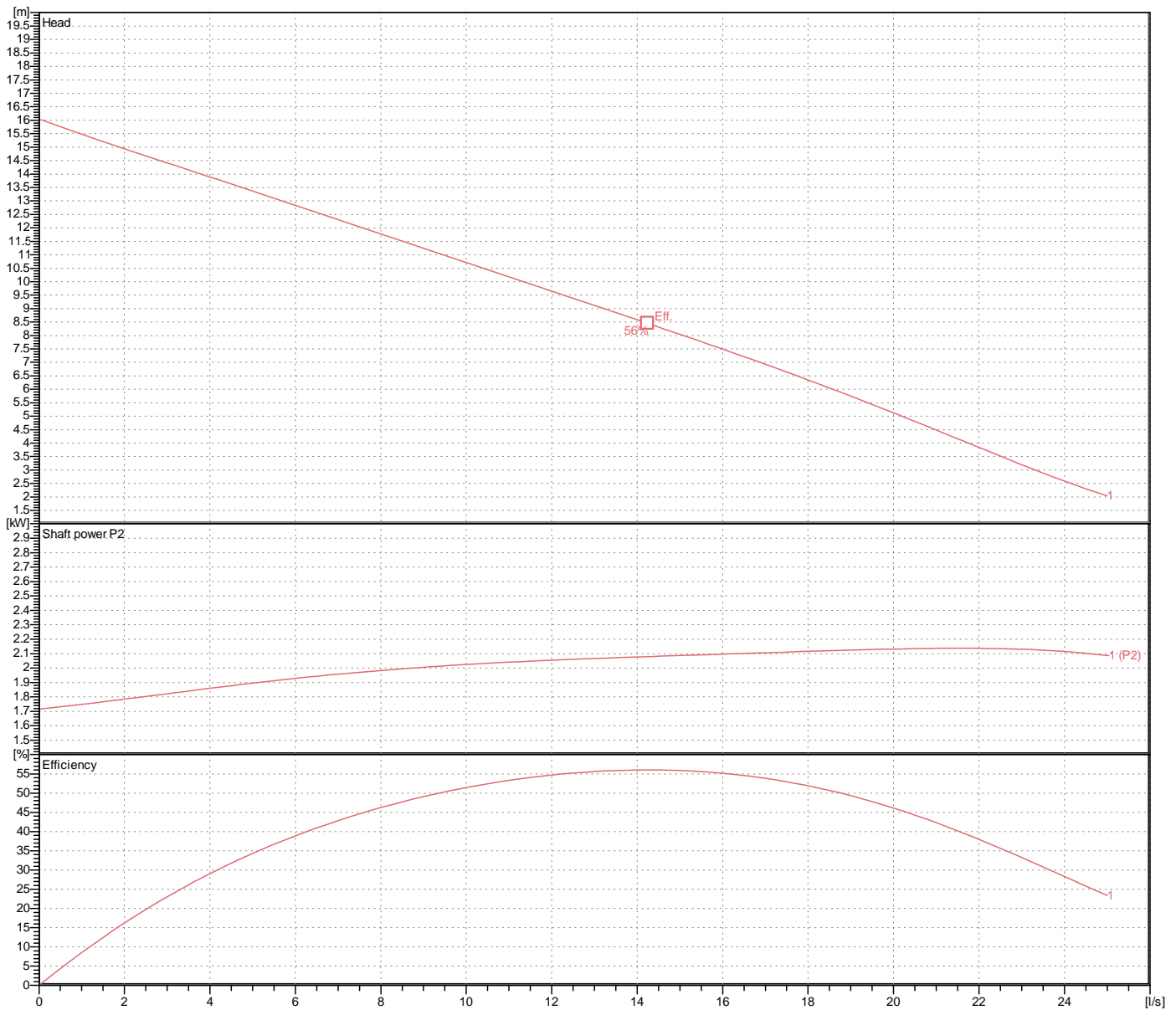

Dimensions 100B42.2-52

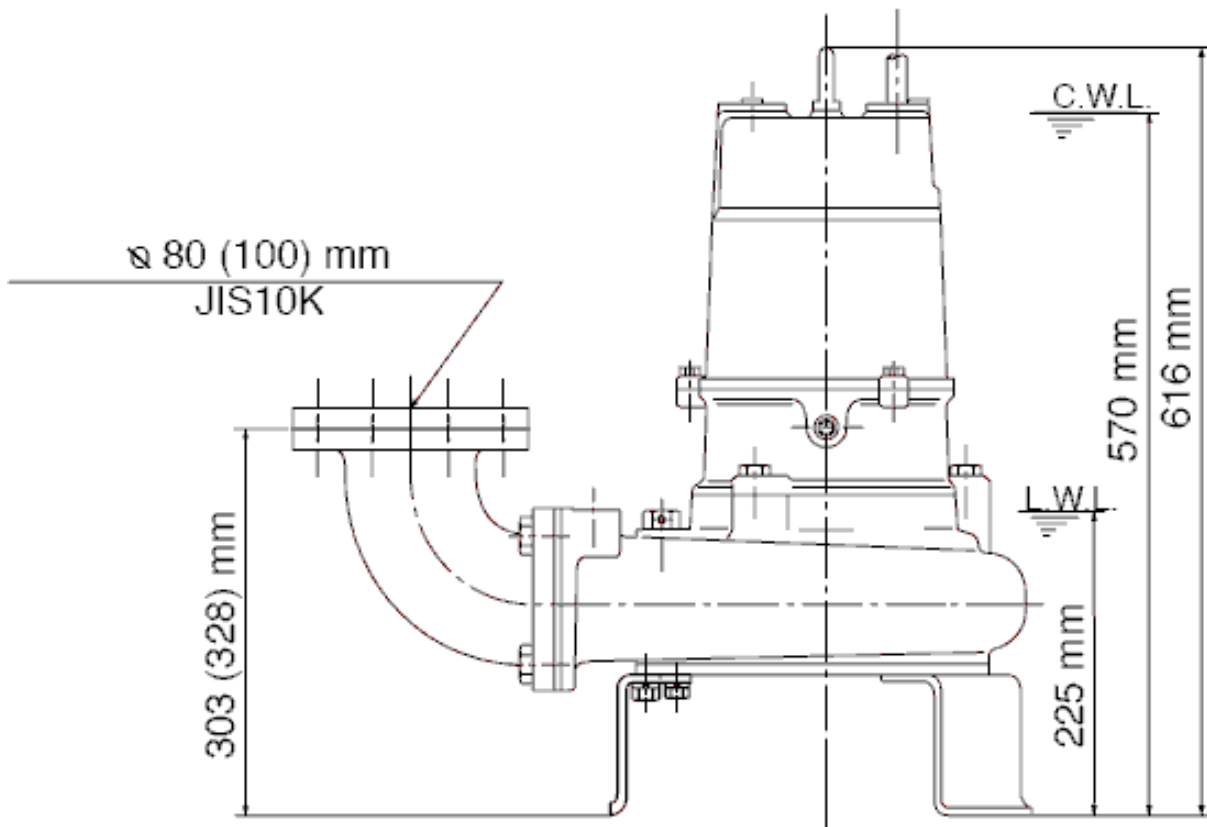
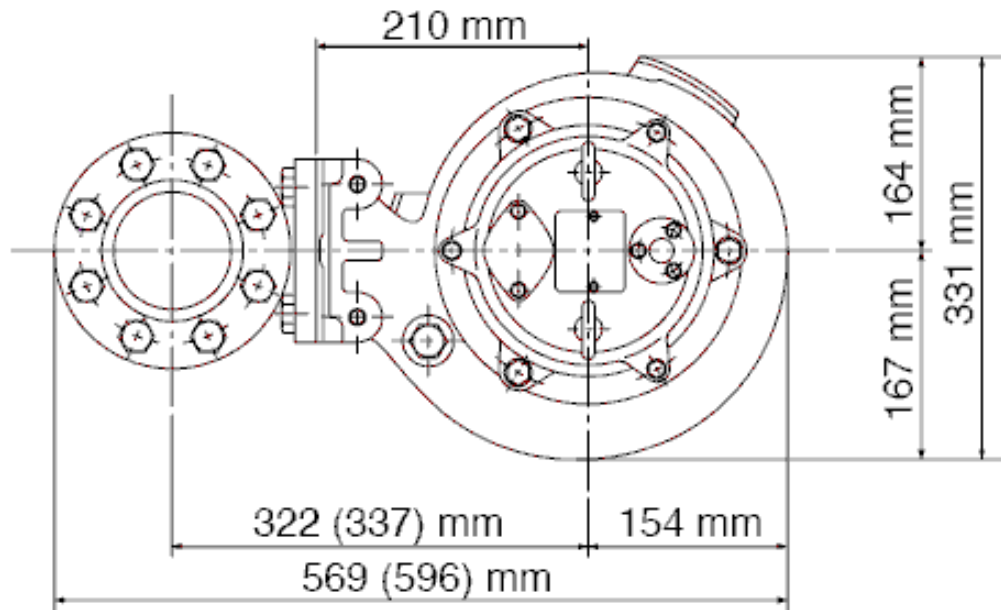

100B42.2-52

CWL: Continuous running water level
LWL: Lowest running water level

 **TSURUMI PUMP**

Tsurumi Europe GmbH
16.10.2018 V.18 / 1.10.2015

Heltorfer Str. 14 * 40472 Düsseldorf * Germany
Tel.: +49-211-4179373 sales@tsurumi.eu
Fax: +49-211-417937-480 www.tsurumi.eu

Sectional drawing 100B42.2-52

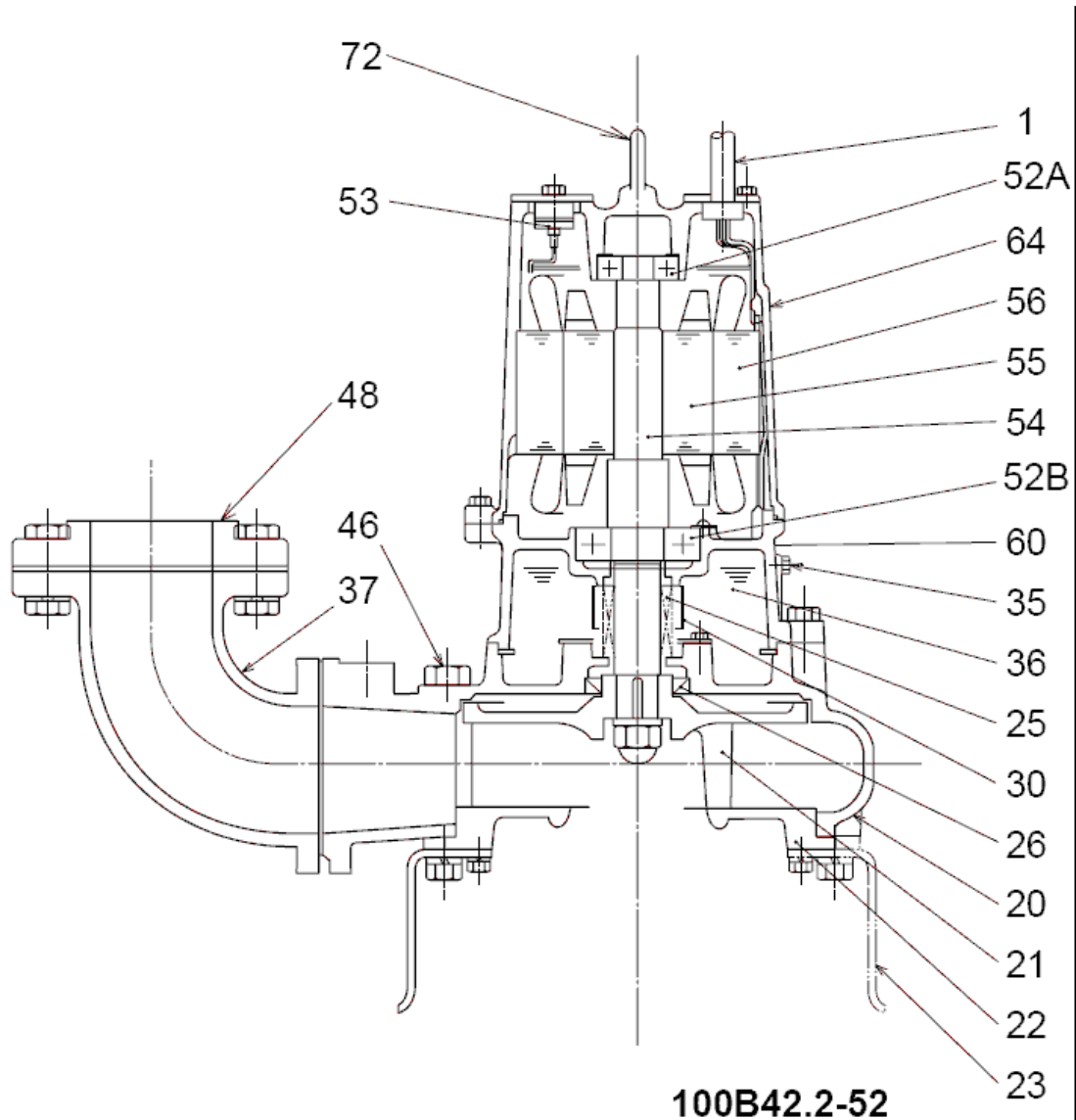

No.	Description	Remark	No.	Description	Remark
1	Cable	H07RN-F	54	Shaft	SUS420J2 (EN-X30Cr13)
20	Pump casing	FC200 (EN-GJL-200)	55	Rotor	.
21	Impeller	FC200 (EN-GJL-200)	56	Stator	.
22	Suction cover	FC200 (EN-GJL-200)	60	Bearing Housing	FC200 (EN-GJL-200)
23	Stand support (3x)	Construction steel SS400	64	Motor Frame	FC200 (EN-GJL-200)
25	Mechanical seal	H-30A	72	Eye screw (2x)	SUS304 (EN-X5CrNi18-10)
26	Oil seal	TC456812			
30	Oil distributor	Plastic			
35	Oil screw	SUS304 (EN-X5CrNi18-10)			
36	Lubricant	Turbine oil (ISO VG32)			
37	Discharge bend	FC200 (EN-GJL-200)			
46	Air vent screw	Nylon			
48	Screwed Flange	FC200 (EN-GJL-200)			
52A	Upper bearing	6304ZZC3			
52B	Lower bearing	6307ZZC3			
53	Motor Protector 380/400/415V-50Hz KA314-HRXL00 (H.C)				