

Data sheet 80U23.7-54

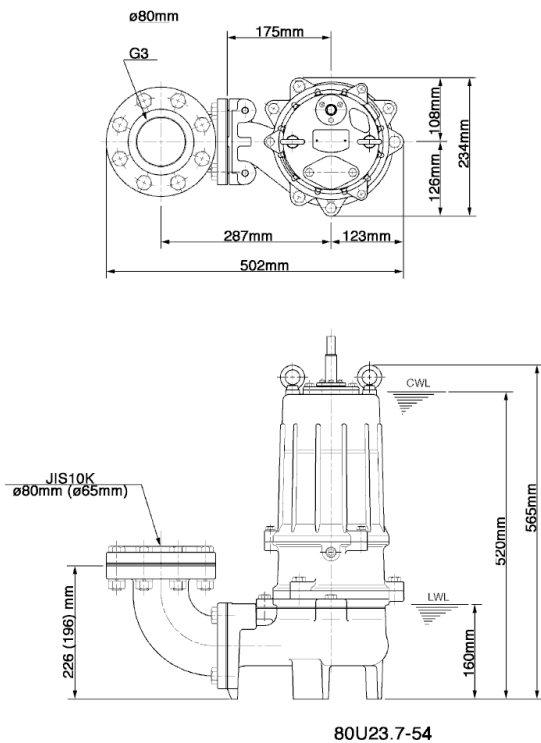

80U23.7-54

CWL: Continuous running water level
LWL: Lowest running water level

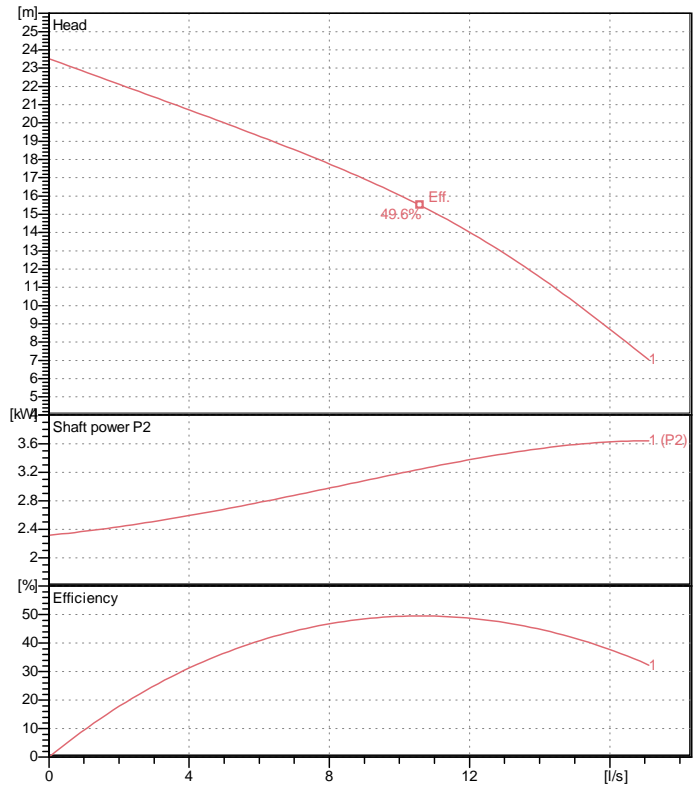

Specification

Electric submersible pump
Degree of protection IP 68
Depth of submersion max. 15 m
Type of impeller Vortex impeller
Free passage 56 mm
Suitable for:
waste water and liquid carrying

Electric motor

Dry-type submersible induction motor
Insulation class F 2Poles 2850 1/min
Starting mode Directly
Rated voltage 400 V 50 Hz 3~
Power uptake 4.85 kW
Rated power 3.70 kW
Rated current 7.7 A
Start current 58.0 A

Cable

10m H07RN-F 4Cx1,5mm²

Motor Protection

Circle thermal protector
(snap-action bi-metal device)

Shaft seal

Double inside mechanical seal in oil bath
additional lubrication by oil lifting device

Primary seal
Silicon carbide on ceramic
Secondary seal
Ceramic on carbon

Bearings

Shielded ball bearings, maintenance-free

Materials

Impeller FC200 (EN-GJL-200)
Pump casing FC200 (EN-GJL-200)
Motor Frame FC150 (EN-GJL-150)
Shaft SUS420J2 (EN-X30Cr13)

Discharge size

80mm screwed-in mating flange
guide rail fitting optional

Weight

62 kg (dry weight of the pump only without cable)

Performance curve

80U23.7-54

Discharge port	3"
Head	23.5 m
Flow	17.1 l/s
Rated power	3.70 kW
Power input	4.85 kW
Phases	3~
Voltages	400 V
Frequency	50 Hz
Rated current	7.7 A
Starting current	57.98 A
Number of poles	2
Speed	2850 1/min
Starting mode	Directly
Insulation class	F

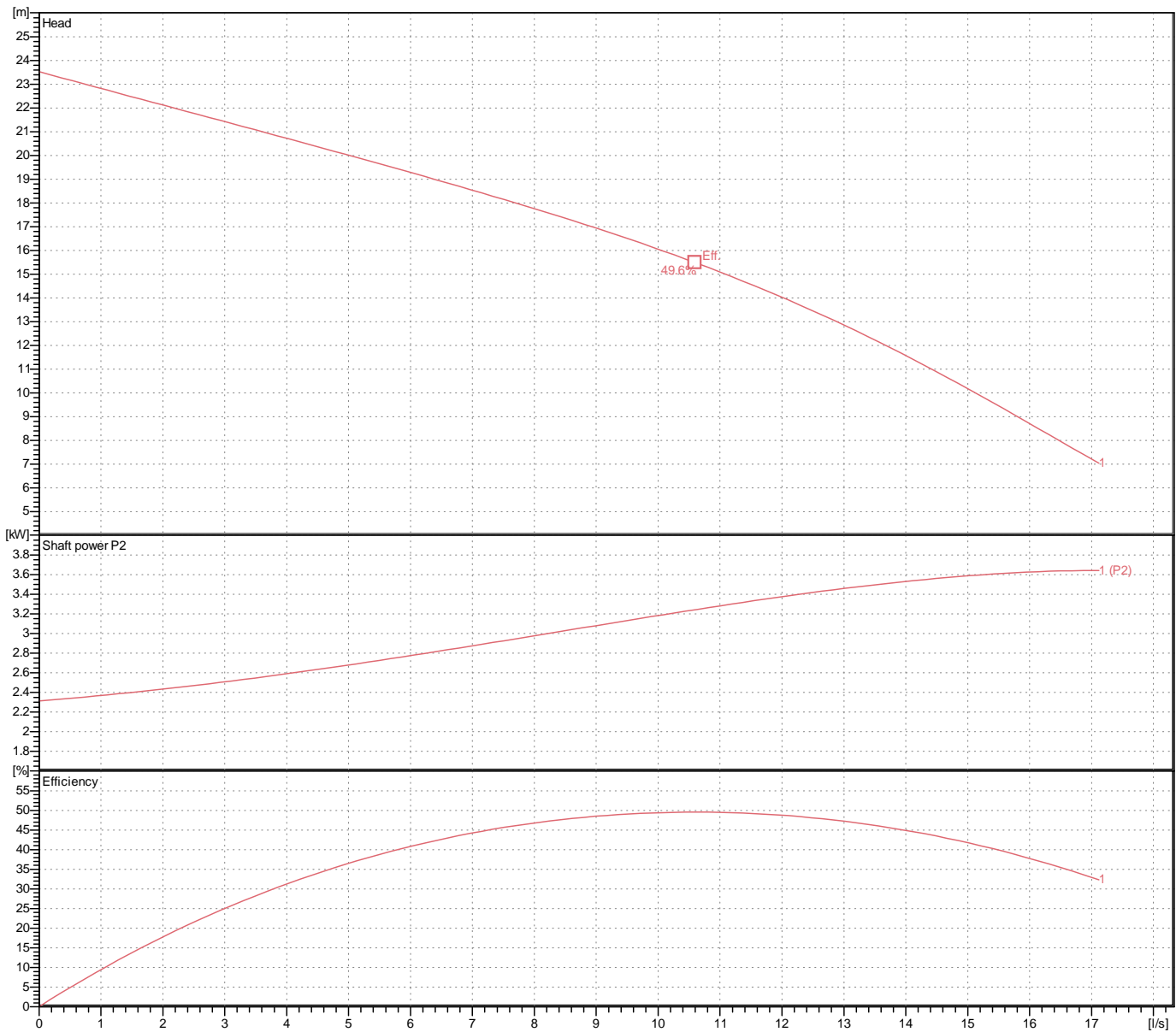

Dimensions

80U23.7-54

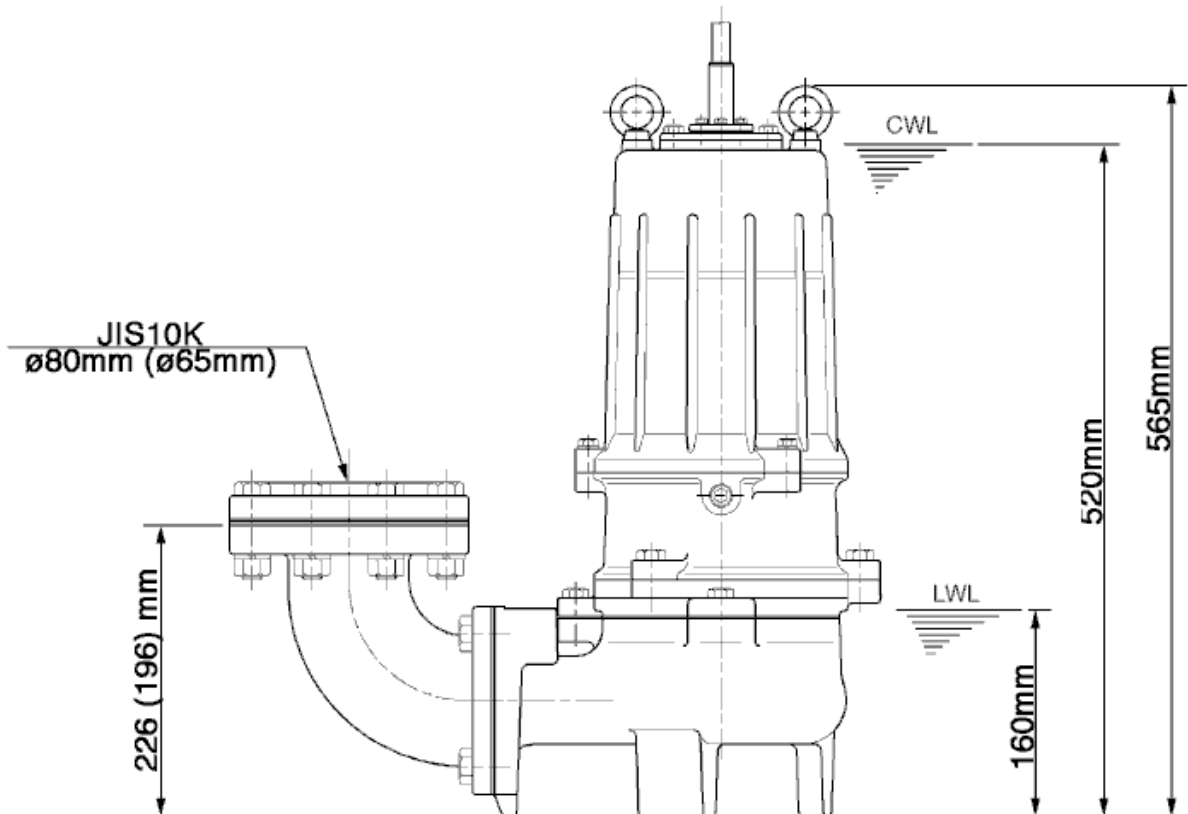
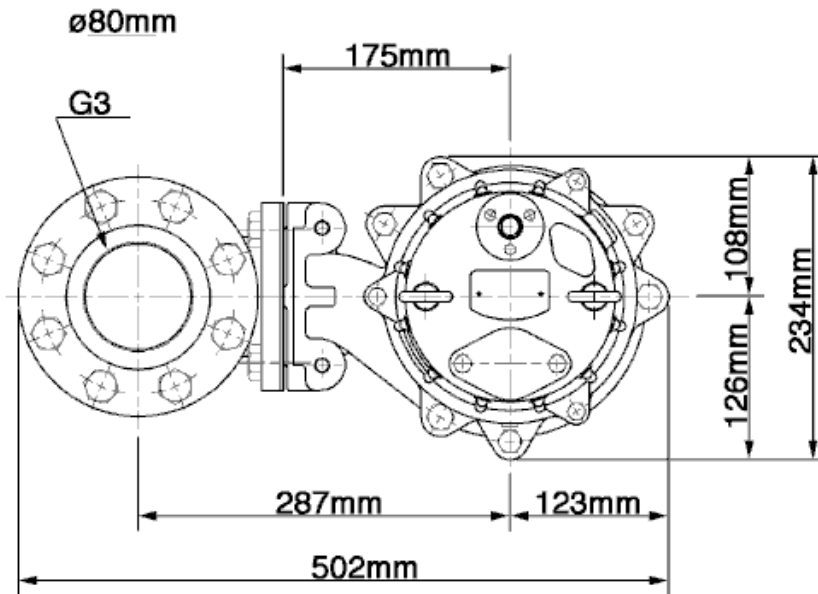

80U23.7-54

CWL: Continuous running water level
LWL: Lowest running water level

 **TSURUMI PUMP**

Tsurumi Europe GmbH
21.01.2019 V.18 / 1.10.2015

Heltorfer Str. 14 * 40472 Düsseldorf * Germany
Tel.: +49-211-4179373 sales@tsurumi.eu
Fax: +49-211-417937-480 www.tsurumi.eu

Sectional drawing 80U23.7-54

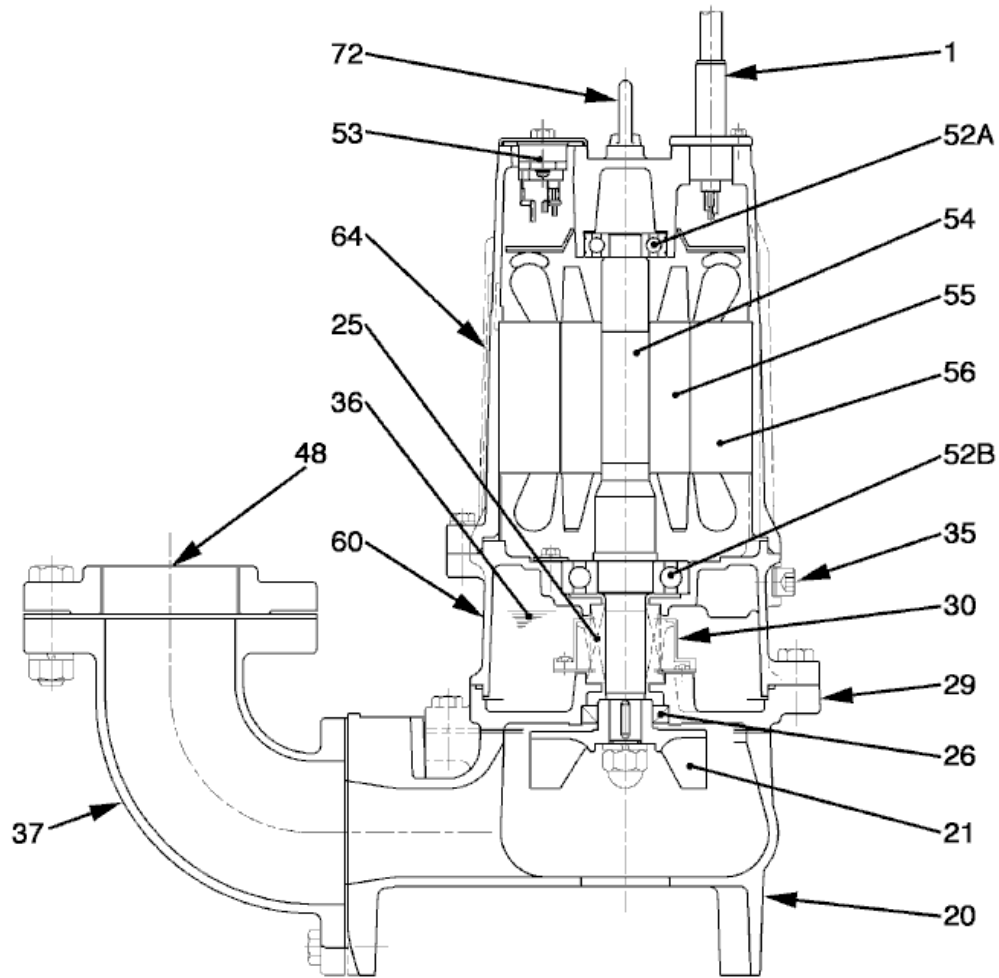

80U23.7-54

No.	Description	Remark	No.	Description	Remark
1	Cable	H07RN-F	56	Stator	.
20	Pump casing	FC200 (EN-GJL-200)	60	Bearing Housing	FC150 (EN-GJL-150)
21	Impeller	FC200 (EN-GJL-200)	64	Motor Frame	FC150 (EN-GJL-150)
25	Mechanical seal	H-25A	72	Eye screw (2x)	SUS304 (EN-X5CrNi18-10)
26	Oil seal	DD-355511			
29	Oil casing	FC200 (EN-GJL-200)			
30	Oil distributor	Plastic			
35	Oil screw	SUS304 (EN-X5CrNi18-10)			
36	Lubricant	Turbine oil (ISO VG32)			
37	Discharge bend	FC200 (EN-GJL-200)			
48	Screwed Flange	FC200 (EN-GJL-200)			
52A	Upper bearing	6304ZZC3			
52B	Lower bearing	6307ZZC3			
53	Motor Protector 380/400/415V	50Hz KA314-HRXL00 (H.C)			
54	Shaft	SUS420J2 (EN-X30Cr13)			
55	Rotor	.			