

80C25.5-CR-51

Kontroll-Nr. --

2018-10-17 V.18 / 1.10.2015

80C25.5-CR-51			
Item	Item no.	Description	Quant.
1	001-TEG-09	Cable Set (20m) H07RN-F4C \times 2,5mm ² without stuffing box	1
1	M01-TEG-09	Cable Set (20m) NSSHÖU 4C \times 2,5mm ²	1
2	140-055-10	Hex.Bolt M8 \times 25 SUS304 (EN X5CrNi18-10)	4
3	142-163-21	Spring Washer M8 SUS316 (DIN 1.4401) Stainless Steel	4
4	070-107-18	Cable Clamp FC	1
5	140-035-27	Hex.Bolt M6 \times 20 SUS304 (EN X5CrNi18-10) Stainless Steel	2
6	006-126-14	Stuffing Box No.2 FC	1
7	008-136-13	Mould Cover KR2-1 CR	1
8	143-013-15	Pan Screw M4 \times 6 SWRM	1
9	142-160-31	Spring Washer M4 SWRH	1
10	009-122-19	Terminal R-3.5-4 CU	1
11	009-234-15	Compression type Terminal 220/230/240V-50Hz(EUR) TGV/B-3.5 CU	3
12	072-102-48	Eye Bolt M12 SS	2
13	140-078-19	Hex.Bolt M10 \times 35 SUS304 (EN X5CrNi18-10)	4
14	142-164-19	Spring Washer M10 SUS304 (EN X5CrNi18-10)	4
15	050-435-16	Motor Bracket FC	1
16	122-151-11	O-Ring G-205 (NBR)	1
17	142-197-11	Wave Washer #6305 SK-5	1
18	052-108-13	Bearing 6305ZZC3	1
19	122-244-12	O-Ring 61.4xd3.1 NBR	1
20	143-126-38	Pan Screw (w/Spring Washer/Plain Washer) M4 \times 12 SWRM	2
21	053-506-18	Motor Protector 380-420V-50HZ 380-460V-60HZ KA314-HMKL00 (B.C)	1
22	058-184-11	Lead Wire Protection Plate d90xd224x1.6t SPHC	1
23	055-001-55	Rotor	1
24	147-066-15	Impeller Key 10x8x22L SUS420 (EN X30Cr13)	1
25	056-000-16	Stator 380/400/415-50HZ	1
26	140-079-10	Hex.Bolt M10 \times 40 SUS304 (EN X5Cr18-10)	4
27	142-164-19	Spring Washer M10 SUS304 (EN X5CrNi18-10)	4
28	064-000-11	Motor Frame FC	1
29	122-151-11	O-Ring G-205 (NBR)	1
30	140-000-06	Hex.Bolt (w/Spring Washer/Plain Washer) M6 \times 12 SWCH	3
31	052-139-13	Bearing 6308ZZD2C3	1
32	140-100-11	Hex.Bolt M12 \times 45 SUS304 (EN X5Cr18-10)	4
33	142-165-10	Spring Washer M12 SUS304 (EN X5Cr18-10)	4
34	060-001-08	Bearing HousingHT1-2-5.5/7.5-S FC FC	1
35	121-247-12	Packing (Oil Plug) d12.3xd18x2t PE	1
36	035-113-18	Oil Plug M12 \times 14 SUS304 (EN X5Cr18-10)	1
37	025-195-13	Mechanical Seal H-35 SiC	1
38	143-070-23	Pan Screw M5 \times 6 SWRM	2
39	030-156-18	Oil Lifter H-35(A)(T) Resin	1
40	143-070-10	Pan Screw M5 \times 6 SWRM	3
41	030-150-12	Seal Stopper H-35(A)(T) SPCC	1
42	122-281-11	O-Ring 190xd3.1 NBR	1
43	046-107-13	Air Release Valve PT-1/2 Nylon	1
44	035-112-17	Oil Plug M8 \times 12 SUS304 (EN X5CrNi18-10) Stainless Steel	1
45	121-248-13	Packing d8.2xd13.5x2t PE	1
46	020-002-07	Pump Casing 80C25.5/2.75/211-CR-61 FC	1
47	026-114-11	Oil Seal TC-557812 NBR	1
48	040-113-14	Impeller Shim d32.5xd48x0.3t SUS304 (EN X5CrNi18-10)	1
49	021-007-50	Impeller (50Hz) 80C25.5-CR-51 HICRFC	1
50	142-131-17	Plain Washer M20 SUS304 (EN X5CrNi18-10) Stainless Steel	1
51	142-168-13	Spring Washer M20 SUS304 (EN X5CrNi18-10) Stainless Steel	1
52	141-009-12	Hex.Nut M20 SUS304 (EN X5CrNi18-10) Stainless Steel	1
53	120-121-16	Packing d204xd264x0.3t PE	1
54	022-001-46	Suction Cover 80C25.5/27.5-CR-61 HICRFC	1
55	142-165-10	Spring Washer M12 SUS304 (EN X5Cr18-10)	3
56	140-096-13	Hex.Bolt M12 \times 25 SUS304 (EN X5Cr18-10)	3
57	023-288-18	Pump Stand 55/110-CE2 FC	3
58	142-165-10	Spring Washer M12 SUS304 (EN X5Cr18-10)	3
59	140-096-13	Hex.Bolt M12 \times 25 SUS304 (EN X5Cr18-10)	3
60	142-165-10	Spring Washer M12 SUS304 (EN X5Cr18-10)	3
61	140-099-16	Hex.Bolt M12 \times 40 SUS304 (EN X5CrNi18-10)	3
62	140-130-36	Hex.Bolt M16 \times 70 SWRM	8
63	048-000-39	Screwed Flange JIS10Kx80mm(PT) Grey Iron Casting	1
64	121-105-33	Packing JIS10Kx80mm NR	1
65	037-169-15	Discharge Bend 80x80mm Grey Iron Casting	1
66	142-166-37	Spring Washer M16 SWRH	8
67	141-008-11	Hex.Nut M16 SUS304 (EN X5CrNi18-10)	8
68	140-124-11	Hex.Bolt M16 \times 40 SUS304 (EN X5Cr18-10)	4
69	121-152-19	Packing 145mm2(P.C.145) NBR	1
	173-000-59	Packing & O-Ring Set	1
	##oilVG32	ml Turbine Oil ISO VG32	2240

Exploded View 80C25.5-CR-51

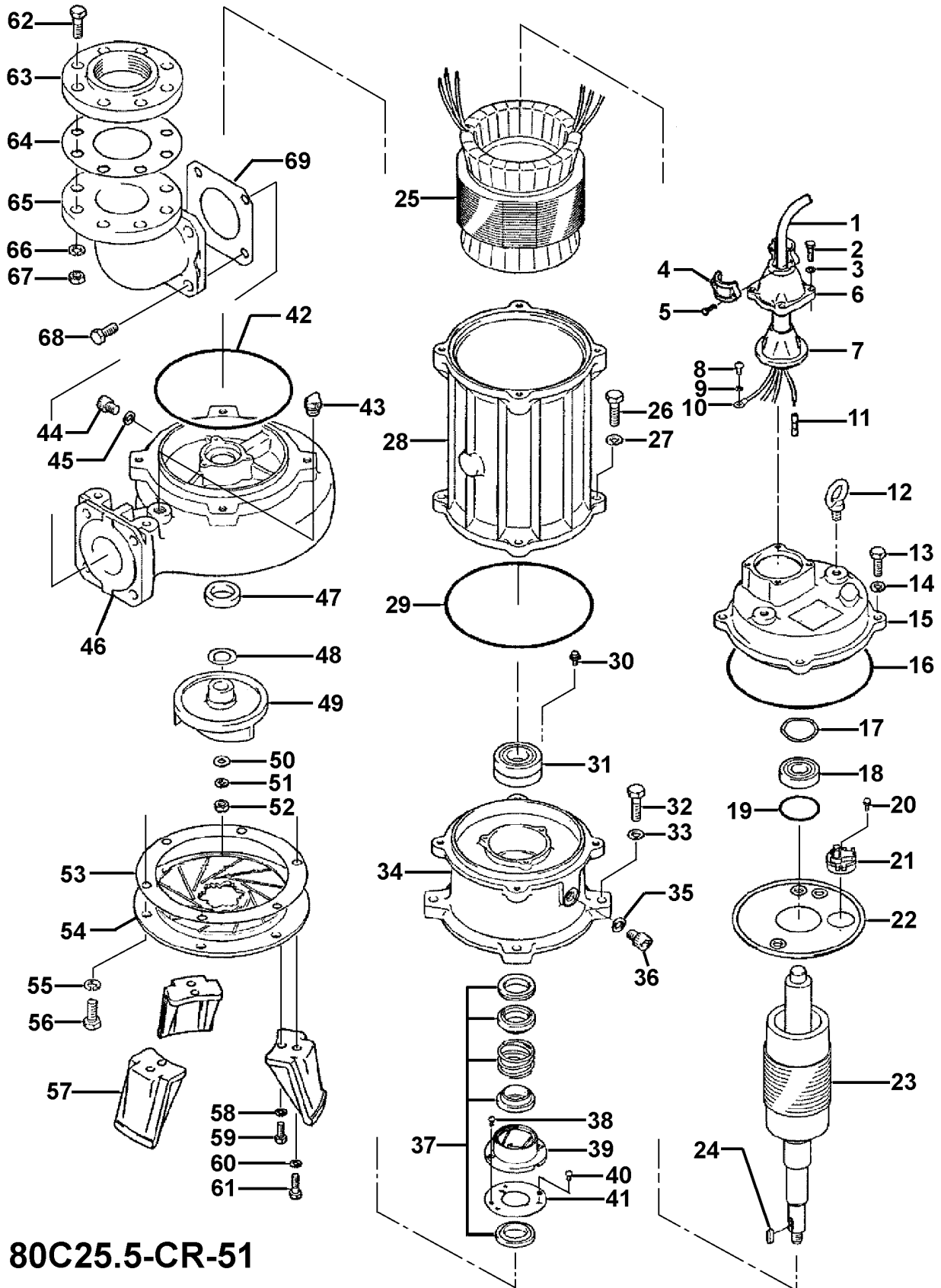

80C25.5-CR-51