

Data sheet 80C22.2-CR-51

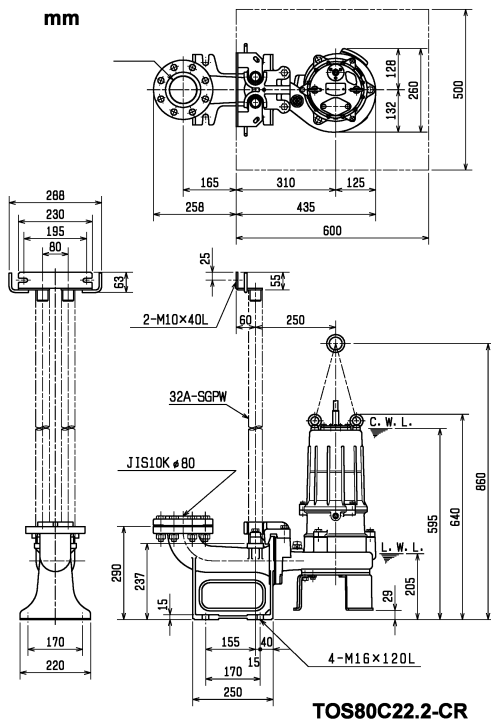

TOS80C22.2-CR

CWL: Continuous running water level
LWL: Lowest running water level

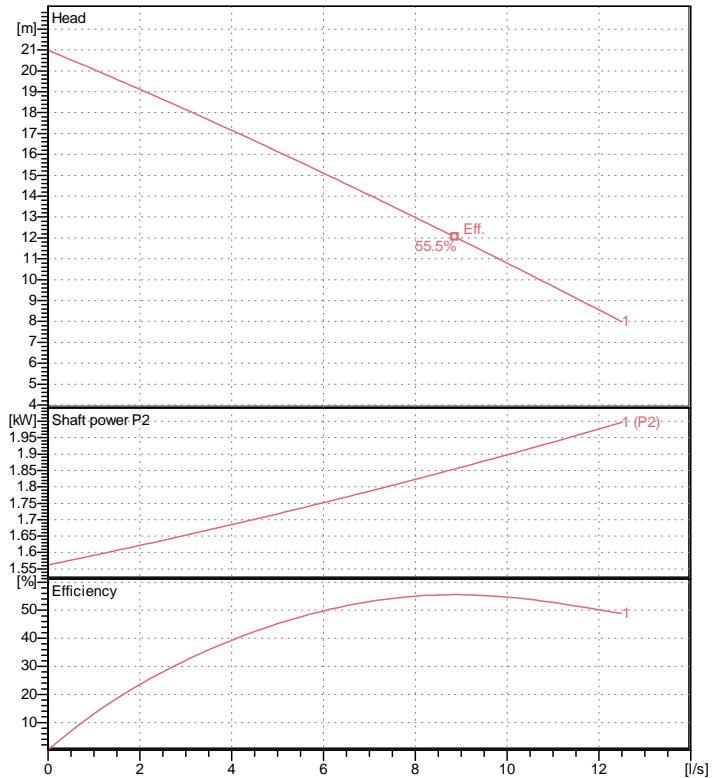

Specification

Electric submersible pump
Degree of protection IP 68
Depth of submersion max. 15 m
Type of impeller Dual channel impeller
Free passage 20 mm
Suitable for:
sewage water and liquids carrying solids

Electric motor

Dry-type submersible induction motor
Insulation class F 2Poles 2850 1/min
Starting mode Directly
Rated voltage 400 V 50 Hz 3~
Power uptake 3.10 kW
Rated power 2.20 kW
Rated current 5.2 A
Start current 58.2 A

Cable

10m H07RN-F 4Cx1,5mm²

Motor Protection

Circle thermal protector
(snap-action bi-metal device)

Shaft seal

Double inside mechanical seal in oil bath
additional lubrication by oil lifting device

Primary seal
Silicon carbide on silicon carbide
Secondary seal
Silicon carbide on silicon carbide

Bearings

Shielded ball bearings, maintenance-free

Materials

Impeller
Chromium Iron HiCrFC + Tungsten Carbide
Pump casing FC200 (EN-GJL-200)
Suction cover Chromium Iron HiCrFC
Motor Frame FC200 (EN-GJL-200)
Shaft SUS420J2 (EN-X30Cr13)

Discharge size

3" (80mm) special screwed-in mating flange
guide rail fitting optional

Weight

64 kg (dry weight of the pump only without cable)

Performance curve 80C22.2-CR-51

Discharge port	3"
Head	21.0 m
Flow	12.5 l/s
Rated power	2.20 kW
Power input	3.10 kW
Phases	3~
Voltages	400 V
Frequency	50 Hz
Rated current	5.2 A
Starting current	58.24 A
Number of poles	2
Speed	2850 1/min
Starting mode	Directly
Insulation class	F

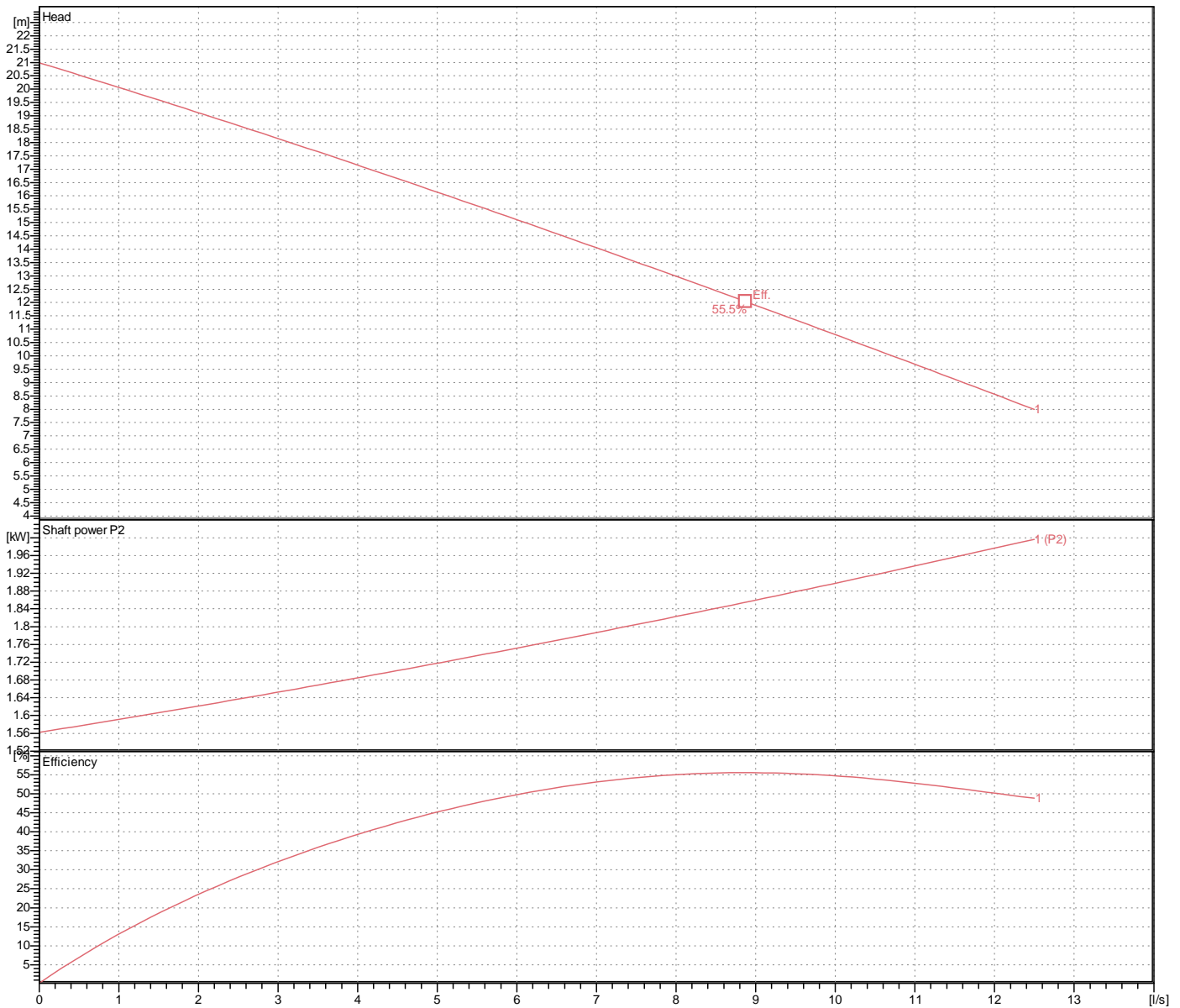

Sectional drawing TOS80C22.2-CR-51

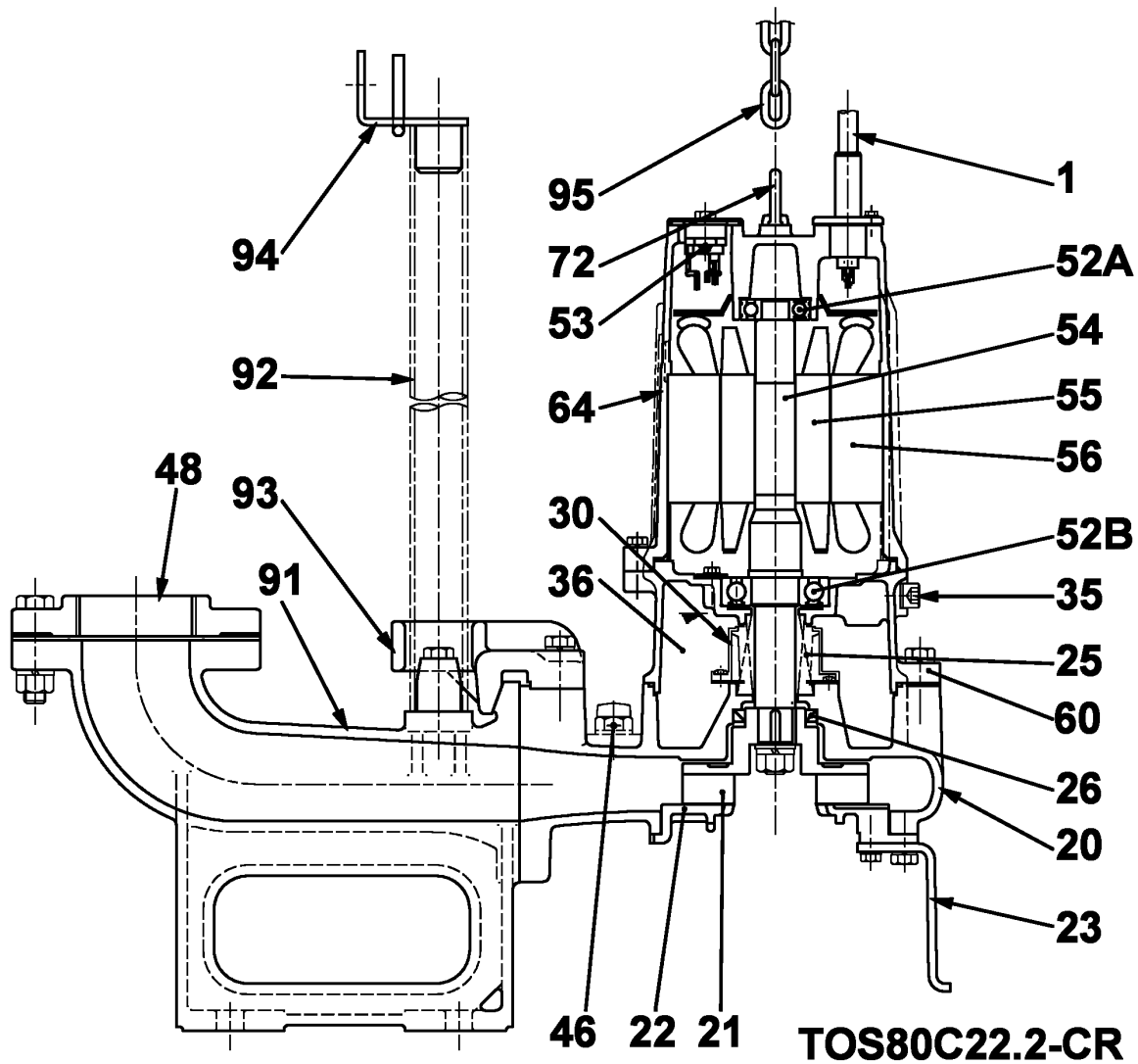

No.	Description	Remark	No.	Description	Remark
1	Cable	H07RN-F	55	Rotor	.
20	Pump casing	FC200 (EN-GJL-200)	56	Stator	.
21	Impeller	Chromium Iron HiCrFC + Tungsten Carbide	60	Bearing Housing	FC200 (EN-GJL-200)
22	Suction cover	Chromium Iron HiCrFC	64	Motor Frame	FC200 (EN-GJL-200)
23	Stand support (3x)	Construction steel SS400	72	Eye screw (2x)	SUS304 (EN-X5CrNi18-10)
25	Mechanical seal	H-30A	91	duck foot bend	FC200 (EN-GJL-200)
26	Oil seal	TC45629	92	Guide pipe (option) (2x)	electroplated steel pipe
30	Oil distributor	Plastic	93	guide support	FCD45 (EN-GJS-450-10)
35	Oil screw	SUS304 (EN-X5CrNi18-10)	94	Guide pipe holder	SUS304 (EN-X5CrNi18-10)
36	Lubricant	Turbine oil (ISO VG32)	95	Chain	Construction steel SS400
46	Air vent screw	Nylon			
48	Screwed Flange	FC200 (EN-GJL-200)			
52A	Upper bearing	6304ZZC3			
52B	Lower bearing	6307ZZC3			
53	Motor Protector 380/400/415V	50Hz KA314-HRXL00 (H.C)			
54	Shaft	SUS420J2 (EN-X30Cr13)			