

Data sheet 80BZ41.5-52

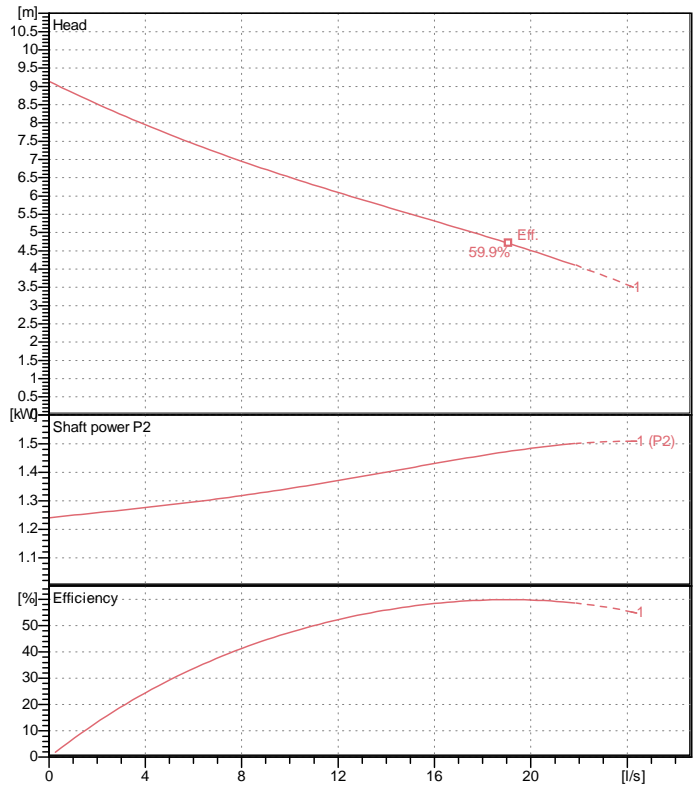
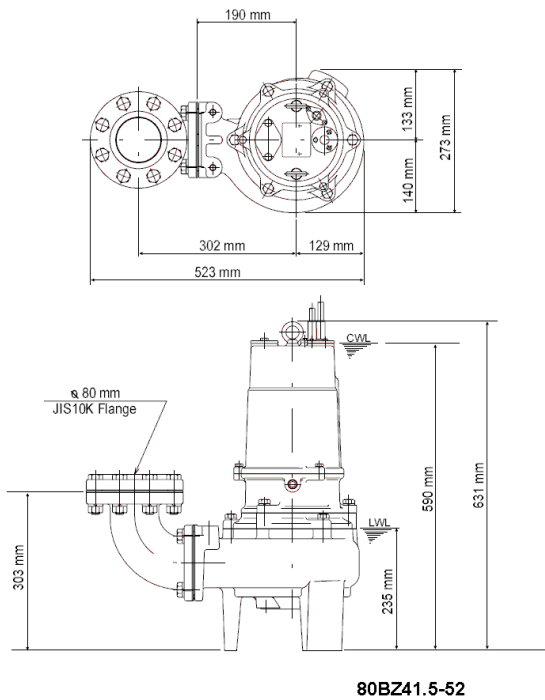

CWL: Continuous running water level
LWL: Lowest running water level

Specification

Electric submersible pump
Degree of protection IP 68
Depth of submersion max. 15 m
Type of impeller Single channel impeller
Free passage 80 mm
Suitable for:
sewage water

Electric motor

Dry-type submersible induction motor
Insulation class F 4 Poles 1420 1/min
Starting mode Directly
Rated voltage 400 V 50 Hz 3~
Power uptake 2.04 kW
Rated power 1.50 kW
Rated current 4 A
Start current 32.0 A

Cable

10m H07RN-F 4Cx1,5mm²

Motor Protection

Motor Protector
(snap-action bi-metal device)

Shaft seal

Double inside mechanical seal in oil bath
additional lubrication by oil lifting device

Primary seal
Silicon carbide on silicon carbide
Secondary seal
Silicon carbide on silicon carbide

Bearings

Shielded ball bearings, maintenance-free

Materials

Impeller	FC200 (EN-GJL-200)
Pump casing	FC200 (EN-GJL-200)
Motor Frame	FC150 (EN-GJL-150)
Shaft	SUS420J2 (EN-X30Cr13)

Discharge size

3" (80mm) special screwed-in mating flange
guide rail fitting optional

Weight

78 kg (dry weight of the pump only without cable)

Performance curve

80BZ41.5-52

Discharge port	3"
Head	9.1 m
Flow	21.8 l/s
Rated power	1.50 kW
Power input	2.04 kW
Phases	3~
Voltages	400 V
Frequency	50 Hz
Rated current	4 A
Starting current	32.00 A
Number of poles	4
Speed	1420 1/min
Starting mode	Directly
Insulation class	F

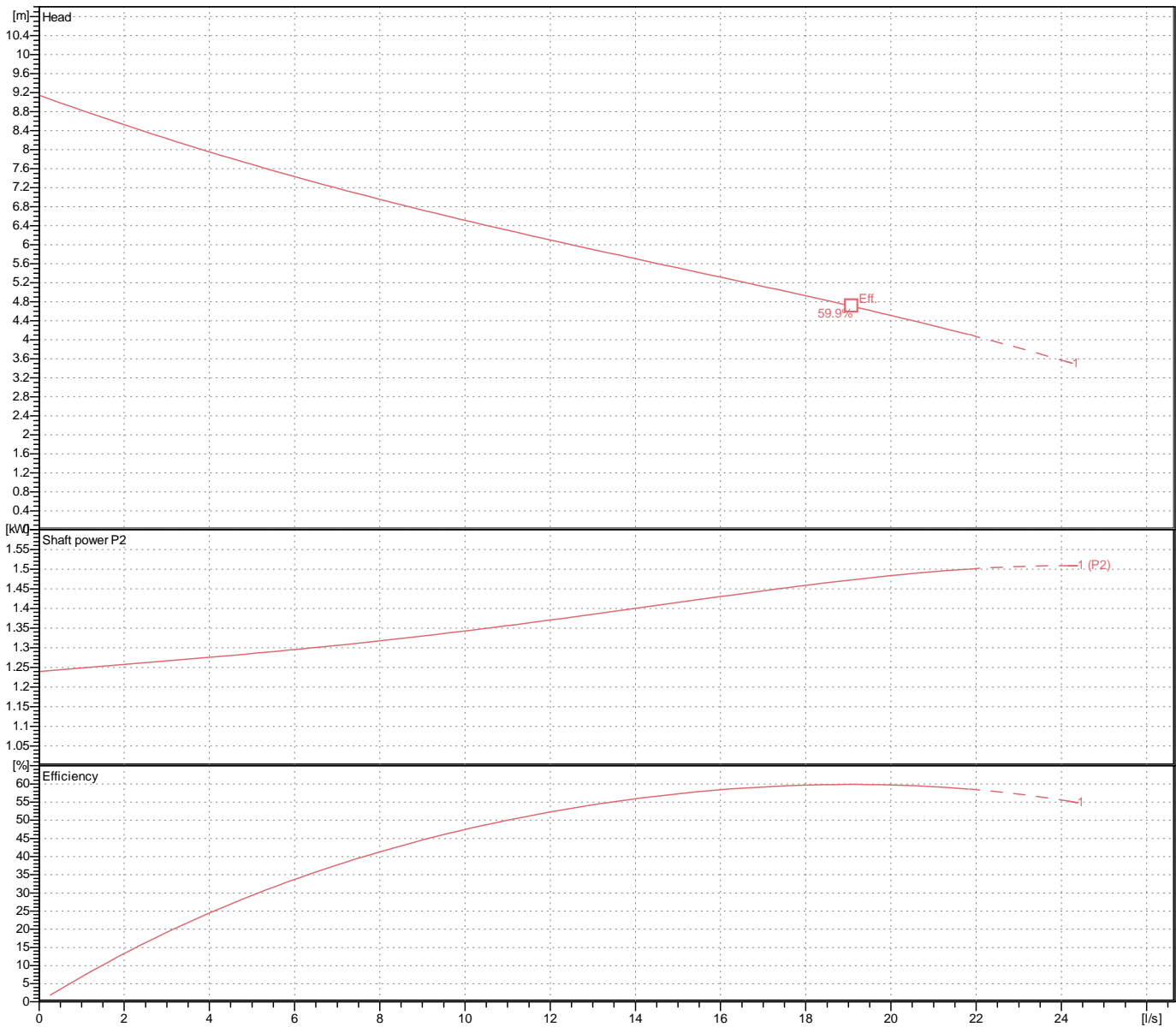

Dimensions 80BZ41.5-52

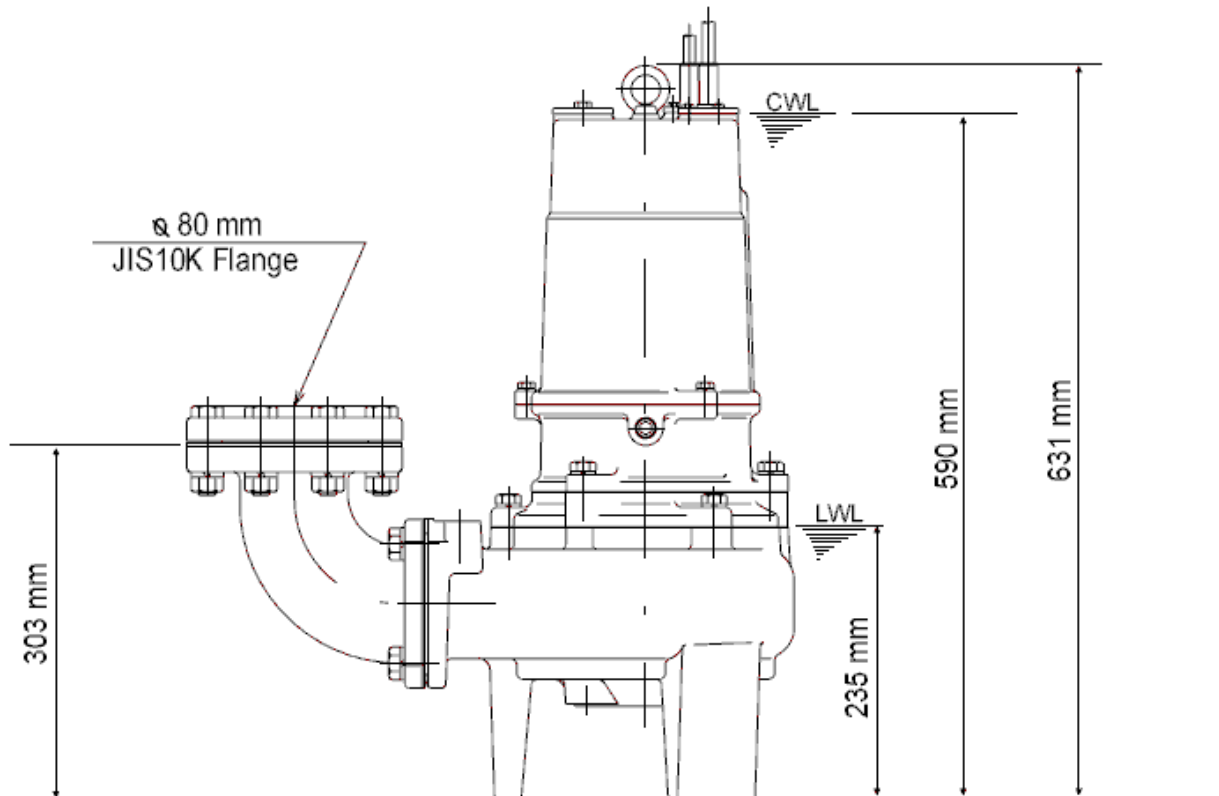
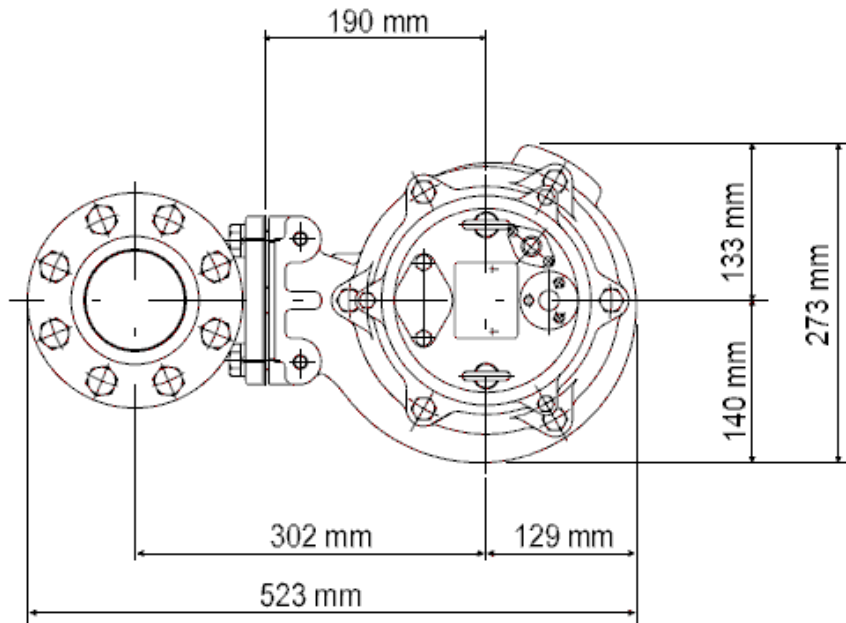

80BZ41.5-52

CWL: Continuous running water level
LWL: Lowest running water level

 **TSURUMI PUMP**

Tsurumi Europe GmbH
19.10.2018 V.18 / 1.10.2015

Helstorfer Str. 14 * 40472 Düsseldorf * Germany
Tel.: +49-211-4179373 sales@tsurumi.eu
Fax: +49-211-417937-480 www.tsurumi.eu

Sectional drawing 80BZ41.5-52

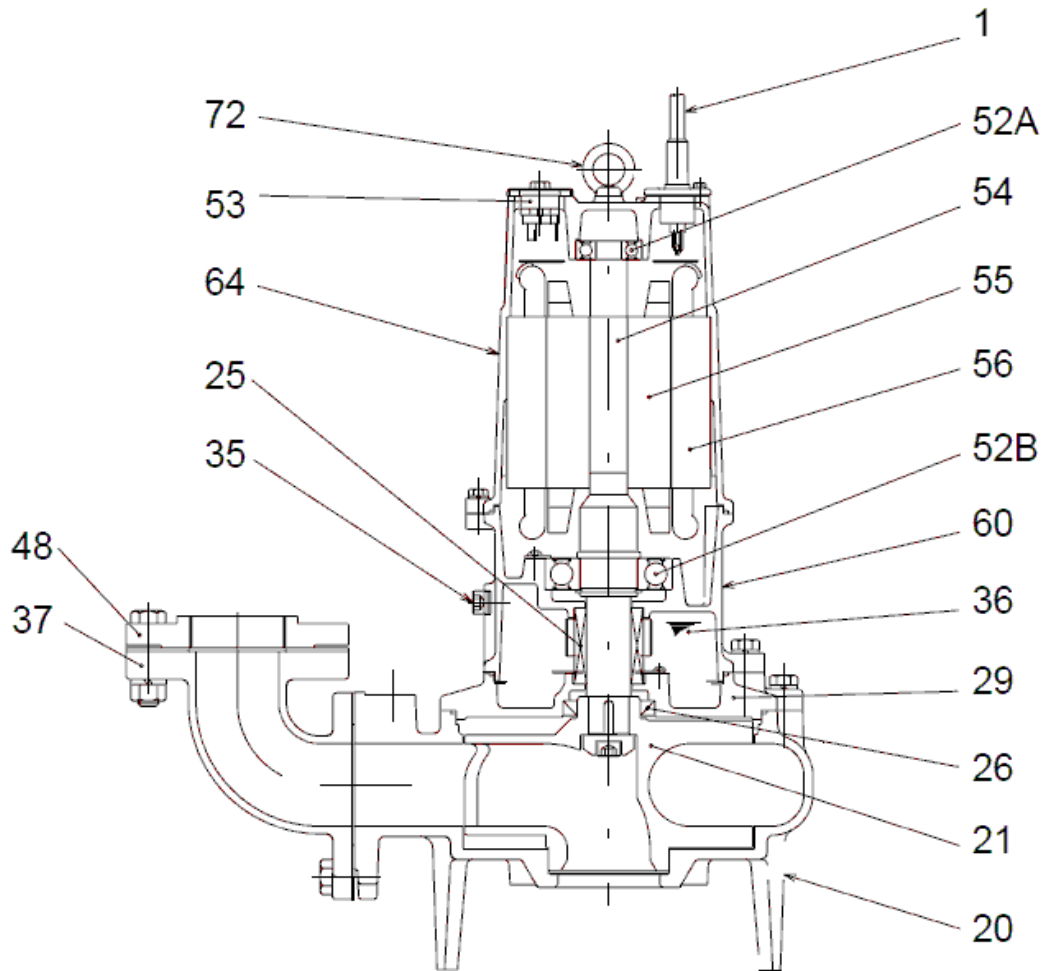

80BZ21.5-52

No.	Description	Remark	No.	Description	Remark
1	Cable	H07RN-F4Cx1,5SQ	56	Stator	.
1b	Cable Theroguard	VCT4Cx1,25SQ	60	Bearing Housing	FC150 (EN-GJL-150)
20	Pump casing	FC200 (EN-GJL-200)	64	Motor Frame	FC150 (EN-GJL-150)
21	Impeller	FC200 (EN-GJL-200)	72	Eye screw (2x)	SUS304 (EN-X5CrNi18-10)
25	Mechanical seal	H-30A			
26	Oil seal	TC456812			
29	Oil casing	FC200 (EN-GJL-200)			
35	Oil screw	SUS304 (EN-X5CrNi18-10)			
36	Lubricant	Turbine oil (ISO VG32)			
37	Discharge bend	FC200 (EN-GJL-200)			
48	Screwed Flange	FC200 (EN-GJL-200)			
52A	Upper bearing	6304ZZC3			
52B	Lower bearing	6307ZZC3			
53	Circle thermal protector (3x)	.			
54	Shaft	SUS420J2 (EN-X30Cr13)			
55	Rotor	.			