

Data sheet 50C2.75-53

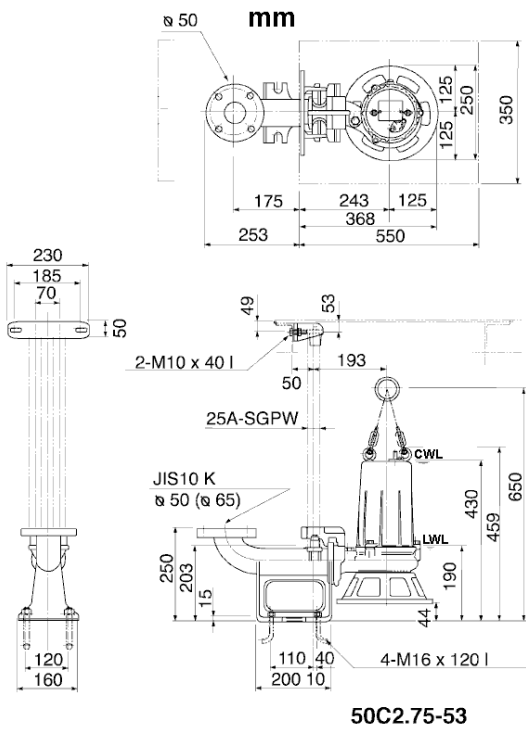

CWL: Continuous running water level
LWL: Lowest running water level

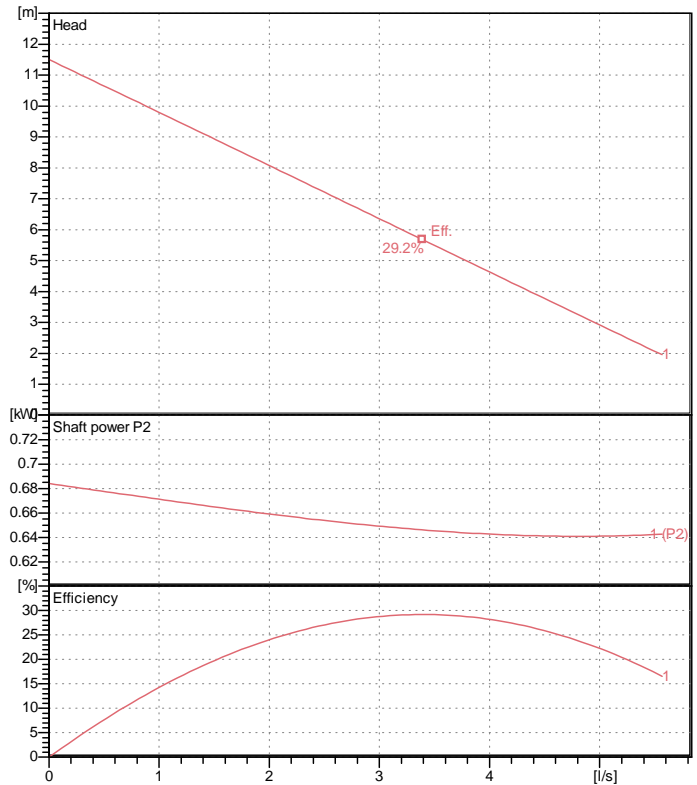

Specification

Electric submersible pump with cutter mechanism
Degree of protection IP 68
Depth of submersion max. 15 m
Type of impeller Single channel impeller
Free passage 21 mm
Suitable for:
sewage water and liquids carrying solids

Electric motor

Dry-type submersible induction motor
Insulation class E 2Poles 2810 1/min
Starting mode Directly
Rated voltage 400 V 50 Hz 3~
Power uptake 1.13 kW
Rated power 0.75 kW
Rated current 1.9 A
Start current 8.5 A

Cable

10m H07RN-F 4Cx1,5mm²

Motor Protection

Miniature protector in windings
(snap-action bi-metal device)

Shaft seal

Double inside mechanical seal in oil bath
additional lubrication by oil lifting device

Primary seal

Silicon carbide on silicon carbide

Secondary seal

Silicon carbide on silicon carbide

Bearings

Shielded ball bearings, maintenance-free

Materials

Impeller

FC20 (EN-GJL-200) + Tungsten carbide

Pump casing

FC200 (EN-GJL-200)

Suction cover

FCD700 (EN-GJS-700-2)

Motor Frame

FC200 (EN-GJL-200)

Shaft

SUS403 (EN-X6Cr13)

Discharge size

2" DIN-Flansch / JIS 10K-Flansch
guide rail fitting optional

Weight

23 kg (dry weight of the pump only without cable)

Performance curve

50C2.75-53

Discharge port	2"
Head	11.5 m
Flow	5.6 l/s
Rated power	0.75 kW
Power input	1.13 kW
Phases	3~
Voltages	400 V
Frequency	50 Hz
Rated current	1.9 A
Starting current	8.49 A
Number of poles	2
Speed	2810 1/min
Starting mode	Directly
Insulation class	E

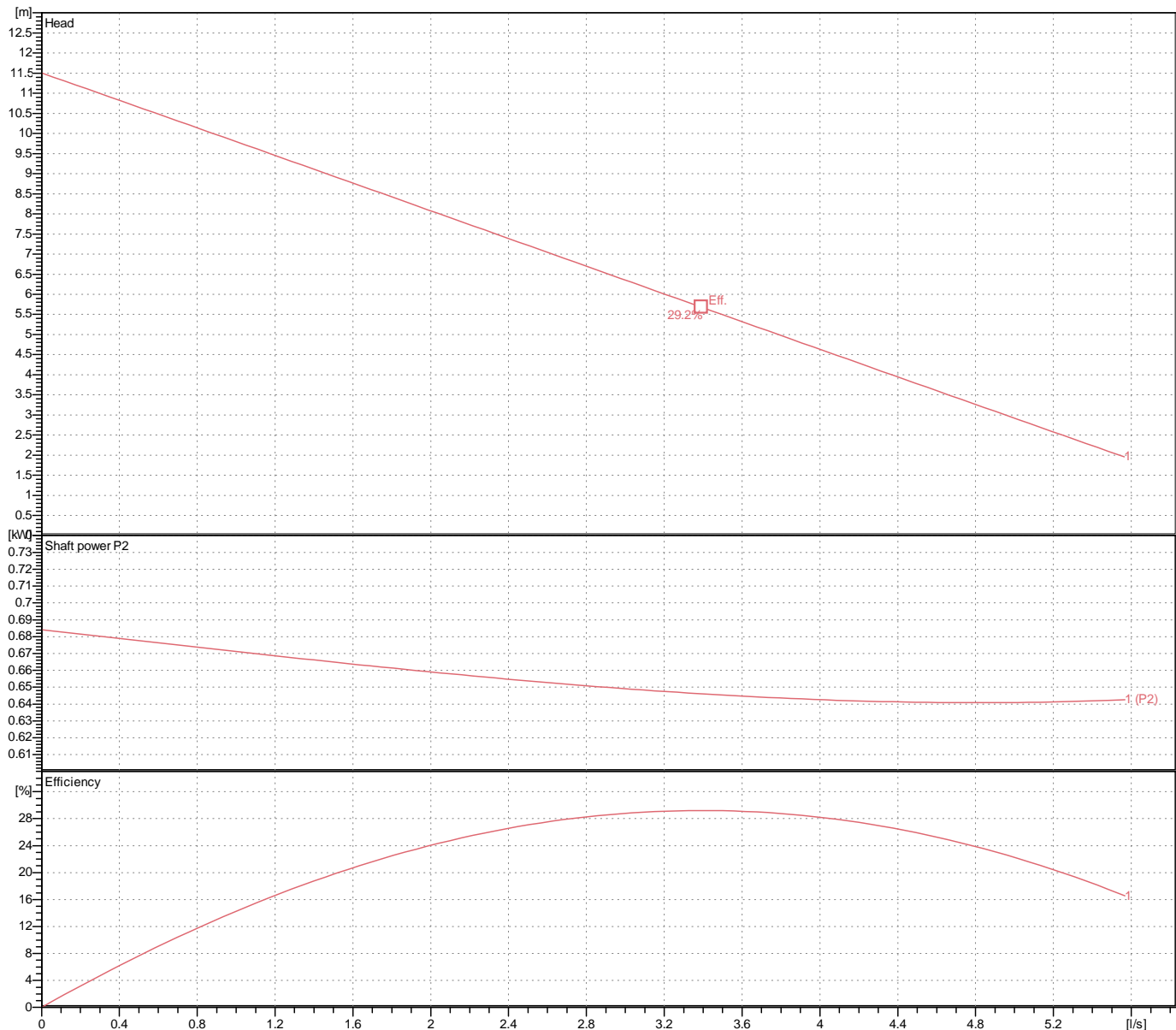

Dimensions TOS50C2.75-53

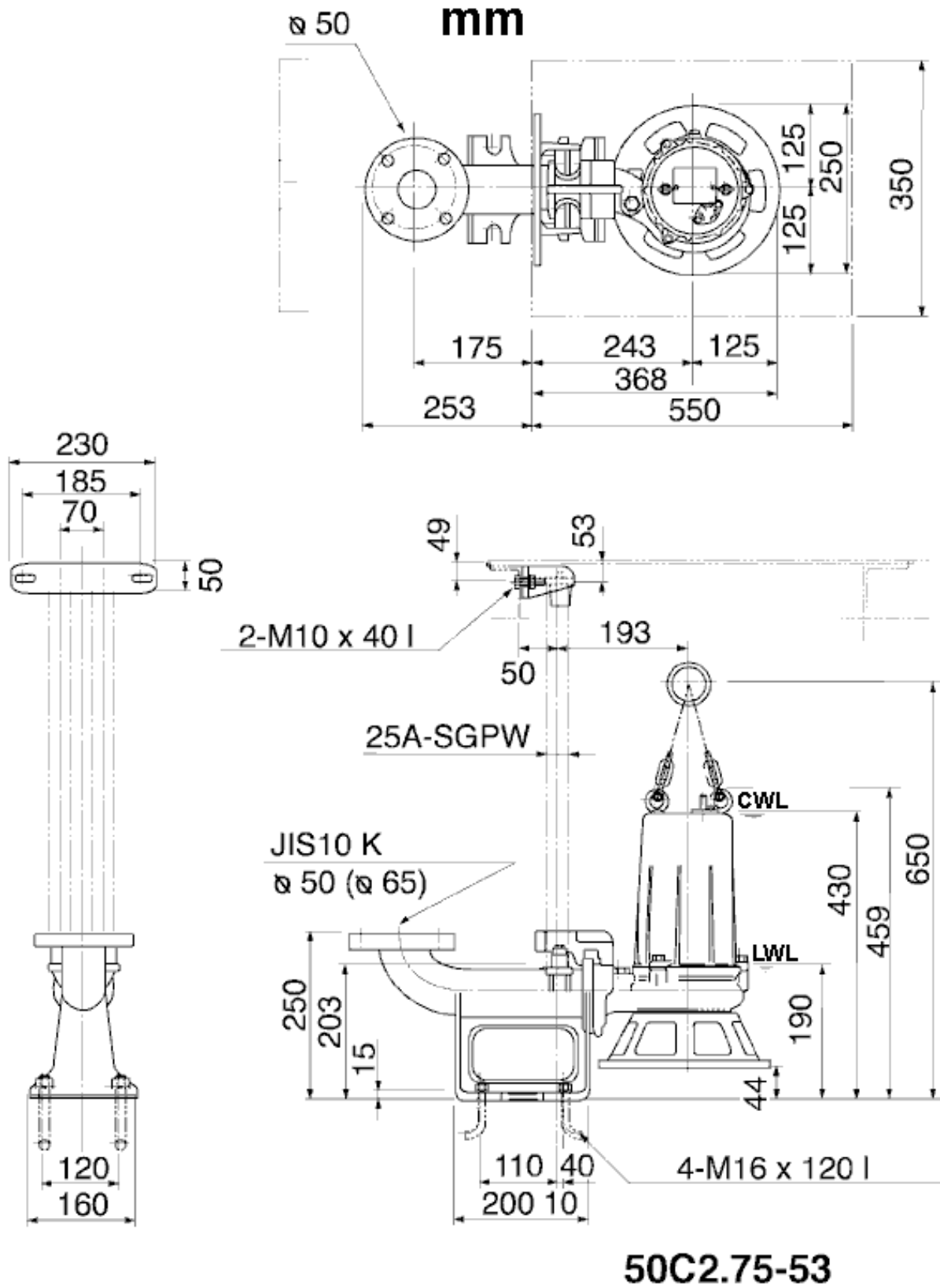

CWL: Continuous running water level
LWL: Lowest running water level

 **TSURUMI PUMP**

Tsurumi Europe GmbH
17.10.2018 V.18 / 1.10.2015

Heltorf Str. 14 * 40472 Düsseldorf * Germany
Tel.: +49-211-4179373 sales@tsurumi.eu
Fax: +49-211-417937-480 www.tsurumi.eu

Sectional drawing TOS50C2.75-53

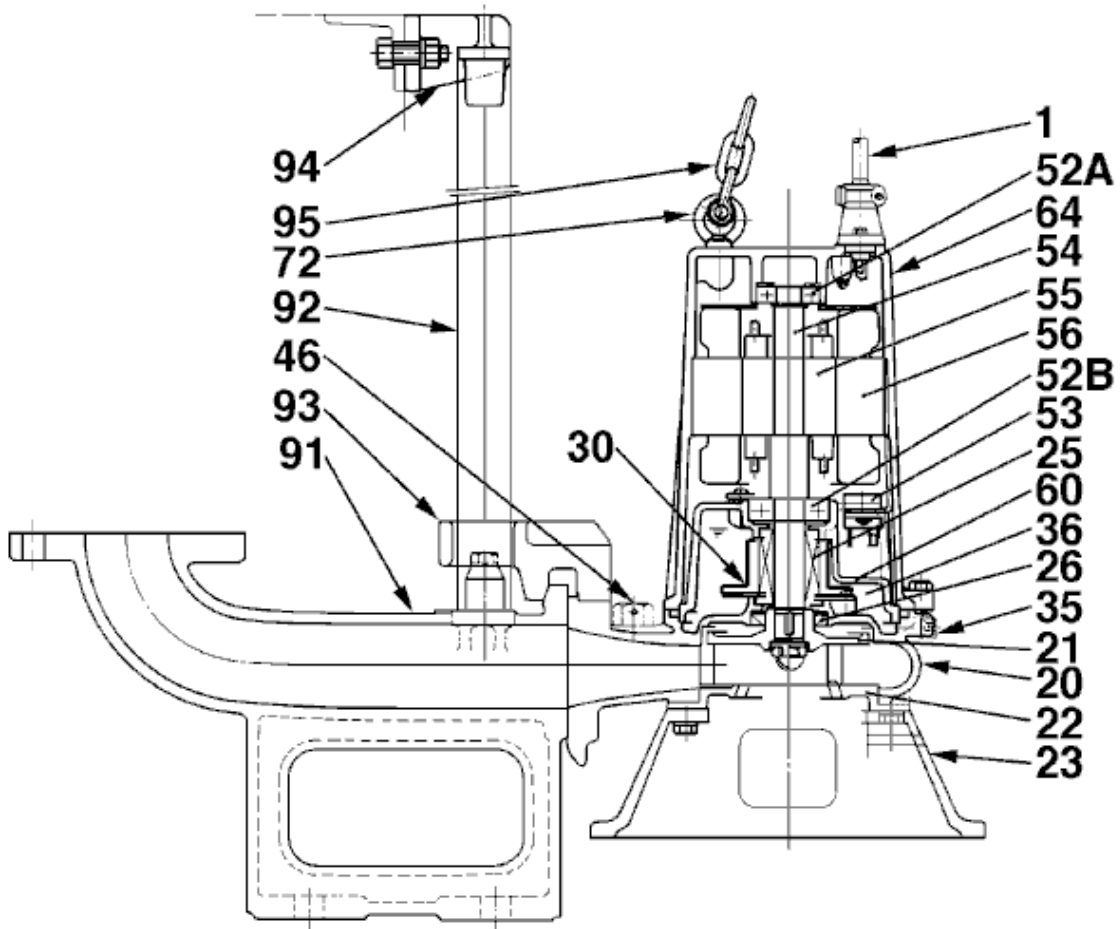

No.	Description	Remark	No.	Description	Remark
1	Cable	H07RN-F	56	Stator	.
20	Pump casing	FC200 (EN-GJL-200)	60	Bearing Housing	FC200 (EN-GJL-200)
21	Impeller	FC20 (EN-GJL-200) + Tungsten carbide	64	Motor Frame	FC200 (EN-GJL-200)
22	Suction cover	FCD700 (EN-GJS-700-2)	72	Eye screw (2x)	Construction steel SS400
23	Stand support	FCD45 (EN-GJS-450-10)	91	duck foot bend	FC200 (EN-GJL-200)
25	Mechanical seal	H-20A	92	Guide pipe (option) (2x)	electroplated steel pipe
26	Oil seal	TC32488	93	guide support	FCD45 (EN-GJS-450-10)
30	Oil distributor	Plastic	94	Guide pipe holder	FCD45 (EN-GJS-450-10)
35	Oil screw	SUS304 (EN-X5CrNi18-10)	95	Chain	Construction steel SS400
36	Lubricant	Turbine oil (ISO VG32)			
46	Air vent screw	Nylon			
52A	Upper bearing	6203ZZC3			
52B	Lower bearing	6304ZZC3			
53	Motor Protector 380/400/415V	50Hz KA314-HRXL00 (H.C)			
54	Shaft	SUS403 (EN-X6Cr13)			
55	Rotor	.			