

Data sheet 100C411-53

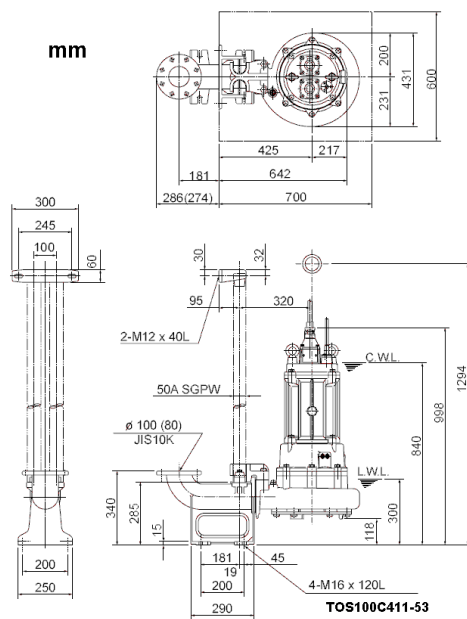

CWL: Continuous running water level
LWL: Lowest running water level

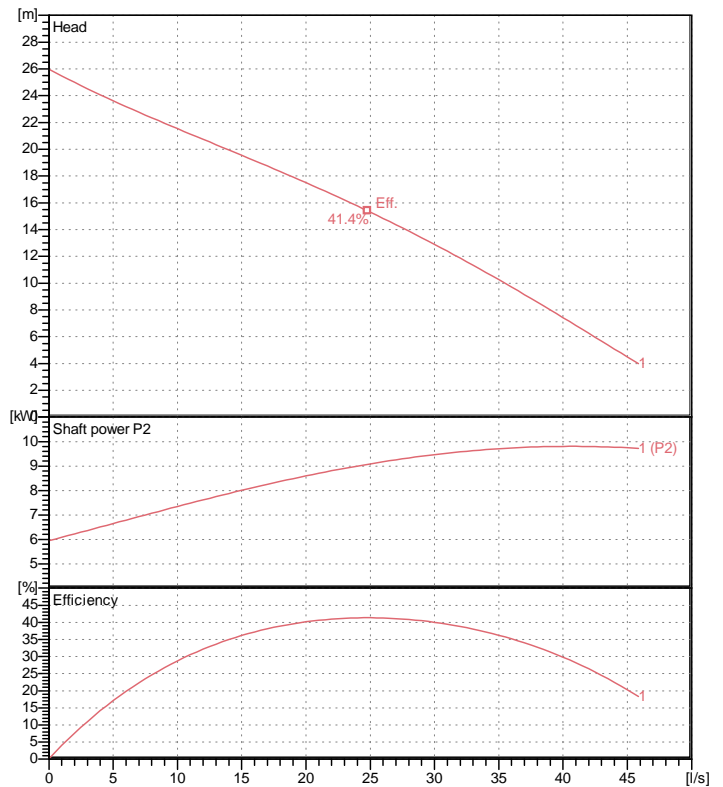

Specification

Electric submersible pump with cutter mechanism
Degree of protection IP 68
Depth of submersion max. 20 m
Type of impeller Single channel impeller
Free passage 50 mm
Suitable for:
sewage water and liquids carrying solids

Electric motor

Dry-type submersible induction motor
Insulation class F 4Poles 1445 1/min
Starting mode Star-delta
Rated voltage 400 V 50 Hz 3~
Power uptake 13.60 kW
Rated power 11.00 kW
Rated current 23.8 A
Start current 128.0 A

Cable

10m H07RN-F 4Cx2,5mm²/ 3Cx2,5mm²/2PNCT 2Cx2mm²

Motor Protection

Miniature protector in windings
(snap-action bi-metal device)

Shaft seal

Double inside mechanical seal in oil bath
additional lubrication by oil lifting device
Primary seal
Silicon carbide on silicon carbide
Secondary seal
Silicon carbide on silicon carbide

Bearings

Shielded ball bearings, maintenance-free

Materials

Impeller
FC20 (EN-GJL-200) + Tungsten carbide
Pump casing FC200 (EN-GJL-200)
Suction cover FCD700 (EN-GJS-700-2)
Motor Frame FC200 (EN-GJL-200)
Shaft SUS403 (EN-X6Cr13)

Discharge size

4" (100mm) JIS 10K screwed-in mating flange
guide rail fitting optional

Weight

177 kg (dry weight of the pump only without cable)

Performance curve

100C411-53

Discharge port	4"
Head	26.0 m
Flow	45.9 l/s
Rated power	11.00 kW
Power input	13.60 kW
Phases	3~
Voltages	400 V
Frequency	50 Hz
Rated current	23.8 A
Starting current	128.04 A
Number of poles	4
Speed	1445 1/min
Starting mode	Star-delta
Insulation class	F

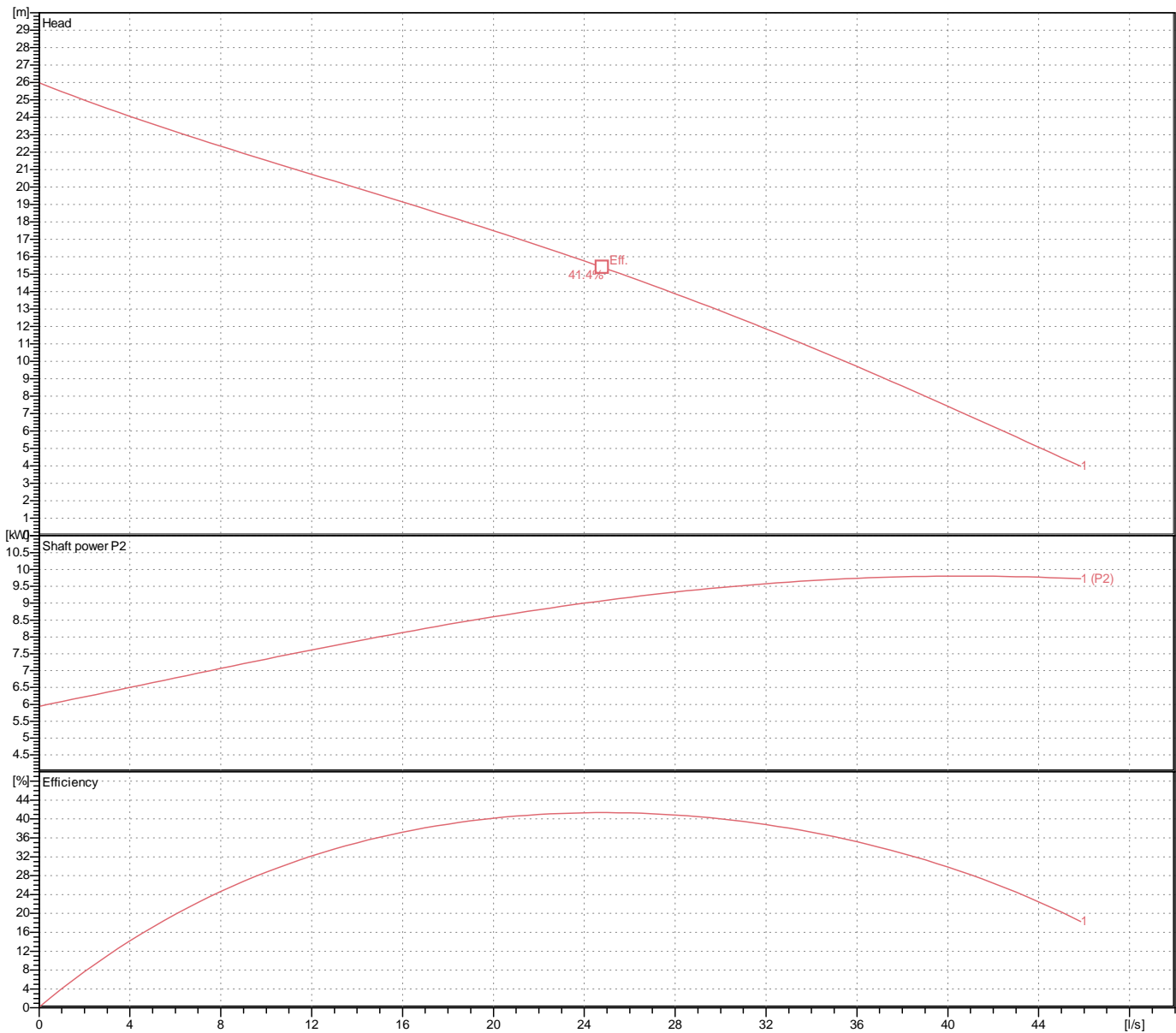

Dimensions TOS100C411-53

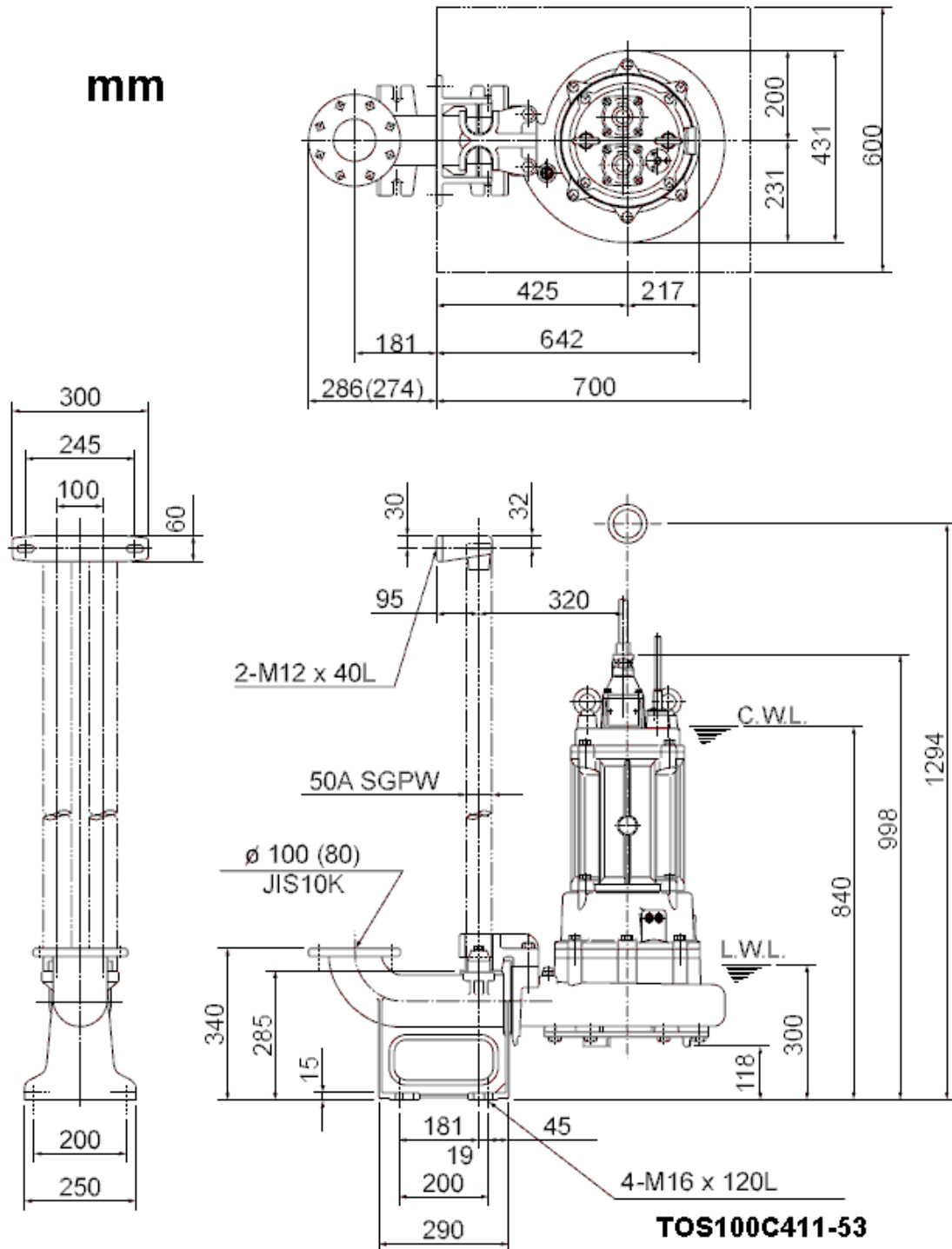

CWL: Continuous running water level
LWL: Lowest running water level

Sectional drawing TOS100C411-53

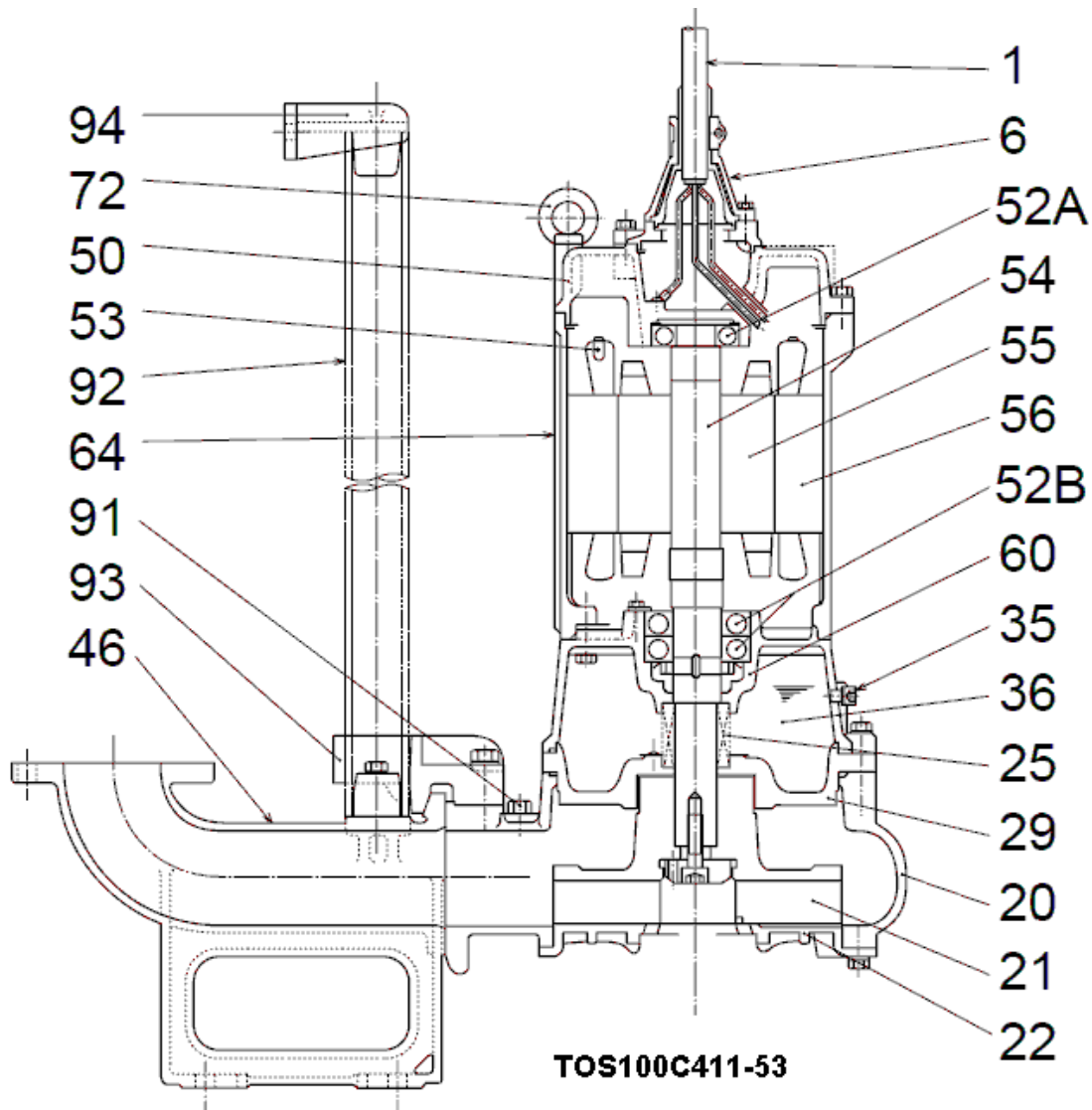

No.	Description	Remark	No.	Description	Remark
1	Cable (3x)	H07RN-F / 2PNCT-F	55	Rotor	.
6	Stuffing box	FC200 (EN-GJL-200)	56	Stator	.
20	Pump casing	FC200 (EN-GJL-200)	60	Bearing Housing	FC200 (EN-GJL-200)
21	Impeller	FC20 (EN-GJL-200) + Tungsten carbide	64	Motor Frame	FC200 (EN-GJL-200)
22	Suction cover	FCD700 (EN-GJS-700-2)	72	Eye screw (2x)	Construction steel SS400
25	Mechanical seal	H-35A	91	duck foot bend	FC200 (EN-GJL-200)
26	Oil seal	TC608212	92	Guide pipe (option) (2x)	Steel pipe
29	Oil casing	FC200 (EN-GJL-200)	93	guide support	FCD45 (EN-GJS-450-10)
35	Oil screw (2x)	SUS304 (EN-X5CrNi18-10)	94	Guide pipe holder	FCD45 (EN-GJS-450-10)
36	Lubricant	Turbine oil (ISO VG32)	95	Chain	Construction steel SS400
46	Air vent screw	Nylon			
50	Motor cover	FC200 (EN-GJL-200)			
52A	Upper bearing	6306ZZC3			
52B	Lower bearing	6309ZZC3			
53	Motor Protector 380/400/415V	50Hz KA314-HRXL00 (H.C)			
54	Shaft	SUS403 (EN-X6Cr13)			