

Data sheet 100BZ411-53

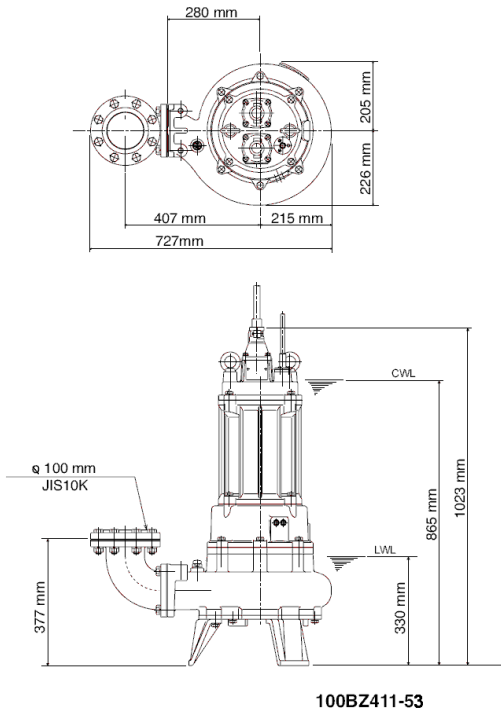

100BZ411-53

CWL: Continuous running water level
LWL: Lowest running water level

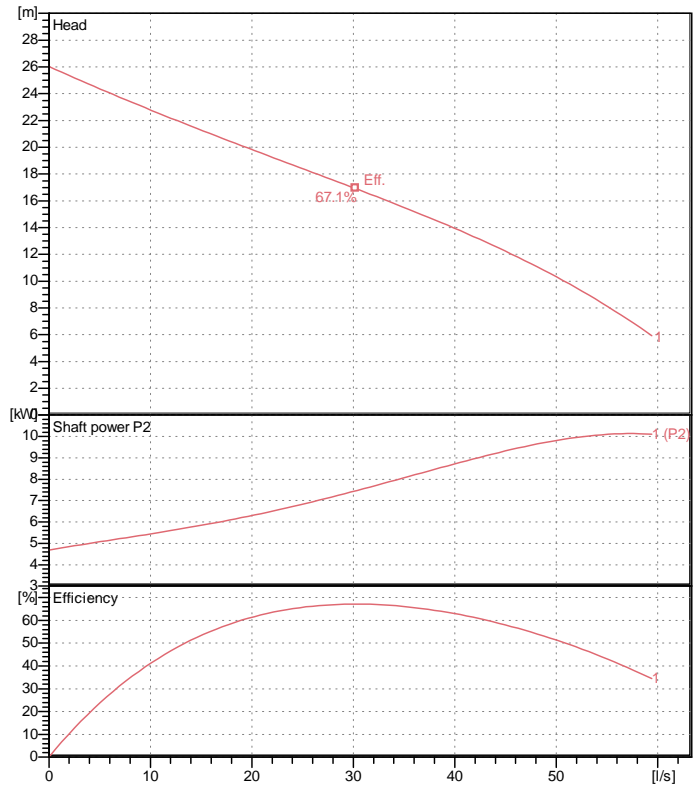

Specification

Electric submersible pump
Degree of protection IP 68
Depth of submersion max. 20 m
Type of impeller Single channel impeller
Free passage 80 mm
Suitable for:
sewage water

Electric motor

Dry-type submersible induction motor
Insulation class F 4 Poles 1445 1/min
Starting mode Star-delta
Rated voltage 400 V 50 Hz 3~
Power uptake 13.60 kW
Rated power 11.00 kW
Rated current 23.8 A
Start current 128.0 A

Cable

10m H07RN-F 4Cx2,5mm²/H07RN-F 3Cx2,5mm²/2PNCT 2Cx1,25mm² 4" (100mm) JIS 10K screwed-in mating flange
guide rail fitting optional

Motor Protection

Miniature protector in windings
(snap-action bi-metal device)

Shaft seal

Double inside mechanical seal in oil bath
additional lubrication by oil lifting device

Primary seal
Silicon carbide on silicon carbide
Secondary seal
Silicon carbide on silicon carbide

Bearings

Shielded ball bearings, maintenance-free

Materials

Impeller	FC200 (EN-GJL-200)
Pump casing	FC200 (EN-GJL-200)
Suction cover	FC200 (EN-GJL-200)
Motor Frame	FC150 (EN-GJL-150)
Shaft	SUS420J2 (EN-X30Cr13)

Discharge size

4" (100mm) JIS 10K screwed-in mating flange
guide rail fitting optional

Weight

219 kg (dry weight of the pump only without cable)

Performance curve

100BZ411-53

Discharge port	4"
Head	26.0 m
Flow	59.4 l/s
Rated power	11.00 kW
Power input	13.60 kW
Phases	3~
Voltages	400 V
Frequency	50 Hz
Rated current	23.8 A
Starting current	128.04 A
Number of poles	4
Speed	1445 1/min
Starting mode	Star-delta
Insulation class	F

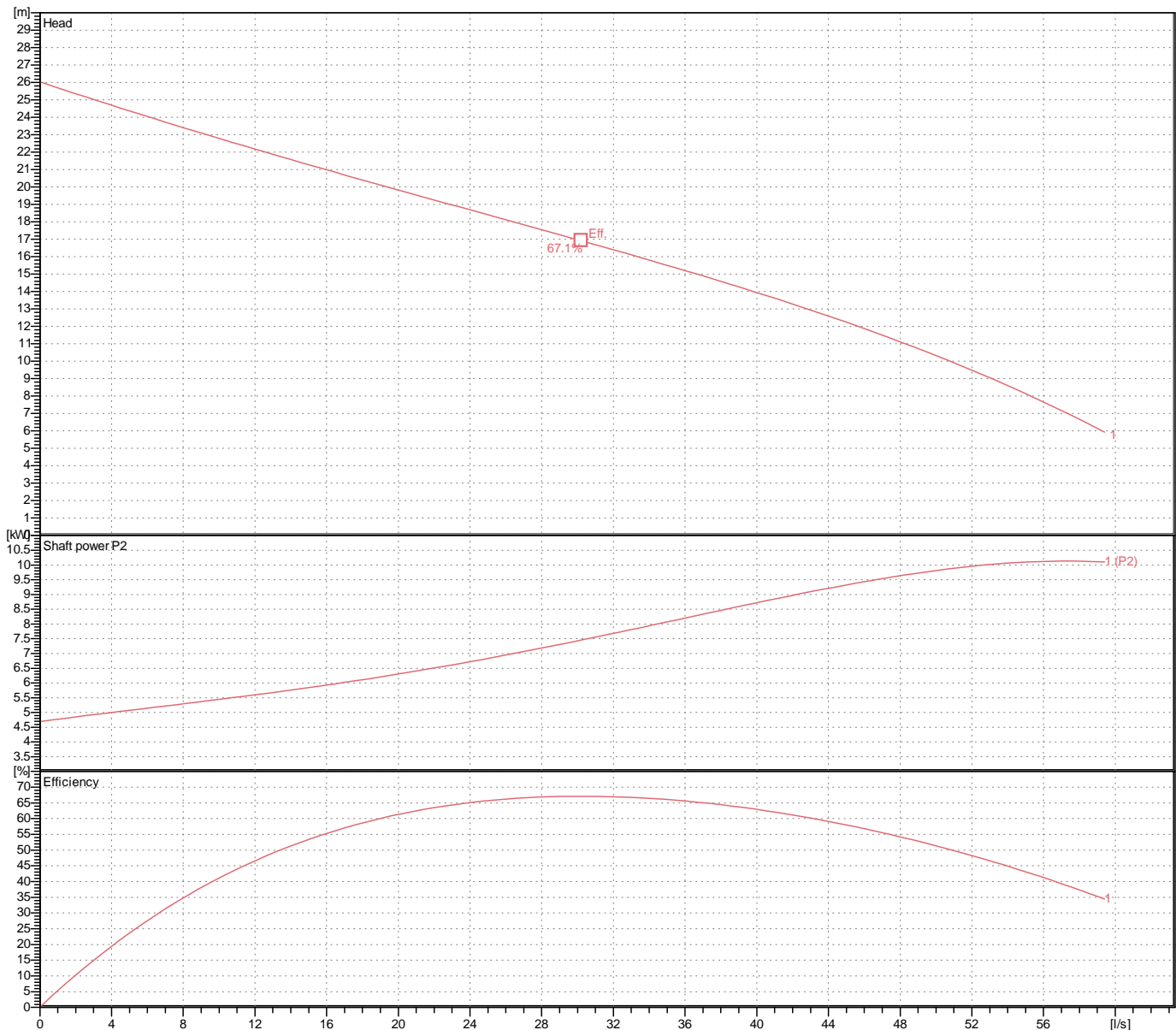

Dimensions 100BZ411-53

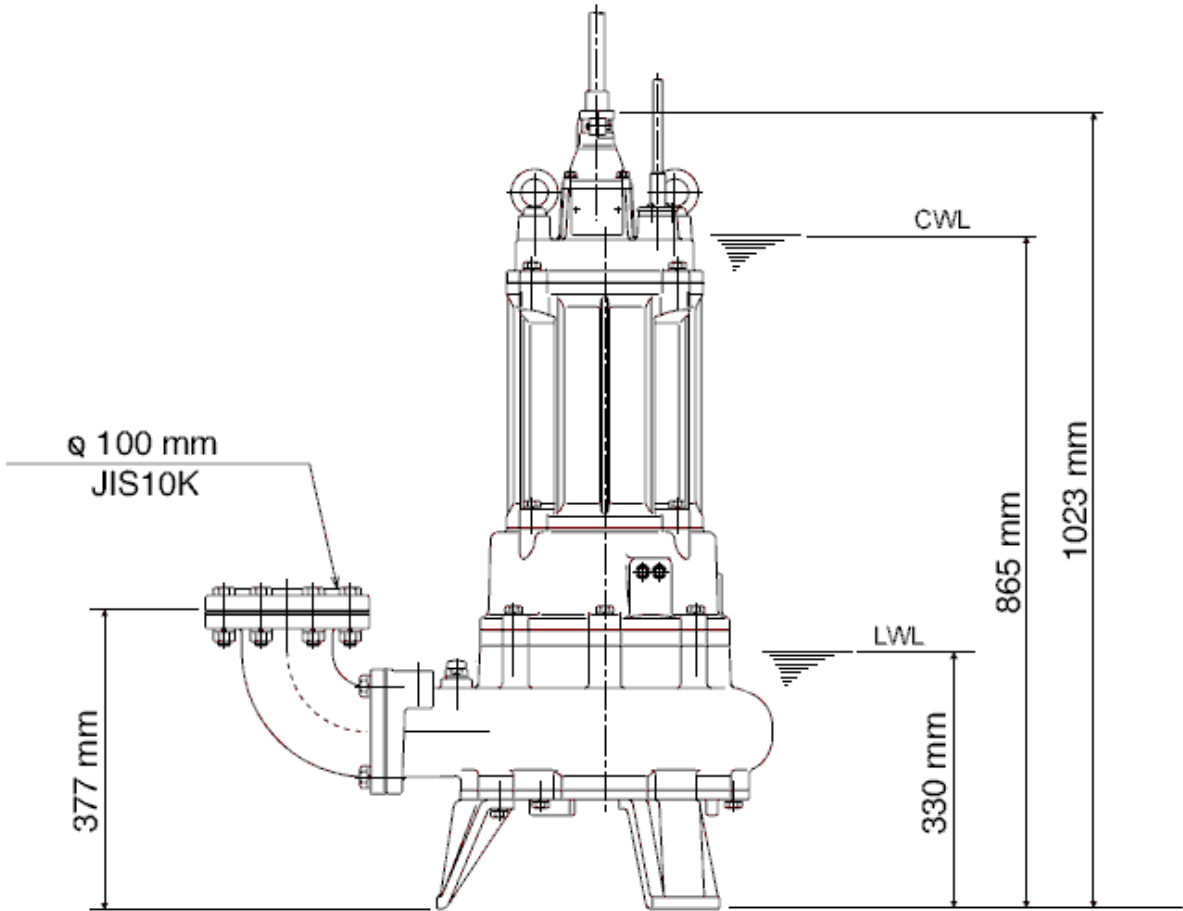
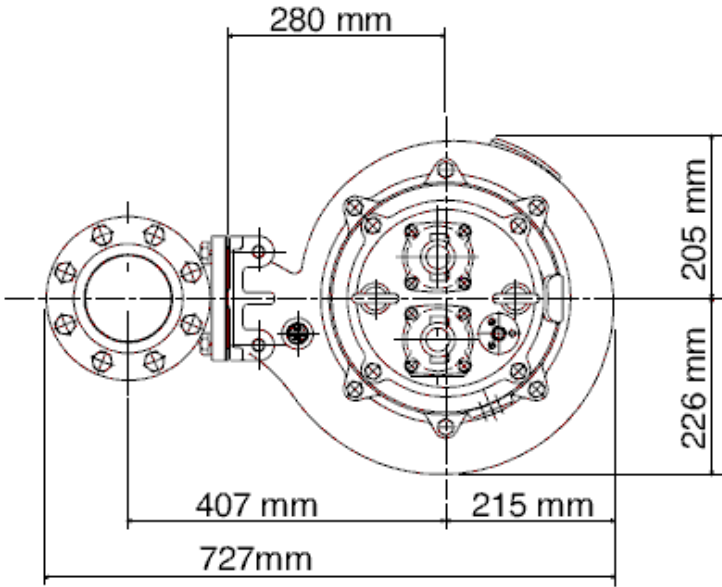

100BZ411-53

CWL: Continuous running water level
LWL: Lowest running water level

Sectional drawing 100BZ411-53

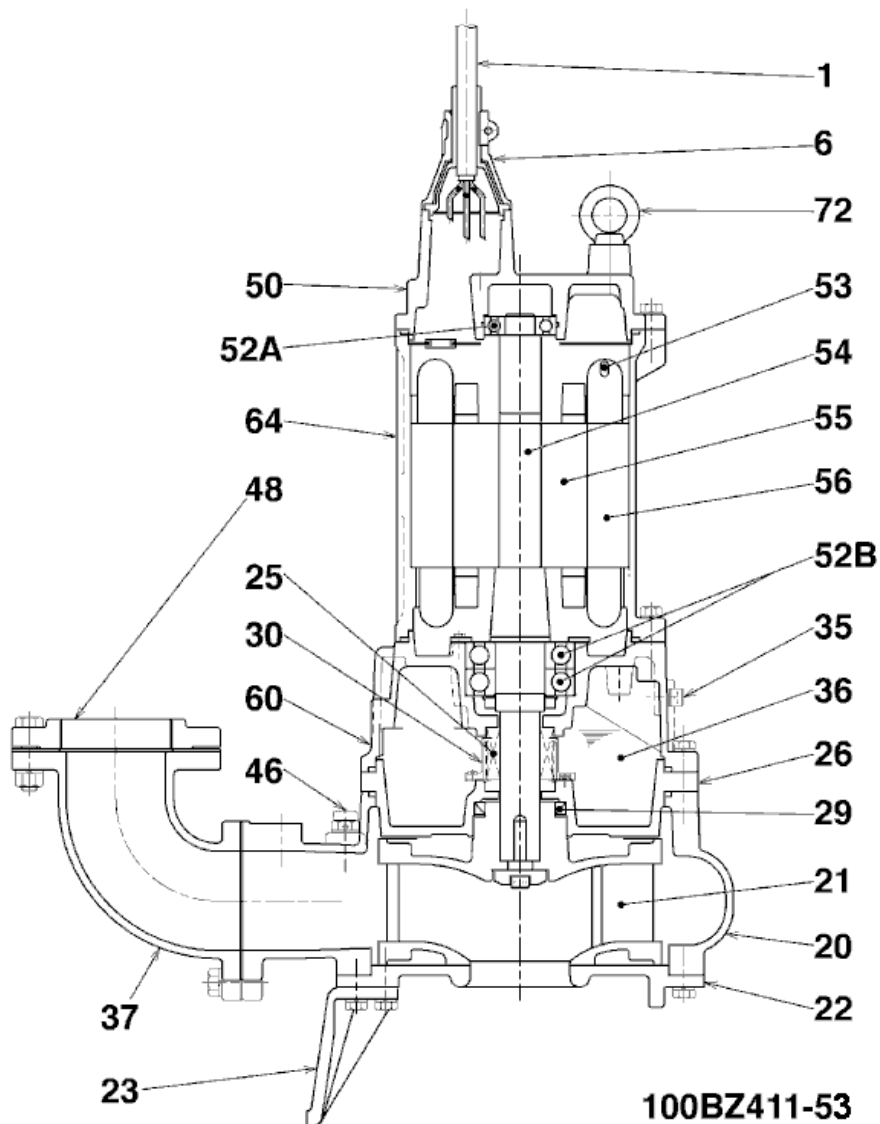

No.	Description	Remark	No.	Description	Remark
1	Cable (3x)	H07RN-F / 2PNCT-F	52A	Upper bearing	6306ZZC3
6	Cable entry (2x)	FC200 (EN-GJL-200)	52B	Lower bearing	6310ZZC3D3
20	Pump casing	FC200 (EN-GJL-200)	53	Miniature protector (3x)	.
21	Impeller	FC200 (EN-GJL-200)	54	Shaft	SUS420J2 (EN-X30Cr13)
22	Suction cover	FC200 (EN-GJL-200)	55	Rotor	.
23	Stand (3x)	FC200 (EN-GJL-200)	56	Stator	.
25	Mechanical seal	H-40X	60	Bearing Housing	FC150 (EN-GJL-150)
26	Oil seal	TC709212	64	Motor Frame	FC150 (EN-GJL-150)
29	Oil casing	FC200 (EN-GJL-200)	72	Eye screw (2x)	Construction steel SS400
30	Oil distributor	Plastic			
35	Oil screw (2x)	SUS304 (EN-X5CrNi18-10)			
36	Lubricant	Turbine oil (ISO VG32)			
37	Discharge bend	FC200 (EN-GJL-200)			
46	Air vent valve	Nylon			
48	Screwed Flange	FC200 (EN-GJL-200)			
50	Motor cover	FC200 (EN-GJL-200)			