

OWNER'S MANUAL

Model: LG-65-HP (5303623)
(65 Gallon Lawn & Garden Spot Sprayer)

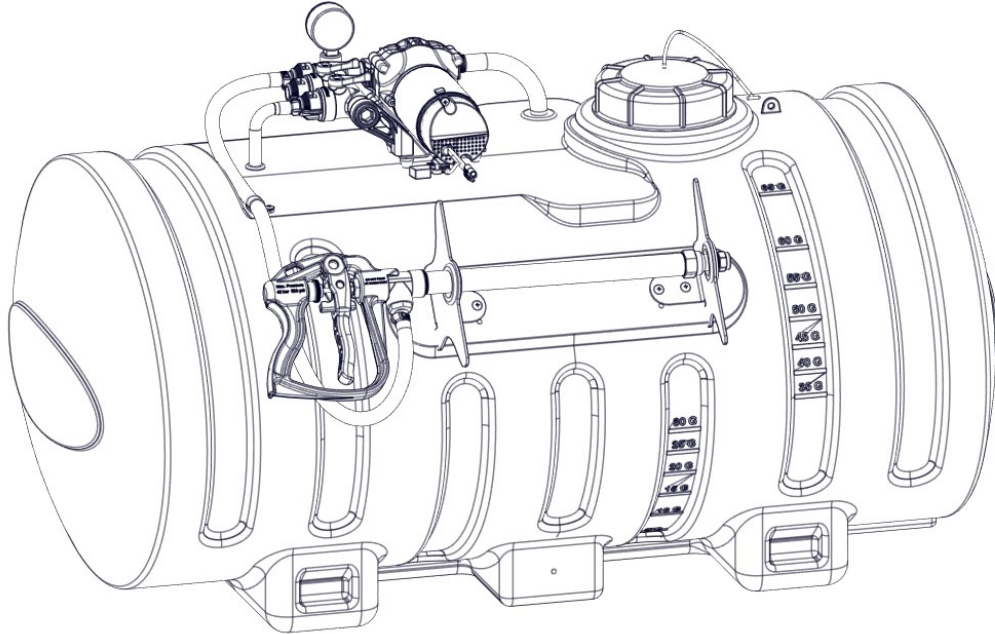

General Information

Thank you for purchasing this product. The purpose of this manual is to assist you in operating and maintaining your lawn & garden Spot sprayer.

**BEFORE RETURNING THIS PRODUCT
FOR ANY REASON, PLEASE CALL**

1-800-831-0027

MONDAY-FRIDAY, 8:00 AM TO 5:00 PM CST

If you should have a question or experience a problem with your Fimco Industries Product: Visit our website @ www.fimcoindustries.com or call the Toll free number above. Our technical support representatives will be happy to help you.

In most cases a customer service rep. can resolve the problem over the phone.

To obtain prompt, efficient service, always remember to give the following information....

- Correct Part Description and/or part number
- Model number and Serial Number

Part descriptions and numbers can be obtained from the illustrated parts list section(s) of this manual.

Retain a copy of your receipt for your unit, as it will be required to validate any warranty service.

Warranted against manufacturer or workmanship defects from date of purchase with copy of receipt:



Homeowner Usage: Sprayer-One Year and Pump-Two Years.

Commercial Usage: Sprayer and Pump-90 Days.



WARNING: Cancer and Reproductive Harm.
www.P65Warnings.ca.gov



WARNING: To reduce the risk of injury, the user must read and understand the operator's manual before using this product.

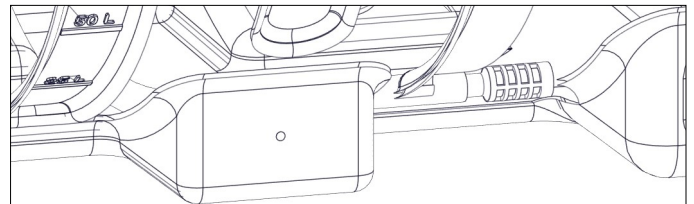

IMPORTANT:

Occasionally check the strainer screen to ensure it is clean and clear of any debris. Strainer is located on the end of the intake hose, inside of the tank. Use protective gear when removing hose from tank and cleaning the strainer.



www.fimcoindustries.com

1000 FIMCO Lane, P.O. Box 1700, North Sioux City, SD 57049
Toll Free Phone: 800-831-0027 : Toll Free Fax: 800-494-0440

[5195706

(06/22)]

Contents

Technical Specs and Assembly Instructions	2	Troubleshooting	5 - 6
Operation	3	Sprayer Exploded View/Parts List	7
Tank Care, Maintenance and Winter Storage	4	Sprayer Dimensions	8
Pump Exploded View/Parts List	5	Warranty	8

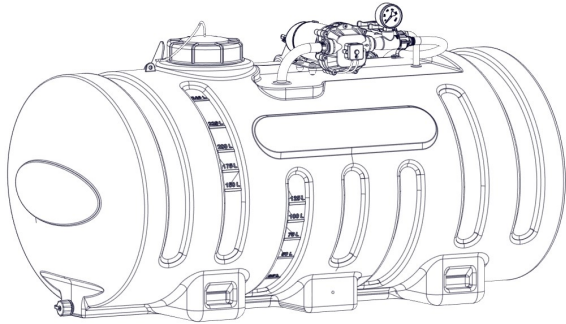

Model: LG-65-HP (5303623) (30 Gallon Lawn & Garden Spot Sprayer)

Technical Specifications

- 65 Gallon Corrosion-Resistant Polyethylene Tank
- 12 Volt Diaphragm Pump, 4.5 GPM - 60 PSI
- 22" High Pressure Aluminum Spray Gun
- 25 Ft. Handgun Hose (3/8" I.D.)
- 27 Ft. Max. Vertical Throw, 38 Ft. Horizontal Throw

**Caution: Always check the vehicle load rating before using the sprayer.
The loaded weight of this sprayer is approx.: 590 lbs. when the tank is full.**

~~~~~IMPORTANT~~~~~

Remove tank lid and be sure the tank is clean and free of any foreign material. Rinse tank out of any tank residue before filling with water to test.

~~~~~IMPORTANT~~~~~

It is VERY important to test this sprayer with plain water before actual spraying is attempted. This will enable you to familiarize yourself with the sprayer and check for leaks without the possibility of losing any expensive chemicals.

~~~~~WARNING~~~~~



Read and Understand the Owner's Manual before using this sprayer. Test and use in accordance to instructions.

Read and Follow chemical label instructions and wear protective gear when filling, using, cleaning and servicing the sprayer.

Exercise Caution in vehicle handling when towing/hauling a filled sprayer to avoid loss of control or overturning.

Keep Sprayer and Spray materials away from other people, children and pets.

Do Not Turn on Power to the sprayer, until ready to spray in order to avoid unintentional spray release.

Do Not Use on steep slopes. A full sprayer could cause loss of control or overturn sprayer and vehicle.

Always operate up and down a slope, never across the face of a slope.

Keep all movement on slopes slow and gradual. Do not make sudden changes in speed, directions or turning. Do not start or stop suddenly when going uphill or downhill.

Stop on level ground, set the parking brake and shut off engine before leaving the operator's position for any reason.

Keep all parts in good condition and properly installed. Fix damaged or worn parts immediately.

Caution should be taken when towing and/or using any sprayer. This sprayer combined with the weight distribution, turning radius and speed of vehicle can result in damage to vehicle and/or sprayer or severe injury or death, if not used properly.

Improper use of this sprayer or handling of chemicals could result in serious injury or illness, or could cause damage to the environment.

Assembly Instructions

This sprayer has been mostly assembled at the factory.

Attach the hose wraps and insert grommets, as shown.

Thread pressure gauge into the manifold assembly. Use a good grade of thread sealant or plumber's tape to ensure no leaks. Hand tight should be sufficient.

- Make sure all hose clamps are tight before testing or spraying for the first time.
- Connect sprayer lead wire to a fully charged 12V battery to power the sprayer pump. The towing vehicle battery can be used or a stand-alone 12V battery.
- Screw lid on to the tank.

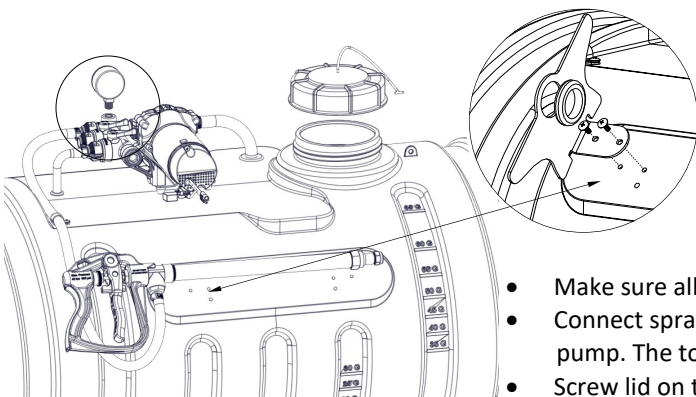

*****The Sprayer should now be ready to TEST w/plain water before actual use*****

IMPORTANT: Remove tank lid and be sure the tank is clean and free of any foreign material. Rinse tank out of any tank residue before filling with water to test.

Testing the Sprayer

NOTE:

It is VERY important to test this sprayer with plain water before actual spraying is attempted. This will enable you to check the sprayer for leaks without the possibility of losing any expensive chemicals.

Fill the tank about 1/2 full with plain water and drive to the starting place for spraying.

When you are ready to spray, close both valves on manifold (Detail A). This will start solution spraying from the spray gun when trigger is pulled. The pressure will decrease slightly when spraying.

Adjust the pressure by turning the "ON/OFF" valve lever on the 'Press. Adj.' (bypass) line valve (Detail B). Make sure your pattern is sufficient. You may down-pressure the system by 'bypassing' solution back into the tank. This is achieved by opening the 'Press. Adj.' (bypass) valve. Regulating pressure is done in this manner.

Read the operating instructions and initially begin spraying by closing both valves (Detail A). This will enable the air in the line to be eliminated (purged) through the tip, while building pressure. When everything tests all right (no leaks and good pressure), add the desired chemicals to the mixture and water combination and start your spraying operation. Adjust the pressure and spray as you did in the testing procedure.

Conditions of weather and terrain must be considered when setting the sprayer. Do not spray on windy days. Protective clothing must be worn in some cases.

Be sure to read the chemical label(s) before application!

Manifold Valves CLOSED

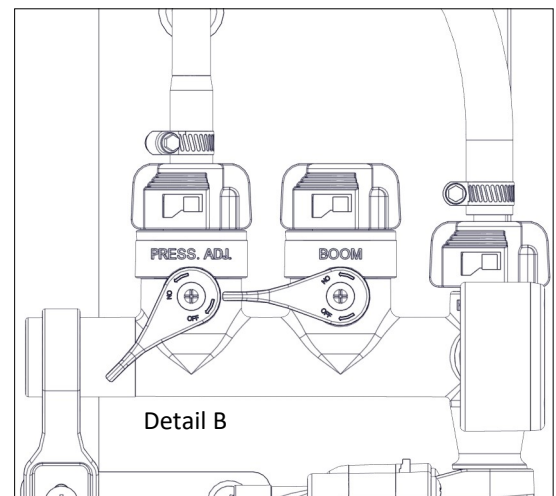
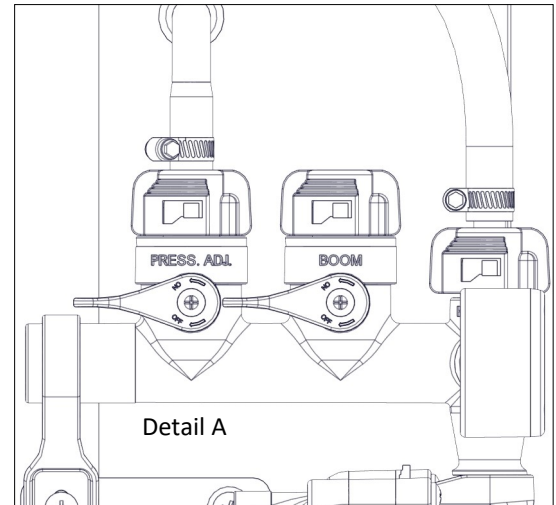

Operation

The pumping system draws solution from the tank, through the strainer and to the pump. The pump forces the solution under pressure to the handgun.

Fill the tank part way with water and then add the desired amount of chemical to be sprayed. Finish filling tank to proper level.

Only fill the tank with what you're going to spray in a day, never leave chemicals sit in tank.

Connect the lead wire to a fully charged 12 volt battery. You may use either a stand-alone battery or the battery on your towing vehicle. Connect to the positive (red) terminal first, then connect to the negative (black) terminal. Then connect the end of the lead wire to the end of the pump. When disconnecting, disconnect the end of the pump wire from the lead wire, then disconnect the negative (black) connection and finally the positive (red) connection. The lead wire has an On/Off switch to activate the pump. "I" is on and "O" is off.

Turn the pump on and by depressing the "I" side of the rocker switch. The pump is equipped with a pressure switch that is pre-set at the factory to shut the pump off when all discharges are closed.

The pump will turn back on when one of the following actions occurs:

- ◆ Handgun lever is squeezed to spray the handgun.
- ◆ Bypass valve is opened to re-circulate solution back into the tank.

When spraying with the handgun, pressure may be reduced by slowly opening the 'Press. Adj.' (bypass) valve until desired pressure is achieved. Opening the valve decreases pressure, closing the valve increases pressure.

Tank Care & Maintenance

Warning: Do not use the tank as a container for fuel oils, kerosene, gasoline or any other petroleum distillate product. All polyolefins are softened and permeated by such products. In an enclosed area the vaporization of these materials from the outside surface of the tank could create a dangerous condition.

The tank should not be used as a pressure vessel nor used with chemicals or solutions having a weight of more than 12 pounds per gallon.

Store the tank in a dry dark place when not in use. Storage out of sunlight will prolong the life of the tank.

Do not drop, strike or kick the tank, especially at low temperatures. Tanks become brittle and are subject to cracking at temperatures below 20° Fahrenheit.

Always flush the tank with water and a neutralizing agent at the end of each use, to prevent contamination of solutions.

Maintenance During/After Spraying

Periodically check the strainer and clean the screen on your intake line.

If sprayer becomes clogged during use, discontinue use immediately. DO NOT attempt to service while chemicals are in the sprayer and power is connected.

Proper care and maintenance will prolong the life of your sprayer.

After use, drain the tank and store or dispose of chemical properly. Fill the sprayer half way with clean water. Start the pump and allow the water to pump through the entire plumbing system and nozzles. Drain and then refill half full, add the recommended amount of a good quality tank cleaner, such as FIMCO Tank Neutralizer and Cleaner. (If no tank cleaner is available, you may substitute dish soap for this step, about 1-2 oz. per gallon). But a neutralizer/cleaner should be used to thoroughly clean the system. Turn pump on and circulate through system for 15 minutes and then spray out through boom and handgun nozzles. Refill sprayer half way with clean water and repeat. Follow the chemical manufacturer's disposal instructions of all wash or rinsing water.

If handgun nozzle needs cleaning, remove from the sprayer and soak in warm soapy water. Clean with a soft bristled brush or toothpick if necessary. Never use a metal object. Even the slightest damage can change the flow rate and spray distribution. Water rinse and dry the tip before storing.

WARNING: Some chemicals will damage the pump valves if allowed to soak untreated for a length of time! ALWAYS flush the pump as instructed after each use. DO NOT allow chemicals to sit in the pump for extended times of idleness. Follow the chemical manufacturer's instructions on disposal of all waste water from the sprayer.

Winter Storage

Prepare the sprayer for end-of-season storage by running RV antifreeze through the system. This will keep internal parts lubricated, protect against corrosion and keep the unit from freezing. *Note: RV antifreeze is non-toxic and biodegradable and generally safer for the environment than automotive antifreeze.*

Before storing your sprayer for winter or long term storage, thoroughly clean and drain it as much as possible. Then pour enough pink RV antifreeze into the tank so that when the pump is turned on you can pump the antifreeze throughout the entire plumbing system, including the bypass, if equipped. Make sure to operate the handgun until you see pink fluid spraying from the nozzle. Leave any remaining antifreeze in the tank. Before your next usage, rinse the antifreeze from the sprayer with clean water.

It is nearly impossible to drain all of the water from the sprayer and any trapped water can freeze in cold weather and damage parts of the sprayer. Pumping the antifreeze through the system will displace the water and help prevent this damage.

Removing from storage: drain the antifreeze. Fill the tank with fresh water and run through the system. Dispose of antifreeze and flush water properly.

Before Troubleshooting or Attempting to Service the Pump:

- ◆ **Review Troubleshooting Chart:** Do Not attempt to repair until steps below are followed.
- ◆ **Personal Protective Gear:** Wear protective gear when servicing pump.
- ◆ **Disconnect Power:** Disconnect the power to the pump and relieve the pressure from the system.
- ◆ **Empty and Flush** the pump system with water, never attempt to service the pump until it has been emptied and flushed.
- ◆ **Perform Repairs:** Follow directions provided in the troubleshooting section to repair the pump.
- ◆ **Test:** Always test the pump for leaks with plain water after any repairs before using.

STOP WARNING STOP
 DO NOT USE PUMP IN AN EXPLOSIVE ENVIRONMENT. DO NOT USE TO PUMP FLAMMABLE/COMBUSTIBLE FLUIDS, GASOLINE, KEROSENE, FUEL, OIL, ETC.

HIGHFLO
 HIGH PERFORMANCE

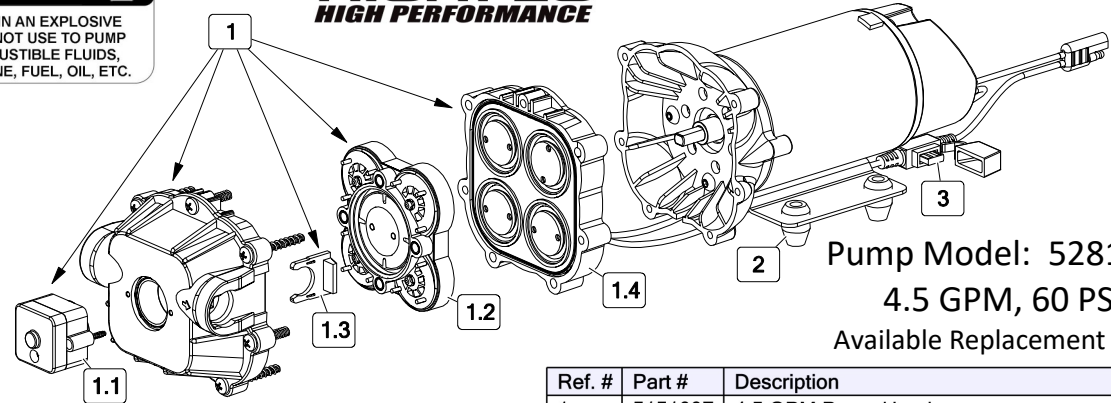

Pump Model: 5281372
 4.5 GPM, 60 PSI
 Available Replacement Parts

Replacement Pump: 5151088

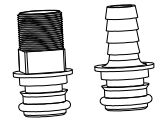

- Includes:
 1/2" MNPT Port Kit Fitting #5168832
 1/2" Hose Barb Port Kit Fitting #5168833

Ref. #	Part #	Description	Qty
1	5151097	4.5 GPM Pump Head	1
1.1	5164271	60 PSI Pressure Switch	1
1.2	5168824	Check Valve w/O-Ring	1
1.3	5051162	Pump Slide Clips (Pkg/2)	1
1.4	5063271	4.5 GPM Diaphragm/Piston/Cam/Bearing Kit	1
2	5075019	Grommets (Pkg/4)	1
3	5157206	15 Amp 'Mini Blade' Fuse	1

DO

- Clean and rinse your pump after each use with Fimco Tank Neutralizer.
- Winterize your pump or sprayer by rinsing, draining and running RV Antifreeze through it before storing for the winter.
- Use clean water for your spray mixture.
- Store inside a building when not in use.

DON'T

- Use to pump bleach.
- Use to pump petroleum products such as diesel fuel, gasoline or kerosene.
- Use to pump chemicals w/petroleum distillates or surfactants.
- Leave your pump sit with spray mixture in it for extended periods.
- Use dirty or unfiltered water for spraying.

CAUTION
 PRESSURE SWITCH OPERATION
 Pressure switch is pre-set at the factory. Improper adjustment of the pressure switch, may cause severe overload or premature failure. If the pump is subjected to rapid cycling during normal operation, or infrequent periods, damage may occur.

Troubleshooting

Pump will not run:	Check for loose wiring	Pump surges:	Low flow may cause pump to surge	
	Make sure the ON/OFF switch is on		Spray Wand is adjusted to small or fine of a spray pattern	
	Check the fuse		Check for defective pressure switch	
	Check for defective pressure switch		Check for leaks in the discharge line	
	Check to see if connected to good 12 Volt Power Source		Check for debris in nozzle orifice	
	Check for Low Voltage		Discharge hose may be too long	
Pump Does Not Prime (No Discharge w/Motor Running)	Check for clogged strainer/filter	Pump continues to run:	Check for worn or dirty check valve	
	Check for kinked inlet/outlet hoses		Check for empty product supply	
	Check for empty product supply		Check for Low Voltage	
	Check for defective check valve		Check for leaks in the discharge line	
	Check for debris in the check valve assembly		Check for defective pressure switch	
	Check for cracks in the pump housing		System has leaks	
Low Pressure/ Low Flow:	Check for air leaks in supply line	Fuse blows:	Air trapped in outlet line or pump head	
	Check for a clogged strainer		Excessive voltage	
	Check for proper voltage		Try another 12-Volt battery	Improper adjustment of pressure switch
	Check for leaks in the discharge line		Check for restrictions in the discharge line	Damaged or defective wiring harness
	Check for debris in intake		Check for debris in nozzle orifice	Defective pressure switch
	Check for worn or dirty check valve			

Before Troubleshooting or Attempting to Service the Pump:

- ◆ **Review Troubleshooting Chart:** Do Not attempt to repair until steps below are followed.
- ◆ **Personal Protective Gear:** Wear protective gear when servicing pump.
- ◆ **Disconnect Power:** Disconnect the power to the pump and relieve the pressure from the system.
- ◆ **Empty and Flush** the pump system with water, never attempt to service the pump until it has been emptied and flushed.
- ◆ **Perform Repairs:** Follow directions provided in the troubleshooting section to repair the pump.
- ◆ **Test:** Always test the pump for leaks with plain water after any repairs before using.

Motor is NOT Running - Checking the Pressure Switch:

If motor is not running and you've checked the following: for loose wiring connections, fuse, switch on lead wire was "ON" and made sure you were connected to a fully charged battery but the motor won't run, then it's time to check to see if the pressure switch is bad.

- Remove the cover off the 1" square box (pressure switch) on the head of the pump, the cover is held on by one phillips-head screw. This will expose the two red wires.
- With the pump connected to a good 12 volt power source and everything on.
- Slip the two red wires off the terminals and touch them together.

- ◆ If motor runs, it means the pressure switch is bad and needs to be replaced.
- ◆ If motor still doesn't run, try bypassing the switch in the lead wire or using another lead wire. Even if a tester shows power to the pressure switch, still try this test.

Warning: It is NOT recommended to run the pump this way, as the pump will continue to run and not shut off.

This could result in blown hoses when all discharges are closed or premature failure of the pump completely.

Motor Running-No Pressure - - Cleaning the Check Valve:

Experiencing little to no pressure or pump is not priming and filter screen is clean and plumbing is good with no leaks, you may need to clean the check valve.

- Remove the head of the pump, which is held on by 7 screws.
- First part inside the head of the pump is the check valve, this part responsible for building up pressure and pumping water/solution through the lines.
- Clean the check valve under hot, soapy water (such as a good grade dish soap).
- Lightly scrub, if needed, with something like an old toothbrush, something with soft bristles.
- Let soak for about an hour or so in the hot soapy solution, replace in the pump and reassemble.

Most times this will restore most, if not all of the prime of a pump.

If still having issues with pressure after this step, it would be recommended to replace this part.

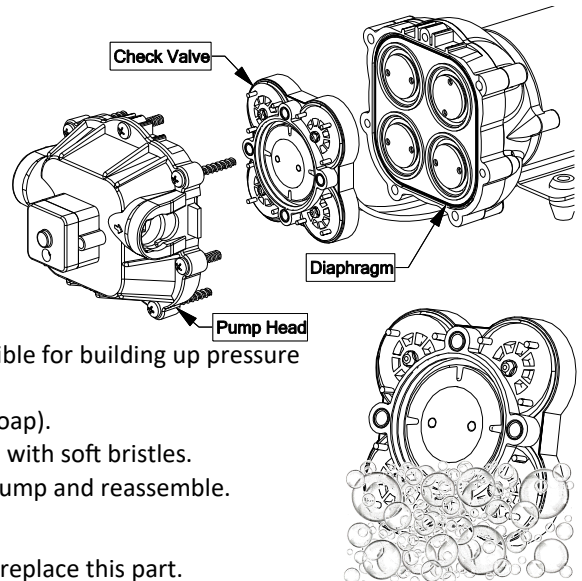
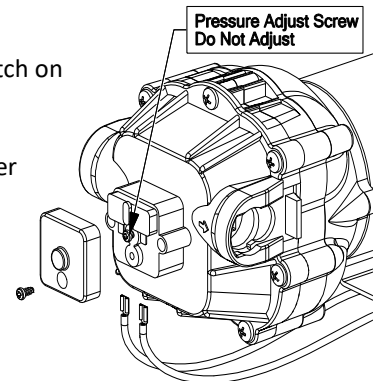

Sprayer and Pump FAQs:

◆ **Why does the pump not run all the time?**

This is an on-demand pump and only runs when a discharge is open (spray gun, bypass, boom (if applicable) or a leak in the system).

◆ **Why does the pump surge while using the spray gun?**

Low flow/high pressure may cause the pump to surge (or cycle). Typically the spray wand is adjusted at too fine of a mist, to overcome, adjust the nozzle for a higher flow.

◆ **How do I adjust the pressure?**

Pressure can only be adjusted by opening the pressure adjust (bypass) valve to allow some of your water or solution to return to the tank (if equipped).

◆ **Pump quit and will not run, what do I need to do?**

Squeeze trigger on spray gun to ensure that the system isn't just pressurized up with discharges closed.

Check electrical connections, ensure switch is on. Check fuses. Check for proper voltage. Check pressure switch.

◆ **Low flow or no flow at all, what do I need to check for?**

Check for a clogged intake hose and/or intake strainer. Check for proper voltage.

You will need to occasionally check your intake strainer to ensure that it is clean of any debris.

◆ **What is causing the fuse to blow each time I turn the pump on?**

Check for excessive voltage. Improper adjustment of the pressure switch. Damaged or defective wire harness or defective pressure switch.

Warning:

Ensure the wiring harness does not become pinched or damaged in any way. This may damage the pump or cause the wiring harness to overheat, resulting in a melt down or fire.

Exploded View/Parts List: LG-65-HP (5303623)

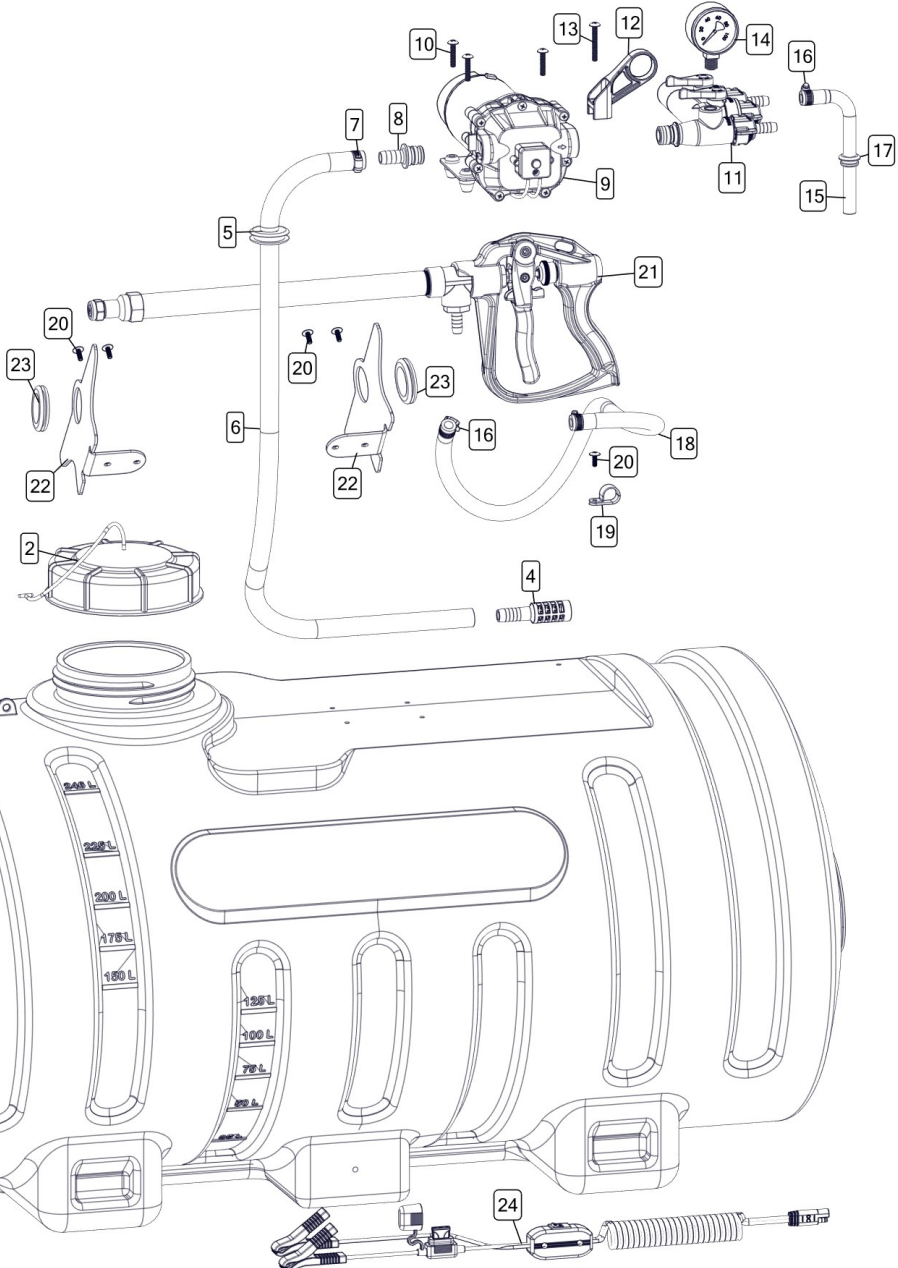
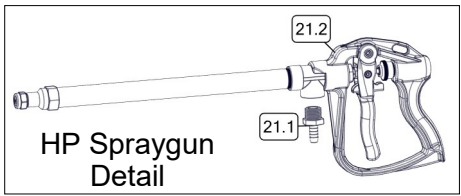
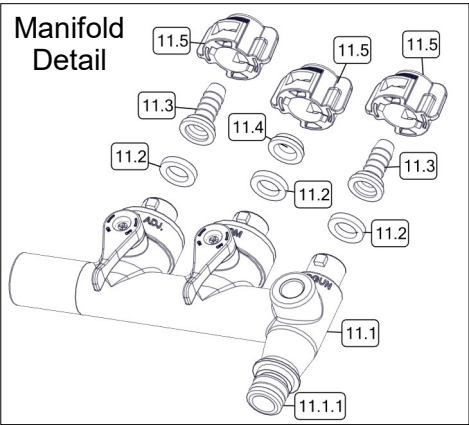

Ref. #	Part #	Description	Qty
1	5169363	65 Gallon Elliptical Tank	1
2	5058188	Tank Lid w/Lanyard	1
3	5274373	Drain Plug Assembly	1
4	5116477	1/2" Hose Barb Suction Strainer	1
5	5075016	Rubber Grommet	1
6	5020028	Hose 1/2"-1 Brd. x 33"	1
7	5051114	Hose Clamp, 1/2"	1
8	5168833	1/2" Hose Barb Port Fitting	1
9	5281372	4.5 GPM Pump, 60 PSI	1
10	5117168	#10-24 x 1.00 PH Truss Head Screw	3
11	5281536	Quick Connect Manifold Assembly	1
11.1	5302347	Quick Connect Manifold (Body)	1
11.1.1	5072514	O-Ring - Pump Port Connection	1
11.2	5143430	Flat Washer - Hose Barb Seal	3
11.3	5143431	QC Manifold - 3/8" Hose Straight Barb	2
11.4	5143435	QC Manifold - Quarter Turn Cap Plug	1
11.5	5143429	Quick Connect Quarter Turn Cap	3

Ref. #	Part #	Description	Qty
12	5143422	QC Manifold - Support Bracket	1
13	5117338	#10-24 x 1.50 PH Truss Head Screw	1
14	5167007	Pressure Gauge, 0-100 PSI	1
15	5100961	Formed Bypass Tube	1
16	5051144	Hose Clamp, 3/8"	3
17	5075018	Grommet	1
18	5020527	Hose, 3/8"-1 Brd. x 25 Ft.	1
19	5051122	5/8" Black Nylon Loom Cable Clamp	1
20	5117234	#10-24 x 0.50 PH Truss Head Screw	5
21	5163150	22" HP Spray Gun with 3/8" Hose Barb	1
21.1	5067130	Poly Fitting, 1/2" MNPT x 3/8" HB	1
21.2	5163136	High Pressure Aluminum Spray Gun 22"	1
22	5038923-BLK	HP Gun Hose Wrap Bracket	2
23	5075014	Rubber Grommet (Black)	2
24	5278114	Lead Wire w/15A Fuse (96" Long)	1
24.1	5157238	15 Amp Regular Blade Fuse	1

Approx. Dimensions:

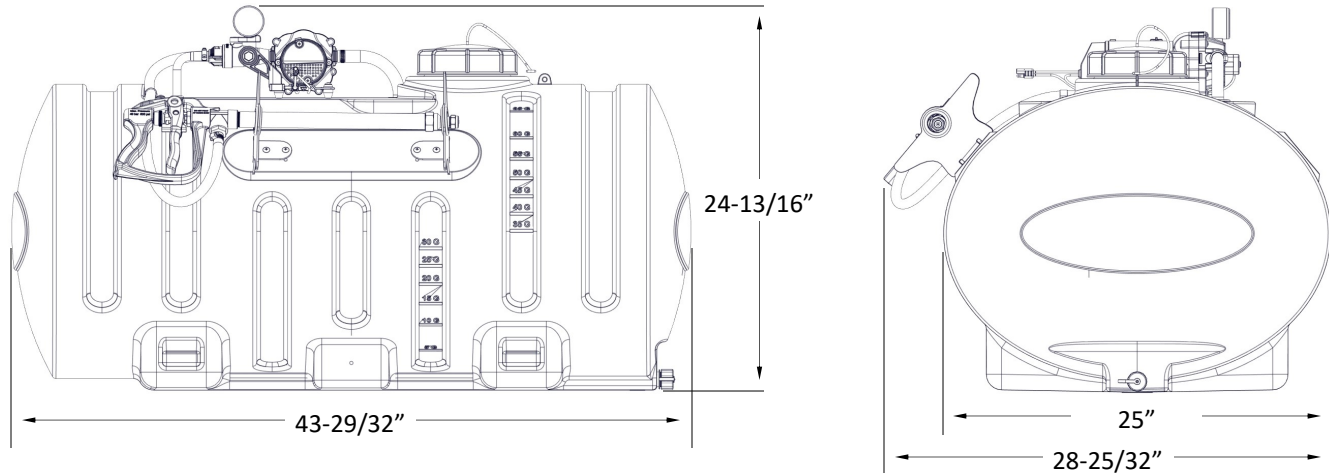

Warranty

LIMITED WARRANTY FOR NEW FIMCO, IND. EQUIPMENT

WHO MAY USE THIS LIMITED WARRANTY. This limited warranty (the "Limited Warranty") is provided by Fimco, Ind. to the original purchaser ("you") of the Equipment (as defined below) from Fimco, Ind. or one of Fimco, Ind.'s authorized dealers. This Limited Warranty does not apply to any subsequent owner or other transferee of the Equipment. THIS LIMITED WARRANTY GIVES YOU SPECIFIC LEGAL RIGHTS, AND YOU MAY ALSO HAVE OTHER RIGHTS WHICH VARY FROM STATE TO STATE.

WHAT THIS LIMITED WARRANTY COVERS AND FOR HOW LONG. Fimco, Ind. warrants that any new Equipment will be free from defects in material and workmanship for a period of **one (1) year** for sprayer and **two (2) years** for High-Flo High Performance pump (homeowner), **90 days** for sprayer and pump (commercial user), after delivery of the Equipment to you (the "Warranty Period"). The Warranty Period is not extended if Fimco, Ind. repairs or replaces the Equipment.

WHAT IS NOT COVERED BY THIS LIMITED WARRANTY. This Limited Warranty does not apply to: (1) used Equipment; (2) any Equipment that has been altered, changed, repaired or treated since its delivery to you, other than by Fimco, Ind. or its authorized dealers; (3) damage or depreciation due to normal wear and tear; (4) defects or damage due to failure to follow Fimco, Ind.'s operator's manual, specifications or other written instructions, or improper storage, operation, maintenance, application or installation of parts; (5) defects or damage due to misuse, accident or neglect, "acts of God" or other events beyond Fimco, Ind.'s reasonable control; (6) accessories, attachments, tools or parts that were not manufactured by Fimco, Ind., whether or not sold or operated with the Equipment; or (7) rubber parts, such as tires, hoses and grommets.

HOW TO OBTAIN WARRANTY SERVICE. To obtain warranty service under this Limited Warranty, you must (1) provide written notice to Fimco, Ind. of the defect during the Warranty Period and within **thirty (30) days** after the defect becomes apparent or the repair becomes necessary, at the following address: Fimco, Ind., 1000 Fimco Lane, North Sioux City, SD 57049; and (2) make the Equipment available to Fimco, Ind. or an authorized dealer within a reasonable period of time. For more information about this Limited Warranty, please call: **800-831-0027**.

WHAT REMEDIES ARE AVAILABLE UNDER THIS LIMITED WARRANTY. If the conditions set forth above are fulfilled and the Equipment or any part thereof is found to be defective, Fimco, Ind. shall, at its own cost, and at its option, either repair or replace the defective Equipment or part. Fimco, Ind. will pay for shipping and handling fees to return the repaired or replacement Equipment or part to you.

LIMITATION OF IMPLIED WARRANTIES AND OTHER REMEDIES. THE REMEDIES DESCRIBED ABOVE ARE YOUR SOLE AND EXCLUSIVE REMEDIES, AND FIMCO, IND.'S SOLE LIABILITY, FOR ANY BREACH OF THIS LIMITED WARRANTY. TO THE EXTENT APPLICABLE, ANY IMPLIED WARRANTIES, INCLUDING, WITHOUT LIMITATION, THE IMPLIED WARRANTIES OF MERCHANTABILITY AND FITNESS FOR A PARTICULAR PURPOSE, SHALL BE LIMITED IN DURATION TO THE WARRANTY PERIOD, AND THE REMEDIES AVAILABLE FOR BREACH THEREOF SHALL BE LIMITED TO THE REMEDIES AVAILABLE UNDER THIS EXPRESS LIMITED WARRANTY. SOME STATES DO NOT ALLOW LIMITATIONS ON HOW LONG AN IMPLIED WARRANTY LASTS, SO THE ABOVE LIMITATION MAY NOT APPLY TO YOU. IN NO EVENT SHALL FIMCO, IND.'S LIABILITY UNDER THIS LIMITED WARRANTY EXCEED THE ACTUAL AMOUNT PAID BY YOU FOR THE DEFECTIVE EQUIPMENT, NOR SHALL FIMCO, IND. BE LIABLE, UNDER ANY CIRCUMSTANCES, FOR ANY CONSEQUENTIAL, INCIDENTAL, SPECIAL OR PUNITIVE DAMAGES OR LOSSES, WHETHER DIRECT OR INDIRECT. SOME STATES DO NOT ALLOW THE EXCLUSION OR LIMITATION OF INCIDENTAL OR CONSEQUENTIAL DAMAGES, SO THE ABOVE LIMITATION OR EXCLUSION MAY NOT APPLY TO YOU.