

OWNER'S MANUAL

Model: 3PT-65-12V-BL (5303251)
(65 Gallon, 12 Volt, Bolt-Together, 3-Point Sprayer w/Boomless Boom)

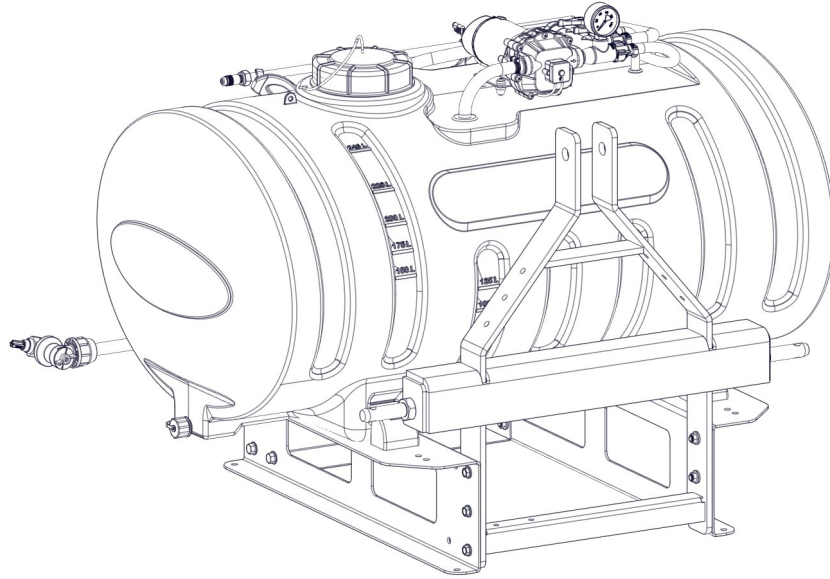

Category I

General Information

Thank you for purchasing this product. The purpose of this manual is to assist you in operating and maintaining your 3-Point sprayer.

BEFORE RETURNING THIS PRODUCT
FOR ANY REASON, PLEASE CALL

1-800-831-0027

MONDAY-FRIDAY, 8:00 AM TO 5:00 PM CST

If you should have a question or experience a problem with your Fimco Industries Product: Visit our website @ www.fimcoindustries.com or call the Toll free number above. Our technical support representatives will be happy to help you. In most cases a customer service rep. can resolve the problem over the phone.

To obtain prompt, efficient service, always remember to give the following information...

- Correct Part Description and/or part number
- Model number and Serial Number

Part descriptions and numbers can be obtained from the illustrated parts list section(s) of this manual.

Retain a copy of your receipt for your unit, as it will be required to validate any warranty service.

Warranted against manufacturer or workmanship defects from date of purchase with copy of receipt:



Homeowner Usage: Sprayer-One Year and Pump-Two Years.

Commercial Usage: Sprayer and Pump-90 Days.



WARNING: To reduce the risk of injury, the user must read and understand the operator's manual before using this product.



WARNING: Cancer and Reproductive Harm.
www.P65Warnings.ca.gov

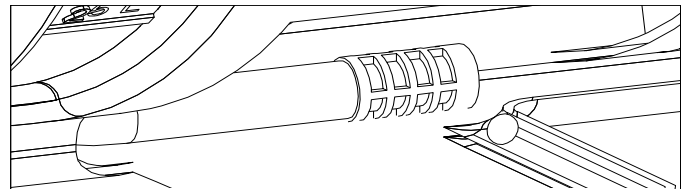

IMPORTANT:

Occasionally check strainer screen to ensure it is clean and clear of any debris. Strainer is located on the end of the intake hose, inside of the tank. Use protective gear when removing hose from tank and cleaning the strainer.



www.fimcoindustries.com

1000 FIMCO Lane, P.O. Box 1700, North Sioux City, SD 57049
Toll Free Phone: 800-831-0027 : Toll Free Fax: 800-494-0440

[5195639

(07/22)]

Contents

Technical Specs	2	Pump Exploded View and Parts List.....	10
Sprayer Contents.....	3	Trouble Shooting.....	9 - 11
Sprayer Assembly	4 - 6	Sprayer Exploded View and Parts List	12
Operation	7	Boom Exploded View and Parts List.....	13
Calibration & Tank Care	8	Sprayer Dimensions.....	13
Maintenance and Winter Storage.....	9	Warranty.....	14

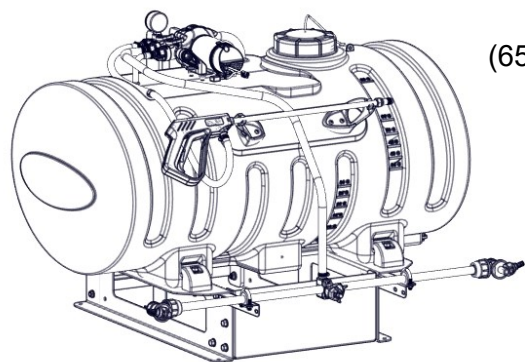

Model: 3PT-65-12V-BL (5303251)

(65 Gallon, 12 Volt, Bolt-Together, 3-Point Sprayer w/Boomless Boom)

Technical Specifications

- 65 Gal. Corrosion-Resistant Polyethylene Tank
- 12 Volt Diaphragm Pump, 4.5 GPM - 60 PSI
- Deluxe Pistol Grip Handgun
- 25' Handgun Hose (3/8" I.D.)
- 28' Vertical throw, 40' Horizontal Throw
- Bolt-Together Frame
- Boomless Boom Assembly, 36' Spray Coverage

CAUTION: When fully filled with water, this sprayer will weigh approx. 670 Lbs. Always check the vehicle load rating before using this sprayer. Do not exceed the recommended rating.

~~~~~IMPORTANT~~~~~

Remove tank lid and be sure the tank is clean and free of any foreign material. Rinse tank out of any tank residue before filling with water to test.

~~~~~IMPORTANT~~~~~

It is VERY important to test this sprayer with plain water before actual spraying is attempted. This will enable you to check the sprayer for leaks without the possibility of losing any expensive chemicals.

~~~~~WARNING~~~~~



Read and Understand the Owner's Manual before using this sprayer. Test and use in accordance to instructions.

Read and Follow chemical label instructions and wear protective gear when filling, using, cleaning and servicing the sprayer.

Exercise Caution in vehicle handling when towing/hauling a filled sprayer to avoid loss of control or overturning.

Keep Sprayer and Spray materials away from other people, children and pets.

Do Not Turn on Power to the sprayer, until ready to spray in order to avoid unintentional spray release.

Do Not Use on steep slopes. A full sprayer could cause loss of control or overturn sprayer and vehicle.

Always operate up and down a slope, never across the face of a slope.

Keep all movement on slopes slow and gradual. Do not make sudden changes in speed, directions or turning. Do not start or stop suddenly when going uphill or downhill.

Stop on level ground, set the parking brake and shut off engine before leaving the operator's position for any reason.

Keep all parts in good condition and properly installed. Fix damaged or worn parts immediately.

Caution should be taken when towing and/or using any sprayer. This sprayer combined with the weight distribution, turning radius and speed of vehicle can result in damage to vehicle and/or sprayer or severe injury or death, if not used properly.

Improper use of this sprayer or handling of chemicals could result in serious injury or illness, or could cause damage to the environment.

Contents of your sprayer's carton

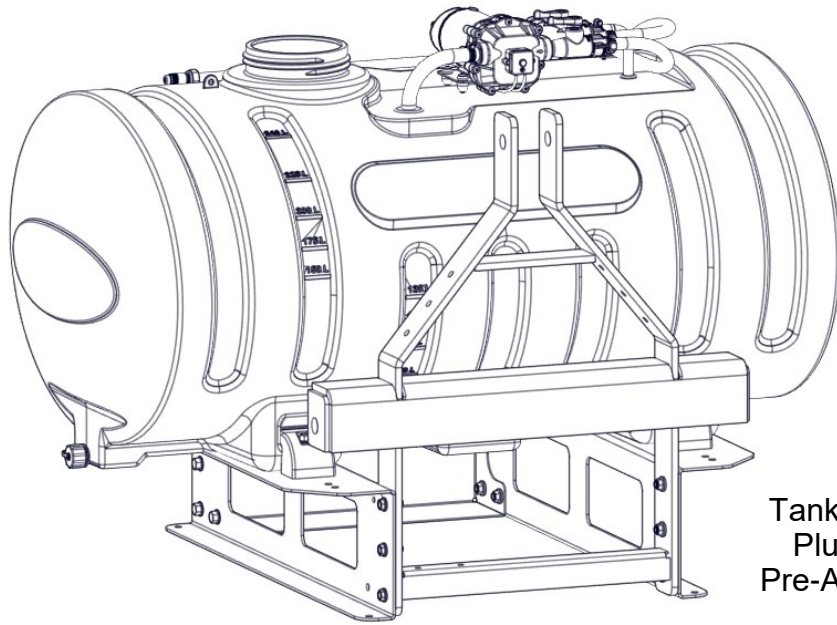

Tank/Frame/
Plumbing
Pre-Assembly

Owner's
Manual

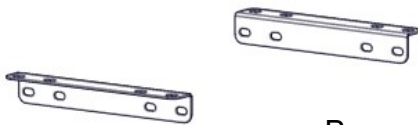

Boom Mounts



Tank Lid w/Lanyard

Boomless Boom Assembly



65G Bolted 3PT 12V Parts Bag (5282444)

Ref. #	Part #	Description	Qty
1	5278114	Lead Wire Assembly w/15A Fuse (96" Long)	1
2	5133276	Hose Wrap	2
3	5117234	#10-24 x 0.50 PH Truss Head Screw	4
4	5034634	5/16-18 x 0.625 Flng Hex Bolt	4
5	5167007	Pressure Gauge, 0-100 p.s.i.	1
6	5006307	5/16-18 Serrated Flng Hex Nut	8

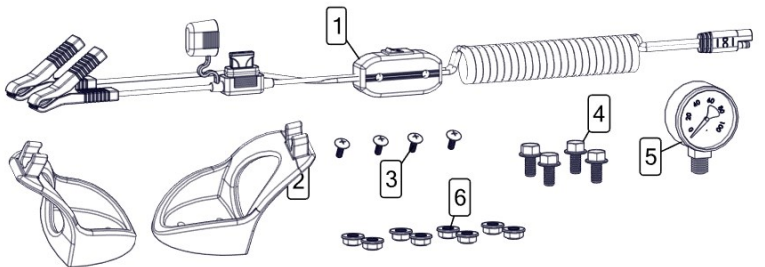

Bolted 3PT Round Boom Parts Bag (#5282443)

Ref. #	Part #	Description	Qty
1	5051114	Hose Clamp (1/2")	1
2	5034220	5/16-18 x 1.3125 x 1.75 Round U-Bolt	2
3	5101294	Lift Arm Pin - Cat 1	2

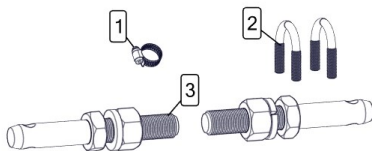

Assembly Instructions:

Assembly Instructions

Your sprayer has been mostly assembled at the factory.

Remove all parts from the box and follow the instructions on pages 4 and 5 to complete assembly of this unit.

Step 1

Attach the two boom mounts to the frame, as shown, using (4) 5/16"-18 x 5/8" Flanged Hex Bolts, (4) 5/16-18 Serrated Flanged Hex Nuts.

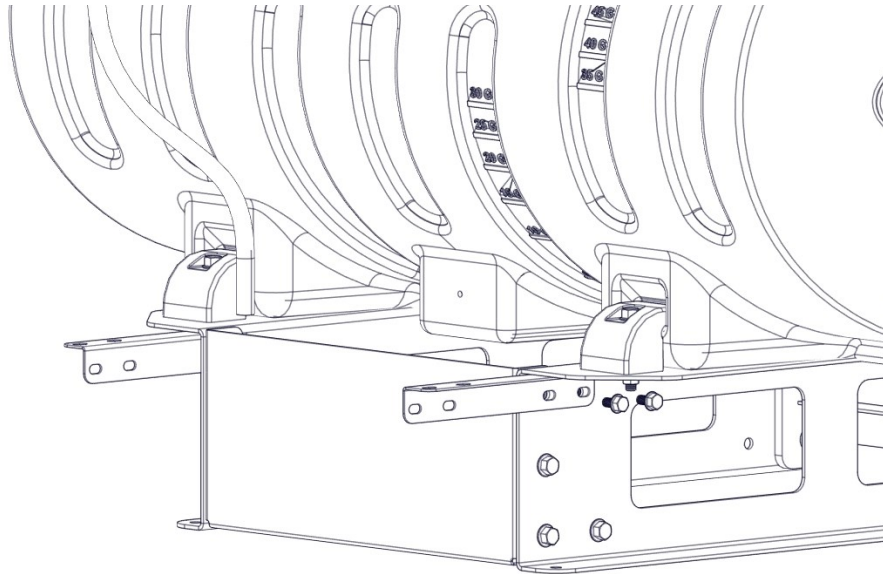

Step 2

Center the boom tube on the boom mounts and secure in place with the (2) round U-bolts and whiz nuts provided.

Make sure the U-bolts are positioned within the grooves of the grommets on the boom tube.

NOTE: The purpose of these grommets is to prevent metal-to-metal contact between the U-bolts, boom tube and boom mounting brackets.

The grommets will 'compress' as you tighten the whiz locknuts onto the U-bolts. Tighten just so that the boom tube will NOT rotate within the grommets. Alternate the tightening of the locknuts to provide even pressure on the grommet.

****DO NOT OVER TIGHTEN the whiz locknuts, as this may cause the boom tube to flatten slightly!**

See Next Page for proper end nozzle attachment.

Loosely slide a hose clamp on to the feeder hose, connect the boom feeder hose to the hose barb tee on the nozzle harness and secure with the hose clamp.

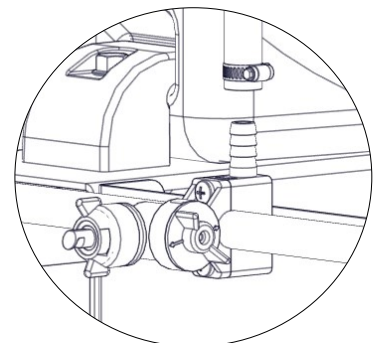
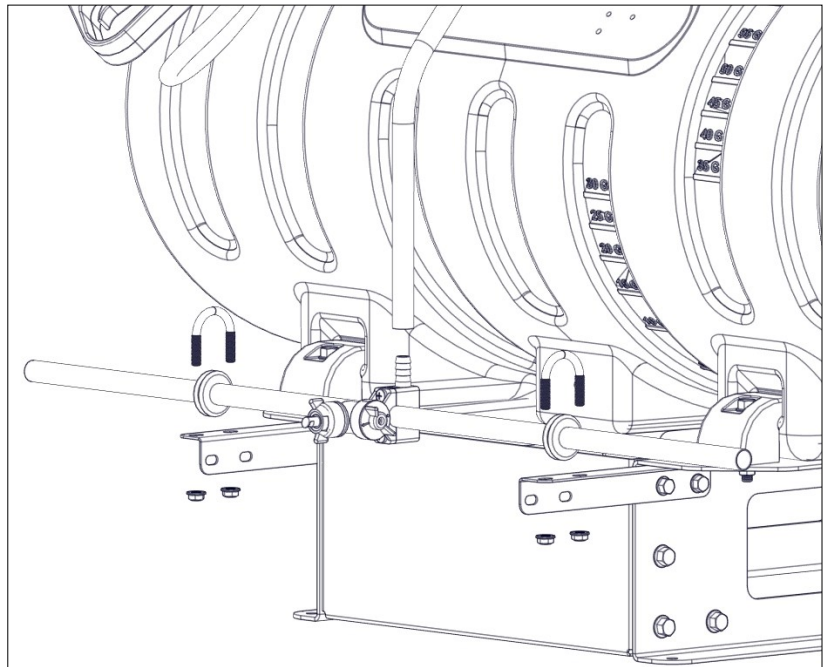

End Nozzle Assembly Procedure For Boomless "Wet" Boom

Your boom will come with the (2) end nozzle assemblies NOT affixed to your boom tube. Follow the instructions below to attach these properly to the boom tube, as shown.

Step 3

Assembled
End Nozzle

1. First REMOVE O-Ring, Item 2 (#5072517) from the end nozzle body assembly.
2. Start by sliding Item 4, 3, 2 onto the boom tube (Item 1) as shown, leaving about 1/2" to 3/4" between the end of the boom tube and Item 2. Make sure the "Long" portion of Item 3 is facing the nozzle end.
3. Slide the (complete) end nozzle assembly onto the stainless steel boom tube, with somewhat of a "twisting" motion, so that the end face of the boom tube "butts" up against the surface face inside the nozzle body.
4. Now push the "compression olive" (Item 3) against O-ring (Item 2) and slide (both) into the nozzle body opening firmly.
5. Firmly tighten flynut (Item 4) onto threads of nozzle body.

Repeat for other side.

NOTE: If water is shooting back on the boom tube, item 2 is not in the correct placement.

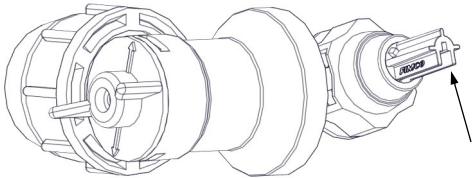
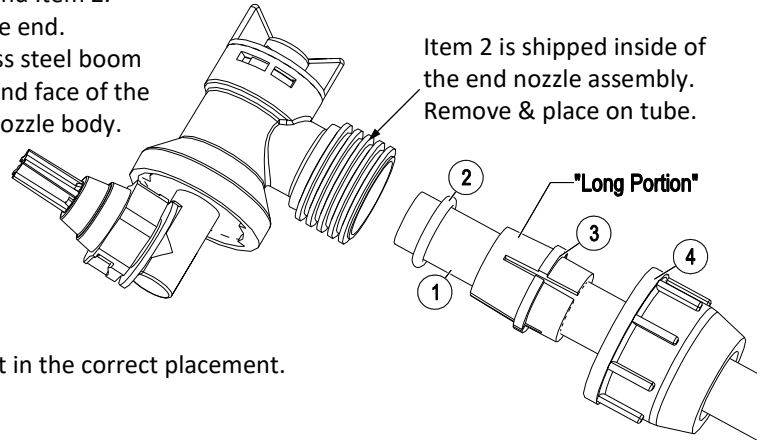

This slot needs to be facing downward in order for the nozzle to spray correctly. If it needs to be adjusted, just loosen the cap and while holding the cap, twist nozzle until it is parallel to the ground.

End Nozzle Information

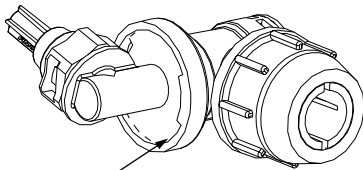

Nozzle mounting stem has a ratcheting motion.

** Each "click" of the ratcheting motion is approx. 15° **

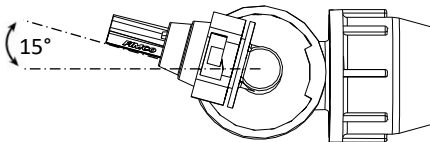

For proper/optimal spray coverage,
The nozzle must be at a 15° angle

The 15° angle shown will prevent the outer
Nozzles from overlapping with the center nozzle.

"On/Off" Valve Positions

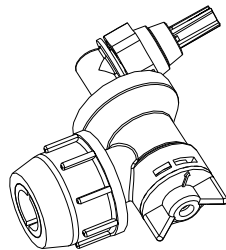

Valve "Open"

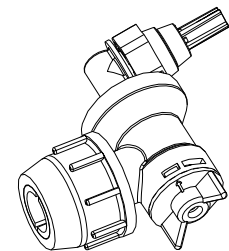

Valve "Closed"

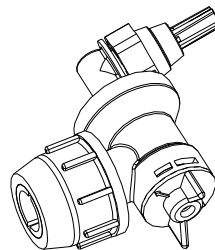

Service Position

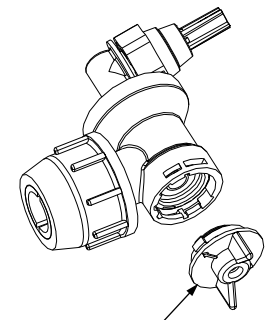

On/Off Valve Knob
Eliminate line pressure, then pull
out to check diaphragm condition.

Note: The check valve & diaphragm can fall out during transport, if the knob is not turned to the "ON" or "OFF" position.

Assembly Instructions (Cont.):

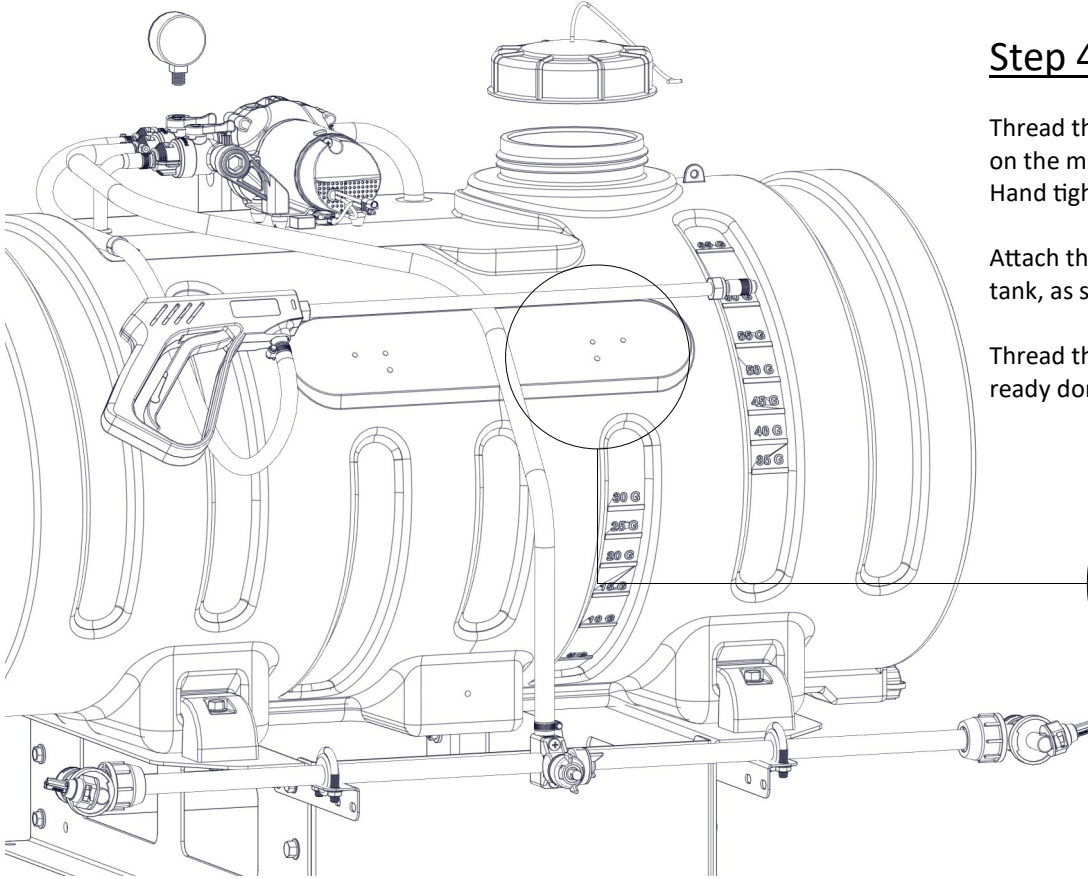

Step 4

Thread the pressure gauge into the port on the manifold.
Hand tight should be sufficient.

Attach the hose wraps to the side of the tank, as shown, with 4 screws.

Thread the lid on to the tank, if not already done.

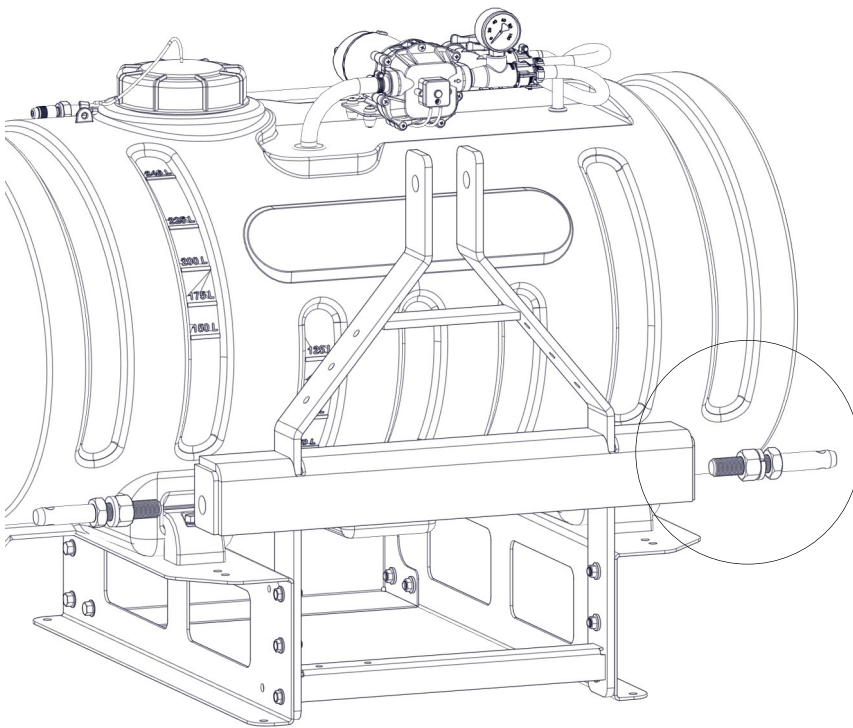
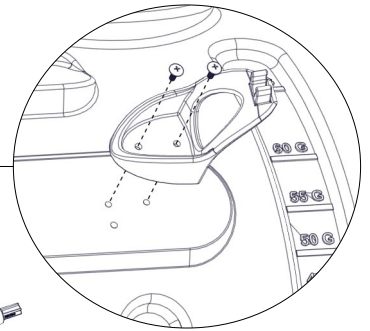

Step 5

Install the lower hitch pins into the bracket lift arm.
Place these pins through the holes in the pin plates, slip the lock washers on and thread the nuts onto the pin. Tighten securely.

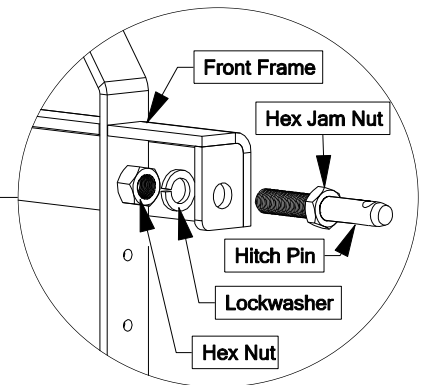

- Make sure all hose clamps are tight before testing or spraying for the first time.
- One requirement will be for you to hook up your battery leads to a fully charged 12 Volt battery.
- The drain plug assembly should already be attached to the tank

****The Sprayer is now ready to TEST w/plain water before actual use****

IMPORTANT: Remove tank lid and be sure the tank is clean and free of any foreign material. Rinse tank out of any tank residue before filling with water to test.

Testing the Sprayer

NOTE:

It is VERY important to test the sprayer with plain water before actual spraying is attempted. This will enable you to check the sprayer for leaks without the possibility of losing any expensive chemicals.

Important: After any repair work has been done, ALWAYS test for leaks with water before using.

Fill the tank about 1/2 full with plain water and drive to the starting place for spraying.

When you are ready to spray, turn the boom valve to the “on” position (Detail A). This will start solution spraying from the tips of the boom. The pressure will decrease slightly when the boom is spraying.

Adjust the pressure by turning the “ON/OFF” valve lever on the bypass (Press Adj) line valve (Detail B). Make sure your pattern is sufficient. You may down-pressure the system by ‘bypassing’ solution back into the tank. This is achieved by opening the bypass (Press Adj) valve. Regulating pressure is done in this manner.

Read the operating instructions and initially begin spraying by closing the ‘Pressure Adjust’ valve and opening the boom line valve (Detail A). This will enable the air in the line to be eliminated (purged) through all the tips, while building pressure. When everything tests all right (no leaks and good pressure), add the desired chemicals to the mixture and water combination and start your spraying operation. Adjust the pressure and spray as you did in the testing procedure.

Conditions of weather and terrain must be considered when setting the sprayer. Do not spray on windy days. Protective clothing must be worn in some cases.

Be sure to read the chemical label(s) before application!

Operation

The pumping system draws solution from the tank, through the strainer and to the pump. The pump forces the solution under pressure to the handgun or boom nozzles.

Fill the tank part way with water and then add the desired amount of chemical to be sprayed. Finish filling tank to proper level.

Only fill the tank with what you’re going to spray in a day, never leave chemicals sit in tank.

Connect the lead wire to a fully charged 12 volt battery. You may use either a stand-alone battery or the battery on your towing vehicle. Connect to the positive (red) terminal first, then connect to the negative (black) terminal. Then connect the end of the lead wire to the end of the pump. When disconnecting, disconnect the end of the pump wire from the lead wire, then disconnect the negative (black) connection and finally the positive (red) connection. The lead wire has an On/Off switch to activate the pump. “-” is on and “O” is off.

Turn the pump on by depressing the “-” side of the rocker switch. The pump is equipped with a pressure switch that is pre-set at the factory to shut the pump off when all discharges are closed. Only fill the tank with what you’re going to spray in a day, never leave chemicals sit in tank.

The pump will turn back on when one of the following actions occurs:

- ◆ Handgun lever is squeezed to spray the handgun.
- ◆ Boom valve is opened to broadcast spray with the boom.
- ◆ Bypass (Press Adj) valve is opened to re-circulate solution back into the tank.

When spraying with either the boom or the handgun, pressure may be reduced by slowly opening the bypass (Press Adj) valve until desired pressure is achieved.

Opening the valve decreases pressure, closing the valve increases pressure. When spraying with the boom, the proper method to set the pressure is to open the boom valve completely and if a lower pressure is desired, then slowly open the bypass (Press Adj) valve until that pressure is obtained.

For the safest and most efficient chemical application, you will need to calibrate your sprayer using the tip and speed charts. Once you have determined the proper speed and pressure settings, you will need to consult your chemical label for the amount of chemical to be added to the tank. Read the entire label. Use only according to label directions.

Manifold Valves CLOSED

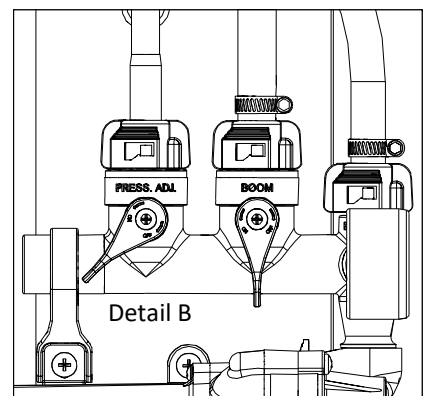
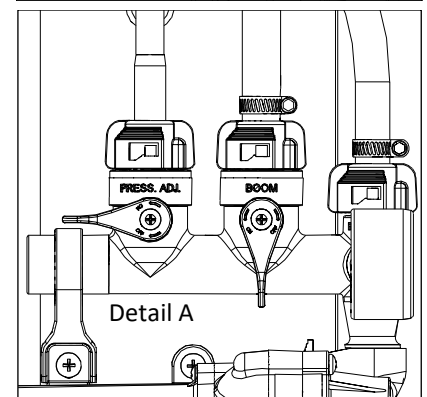
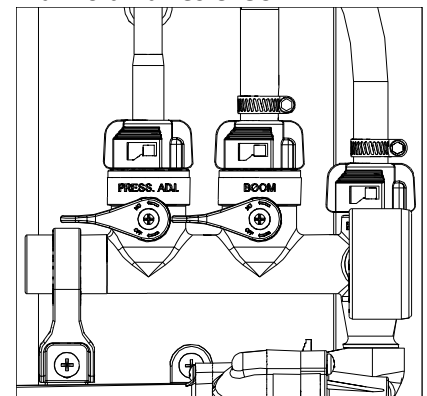

Calibration

Chemical labels may show application rates in gallons per acre, gallons per 1000 square feet or gallons per 100 square feet. You will note that the tip chart shows 3 of these rating systems. Once you know how much you are going to spray, then determine (from the tip chart) the spraying pressure (PSI), and the spraying speed (MPH).

Determining the proper speed of the pulling vehicle can be done by marking off 100, 200 & 300 feet. The speed chart indicates the number of seconds it takes to travel the distances. Set the throttle and with a running start, travel the distances. Adjust the throttle until you travel the distances in the number of seconds indicated by the speed chart. Once you have reached the throttle setting needed, mark the throttle location so you can stop and go again, returning to the same speed.

Add water and proper amount of chemical to the tank and drive to the starting place for spraying.

Note: The same figures are used for 1, 2, or 3 nozzles.									
17½" Spacing									
	Pressure (p.s.i.)	Capacity (g.p.m.) (3 nozzles)	1 MPH	2 MPH	3 MPH	4 MPH	5 MPH	6 MPH	8 MPH
Gallons Per Acre Based on Water	20	1.68	28.0	14.0	9.4	7.0	5.6	4.7	3.5
	30	2.05	34.4	17.2	11.4	8.6	6.9	5.7	4.3
	40	2.40	39.6	19.8	13.2	9.9	7.9	6.6	5.0
Gallons Per 1000 Sq. Ft. Based on Water	20	1.68	0.64	0.32	0.21	0.16	0.13	0.11	0.08
	30	2.05	0.78	0.39	0.26	0.20	0.16	0.13	0.10
	40	2.40	0.90	0.45	0.30	0.23	0.18	0.15	0.12
Gallons Per 100 Sq. Ft. Based on Water	20	1.68	0.064	0.032	0.021	0.016	0.013	0.011	0.008
	30	2.05	0.078	0.039	0.026	0.020	0.016	0.013	0.010
	40	2.40	0.090	0.045	0.030	0.023	0.018	0.015	0.012
** The rate of spray as shown in the chart will remain the same with 1 or 2 Nozzles ** The only difference will be with the width of the spray swath									

Speed Chart			
Speed in M.P.H. (Miles Per Hour)	Time Required in seconds to travel a distance of		
	100 Ft.	200 Ft.	300 Ft.
1.0	68 sec.	136	205
2.0	34	68	102
3.0	23	45	68
4.0	17	34	51
5.0	14	27	41
6.0	11	23	34
7.0	9.7	19	29
8.0	8.5	17	26
9.0	7.6	15	23
10.0	6.8	14	20

Using the Boom Nozzles

Four things must be considered before spraying with the boom.

1. How much chemical must be mixed in the tank.
2. Rate of spray (gallons per acre to be sprayed).
3. What pressure (p.s.i.) will be used.
4. Speed traveled (mph) while spraying.

- The (3) nozzles are fixed at 17-1/2" spacing
- All (3) nozzles spraying at the same time will allow a maximum coverage of 36 feet
- The center nozzle will spray an 80" swath
- Each of the (3) nozzles has a shutoff valve, so you can shut off each nozzle individually. This may help in achieving the actual coverage needed for your application.

- * Refer to the chemical label to determine your chemical mixture.
- * See the tip chart to determine the pressure to be used. The chart will also show the speed used when spraying.
- * Start the pump and open the valve to the boom nozzles.
- * Check the spray pattern. Usually you can see the coverage better on a solid concrete surface, such as a driveway.
- * Approximate height: 33"

Tank Care & Maintenance

Warning: Do not use the tank as a container for fuel oils, kerosene, gasoline or any other petroleum distillate product. All polyolefins are softened and permeated by such products. In an enclosed area the vaporization of these materials from the outside surface of the tank could create a dangerous condition.

The tank should not be used as a pressure vessel nor used with chemicals or solutions having a weight of more than 12 pounds per gallon.

Store the tank in a dry dark place when not in use. Storage out of sunlight will prolong the life of the tank.

Do not drop, strike or kick the tank, especially at low temperatures. Tanks become brittle and are subject to cracking at temperatures below 20° Fahrenheit.

Always flush the tank with water and a neutralizing agent at the end of each use, to prevent contamination of solutions.

Maintenance During/After Spraying

Periodically check the strainer and clean the screen on your intake line.

If sprayer becomes clogged during use, discontinue use immediately. DO NOT attempt to service while chemicals are in the sprayer and power is connected.

Proper care and maintenance will prolong the life of your sprayer.

After use, drain the tank and store or dispose of chemical properly. Fill the sprayer half way with clean water. Start the pump and allow the water to pump through the entire plumbing system and nozzles. Drain and then refill half full, add the recommended amount of a good quality tank cleaner, such as FIMCO Tank Neutralizer and Cleaner. (If no tank cleaner is available, you may substitute dish soap for this step, about 1-2 oz. per gallon). But a neutralizer/cleaner should be used to thoroughly clean the system and prolong the life of the sprayer. Turn pump on and circulate through system for 15 minutes and then spray out through boom and handgun nozzles. Refill sprayer half way with clean water and repeat. Follow the chemical manufacturer's disposal instructions of all wash or rinsing water.

If boom (if applicable) or handgun nozzles need cleaning, remove them from the sprayer and soak in warm soapy water. Clean with a soft bristled brush or toothpick if necessary. Never use a metal object. Even the slightest damage can change the flow rate and spray distribution. Water rinse and dry the tips before storing.

WARNING: Some chemicals will damage the pump valves if allowed to soak untreated for a length of time! ALWAYS flush the pump as instructed after each use. DO NOT allow chemicals to sit in the pump for extended times of idleness. Follow the chemical manufacturer's instructions on disposal of all waste water from the sprayer.

Winter Storage

Prepare the sprayer for end-of-season storage by running RV antifreeze through the system. This will keep internal parts lubricated, protect against corrosion and keep the unit from freezing. *Note: RV antifreeze is non-toxic and biodegradable and generally safer for the environment than automotive antifreeze.*

Before storing your sprayer for winter or long term storage, thoroughly clean and drain it as much as possible. Then pour enough pink RV antifreeze into the tank so that when the pump is turned on you can pump the antifreeze throughout the entire plumbing system, including the bypass. Make sure to operate the boom and handgun until you see pink fluid spraying from the nozzles. Leave any remaining antifreeze in the tank. Before your next usage, rinse the antifreeze from the sprayer with clean water.

It is nearly impossible to drain all of the water from the sprayer and any trapped water can freeze in cold weather and damage parts of the sprayer. Pumping the antifreeze through the system will displace the water and help prevent this damage.

Removing from storage: drain the antifreeze. Fill the tank with fresh water and run through the system. Dispose of antifreeze and flush water properly.

Before Troubleshooting or Attempting to Service the Pump:

- ◆ **Review Troubleshooting Chart:** Do Not attempt to repair until steps below are followed.
- ◆ **Personal Protective Gear:** Wear protective gear when servicing pump.
- ◆ **Disconnect Power:** Disconnect the power to the pump and relieve the pressure from the system.
- ◆ **Empty and Flush** the pump system with water, never attempt to service the pump until it has been emptied and flushed.
- ◆ **Perform Repairs:** Follow directions provided in the troubleshooting section to repair the pump.
- ◆ **Test:** Always test the pump for leaks with plain water after any repairs before using.

Sprayer and Pump FAQs:

- ◆ **Why does the pump not run all the time?** This is an on-demand pump and only runs when a discharge is open (spray gun, bypass, boom (if applicable) or a leak is in the system).
 - ◆ **Why does the pump surge while using the spray gun?** Low flow/high pressure may cause the pump to surge (or cycle). Typically the spray wand is adjusted at too fine of a mist, to overcome, adjust the nozzle for a higher flow.
 - ▣ **How do I adjust the pressure?** Pressure can only be adjusted by opening the pressure adjust (bypass) valve to allow some of your water or solution to return to the tank (if equipped).
 - ◆ **Pump quit and will not run, what do I need to do?** Squeeze trigger on spray gun to ensure that the system isn't just pressurized up with discharges closed. Check electrical connections, ensure switch is on. Check fuses. Check for proper voltage. Check pressure switch.
 - ◆ **Low flow or no flow at all, what do I need to check for?** Check for a clogged or kinked intake hose and/or clogged intake strainer. Check for proper voltage. You will need to occasionally check your intake strainer to ensure that it is clean of any debris.
 - ◆ **What is causing the fuse to blow each time I turn the pump on?** Check for excessive voltage. Improper adjustment of the pressure switch. Damaged or defective wire harness or defective pressure switch.
- Warning:** Ensure the wiring harness does not become pinched or damaged in any way. This may damage the pump or cause the wiring harness to overheat, resulting in a melt down or fire.

STOP WARNING STOP

DO NOT USE PUMP IN AN EXPLOSIVE ENVIRONMENT. DO NOT USE TO PUMP FLAMMABLE/COMBUSTIBLE FLUIDS, GASOLINE, KEROSENE, FUEL, OIL, ETC.

HIGH FLO

HIGH PERFORMANCE

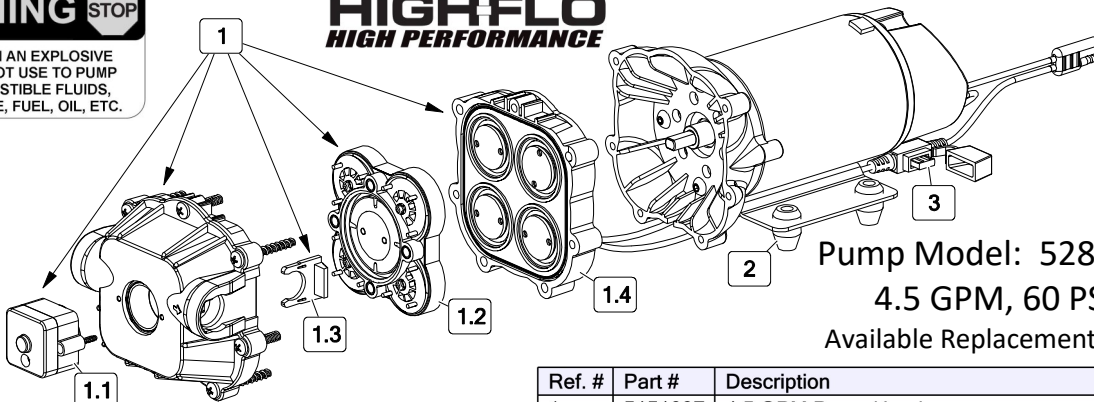

Pump Model: 5281372
4.5 GPM, 60 PSI
Available Replacement Parts

Replacement Pump: 5151088

Includes:
1/2" MNPT Port Kit Fitting #5168832
1/2" Hose Barb Port Kit Fitting #5168833

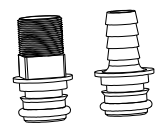

Ref. #	Part #	Description	Qty
1	5151097	4.5 GPM Pump Head	1
1.1	5164271	60 PSI Pressure Switch	1
1.2	5168824	Check Valve w/O-Ring	1
1.3	5051162	Pump Slide Clips (Pkg/2)	1
1.4	5063271	4.5 GPM Diaphragm/Piston/Cam/Bearing Kit	1
2	5075019	Grommets (Pkg/4)	1
3	5157206	15 Amp 'Mini Blade' Fuse	1

▲▲ CAUTION ▲▲

PRESSURE SWITCH OPERATION
Pressure switch is pre-set at the factory. Improper adjustment of the pressure switch, may cause severe overload or premature failure. If the pump is subjected to rapid cycling during normal operation, or infrequent periods, damage may occur.



- Clean and rinse your pump after each use with Fimco Tank Neutralizer.
- Winterize your pump or sprayer by rinsing, draining and running RV Antifreeze through it before storing for the winter.
- Use clean water for your spray mixture.
- Store inside a building when not in use.



- Use to pump bleach.
- Use to pump petroleum products such as diesel fuel, gasoline or kerosene.
- Use to pump chemicals w/petroleum distillates or surfactants.
- Use to store flammable or combustible liquids.
- Leave your pump sit with spray mixture in it for extended periods.
- Use dirty or unfiltered water for spraying.

Troubleshooting

Pump will not run:	Check for loose wiring	Pump surges:	Low flow may cause pump to surge	
	Make sure the ON/OFF switch is on		Spray Wand is adjusted to small or fine of a spray pattern	
	Check the fuse		Check for defective pressure switch	
	Check for defective pressure switch		Check for leaks in the discharge line	
	Check to see if connected to good 12 Volt Power Source		Check for debris in nozzle orifice	
	Check for Low Voltage		Discharge hose may be too long	
Pump Does Not Prime (No Discharge w/Motor Running)	Check for clogged strainer/filter	Pump continues to run:	Check for clogged strainer/filter	
	Check for kinked inlet/outlet hoses		Check for worn or dirty check valve	
	Check for empty product supply		Slightly open bypass (if applicable) to overcome Pressure switch may need to be adjusted 1/4 turn at a time clockwise until surging stops	
	Check for defective check valve		Fuse blows:	Check for worn or dirty check valve
	Check for debris in the check valve assembly			Check for empty product supply
	Check for cracks in the pump housing			Check for Low Voltage
Low Pressure/ Low Flow:	Check for air leaks in supply line	Pump continues to run:	Check for leaks in the discharge line	
	Check for a clogged strainer		Check for defective pressure switch	
	Check for proper voltage Try another 12-Volt battery		System has leaks	
	Check for leaks in the discharge line		Air trapped in outlet line or pump head	
	Check for restrictions in the discharge line		Fuse blows:	Excessive voltage
	Check for debris in intake			Improper adjustment of pressure switch
Check for debris in nozzle orifice	Damaged or defective wiring harness			
	Check for worn or dirty check valve	Defective pressure switch		

Motor is NOT Running - Checking the Pressure Switch:

If motor is not running and you've checked the following: for loose wiring connections, fuse, switch on lead wire was "ON" and made sure you were connected to a fully charged battery but the motor won't run, then it's time to check to see if the pressure switch is bad.

- Remove the cover off the 1" square box (pressure switch) on the head of the pump, the cover is held on by one phillips-head screw. This will expose the two red wires.
- With the pump connected to a good 12 volt power source and everything on.
- Slip the two red wires off the terminals and touch them together.

- ◆ If motor runs, it means the pressure switch is bad and needs to be replaced.
- ◆ If motor still doesn't run, try bypassing the switch in the lead wire or using another lead wire. Even if a tester shows power to the pressure switch, still try this test.

Warning: It is NOT recommended to run the pump this way, as the pump will continue to run and not shut off.

This could result in blown hoses when all discharges are closed or premature failure of the pump completely.

Motor Running-No Pressure - - Cleaning the Check Valve:

Experiencing little to no pressure or pump is not priming and filter screen is clean and plumbing is good with no leaks, you may need to clean the check valve.

- Remove the head of the pump, which is held on by 7 screws.
- First part inside the head of the pump is the check valve, this part responsible for building up pressure and pumping water/solution through the lines.
- Clean the check valve under hot, soapy water (such as a good grade dish soap).
- Lightly scrub, if needed, with something like an old toothbrush, something with soft bristles.
- Let soak for about an hour or so in the hot soapy solution, replace in the pump and reassemble.

Most times this will restore most, if not all of the prime of a pump.

If still having issues with pressure after this step, it would be recommended to replace this part.

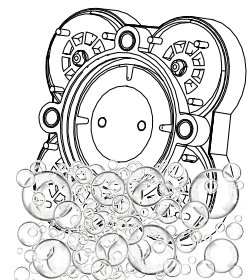
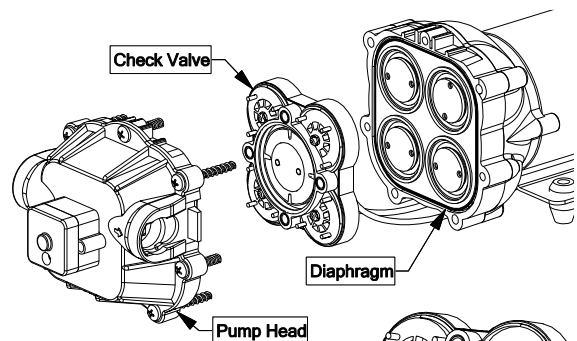
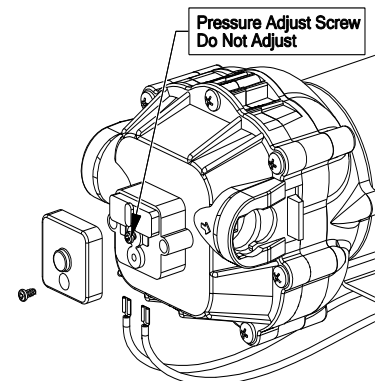

Exploded View/Parts List: 3PT-65-12V-BL (5303251)

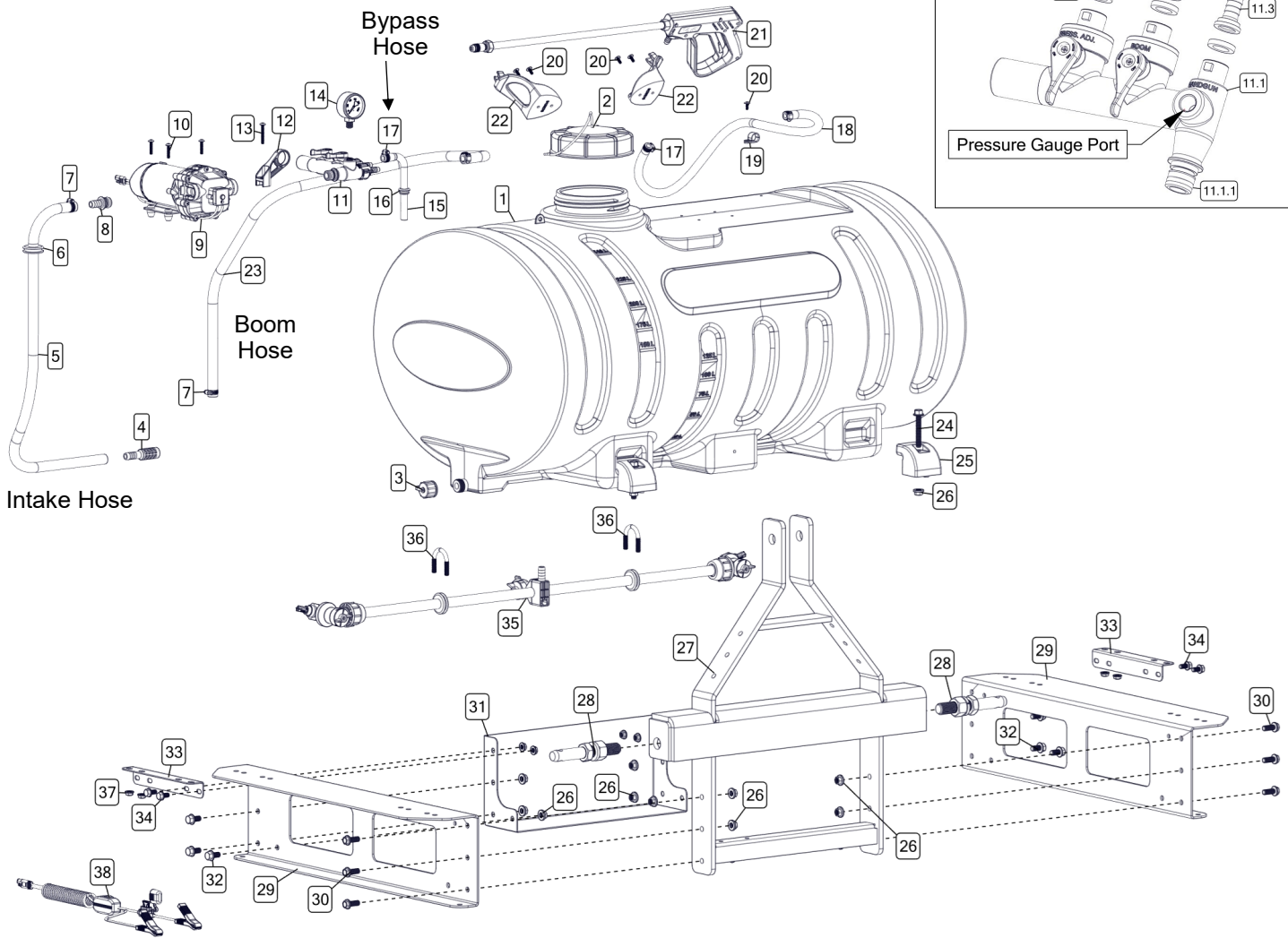
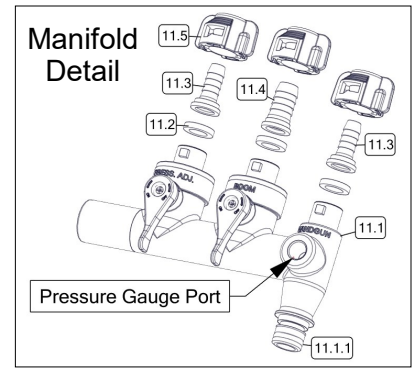

Ref. #	Part #	Description	Qty
1	5169361	65 Gallon Elliptical Tank	1
2	5058188	Tank Lid w/Lanyard	1
3	5274373	Drain Plug Cap Assembly	1
4	5116477	1/2" Hose Barb Suction Strainer	1
5	5020028	Hose 1/2"-1 Brd. x 33"	1
6	5075016	Rubber Grommet	1
7	5051114	Hose Clamp (1/2")	3
8	5168833	1/2" Hose Barb Port Fitting	1
9	5281372	4.5 GPM Pump, 60 PSI	1
10	5117168	#10-24 x 1.00 PH Truss Head Screw	3
11	5281541	Quick Connect Manifold Assembly	1
11.1	5302347	Quick Connect Manifold (Main Body)	1
11.1.1	5072514	O-Ring - Pump Port Connection	1
11.2	5143430	Flat Washer - Hose Barb Seal	3
11.3	5143431	QC Manifold - 3/8" Hose Straight Barb	2
11.4	5143432	QC Manifold - 1/2" Hose Straight Barb	1
11.5	5143429	Quick Connect Quarter Turn Cap	3
12	5143422	QC Manifold - Support Bracket	1
13	5117338	#10-24 x 1.50 PH Truss Head Screw	1
14	5167007	Pressure Gauge, 0-100 p.s.i.	1
15	5100961	Formed Bypass Tube	1
16	5075018	Grommet	1
17	5051144	Hose Clamp (3/8")	3
18	5020527	Hose, 3/8"-1 Brd. x 25 Ft.	1

Ref. #	Part #	Description	Qty
19	5051122	5/8" Black Nylon Loom Cable Clamp	1
20	5117234	#10-24 x 0.50 PH Truss Head Screw	5
21	5273959	Deluxe Pistol-Grip Handgun w/X-26 Tip	1
21.1	5018331	Brass Handgun Tip (X-26)	1
22	5133276	Hose Wrap	2
23	5020506	Hose, 1/2"-1 Brd. x 42"	1
24	5034667	3/8-16 x 2.50 Fing Hex Bolt (Full Thread)	4
25	5095990	Tank Clamp	4
26	5006259	3/8-16 Serrated Fing Hex Nut	16
27	5282446-RED	65G 3PT Front Frame	1
28	5101294	Lift Arm Pin - Cat 1	2
29	5070187-RED	65G 3PT Side Frame	2
30	5117307	3/8-16 x 1.00 Fing Hex Bolt	6
31	5282445-RED	Back Plate	1
32	5034660	3/8-16 x 0.75 Fing Hex Bolt	6
33	5095993-BLK	Boom Mount	2
34	5034634	5/16-18 x 0.625 Fing Hex Bolt	4
35	5275260	"Wet Boom" Assembly	1
36	5034220	5/16-18 x 1.3125 x 1.75 Round U-Bolt	2
37	5006307	5/16-18 Serrated Fing Hex Nut	8
38	5278114	Lead Wire w/15A Fuse (96" Long)	1
38.1	5157238	15 Amp Regular Blade Fuse	1

Boomless "Wet" Boom Assembly
Exploded View/Parts List (5275260)

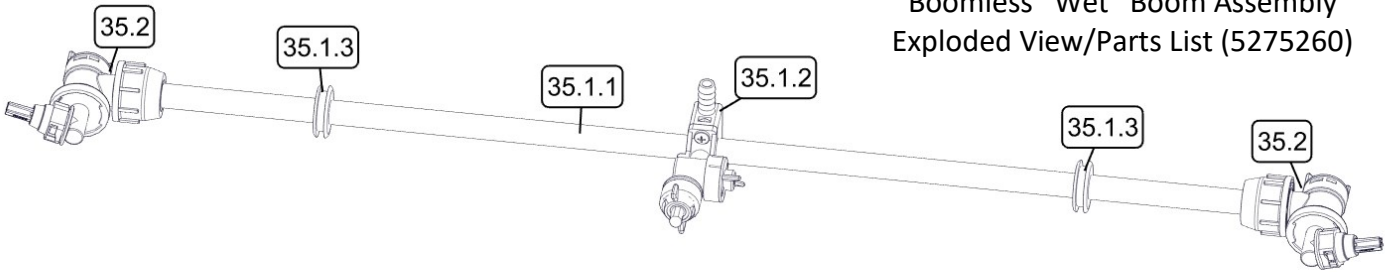

Ref. #	Part #	Description	Qty
35	5275260	"Wet Boom" Assembly	1
35.1	5275712	Wet Boom Sub-Assembly	1
35.1.1	5100316	Boom Tube	1
35.1.2	5275123	Center Nozzle Assembly	1
35.1.2.1	5274862	Center Nozzle Cap w/Gasket	1
35.1.2.2	5018329	Center Spray Tip	1
35.1.2.3	5088024	Valve (On/Off) Knob w/Diaphragm	1

Ref. #	Part #	Description	Qty
35.1.2.3.1	5063255	Diaphragm	1
35.1.3	5075016	Rubber Grommet	2
35.2	5275122	End Nozzle Assembly	2
35.2.1	5274861	XT Spray Nozzle, Cap, & O-Ring	1
35.2.2	5088024	Valve (On/Off) Knob w/Diaphragm	1
35.2.2.1	5063255	Diaphragm	1

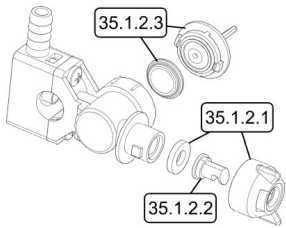

Center Nozzle Assembly

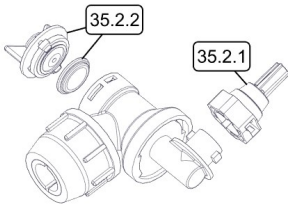

End Nozzle Assembly

Dimensions

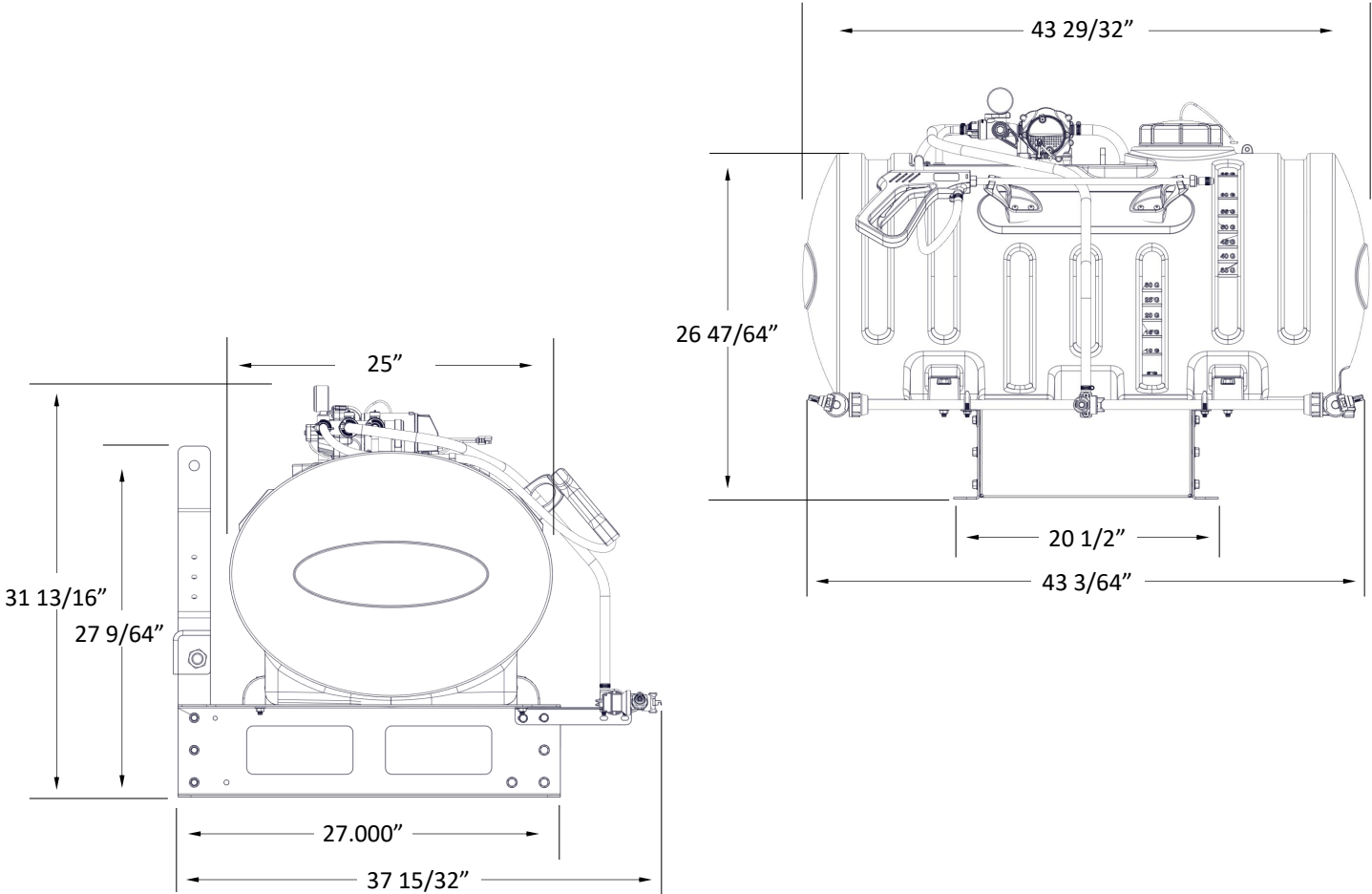

Warranty

LIMITED WARRANTY FOR NEW FIMCO, IND. EQUIPMENT

WHO MAY USE THIS LIMITED WARRANTY. This limited warranty (the "Limited Warranty") is provided by Fimco, Ind. to the original purchaser ("you") of the Equipment (as defined below) from Fimco, Ind. or one of Fimco, Ind.'s authorized dealers. This Limited Warranty does not apply to any subsequent owner or other transferee of the Equipment. THIS LIMITED WARRANTY GIVES YOU SPECIFIC LEGAL RIGHTS, AND YOU MAY ALSO HAVE OTHER RIGHTS WHICH VARY FROM STATE TO STATE.

WHAT THIS LIMITED WARRANTY COVERS AND FOR HOW LONG. Fimco, Ind. warrants that any new Equipment will be free from defects in material and workmanship for a period of **one (1) year** for sprayer and **two (2) years** for High-Flo High Performance pump (homeowner), **90 days** for sprayer and pump (commercial user), after delivery of the Equipment to you (the "Warranty Period"). The Warranty Period is not extended if Fimco, Ind. repairs or replaces the Equipment.

WHAT IS NOT COVERED BY THIS LIMITED WARRANTY. This Limited Warranty does not apply to: (1) used Equipment; (2) any Equipment that has been altered, changed, repaired or treated since its delivery to you, other than by Fimco, Ind. or its authorized dealers; (3) damage or depreciation due to normal wear and tear; (4) defects or damage due to failure to follow Fimco, Ind.'s operator's manual, specifications or other written instructions, or improper storage, operation, maintenance, application or installation of parts; (5) defects or damage due to misuse, accident or neglect, "acts of God" or other events beyond Fimco, Ind.'s reasonable control; (6) accessories, attachments, tools or parts that were not manufactured by Fimco, Ind., whether or not sold or operated with the Equipment; or (7) rubber parts, such as tires, hoses and grommets.

HOW TO OBTAIN WARRANTY SERVICE. To obtain warranty service under this Limited Warranty, you must (1) provide written notice to Fimco, Ind. of the defect during the Warranty Period and within **thirty (30) days** after the defect becomes apparent or the repair becomes necessary, at the following address: Fimco, Ind., 1000 Fimco Lane, North Sioux City, SD 57049; and (2) make the Equipment available to Fimco, Ind. or an authorized dealer within a reasonable period of time. For more information about this Limited Warranty, please call: **800-831-0027**.

WHAT REMEDIES ARE AVAILABLE UNDER THIS LIMITED WARRANTY. If the conditions set forth above are fulfilled and the Equipment or any part thereof is found to be defective, Fimco, Ind. shall, at its own cost, and at its option, either repair or replace the defective Equipment or part. Fimco, Ind. will pay for shipping and handling fees to return the repaired or replacement Equipment or part to you.

LIMITATION OF IMPLIED WARRANTIES AND OTHER REMEDIES. THE REMEDIES DESCRIBED ABOVE ARE YOUR SOLE AND EXCLUSIVE REMEDIES, AND FIMCO, IND.'S SOLE LIABILITY, FOR ANY BREACH OF THIS LIMITED WARRANTY. TO THE EXTENT APPLICABLE, ANY IMPLIED WARRANTIES, INCLUDING, WITHOUT LIMITATION, THE IMPLIED WARRANTIES OF MERCHANTABILITY AND FITNESS FOR A PARTICULAR PURPOSE, SHALL BE LIMITED IN DURATION TO THE WARRANTY PERIOD, AND THE REMEDIES AVAILABLE FOR BREACH THEREOF SHALL BE LIMITED TO THE REMEDIES AVAILABLE UNDER THIS EXPRESS LIMITED WARRANTY. SOME STATES DO NOT ALLOW LIMITATIONS ON HOW LONG AN IMPLIED WARRANTY LASTS, SO THE ABOVE LIMITATION MAY NOT APPLY TO YOU. IN NO EVENT SHALL FIMCO, IND.'S LIABILITY UNDER THIS LIMITED WARRANTY EXCEED THE ACTUAL AMOUNT PAID BY YOU FOR THE DEFECTIVE EQUIPMENT, NOR SHALL FIMCO, IND. BE LIABLE, UNDER ANY CIRCUMSTANCES, FOR ANY CONSEQUENTIAL, INCIDENTAL, SPECIAL OR PUNITIVE DAMAGES OR LOSSES, WHETHER DIRECT OR INDIRECT. SOME STATES DO NOT ALLOW THE EXCLUSION OR LIMITATION OF INCIDENTAL OR CONSEQUENTIAL DAMAGES, SO THE ABOVE LIMITATION OR EXCLUSION MAY NOT APPLY TO YOU.