



**Operating manual
for multifunctional instrument**

motoscope mini - starting at serial no. 00002084

Suchen Sie die deutsche Bedienungsanleitung?

<http://motogadget.com/de/digitalinstrumente/digitaltacho-mini/downloads.html>

ABE
KBA 91177



00000269

HW V1.2

SW V1.37

Version 2.3k

Thank you very much for purchasing a high quality product from *motogadget*.

Please read the following information and recommendations carefully and follow these instructions for installation and usage of the instrument. No liability is assumed by *motogadget* for damage or defects resulting from negligence or failure due to following the operating manual.

CAUTION FOR ALL U.S. CUSTOMERS

**THIS PRODUCT IS NOT D.O.T. APPROVED AND INTENDED FOR
SHOW USE ONLY!**

**CAUTION: IF YOU ARE NOT A CERTIFIED MOTORCYCLE
TECHNICIAN PLEASE STOP HERE AND ASK YOUR LOCAL
MOTORCYCLE SHOP FOR PROFESSIONAL INSTALLATION!**

**For further product information e.g. measurements, 2D or 3D drawings,
surveys, TÜV approval, etc. visit:**

www.motogadget.de/en/msm_files.html

Contact:

motogadget GmbH
Köpenicker Str. 145
D-10997 Berlin
Germany

Fon +49 (0)30 - 69 00 410 - 0
Fax +49 (0)30 - 69 00 410 - 22

www.motogadget.com
info@motogadget.de

© Copyright and all further rights by motogadget, Berlin 2006-2014
motoscope and motogadget are registered trademarks of motogadget GmbH, Berlin, Germany

1 Review of delivery

All products from *motogadget* are thoroughly checked to ensure that they are faultless when dispatched. Please check received goods for possible transport damage. If you find any damage or other deficiencies please contact us immediately.

For returns or replacements we refer to our general terms of business and delivery published on www.motogadget.com. Should we agree to a return or replacements of the instrument please note that we only accept goods in their original packaging. The instrument and accessories must be returned within the legal time limit and without any traces of use. We do not assume any liability for returns which are insufficiently insured or packaged.

2 Exclusion of liability

INSTRUMENT CASINGS AND ALL OTHER PARTS MUST NOT BE OPENED OR DISMANTLED. IN CASE OF NON-COMPLIANCE ALL WARRANTY CLAIMS BECOME INVALID. THE USAGE OF INSTRUMENTS, SENSORS AND ACCESSORY PARTS FOR RACING OR OTHER COMPETITIONS, AS WELL AS USAGE WHICH DOES NOT COMPLY WITH RECOMMENDED APPLICATION RENDERS ALL WARRANTY CLAIMS INVALID. MOTOGADGET ACCEPTS NO LIABILITY FOR DIRECT OR INDIRECT DAMAGE OR SUBSEQUENT DAMAGE OF ANY KIND RESULTING FROM USAGE, INSTALLATION OR CONNECTION OF INSTRUMENTS, SENSORS OR OTHER DELIVERED EQUIPMENT. THIS EXCLUSION OF LIABILITY INCLUDES DAMAGE TO PEOPLE, DAMAGE TO MATERIAL AND FINANCIAL DAMAGE. USAGE ON PUBLIC ROADS IS UNDERTAKEN AT USER'S OWN RISK.

2.1 Duty of registration

The *motoscope mini* has a General Operating Permit (ABE) and therefore does not have to be entered into the vehicle documents. The device is identifiable as having a General Operating Permit by a special label with the code "KBA 91177" on the back side of the device.

THE GENERAL OPERATING PERMIT (ABE) IS ONLY VALID WHEN THE DEVICE IS INSTALLED IN TWO- OR THREE-WHEELED VEHICLES AND THE WHEEL CIRCUMFERENCE WHICH HAS BEEN ENTERED INTO SETUP CORRESPONDS TO THE ROLLING TIRE CIRCUMFERENCE GIVEN (TABLE IN APPENDIX).

THE USER IS PERSONALLY RESPONSIBLE FOR CORRECT CALCULATIONS AND ADJUSTMENTS CONCERNING TIRE CIRCUMFERENCE, IMPULSES PER WHEEL ROTATION AND CORRECT INSTALLATION OF THE SPEEDOMETER SENSOR.

3 Technical data and functions

length/width/height	59 mm/21,5 mm/13 mm
weight without cables	ca. 32 gr.
mounting holes	2 x M3, 5 mm deep
operating voltage	9-18 V
current consumption	max. 100 mA
operating temperature	-20 – +80 °C

3.1 Summary of functions

Function	Measurement range
speedometer	0–999 km/h or mi/h
trip odometer	0–999,99 km or mi
total odometer (adjustable)	0–99999 km or mi
trip time	0–99:99 h:m
rev counter (digit read out)	0–20,000 rpm
rev counter as LED bar	0–20,000 rpm
rpm threshold LED (shift light)	0–20,000 rpm

4 Preparation for installation and connection of the instrument

4.1 Required knowledge and abilities

Installing and connecting the *motoscope mini* and its additional equipment requires no specialist knowledge. Because the *motoscope mini* can be installed on a wide range of vehicles with different specifications and equipment it is not possible to cover all cases in this manual. In case of doubt please consult our web site (Support and FAQ). *Motoscope mini* might also be installed by a garage.

4.2 Required equipment for installation and connection

Since the *motoscope mini* is suitable for a variety of vehicles additional equipment might be required to mount the instrument to a particular vehicle, for example:

- mounting bracket for instrument plus fitting screws
- mounting bracket for speedometer sensor and push button
- cables or cable extensions for power supply, ignition signal and push button connection
- assembly equipment such as cable ties, plug connectors, shrink tubing, soldering iron, solder etc.

We recommend use of wiring diagrams for electrical connection.

If you don't use the *motogadget* all-purpose bracket you will need a stable mounting bracket for the instrument. The speedometer sensor is already equipped with a connecting cable (length 1.5 meters) so that the sensor can be connected to the front or rear wheel. For positioning of the speedometer sensor you might – depending on the position – also require a self-made holding bracket.

5 Quick start

This section provides a guide to quick installation and connection of the *motoscope mini*

- a) Have all the required equipment like mounting brackets, push buttons, fitting screws and nuts, screw adhesive (medium-strength), cables, cable ties, plug connectors, shrink tubing and soldering tin ready before you start. Tools required are screwdrivers, wrenches, an Allen key for M3 metric Allen screws, a side cutter, small pliers, soldering iron, a voltmeter and a crimping tool.
- b) Make sure that you have got the wiring diagrams of your vehicle and of the *motoscope mini* (see appendix).
- c) Choose suitable positions for installing the *motoscope mini* and the speedometer sensor. Attach the *motogadget* mounting bracket to your vehicle or make your own bracket. Attach the speedometer sensor bracket.
- d) Decide at which point all wires will be brought together in order to connect the *motoscope mini* with the power supply, speedometer sensor, ignition signal cable and the push button. Make sure there is sufficient space for the connections.
- e) Mount the instrument, the speedometer sensor and the push button to the vehicle.
- f) Locate "switched plus" on the wiring of your vehicle by using a voltmeter ("switched plus" means electricity only flows when ignition is switched on). Connect the delivered cable fuse to switched plus and route a wire from the other end of the fuse to the chosen terminal point.
- g) Remove ground cable from battery terminal.
- h) Connect a wire to the negative terminal of the ignition coil (coil terminal no 1 - which leads to ignition box) and route the wire to the terminal point you have chosen in step c).

In case of a CDI ignition = Capacitor Discharge Ignition (used for quad, scooter, trail bikes) you must use a motogadget ignition signal pickup unit (article no 3000001)
- i) Connect all wires which meet in the terminal point (*motoscope*, power supply, speed sensor, ignition coil and push button) according to the circuit diagram provided in the appendix. Use the delivered connector kit for easy unplug of the instrument if necessary.
- j) Re-connect vehicle battery and switch ignition on.
- k) Navigate to the setup menu (see Chapter 12) and adjust all necessary parameters for engine speed, the rev. counter scale and the speedometer.
- l) Start the engine and watch the rev. counter. If it works correctly, ride carefully and slowly for a while and check the speedometer. If you do not detect any electrical or mechanical problems continue the test drive.

6 General safety instructions for mounting and connection

- Disconnect vehicle battery prior to installation.
- In the interest of your own and other peoples' safety attach all parts securely to your vehicle.
- Make sure that your vehicle is equipped with **interference suppressing spark plugs and connector cables!** Use of the *motoscope mini* with non-suppressed ignition systems can lead to serious damage of the device.

7 Installation of the *motoscope mini*

To ensure correct fastening two metric fastening screws must be used (M3). In order to avoid distortions of the thread, the fastening bolts must be screwed into the instrument casing to a minimum depth of 3 mm and a maximum depth of 5 mm. Choose screws that fit to the mounting bracket. We also recommend the use of additional washers and screw adhesive (e.g. Loctite medium-strength). Furthermore, the **maximum torque** applied to the M3 fastening screws must not exceed **2 Nm**.

8 Connecting the *motoscope mini*

8.1 Recommendations for wiring

Before connecting wires look for suitable cable paths. The cables should be as far away as possible from hot engine parts. Look for a suitable place to connect wires and plugs. Similar connection points can already be found at the headlights, underneath the gas tank or at the dash board. Make sure you take note of required lengths of cables before cutting them to fit. It is important to consider the full lock of the handlebars as well as pitch of the front and rear suspension. All wires should be free of kinks and should not be subject to any pull and should be well isolated especially in places of mechanical wear. We recommend solder joints. For securing wires we recommend cable ties made from plastic.

8.1.1 Cable colours, functions, and connections

<i>motoscope mini</i>		
Cable colour	Function	Connection
Red	Power supply	Plus (+) "switched" and 1A fused voltage of the wiring harness
Black	Power supply	Minus (vehicle earth)
Yellow	Signal cable of the rev. counter THIS WIRE MUST NEVER BE CONNECTED TO THE HIGH-VOLTAGE PARTS OF THE IGNITION!	Leads to the negative pole (clamp 1 or -) at one ignition coil. <i>In case of a CDI ignition you must use motogadget ignition signal pickup unit (article no 9000001)</i>
White	Connection of the <i>motoscope</i> to the speed sensor	Leads to the signal cable of the OEM speed sensor, or delivered sensor that switched to earth
Green	Cable for the menu push button	Leads to the push button that switches to earth
Blue	No function	Not connected

8.2 Battery and power supply

The *motoscope mini* requires "switched plus" for the power supply that means electricity will only flow if the ignition is switched on. The *motoscope mini* can operate within a voltage range of 7 V to 18 V DC. Using the instrument without a vehicle battery is not intended or recommended! Please ensure that the polarity of the power supply is correct.

Caution! *You must fuse the +12 V power supply cable with the delivered 1A cable fuse. If the instrument is used without fuse, damage to the connection cable or the motoscope can cause a short circuit and a cable fire. Caution! Your life might be in danger! If you don't have the specialist knowledge required please ask a garage to install the motoscope!*

9 Installation and connection of sensors and push button

9.1 The push button

A push button is required to operate the instrument. Connect one of the push button terminals to the green *motoscope mini* wire and the other one to vehicle earth. Polarity of the push button is not relevant (see diagram in Chapter 16.1).

9.2 Rev counter sensor cable

The instrument can be connected to all conventional ignition systems that work with ignition coils. Connect the yellow cable to the negative terminal of one ignition coil or to the corresponding terminal of the ignition box [clamp 1 or earth].

In case of a CDI ignition (Capacitor Discharge Ignition - used for quad, scooter, trail bike) you must use the motogadget ignition signal pickup unit (article no 9000001)

We assume that your vehicle is equipped with an interference suppressing ignition system. For accurate functioning of the instrument preferences in the set up menu of the instrument have to be changed. Please see directions in the relevant chapter.

Caution! *The rev counter connection should never be connected to the high voltage output of the ignition.*

9.3 Installation and connection of the speedometer sensor

9.3.1 Use of original speedometer sensor

If your vehicle comes with a three-wire OEM speedometer sensor which provides a ground signal, you can generally use the sensor with the instrument. The compatibility is dependent on the vehicle model. Please compare your vehicle with our compatibility list:

http://motogadget.com/media/downloads/allgemein/s_compatibility_speedo_sensors_01.pdf

Two-wire hall sensors are not compatible with the *motoscope mini*.

Connect the sensor signal cable to the white connector cable of the *motoscope*. You will have to use the supplied motogadget speedometer sensor if no speed signal is detected.

9.3.2 Use of motogadget speedometer sensor

The speedometer sensor supplied is a reed switch. For signal detection, use a suitable glue to attach one of the delivered magnets to one of the wheels. The distance between the magnet and the wheel centre is irrelevant. Mount the speedometer sensor on a mounting bracket. Make sure, there is a clearance < 2mm between sensor tip and magnet, and the two parts are in an exactly parallel position. It is critical that the tip of the reed contact is not flush with the bracket. Make sure the protrusion of the tip measures approx. 5mm.

The bracket may not be made of magnetizable materials (iron, steel, etc.), it is essential that it is made of aluminium, stainless steel or plastic. The distance between magnet and sensor should not

exceed 2mm and may not change with vehicle in operation under load. No magnetizable material (e.g. a steel screw) may pass across the sensor tip when the wheel is turning.

The maximum mounting torque of the sensor nuts is **1 Nm**. We recommend thread lock (medium strength) for secure mounting. Connect one cable of the sensor to earth and the other one to the white cable of the *motoscope*.

CAUTION!

ALL MAGNETIC FIELDS BEING GENERATED BY MAGNETIC MATERIALS IN THE VICINITY OF THE SENSOR WILL CAUSE MALFUNCTIONING OF THE SENSOR.

THE MAGNET CAN BE DEMAGNETIZED IF IT IS EXPOSED TO TEMPERATURES HIGHER THAN 100°C / 212°F (E.G. HOT BRAKES). THE MAGNET WILL PERMANENTLY BECOME INOPERATIVE.

10 First use of the instrument

When all parts are installed securely and all wires are connected, re-connect the vehicle battery and switch on the ignition or power supply. If the electrical connections are correct, the "mologadget" logo will appear which will then switch to the speedometer. If this doesn't happen turn off the ignition and double-check all connections and wires.

11 Operation and use of the instrument

11.1 General instructions for operation with push button

All functions of the instrument can be activated with the push button. Pressing the button for different durations provides access to different levels of the display and the setup menu.

The system has three duration stages. For easy navigation in the setup menu, the duration stage will be displayed in the rev counter bar as follows:

Time Stage 1: < 1 sec	One third of the bar is illuminated. Function: selection of the next option or setting a digit.
Time Stage 2: 1–3 sec	Two thirds of the bar are illuminated. Function: selection of the next higher or lower level or selection of the next digit. Deleting saved information.
Time Stage 3: > 3 sec	The full bar is illuminated. Function: selection of the previous/primary level or leaving the menu item.

Please find the exact sequences for the setup menu in the flow chart (Chapter 16.2).

11.2 Analogue display of engine speed with LED bar

The rev. counter bar in the first line of the display can be adjusted using the setup menu in scales of 0–6,000, 0–8,000, 0–10,000, 0–14,000 and 0–16,000 rpm.

After entering the specific data of your vehicle and the correct rev. counter scale, the LED bar should display the correct engine speed. If the engine speed display is irregular and fluctuates select another input filter (InpF) in the setup menu.

11.3 Speed display (in km/h or mph)

The current vehicle speed is displayed in the menu point "Speed". The speed range is between 0 and 999 km/h or mph. The speed can also be displayed in mph. If the function "auto back" is activated (Setup/Disp/aback), the display will switch back to the speedometer after a while. If the

chosen duration is 00 s the function "auto back" is deactivated. In this setting the current display will re-appear after switching the instrument on and off.

11.4 Trip odometer (in km or mi)

The current day mileage will be displayed if you choose "Trip" on the menu. The distance covered will be displayed by a number from 0 and 999.99 km or mi. After 999.99 km or mi, the display starts again at 0 mi or km. To reset trip odometer keep the menu button pressed.

11.5 The Odometer (in km or mi)

The odometer displays the total mileage covered since installation of the instrument. The odometer can be reset to 0 in the set-up menu by selecting "RESET/ALL". To select different starting mileage other than 0 go to "RESET/ODO".

11.6 The engine speed display (in rpm)

This function displays the current engine speed as a numerical value from 0 and 20,000 rpm. This display requires vehicle specific settings in the setup menu.

11.7 Travel time display

A stopwatch measures the actual travel time (running only when vehicle is moving). Travel time will be recorded to the second up to 99 hours and 59 minutes. If travel time amounts to less than 59 min and 59 s it is displayed as minutes and seconds (mm.ss). Travel time of more than one hour will be displayed as hours and minutes (hh:mm). Travel time will be stored when instrument is switched off. Travel time can be reset by pressing the push button.

11.8 Threshold indication of the engine speed (shift light)

When a pre-set engine speed is reached (SETUP/DISPL/FLASH) all LEDs in the display will flash with a frequency of 5 Hz and with maximum brightness.

12 The Setup menu (adjusting the instrument)

All adjustments and calibrations of the *motoscope mini* are carried out with a single push button. For this reason the setup is divided in "levels." Selection and access of these levels as well as sub-levels is achieved by pressing the push button for different lengths of time which is displayed by an LED bar.

To enter the set-up menu press the push button in "Speed" mode until "Setup" appears in the display. The first menu option **Param** appears. Through short pressing of the push button three different levels can be accessed (**Param**, **Displ** and **Reset**).

12.1 The level PARAM (vehicle-specific adjustments)

The access to this menu option is shown in the diagram in the appendix (section 16.2). Here vehicle data can be entered which is necessary for measuring driving and engine speed. On this level the sub-levels **Teach**, **Circ**, **ImpW**, **ImpE**, and **Ver** can be accessed.

12.1.1 Teach

The function **Teach** offers an automatic calibration of the speedometer, for example if wheel scope or impulse per wheel rotation are not known. To use this function the vehicle must be driven at 50

km/h (31 mph). Start the **Teach** function with the menu button. The calibration takes 5 seconds. After the calibration the device switches back to the standard display.

12.1.2 Circ (Circumference)

The function **Circ** shows the circumference of the tyre in millimeters.

The appropriate tyre circumference can be chosen from the table in chapter 16.3.

If the tyre size is not listed in the table, measure the tyre circumference with the help of a string. Add speedometer advance of 5% by multiplying tyre circumference with 1.05. In order to count up the individual digits representing the measured tyre circumference enter the push button for duration 1. In order to go to the next digit, push the button for duration 2. In order to leave the menu push the button for duration 3.

If you use function **Teach** adjusting the menu won't be necessary.

12.1.3 ImpW (Impulse Wheel)

ImpWHL represents the number of impulses transmitted from the speedometer sensor per wheel turn. If only one magnet is used no changes are necessary in the setup (default value is 1). If the genuine speedometer sensor is used, the amount of output impulses per wheel turn have to be set. Pressing the button for duration 1 will change the current figure. Duration 2 will switch to the next figure. If you press the button for length of duration 3 you will leave the menu.

If you use function **Teach** adjusting the menu won't be necessary.

12.1.4 ImpE (Impulse Engine)

The function **ImpE** calibrates the rev. counter by counting the number of ignition impulses generated per crankshaft turn. This number depends on the number of cylinders, the engine type and/or the type of ignition. If the data is incorrect the engine speed displayed is usually either half or double the actual number. If your vehicle has more than one ignition coil only the impulses from one coil are relevant, namely the coil to which the yellow signal cable is attached. Impulse numbers range from 0.25 to 9. If "10" is reached the **ImpE** will start again at 0.25. In order to set the number press the push button for a short time (1 bar appears). To leave menu press button until 2 bars appear.

Examples:

1 cylinder, 4 stroke, 1 ignition coil:	ImpE= 0,5	(SR 500, XT 500)
4 cylinder, 4 stroke, 4 ignition coils:	ImpE= 0,5	
4 cylinder, 4 stroke, 2 ignition coils:	ImpE= 1	(GSXR 1000)
2 cylinder, 4 stroke, 1 ignition coil:	ImpE= 1	(Harley Davidson, dual fire)
2 cylinder, 4 stroke, 2 ignition coils:	ImpE= 0,5	(Harley Davidson, single fire)

How do I know my adjusting option?

99% of all motorcycles have ImpE= 0,5 or 1.

Set ImpE=1. Start the engine. If the idle revolution read out is half than normal choose ImpE=0,5.

12.1.5 ImpF (Impulse Filter)

The function **ImpF** offers a choice of four filters – A, B, C or D – for measuring the engine speed. If the engine speed display does not work with factory-set filter B please try one of the other filters.

12.1.6 Ver 1. X

This option shows the current software version. You can also activate or deactivate the Fast-Display-Modus. If activated, the speed of the display scrolling is increased by 100%. Exit this menu by pressing button for duration 1. Press button for duration 2 to activate/deactivate the Fast-Display-Modus. Exit the PARAM menu by pressing button for duration 2.

12.2 The level "Displ" (Display)

All display relevant parameters can be adjusted with this menu option. The level **Displ** includes the menu options **Unit, Scale, Day, Night, Flash, Aback and VertM**, which can be adjusted individually.

12.2.1 Unit

Display can be changed from kilometers to miles (or v.v.) with this function by pressing the push button for duration 1 (one bar appears). In order to exit this menu option press the push button for duration 2 (two bars appear).

12.2.2 Scale

With this function the setting of the LED engine speed indication is carried out. By pressing the push button for duration 1 (one bar) the engine speed can be set to 6,000, 8,000, 10,000, 12,000, 14,000 or 16,000 (rev./min). In order to exit this menu option press push button for duration 2 (two bars).

12.2.3 Day

The *motoscope mini* features an integrated light sensor that distinguishes between daytime (light) and nighttime (dark).

In menu option **Day** brightness of LED display can be adjusted for daytime. The function Day offers the functions **low, med, high** or **high+**. In order to choose one of these functions press push button for duration 1 (one bar). In order to exit the menu option press push button for duration 2 (two bars).

Note: If function "**high+**" is selected a device for heat dissipation must be installed. Such a device could be a holding bracket made of aluminum or steel, to which the two fastening bolts of the device must have a direct contact. If heat dissipation cannot be achieved, e.g. in case of an integrated gas tank fitting the instrument can reach temperatures of up to 75 °C. The instrument switches off when the temperature exceeds a factory-set maximum. In this case brightness should be reduced to "high".

12.2.4 Night

In this menu option brightness of the LED display can be set for nighttime (darkness). Functions **low, med, high** or **high+** can be set by pressing the push button for duration 1 (one bar). In order to exit this menu option press the push button for duration 2 (two bars).

12.2.5 Flash (Shift light)

A threshold value for engine speed can be set in menu option **Flash**. The setting is used for the adjustment of a simulated gear shift light. When exceeding the set number all display LEDs flash with maximum brightness and with a frequency of 5 Hz.

In order to select individual numbers representing the desired threshold press the push button for duration 1 (one bar). In order to go to the next digit press the button for duration 2 (2/3 of the LED bar). In order to exit this menu option press push button for duration 3 (3/3 of LED bar).

12.2.6 Aback (Auto back)

This function controls the time after the current screen jumps back to the driving speed indication automatically. The factory setting is 30s. If the digits are set to "00" function is deactivated. Only in this setting the current screen will appear again after restart of the instrument. In order to select individual digits representing the chosen time press push button for duration 1. For the next digit push button for duration 2. Exit menu by pressing push button for duration 3.

12.2.7 VertM (Vertical mode)

If the instrument shall be mounted in a vertical position or upside down, the function **VertM** makes it possible to rotate the display by 90°, 180° or 270°.

Within this menu option you can choose between options "std", "left", "right" and "up/dn".

The option "std" activates the standard horizontal display, "left" the vertical display with the rev. counter bar on the left side, "right" the vertical display with the rev. counter bar on the right side and "up/dn" rotate the display up side down. Press push button for duration 1 to change option. Choose option and leave menu option with push button duration 3.

12.3 The level "RESET"

In **RESET** all or individually selected digits can be set to 0 or to their default values. Furthermore, the total odometer reading can be set to an individual number (e.g. to the former odometer reading). In level **RESET** options "odo" and "all" can be chosen.

12.3.1 Odo (Odometer)

Option "ODO" allows adjustment of the total odometer reading. In order to scroll through the digits, press push button for duration 1 (one bar). To move to the next position press button for duration 2. To exit the menu option press button for duration 3.

12.3.2 All

In function "ALL" all adjustments and entered data will be deleted, including total odometer readings and default numbers will be restored!

Important! If this function is activated the following should be considered:

Press push button for duration 2: Deletes everything and leaves the menu.

Press push button for duration 3: Exits menu without deleting anything.

13 Cleaning of instrument

Use only gentle, non-corrosive detergents and a soft cloth for cleaning the *motoscope mini*. Avoid anything that might scratch the aluminium casing and the display surface. Should any scratching occur, we recommend special polishing pastes in order to remove them from the display. Such pastes can be found, for example, in equipment stores for mobile telephones. Furthermore, we suggest the use of silicon spray from time to time. This keeps the colour of the anodised casing fresh and protects the instrument from dirt.

14 Safety instructions

The *motoscope mini* provides a lot of information at one time. Users consequently require a certain "training" period in order to recognise all the given information quickly and correctly. Please take this into account, particularly during your first rides with the *motoscope mini* and do not distract yourself by watching the instrument in public traffic.

The user of the instrument is responsible for the correct entry of all relevant data as well as for the adjustment of the speedometer and all other functions. In particular, the fitting of the dry reed contact as well as the input of all calculation factors for speed determination must do with great care. The user is also responsible for mounting the instrument, the sensors, and all other accessory parts to the vehicle correctly and securely.

DO NOT OPERATE THE INSTRUMENT WHILE DRIVING! THIS MAY CAUSE LOOSING CONTROL OVER THE VEHICLE AND WILL RESULT TO A ACCIDENT WITH SERIOUS INJURIES OR DEATH.

15 Trouble shooting

15.1 After the installation

- Make sure the supply voltage is minimum 7 V. Check the vehicles battery.
- Do not use a battery charger to test the Instrument.
- Check all cables for correct installation and contact.
- Check all cables, for correct polarities and short-circuits.
- **Defective Instrument? So you can check instruments inputs and functions by yourself:**
 - perform a reset
 - disconnect all wires from vehicle wiring loom
 - connect only +12 V to the red cable and Earth to the black cable
 - now the display must be illuminated, if not check the power source and cables for polarity
 - inch the green cable to earth until you see the Speedometer screen (Speed)
 - inch the white cable to earth, if you can see now any numbers, this input is working correctly
 - inch the green cable to earth until you see the Engine Speed screen (RPM)
 - inch the yellow cable to earth, if you can see now any numbers, this input is working correctly
 - If this test was successful, the instrument is working correctly – check your connections to the vehicle. If the test was not successful you have to return the instrument for check & repair.

15.2 Return and complains

If you like to return a defective instrument for repair or change please observes following issues:

- Make sure again there is no connection failure. In doubt use a different voltage source to recheck.
- fill the repair return form (<http://motogadget.com/en/repairinquiry>) and attach it
- Not prepaid shipments will be rejected.
- The shipment to motogadget is carried out by your own risk - you are responsible for a sufficient insurance.
- Make sure the package is adequate.
- If you are located outside the EU, you have to declare "repair item" and value 1 Euro in shipment custom declaration.
- Service provided for all not instrument related malfunctions (i.e. defective connection joints, wrong parameter settings and other vehicle related problems) will be charged with 20 EUR.
- Software updates for extending functionality will be charged with 25 EUR.

The *motogadget* team wishes you pleasant and safe riding, and lots of fun with your new *motoscope mini*.

16 Appendix

16.1 Connection Scheme

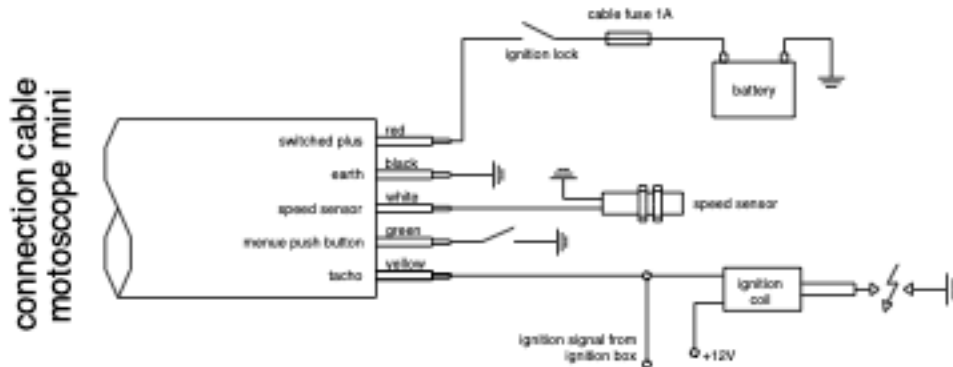

16.2 General overview of operation

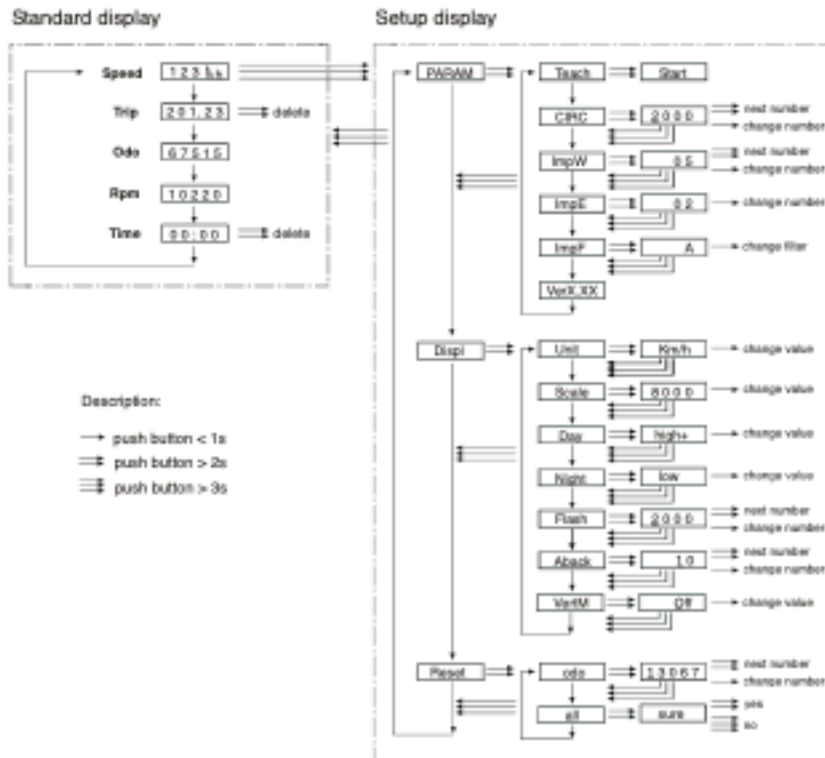

16.3 Table of tire circumferences

front wheel tire sizes and circumference settings			
16" tire inner diameter			
tire size	circumference (mm)	tire size	circumference (mm)
100/90-16	1770	130/70-16	1778
110/90-16	1824	135/90-16	1933
120/90-16	1806	150/90-16	1951
120/90-16	1878		
17" tire inner diameter			
tire size	circumference (mm)	tire size	circumference (mm)
100/90-17	1788	120/70-17	1812
120/70-17	1770	120/90-17	1884
120/90-17	1858	135/90-17	1778
120/90-17	1740	135/70-17	1854
18" tire inner diameter			
tire size	Abrollumfang (mm)	tire size	circumference (mm)
1.00-18	1894	110/90-18	1912
1.25-18	1950	115/90-18	1978
1.50-18	1960	120/70-18	1888
90/90-18	1860	120/90-18	1960
100/90-18	1863	120/90-18	2032
100/90-18	1924	130/70-18	1930
19" tire inner diameter			
tire size	circumference (mm)	tire size	circumference (mm)
1.00-19	1972	100/90-19	2002
1.25-19	2008	110/90-19	2057
1.50-19	2058		
21" tire inner diameter			
tire size	Abrollumfang (mm)	tire size	circumference (mm)
80/90-21	2045	90/90-21	2099
rear wheel tire sizes and circumference settings			
15" tire inner diameter			
tire size	circumference (mm)	Reifengröße	circumference (mm)
90/90-15	1770	140/90-15	1827
110/90-15	1814	140/90-15	1912
120/80-15	1806	170/90-15	1972
120/90-15	1878	180/70-15	1912
120/70-15	1776	200/70-15	1996
130/90-15	1933		
16" tire inner diameter			
tire size	circumference (mm)	tire size	circumference (mm)
100/90-16	1770	150/90-16	1951
110/90-16	1824	160/90-16	1999
120/80-16	1806	180/90-16	1878
120/90-16	1957	180/70-16	1987
130/70-16	1776	200/90-16	1924
130/90-16	1933	240/50-16	1951
140/90-16	1980		
17" tire inner diameter			
tire size	circumference (mm)	tire size	circumference (mm)
120/90-17	1957	180/90-17	1884
120/70-17	1854	160/70-17	1981
130/80-17	1933	170/90-17	1931
130/90-17	2011	180/55-17	1959
140/80-17	1981	190/90-17	1878
150/80-17	1948	200/90-17	1919
150/70-17	1930	210/50-17	1919
150/80-17	2029		
18" tire inner diameter			
tire size	circumference (mm)	tire size	circumference (mm)
110/80-18	1912	150/70-18	2034
110/90-18	1978	160/90-18	1960
110/100-18	2099	170/90-18	1996
120/90-18	2052	180/55-18	1981
130/80-18	2008	200/90-18	1951
140/80-18	2057	240/90-18	1960