

Instruction manual MSM-Combi

EXCLUSION OF LIABILITY

INSTRUMENT HOUSINGS AND ALL OTHER DELIVERED PARTS MUST NOT BE OPENED OR DISMANTLED. IN CASE OF NON-COMPLIANCE ALL GUARANTEE CLAIMS BECOME INVALID. MOTOGADGET ACCEPTS NO LIABILITY FOR DIRECT OR INDIRECT DAMAGE OR SUBSEQUENT DAMAGE OF ANY KIND RESULTING FROM THE USE, INSTALLATION OR CONNECTION OF INSTRUMENTS, THE SENSORS OR OTHER DELIVERED EQUIPMENT. THIS EXCLUSION OF LIABILITY PARTICULARLY INCLUDES DAMAGE TO PERSONS, MATERIAL LOSSES AND FINANCIAL DAMAGES. THE USE OF THE HANDLEBAR TOP CLAMP IN AREAS OF PUBLIC TRAFFIC IS UNDERTAKEN AT THE USER'S OWN RISK.

Installation

MSM-Combi features 5 indicator lights. It allows to installing the motoscope mini in following ways:

Handlebar mount with cables inside for 22mm and 1" diameter

- hold the rear plate at the desired handle bar position and mark two holes for cables and two holed for the mounting screws
- drill two holes with 2,4mm diameter and tap a M3 thread
- drill both cable holes with 6mm drill and remove burr, tape the edges with textile tape
- thread the MSM-Combi cable trough the handle bar and mount the housing with two M3 screws
- thread the motoscope mini cable trough the handle bar, insert the instrument and clamp it with a M3 stud screw.

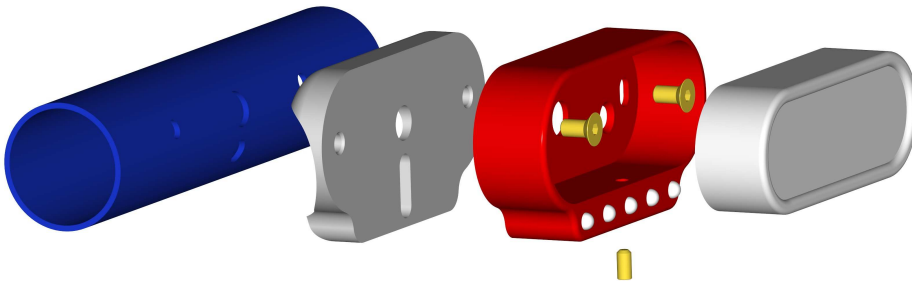

Handlebar mount with cables outside for 22mm and 1" diameter

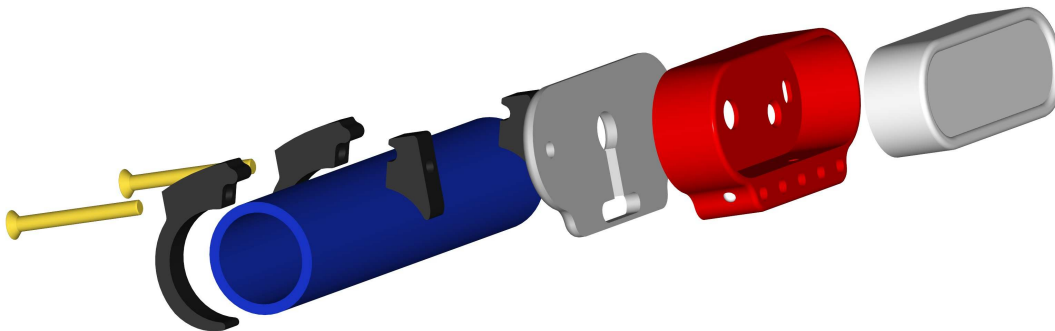

Mount on the universal bracket (bracket can be drilled, bend or cut)

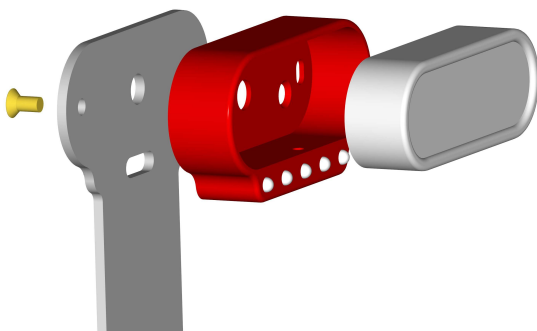

Installation with a weld-in-housing for a fuel tank integration

- weld a stainless steel tube (inner dia. 10mm, leght = fuel tank height) at the cable outlet on the backside of the weld-in-housing.
- make a cut out in the shape of the weld-in-housing at the topside of the fuel tank.
- drill a hole with diameter of the steel tube in the opposite fuel tank bottom
- weld the weld-in-housing together with the cut out at the fuel tank
- weld the tube with the hole at the bottom side
- check the leak tightness / paint
- mount the MSM-Combi housing into the weld-in-housing by two M3 screws
- thread the motoscope cable trough the tube and install the instrument with a small amount of silicone rubber into the weld-in-housing

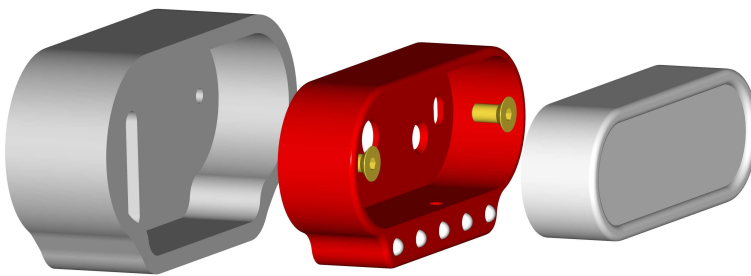

Electrical connection

Remove the vehicle battery before continuing the electrical wiring or interrupt the connection to the onboard power supply. Then connect the warning lights as follows:

cable color	function	polarity
red	turn left	+12V
blue	turn right	+12V
orange	turn earth	Masse
green	high beam	+12V
yellow	high beam	Masse
white	neutral	+12V
black	neutral	Masse
brown	oil pressure	+12V
violett	oil pressure	Masse

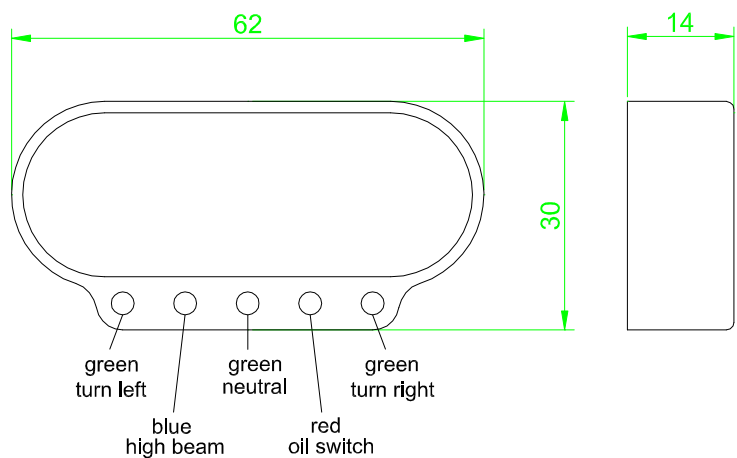

As a option the right turn control lamp can be used for a additional warning function which will provide a +12V signal. To connect both sides of turn signals together to the left turn control lamp the please refer as the schematic below.

