



KION NORTH AMERICA

---

# Counterbalanced Forklift 3,500 lbs. Capacity

---

KBET18  
48V Electric Forklift Truck

---



# Technical Data

May 2019

POS	ITEM DESCRIPTION				
Specification	1.1	Manufacturer	KION BAOLI		
	1.2	Model designation	KBET18		
	1.2.1	Chassis configuration	3-Wheel		
	1.3	Power unit: battery, diesel, LP, gas	Electric		
	1.4	Operation: manual, pedestrian, rider standing, rider seated, order picker	Rider Seated		
	1.5	Rated capacity/rated load	Q	3500 lbs	1600 kg
	1.6	Load center distance	c	24 in	600 mm
	1.8	Load distance, center of drive axle to fork	x	14.7 in	375 mm
	1.9	Wheel base	y	51 in	1295 mm
Weight	2.1	Service weight (with battery)	8150 lbs		
	2.1a	Service weight (without battery)	6350 lbs		
	2.2	Axle loading, with load front/rear	11375/705 lbs		
	2.3	Axle loading, without load front/rear	4190/3970 lbs		
Wheels and Tires	3.1	Tire type: cushion, cushion super elastic, pneumatic	S/E		
	3.2	Tire size, front	18x7-8		
	3.3	Tire size, rear	16x6-8		
	3.5	Wheels, number front/rear (x = driven wheels)	2x/2		
	3.6	Tread, front	b <sub>10</sub>	35.0 in	890 mm
	3.7	Tread, rear	b <sub>11</sub>	8.0 in	205 mm
	4.1	Mast/fork carriage tilt forward/backward	5/5		
Dimensions and Overall Sizes	4.2	Height of mast lowered	h <sub>1</sub>	86.0 in	2185 mm
	4.3	Free lift	h <sub>2</sub>	46.6 in	1185 mm
	4.4	Lift	h <sub>3</sub>	185.0 in	4700 mm
	4.5	Height of mast extended	h <sub>4</sub>	218.0 in	5542 mm
	4.7	Height of overhead guard (cabin)	h <sub>6</sub>	79.0 in	2015 mm
	4.8	Seat height relating to SIP/stand height	h <sub>7</sub>	38.0 in	958 mm
	4.12	Height of tow coupling	h <sub>10</sub>	24.0 in	600 mm
	4.19	Overall length	l <sub>1</sub>	116.7 in	2965 mm
	4.20	Length to fork face	l <sub>2</sub>	74.6 in	1895 mm
	4.21	Overall width	b <sub>1</sub> /b <sub>2</sub>	42.0 in	1066 mm
	4.22	Fork dimensions DIN ISO 2331	s/e/l	1.4/4.7/42 in	35/120/1070 mm
	4.23	Fork carriage: class	Class II		
	4.24	Fork carriage: width	b <sub>3</sub>	38.1 in	968 mm
	4.31	Ground clearance under mast, with load	m <sub>1</sub>	4.7 in	120 mm
	4.32	Ground clearance, center of wheelbase	m <sub>2</sub>	4.3 in	110 mm
	4.33	Aisle width with pallet 40" x 48" across forks	Ast	127.6 in	3240 mm
4.35	Turning radius	Wa	61 in	1550 mm	
Performance	5.1	Travel speed, with/without load	8.7/9.6 mph		
	5.2	Lift speed, with/without load	55.0/88.6 fpm		
	5.3	Lowering speed, with/without load	90.5/82.7 fpm		
	5.5	Drawbar pull, with/without load	1956 lbf		
	5.7	Gradeability, with/without load	20%/20%		
	5.10	Service brake	Electric / Mechanical		
Electric engine	6.1	Drive motor rating (60 min. rating)	2x6.5 kW		
	6.2	Lift motor (15% rating)	15 kW		
	6.3	Battery compartment dimension (l x w x h)	38.4/21.75/23.2 in		
	6.4	Battery voltage	U	48 V	
	6.4.1	Nominal capacity K5	K5	505/525/595 Ah	
	6.5	Battery weight	1786~2028 lbs		810~920 kg
Other	10.1	Operating pressure for attachments	160 bar		
	10.7	Sound pressure level at the driver's seat	<75 dB(A)		
		Drive control	AC		

\* Maximum battery height should not exceed 23.2 in. (590 mm)

## Performance

The AC drive and lift motors provide excellent power to maximize productivity. Energy-efficient design allows for continuous operation for day-to-day jobs.

## Quality & Support

Baoli forklifts come with the KION NA Standard Warranty.

1<sup>st</sup> Year: Standard Equipment/Unlimited Hours

2<sup>nd</sup> Year: Standard Powertrain/4,000 Hours

Extended warranty available

## Service Network

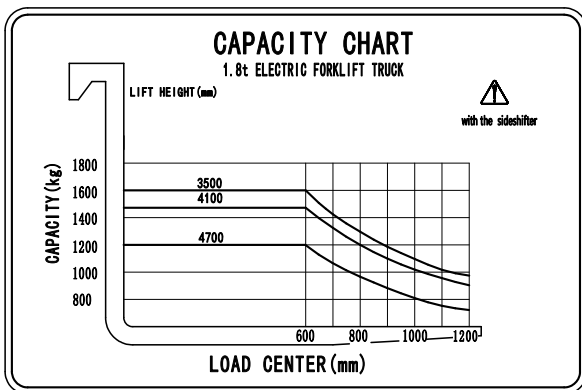
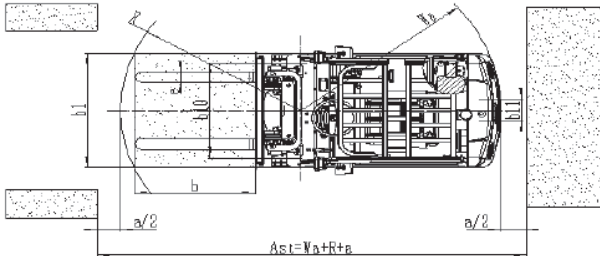
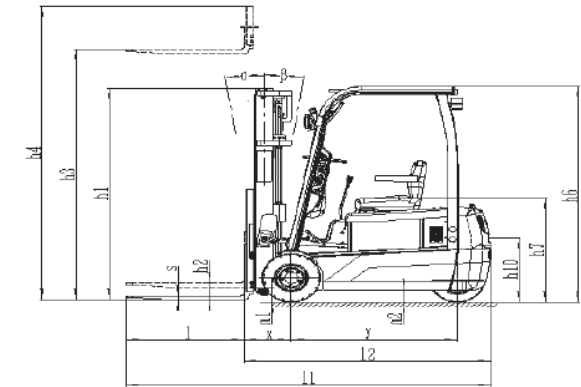

Fully integrated into the KION North America supply chain and service system, Baoli provides shared resources from KION brands which offers a well-developed sales and service network. With Baoli spare parts in stock at the KION North America warehouse, spare parts delivery is possible within 24 hours throughout the U.S. by our authorized dealers.

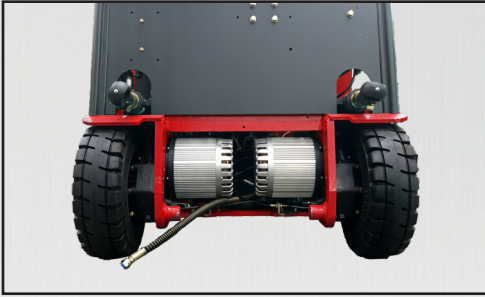

## Standard Equipment

- Solid, pneumatic (SE) drive and steer tires
- Triplex FFL 86" - 185" - 46.7" mast
- 8° forward, 5° backwards tilt
- 38" wide Class II carriage
- 43" wide x 40" high load backrest
- 79" high overhead guard
- Hang-on sideshifter
- Overhead guard entry grip
- Left and right external rear view mirrors
- Rear pillar assist with horn
- Three individual hydraulic control levers
- Three-function valve and reeving
- Tilting adjustable steering column
- Comfort suspension seat with orange seat belt
- Brake, reverse, turn signal lights
- LED twin spotlights forward - OHG-mounted
- Reflective silver stripe
- Back up alarm and strobe light
- KION NA Standard Warranty



-  — Baoli Red
-  — Baoli Blue
-  — Baoli Orange

## 48V AC Power

- Dual AC drive motors
- AC lift motor
- SME controller

## Compact Design

- Compact design for tight spaces
- Low center of gravity
- Standard KION structure painting

## Options

- 4th-function hydraulics
- 4th-function clamp interlock
- Smooth cushion tires
- Integrated sideshifter
- Blue spotlight rear - OHG-mounted
- LED spotlight rear - OHG-mounted
- Baoli blue or orange paint

KION North America Corporation  
 2450 West 5th North Street, Summerville, SC 29483  
 Phone: 843 875 8000 Truck Sales Fax: 843 875 8471  
 E-mail: trucksales.na@kiongroup.com  
 www.kion-na.com

Standard truck meets all applicable mandatory requirements of ANSI/ITSDF B56.1 standards for powered industrial trucks. NOTE: Performance data may vary due to motor and system efficiency tolerances. The performance depicted represents nominal values obtained under typical operating conditions. Metric dimensions are in millimeters unless otherwise specified. All metric dimensions are not direct equivalents due to rounding data. The descriptions and specifications included on this data sheet were in effect at the time of printing. KION North America Corporation reserves the right to make improvements and changes in specification or design without notice and without incurring obligation. Please check with your authorized Baoli dealer for information on possible updates or revisions.