

## 6" x 48" Belt & 10" Disc Sander with Stand



# Operator's Manual

Record the serial number and date of purchase in your manual for future reference.

The serial number can be found on the specification label on the rear of your machine.

Serial Number: \_\_\_\_\_ Date of purchase: \_\_\_\_\_

For technical support, email [techsupport@rikontools.com](mailto:techsupport@rikontools.com) - For parts questions, email [parts@rikontools.com](mailto:parts@rikontools.com)

## TABLE OF CONTENTS

Specifications.....	2
Safety Instructions .....	3 - 6
Getting To Know Your Machine .....	7
Contents of Package .....	7 - 8
Assembly .....	8 - 11
Adjustments.....	11 - 15
Operation .....	16 - 18
Maintenance .....	19
Electricals & Wiring Diagram .....	5 & 19
Troubleshooting .....	20 - 21
Accessories .....	21
Sander Parts Diagram .....	22
Sander Parts List .....	23
Stand Parts Diagram & Parts List .....	24
Stand Assembly .....	25
Notes .....	26
Warranty .....	27

## SPECIFICATIONS

Motor .....	1 HP, 1 Ph
Motor Speed (no load).....	3,450 RPM
Volts .....	120 V
Amps, Hertz .....	8 A, 60 Hz
Belt Size .....	6" x 48"
Belt Speed (no load) .....	1,836 FPM
Disc Size (PSA) Diameter .....	10"
Disc Speed (no load) .....	2,510 RPM
Sanding Belt Frame Tilt .....	0-90°
Belt Fence Size .....	8-3/16" x 2-1/8" or 7-1/4" x 1-3/8"
Belt Fence Tilt .....	90°
Disc Table Size (Length x Width) .....	13" x 6-11/16"
Disc Table Tilt .....	0-45°
Miter Gauge 'T' Slot (Width x Depth) .....	5/8" x 1/4"
Dust Port (1) .....	2" (50 mm) OD, 1-3/4" (45 mm) ID
Power Cord .....	6 Feet, 16 AWG
Overall Size (LxWxH).....	31-3/16" x 21" x 15-7/16" (792 x 532 x 392 mm)
Base Size (approx.) .....	18-3/8" x 12-1/4" (467 x 311 mm)
Net Weight .....	85 lbs (38.5 kg)

**NOTE:** The specifications, photographs, drawings and information in this manual represent the current model when the manual was prepared. Changes and improvements may be made at any time, with no obligation on the part of Rikon Power Tools, Inc. to modify previously delivered units. Reasonable care has been taken to ensure that the information in this manual is correct, to provide you with the guidelines for the proper safety, assembly and operation of this machine.

# SAFETY INSTRUCTIONS

**IMPORTANT!** Safety is the single most important consideration in the operation of this equipment. **The following instructions must be followed at all times.** Failure to follow all instructions listed below may result in electric shock, fire, and/or serious personal injury.

There are certain applications for which this tool was designed. We strongly recommend that this tool not be modified and/or used for any other application other than that for which it was designed. If you have any questions about its application, do not use the tool until you have contacted us and we have advised you.

## SAFETY SYMBOLS



**SAFETY ALERT SYMBOL:** Indicates DANGER, WARNING, or CAUTION. This symbol may be used in conjunction with other symbols or pictographs.



Indicates an imminently hazardous situation, which, if not avoided, could result in death or serious injury.



Indicates a potentially hazardous situation, which, if not avoided, could result in death or serious injury.



Indicates a potentially hazardous situation, which, if not avoided, could result in minor or moderate injury.

**NOTICE:** Shown without Safety Alert Symbol indicates a situation that may result in property damage.

## GENERAL SAFETY

**KNOW YOUR POWER TOOL.** Read the owner's manual carefully. Learn the tool's applications, work capabilities, and its specific potential hazards.

### BEFORE USING YOUR MACHINE

To avoid serious injury and damage to the tool, read and follow all of the Safety and Operating Instructions before operating the machine.

1. **WARNING** Some dust created by using power tools contains chemicals known to the State of California to cause cancer, birth defects, or other reproductive harm. Some examples of these chemicals are:

- Lead from lead-based paints.
- Crystalline silica from bricks, cement, and other masonry products.
- Arsenic and chromium from chemically treated lumber.

Your risk from these exposures varies, depending on how often you do this type of work. To reduce exposure to these chemicals: work in a well ventilated area and work with approved safety equipment, such as dust masks that are specially designed to filter out microscopic particles.

For more information go to [www.P65Warnings.ca.gov](http://www.P65Warnings.ca.gov)

2. **READ** the entire Owner's Manual. **LEARN** how to use the tool for its intended applications.

3. **GROUND ALL TOOLS.** If the tool is supplied with a 3 prong plug, it must be plugged into a 3-contact electrical receptacle. The 3rd prong is used to ground the tool and provide protection against accidental electric shock. **DO NOT** remove the 3rd prong. See Grounding Instructions on the following pages.

4. **AVOID A DANGEROUS WORKING ENVIRONMENT.** **DO NOT** use electrical tools in a damp environment or expose them to rain.

5. **DO NOT** use electrical tools in the presence of flammable liquids or gasses.

6. **ALWAYS** keep the work area clean, well lit, and organized. **DO NOT** work in an environment with floor surfaces that are slippery from debris, grease, and wax.

7. **KEEP VISITORS AND CHILDREN AWAY. DO NOT** permit people to be in the immediate work area, especially when the electrical tool is operating.

8. **DO NOT FORCE THE TOOL** to perform an operation for which it was not designed. It will do a safer and higher quality job by only performing operations for which the tool was intended.

9. **WEAR PROPER CLOTHING. DO NOT** wear loose clothing, gloves, neckties, or jewelry. These items can get caught in the machine during operations and pull the operator into the moving parts. The user must wear a protective cover on their hair, if the hair is long, to prevent it from contacting any moving parts.

10. **CHILDPROOF THE WORKSHOP AREA** by removing switch keys, unplugging tools from the electrical receptacles, and using padlocks.

11. **ALWAYS UNPLUG THE TOOL FROM THE ELECTRICAL RECEPTACLE** when making adjustments, changing parts or performing any maintenance.

# SAFETY INSTRUCTIONS

**12. KEEP PROTECTIVE GUARDS IN PLACE AND IN WORKING ORDER.**

**13. AVOID ACCIDENTAL STARTING.** Make sure that the power switch is in the “OFF” position before plugging in the power cord to the electrical receptacle.

**14. REMOVE ALL MAINTENANCE TOOLS** from the immediate area prior to turning “ON” the machine.

**15. USE ONLY RECOMMENDED ACCESSORIES.** Use of incorrect or improper accessories could cause serious injury to the operator and cause damage to the tool. If in doubt, check the instruction manual that comes with that particular accessory.

**16. NEVER LEAVE A RUNNING TOOL UNATTENDED.** Turn the power switch to the “OFF” position. **DO NOT** leave the tool until it has come to a complete stop.

**17. DO NOT STAND ON A TOOL.** Serious injury could result if the tool tips over, or you accidentally contact the tool.

**18. DO NOT** store anything above or near the tool where anyone might try to stand on the tool to reach it.

**19. MAINTAIN YOUR BALANCE. DO NOT** extend yourself over the tool. Wear oil resistant rubber soled shoes. Keep floor clear of debris, grease, and wax.

**20. MAINTAIN TOOLS WITH CARE.** Always keep tools clean and in good working order. Keep all blades and tool bits sharp, dress grinding wheels and change other abrasive accessories when worn.

**21. EACH AND EVERY TIME, CHECK FOR DAMAGED PARTS PRIOR TO USING THE TOOL.** Carefully check all guards to see that they operate properly, are not damaged, and perform their intended functions. Check for alignment, binding or breaking of moving parts. A guard or other part that is damaged should be immediately repaired or replaced.

**22. DO NOT OPERATE TOOL WHILE TIRED, OR UNDER THE INFLUENCE OF DRUGS, MEDICATION OR ALCOHOL.**

**23. SECURE ALL WORK.** Use clamps or jigs to secure the work piece. This is safer than attempting to hold the work piece with your hands.

**24. STAY ALERT, WATCH WHAT YOU ARE DOING, AND USE COMMON SENSE WHEN OPERATING A POWER TOOL.**

A moment of inattention while operating power tools may result in serious personal injury.

**25. ALWAYS WEAR A DUST MASK TO PREVENT INHALING DANGEROUS DUST OR AIRBORNE PARTICLES,** including wood dust, crystalline silica dust and asbestos dust. Direct particles away from face and body. Always operate tool in well ventilated area and provide for proper dust removal. Use dust collection system wherever possible. Exposure to the dust may cause serious and permanent respiratory or other injury, including silicosis (a serious lung disease), cancer, and death. Avoid breathing the dust, and avoid prolonged contact with dust. Allowing dust to get into your mouth or eyes, or lay on your skin may promote absorption of harmful material. Always use properly fitting NIOSH/OSHA approved respiratory protection appropriate for the dust exposure, and wash exposed areas with soap and water.

**26. USE A PROPER EXTENSION CORD IN GOOD CONDITION.** When using an extension cord, be sure to use one heavy enough to carry the current your product will draw. The table on the following page shows the correct size to use depending on cord length and nameplate amperage rating. If in doubt, use the next heavier gauge. The smaller the gauge number, the larger diameter of the extension cord. If in doubt of the proper size of an extension cord, use a shorter and thicker cord. An undersized cord will cause a drop in line voltage resulting in a loss of power and overheating.  
**USE ONLY A 3-WIRE EXTENSION CORD THAT HAS A 3-PRONG GROUNDING PLUG AND A 3-POLE RECEPTACLE THAT ACCEPTS THE TOOL’S PLUG.**

**27. ADDITIONAL INFORMATION** regarding the safe and proper operation of this product is available from:

- Power Tool Institute  
1300 Summer Avenue  
Cleveland, OH 44115-2851  
[www.powertoolinstitute.org](http://www.powertoolinstitute.org)
- National Safety Council  
1121 Spring Lake Drive  
Itasca, IL 60143-3201  
[www.nsc.org](http://www.nsc.org)
- American National Standards Institute  
25 West 43rd Street, 4th Floor  
New York, NY 10036  
[www.ansi.org](http://www.ansi.org)
- ANSI 01.1 Safety Requirements for Woodworking Machines and the U.S. Department of Labor regulations  
[www.osha.gov](http://www.osha.gov)

**28. SAVE THESE INSTRUCTIONS.** Refer to them frequently and use them to instruct others.

# SAFETY INSTRUCTIONS

## ELECTRICAL SAFETY

**⚠ WARNING:** THIS TOOL MUST BE GROUNDED WHILE IN USE TO PROTECT THE OPERATOR FROM ELECTRIC SHOCK.

**IN THE EVENT OF A MALFUNCTION OR BREAKDOWN,** grounding provides the path of least resistance for electric current and reduces the risk of electric shock. This tool is equipped with an electric cord that has an equipment grounding conductor and requires a grounding plug (not included). The plug **MUST** be plugged into a matching electrical receptacle that is properly installed and grounded in accordance with **ALL** local codes and ordinances.

**DO NOT MODIFY ANY PLUG.** If it will not fit the electrical receptacle, have the proper electrical receptacle installed by a qualified electrician.

**IMPROPER ELECTRICAL CONNECTION** of the equipment grounding conductor can result in risk of electric shock. The conductor with the green insulation (with or without yellow stripes) is the equipment grounding conductor. **DO NOT** connect the equipment grounding conductor to a live terminal if repair or replacement of the electric cord or plug is necessary.

**CHECK** with a qualified electrician or service personnel if you do not completely understand the grounding instructions, or if you are not sure the tool is properly grounded when installing or replacing a plug.

**USE ONLY A 3-WIRE EXTENSION CORD THAT HAS THE PROPER TYPE OF A 3-PRONG GROUNDING PLUG THAT MATCHES THE MACHINE'S 3-PRONG PLUG AND ALSO THE 3-POLE RECEPTACLE THAT ACCEPTS THE TOOL'S PLUG. \***

**REPLACE A DAMAGED OR WORN CORD IMMEDIATELY.**

This tool is intended for use on a circuit that has an electrical receptacle as shown in **FIGURE A**. It shows a 3-wire electrical plug and electrical receptacle that has a grounding conductor. If a properly grounded electrical receptacle is not available, an adapter as shown in **FIGURE B** can be used to temporarily connect this plug to a 2-contact ungrounded receptacle. The adapter has a rigid lug extending from it that **MUST** be connected to a permanent earth ground, such as a properly grounded receptacle box. **THIS ADAPTER IS PROHIBITED IN CANADA.**

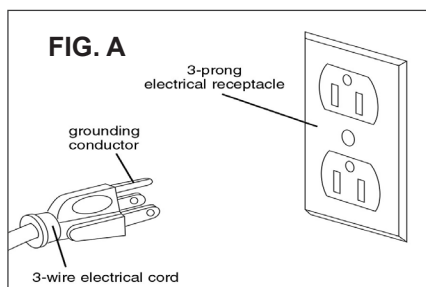

## EXTENSION CORDS

**⚠ WARNING:** THE USE OF AN EXTENSION CORD WITH THIS MACHINE IS NOT RECOMMENDED. For best power and safety, plug the machine directly into a dedicated, grounded electrical outlet that is within the supplied cord length of the machine.

If an extension cord needs to be used, it should only be for a limited operation of the machine. The extension cord should be as short as possible in length, and have a minimum gauge size of 14AWG.

**⚠ WARNING:** Check extension cords before each use. If damaged replace immediately. Never use a tool with a damaged cord, since touching the damaged area could cause electrical shock, resulting in serious injury.

Use a proper extension cord. Only use cords listed by Underwriters Laboratories (UL). Other extension cords can cause a drop in line voltage, resulting in a loss of power and overheating of tool. When operating a power tool outdoors, use an outdoor extension cord marked "W-A" or "W". These cords are rated for outdoor use and reduce the risk of electric shock.

### MINIMUM RECOMMENDED GAUGE FOR EXTENSION CORDS (AWG)

120 VOLT OPERATION ONLY				
	25' LONG	50' LONG	100' LONG	150' LONG
0 to 6 Amps	18 AWG	16 AWG	16 AWG	14 AWG
6 to 10 Amps	18 AWG	16 AWG	14 AWG	12 AWG
10 to 12 Amps	16 AWG	16 AWG	14 AWG	12 AWG

**⚠ WARNING:** Keep the extension cord clear of the working area. Position the cord so that it will not get caught on lumber, tools or other obstructions while you are working with your power tool.

\* Canadian electrical codes require extension cords to be certified SJT type or better.

\*\* The use of an adapter in Canada is not acceptable.

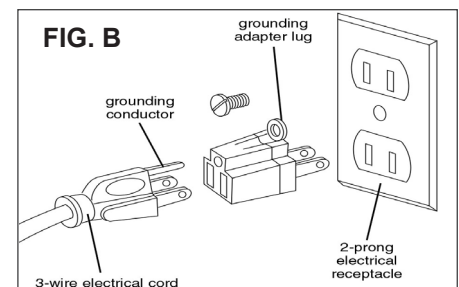



# SAFETY INSTRUCTIONS

## SPECIFIC SAFETY INSTRUCTIONS FOR SANDERS

This machine is intended for the surfacing of natural, solid woods. Any other use not as specified, including modification of the machine or use of parts not tested and approved by the equipment manufacturer can cause unforeseen damage, and invalidate the warranty.

**ATTENTION:** Use of this sander still presents risks that cannot be eliminated by the manufacturer. Therefore, the user must be aware that wood working machines are dangerous if not used with care and all safety precautions are adhered to.

### Special Safety Rules For Sanders

1. Do not operate this machine until you have read all of the following instructions.
2. Do not attempt to operate this machine until it is completely assembled.
3. Do not turn ON this machine if any pieces are damaged or missing.
4. This machine must be properly grounded.
5. If you are not familiar with the operation of the machine, obtain assistance from a qualified person.
6. It is highly recommended that this machine be firmly mounted to a flat and secure work surface or stand.
7. Always wear protective eyewear and hearing protection when operating this machine.
8. Always wear a dust mask and use adequate dust collection and proper ventilation. Use of sanders can produce harmful particles while sanding certain types of woods.
9. Do not wear loose clothing, gloves or jewelry when operating this machine. Keep long hair tied back.
10. Always make sure the power switch is in the OFF position prior to plugging in the machine.
11. Always make sure the power switch is in the OFF position and the machine is unplugged when doing any cleaning, assembly, setup operation, or when not in use.
12. Make sure all safety guards and hardware are securely tightened before operating the machine.
13. The use of any accessories or attachments not recommended may cause injury to you and damage your machine.
14. Abrasive discs and belts should be the recommended width and length of the manufacturer.
15. Replace worn, frayed or torn abrasives, as injury to the user, or the machine, may result.
16. Always keep your face and hands clear of moving parts such as belts, discs and pulleys.
17. Keep power supply cords free of moving parts of the sander. Damaged cords can result in electric shock.
18. Maintain a minimal gap clearance (1/16" or less) between the sanding disc or the sanding belt and their tables.
19. Always support the workpiece with the table or backstop during sanding.
20. Carefully feed work into the rotating sanding belt, or disc, on the downward direction, so that the abrasive action pushes the work down onto the tables where it can be controlled.
21. Do not force the work into the abrasives, as burning of the wood or stalling of the machine may result.
22. Remove material or debris from the work area. Keep work area neat and clean.

**This owner's manual is not a teaching aid and is intended to show assembly, adjustments, and general use.**

#### CALIFORNIA PROPOSITION 65 WARNINGS



**WARNING:** Drilling, sawing, sanding or machining wood products can expose you to wood dust, a substance known to the State of California to cause cancer. Avoid inhaling wood dust or use a dust mask or other safeguards for personal protection. For more information go to [www.P65Warnings.ca.gov/wood](http://www.P65Warnings.ca.gov/wood).



**WARNING:** This product can expose you to chemicals including Dibutyl phthalate, which is known to the State of California to cause birth defects or other reproductive harm. For more information go to [www.P65Warnings.ca.gov](http://www.P65Warnings.ca.gov)

## GETTING TO KNOW YOUR MACHINE

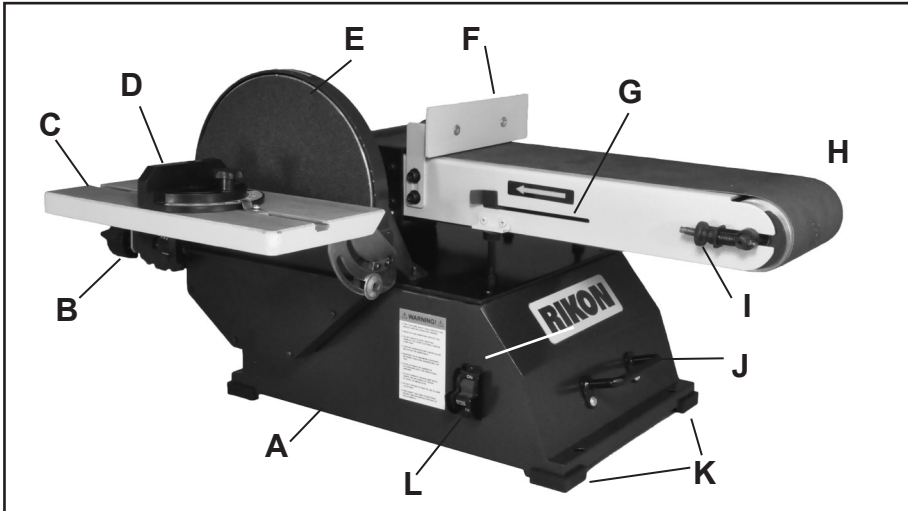

- A. Motor & Base Assembly
- B. Sanding Disc Table Controls
- C. Sanding Disc Table
- D. Miter Gauge
- E. Sandpaper Disc, 8", PSA
- F. Sanding Belt Fence
- G. Sanding Belt Tension Release
- H. Sanding Belt, 6" x 48"
- I. Sanding Belt Tracking Knob
- J. Carry Handle
- K. Rubber Foot
- L. ON/OFF Safety Switch

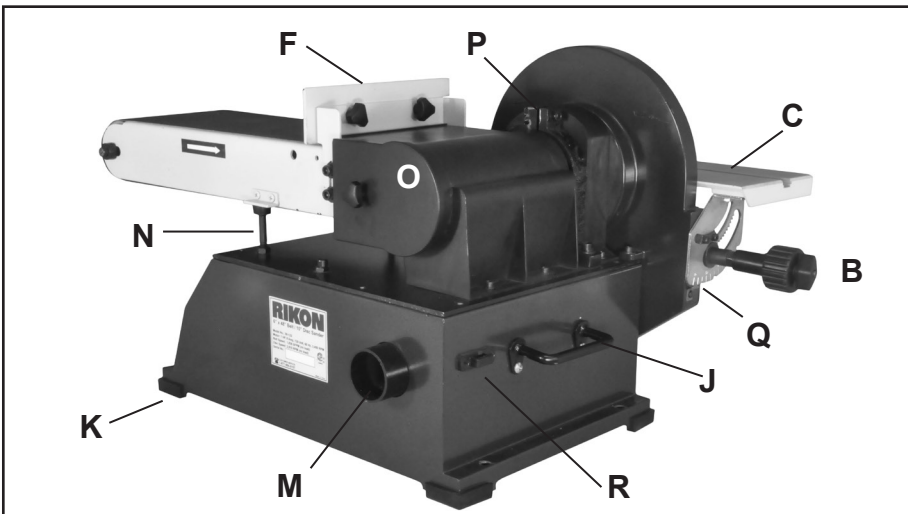

- M. Dust Port 2" O.D.
- N. Sanding Belt Frame Support
- O. Sanding Belt Cover
- P. Sanding Belt Frame Lock Screw
- Q. Sanding Disc Table Angle Support & Arrow Indicator
- R. Hex Wrench Tool Holder

## CONTENTS OF PACKAGE

Model 50-122 Sander is shipped complete in one box.

### UNPACKING AND CLEAN-UP

1. Carefully remove all contents from the shipping carton. Compare the contents with the list of contents to make sure that all of the items are accounted for, before discarding any packing material. Place parts on a protected surface for easy identification and assembly. If any parts are missing or broken, please call RIKON Customer Service (877-884-5167) as soon as possible for replacements. DO NOT turn your machine ON if any of these items are missing. You may cause injury to yourself or damage to the machine.
2. Report any shipping damage to your local distributor. Take photographs for any possible insurance claims.
3. Clean all rust protected surfaces with ordinary house hold type grease or spot remover. Do not use; gasoline, paint thinner, mineral spirits, etc. These may damage painted surfaces.
4. Apply a coat of paste wax to the table to prevent rust. Wipe all parts thoroughly with a clean dry cloth.
5. Set packing material and shipping carton aside. Do not discard until the machine has been set up and is running properly.

# CONTENTS OF PACKAGE

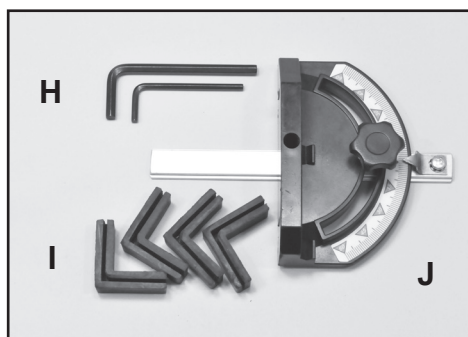
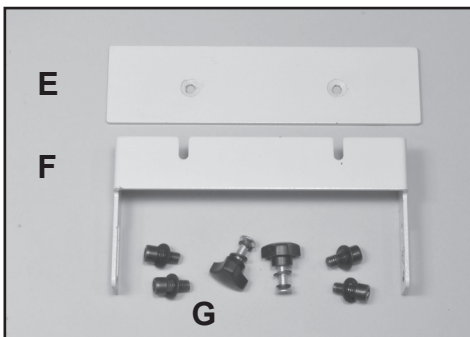
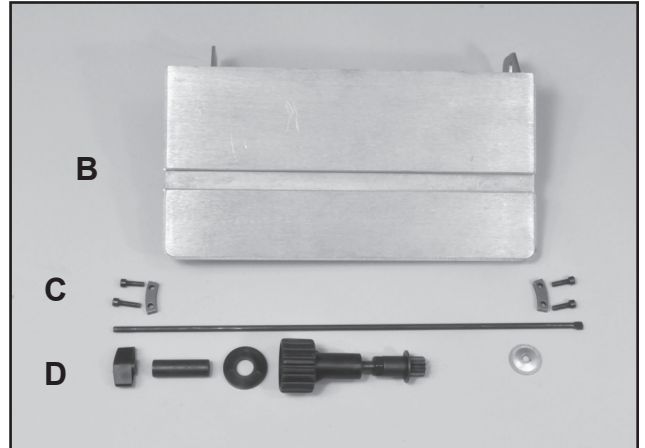

- A. Motor and Base Assembly
- B. Sanding Disc Table
- C. Disc Table Hardware
- D. Disc Table Adjustment Hardware
- E. Sanding Belt Table - Large
- F. Sanding Belt Table - Small
- G. Sanding Belt Table Hardware
- H. Hex Wrench 8MM  
Hex Wrench 2.5MM
- I. Rubber Feet
- J. Miter Gauge
- K. Manual
- L. Steel Stand Components

See pages  
22-24 for full  
Parts Diagrams  
and Parts Lists

Stand Assembly  
Instructions are  
listed on page 25

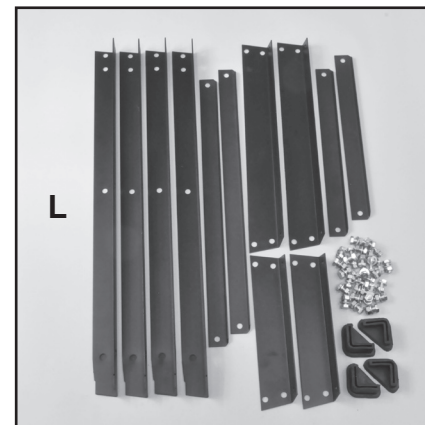

# ASSEMBLY



**WARNING THE SANDER MUST NOT BE PLUGGED IN AND THE POWER SWITCH MUST BE IN THE OFF POSITION UNTIL ASSEMBLY IS COMPLETE.**

## Tools Required for Assembly:

#2 Phillips Screwdriver

10mm or Adjustable Wrench





# ASSEMBLY

**NOTE:** The 50-122 Sander includes a steel stand to mount the sander upon. There are two options for assembling the machine and also the stand:

1- The machine can be assembled first, using a workbench or table surface for this process. Then the stand can be assembled and the sander bolted onto it.

2 - The stand can be assembled first. Then mount the machine to the stand and finish assembling it while it is mounted on the stand.

The following instructions follow the first option listed above.



**THE MACHINE MUST NOT BE PLUGGED IN AND THE POWER SWITCH MUST BE IN THE 'OFF' POSITION UNTIL ASSEMBLY IS COMPLETE.**

## INSTALLING THE FOOT PADS

Four rubber Foot Pads (#29) are supplied to protect your work surface, and to reduce any vibration that may develop when the sander is operating.

1. Tilt the sander up and slide the feet onto each of the four corners of the sander. No hardware is needed. FIG. 1.

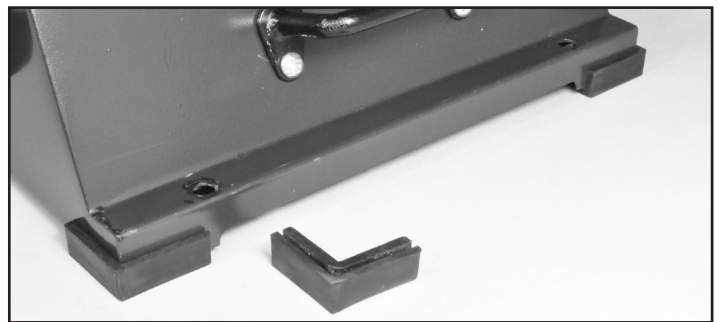

FIG. 1

## INSTALLING THE SANDING BELT FENCES

The sander includes 2 fences for use with the sanding belt. The small Fence/Platen (Part #56, 7-1/4" x 1-3/8") attaches directly to the sanding Belt Frame (#52), and is used for supporting small items being sanded.

The larger Fence/Platen (#55, 8-3/16" x 2-3/16") attaches onto the small fence. It gives a larger support surface for sanding large work pieces.

NOTE: These parts may be pre-assembled at the time of delivery. If not, follow the following parts assembly:

1. Install the small Fence onto the sanding Belt Frame with the 4 Hex Screws and washers (#27, 58). FIG. 2.

2. Insert two star-head Screws (#54) through the countersunk holes in the large Fence and install the Knobs (#57) on their threaded ends. (Washers shown in FIG. 3 are optional, not included with sander).

3. Slide the large fence's 2 screws with knobs over the two slots in the small fence and fasten in place. Pending on the material being sanded, the large fence can easily be removed by just loosening the two knobs and sliding it off the small fence. FIG. 3.

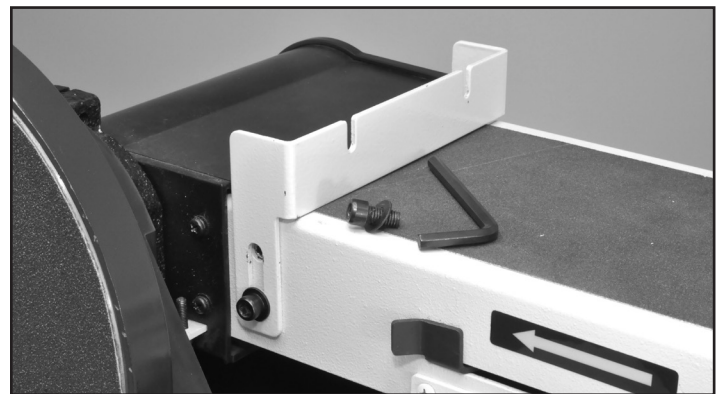

FIG. 2

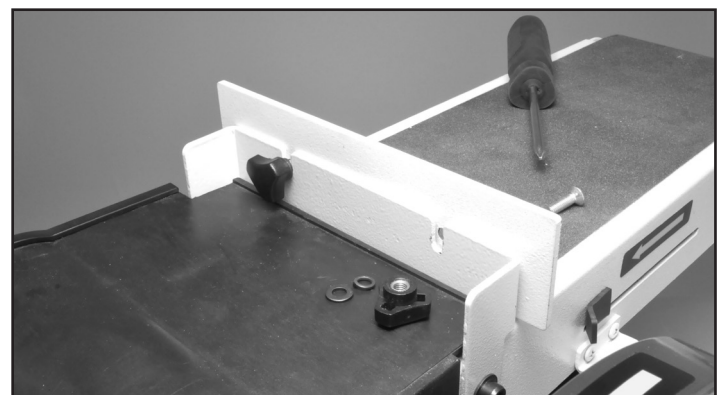

FIG. 3

# ASSEMBLY



## WARNING

THE MACHINE MUST NOT BE PLUGGED IN AND THE POWER SWITCH MUST BE IN THE 'OFF' POSITION UNTIL ASSEMBLY IS COMPLETE.

### MOUNTING PSA SANDPAPER DISCS

**NOTE:** The 50-122 Sander only uses 10" diameter abrasive sanding discs with Pressure Sensitive Adhesive (PSA) backing. To apply the sandpaper:

1. The metal 10" Sanding Disc (#100) is pre-installed on the machine. Locate the sanding Abrasive Disc (#97) and peel the backing off the disc.

2. Center the sandpaper over the disc, then press the sandpaper firmly in place. FIG. 4.

See page 17 for instructions on changing the sandpaper discs.

### INSTALLING THE SANDING DISC TABLE

Partial assembly of the Table's locking knob assembly is first required.

3. Insert the plastic handle Cover (#110) onto the rear of the Table Adjustment Handle (#108).

4. Insert the metal 1-7/8" Sleeve (#109) into the center of the Handle. FIG. 5.

5. Mount the large diameter Washer (#105) onto the long Steel Rod (#85), and slide it down the rod to the rod's flattened end. FIG. 6.

Set the parts of the knob assembly aside at this time.

6. Position the Sanding Disc Table (#40) with the two pre-installed Angle Supports (#5, 88) onto the machined ends of the cast iron disc Frame (#101). FIG. 7.

**NOTE:** The support on the left side should slide under the angle Pointer (#103). This pointer can be unscrewed for the table assembly process, then re-attached at the end of the table mounting.

7. Align the curved slots in the table support with the two threaded holes in each end of the Frame.

8. On each support, position the curved metal Guide Pieces (#87) in the support slots. Fasten each of them in place with two hex Screws (#17A).

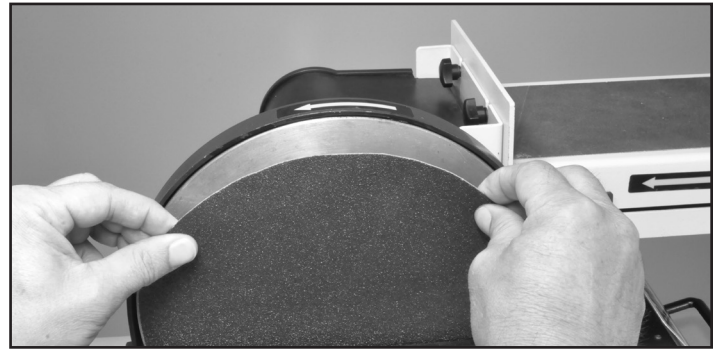

FIG. 4



FIG. 5



FIG. 6

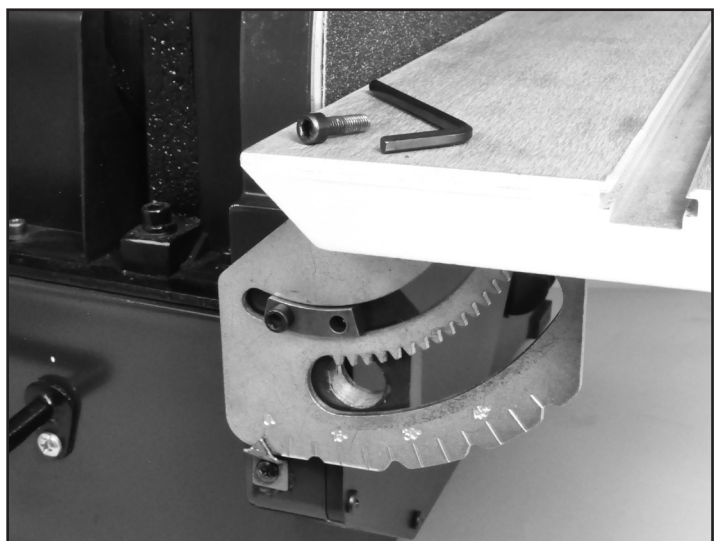

FIG. 7

## ASSEMBLY

9. Insert the steel rod (from step 5) through the lower hole in the right side of the frame. FIG. 8A. The rod should extend under the table to the other end of the frame, where it should exit through the large hole in the left frame. FIG. 8B.

9. Insert the Table Adjustment Handle Assembly (steps 3 & 4) onto the metal rod, and slide its geared end through support plate and into the large hole of the frame's left side. The gears in the handle end should align with the teeth in the left support. FIG. 9.

10. Attach the wing Knob (#111) onto the threaded end of the rod to complete the handle assembly.

**NOTE:** By loosening the knob, the table angle can be adjusted by rotating the handle. To lock the table in position, tighten the knob until the table is secure.

11. The sander's assembly is complete, and the machine can be mounted onto the steel stand, table etc. with bolts or screws (not provided).

**WARNING** Before plugging in and turning on the machine, complete all of the adjustments in the instructions that follow. This will ensure that the sander is correctly set up for safe and efficient operation.

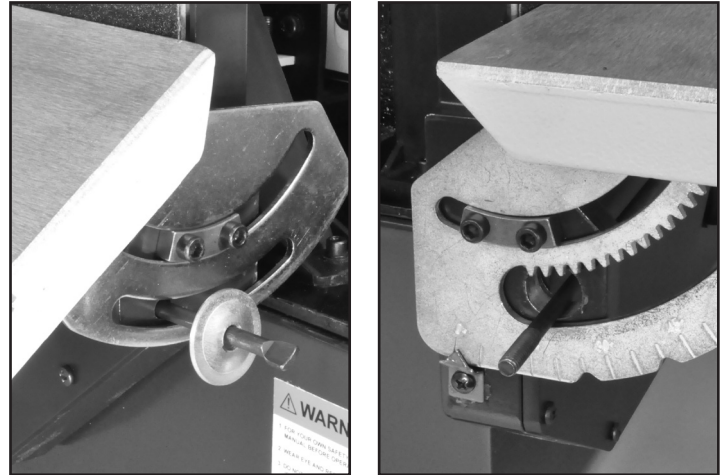

A

FIG. 8

B

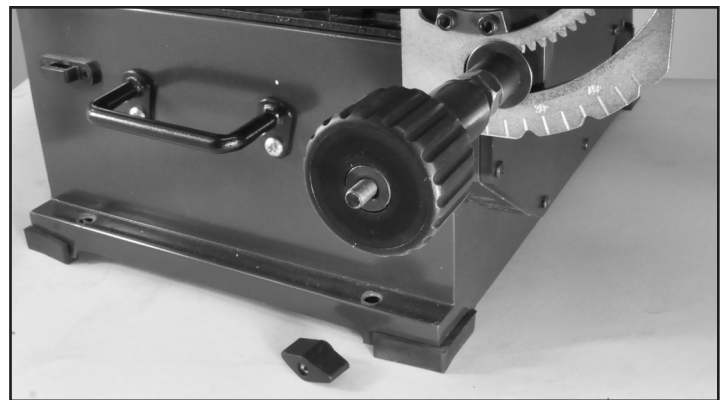

FIG. 9

## ADJUSTMENTS

### DISC TABLE ADJUSTMENTS

Ensure sander is disconnected from the power supply prior to commencing work.

1. To check the trueness of the 90° angle of the disc sanding table, place a square or other measuring device on the table with the other end against the sanding disc. FIG. 10.

2. Loosen the disc table adjustment handle (#111), and adjust table angle to 90°.

3. Re-tighten the disc table adjustment handle.

4. Adjust the Angle Scale Pointer (#103) to 0°.

5. To adjust the disc table to another angle, loosen the disc table adjustment handle.

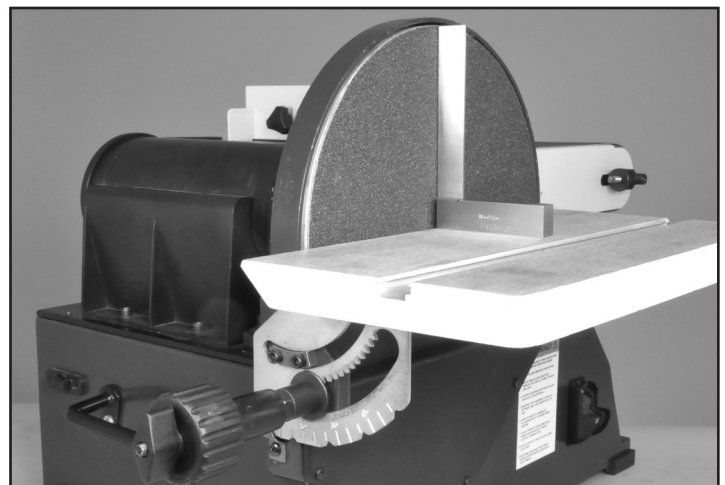

FIG. 10

6. Set the table at the desired angle using the angle scale pointer.

7. Re-tighten the disc table adjustment handle.

CONTINUED ON PAGE 12



# ADJUSTMENTS

**⚠ WARNING** THE MACHINE MUST NOT BE PLUGGED IN AND THE POWER SWITCH MUST BE IN THE OFF POSITION UNTIL ALL ADJUSTMENTS ARE COMPLETE.

## DISC TABLE ADJUSTMENTS CONTINUED

**⚠ WARNING** To avoid jamming the work piece or fingers between the table and sanding surface, the table edge should be set to a maximum of 1/16 inches away from sanding surface. FIG. 11.

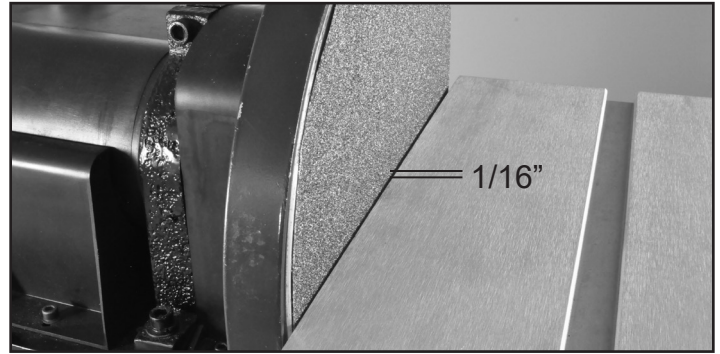

FIG. 11

## SANDING FRAME ADJUSTMENTS

The sanding frame can be easily adjusted from a horizontal position to a vertical position, or any other position to assist your sanding operation.

1. Loosen the Hex Screw (#49) that pulls the split casting together. FIG. 12. This allow the sanding belt frame to be moved to the work angle desired.
2. Once the sanding belt frame is at the desired work angle, re-tighten the hex screw to secure it in place.
3. In the horizontal position, there are two vertical padded Hex Screws (#32) that support the sanding belt frame. These should be checked and adjusted, if necessary, to make sure that they both touch the sanding frame Supports (#51). These screws will help relieve pressure on the casting during work. FIG. 13.

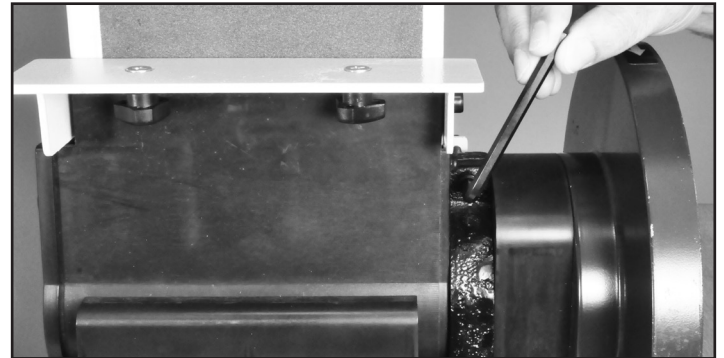

FIG. 12

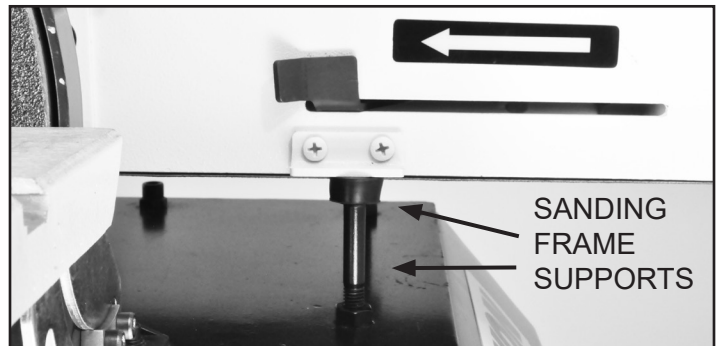

FIG. 13

**⚠ WARNING** Before turning on the machine, review the safety precautions listed on pages 3 to 6. Make sure that you fully understand the features, adjustments and capabilities of the machine that are outlined throughout this manual.

## ON/OFF SWITCH

The On/Off Locking Switch needs to have the safety switch key inserted before the switch can be used. This feature prevents unauthorized use of the sander. FIG. 14.

**CAUTION:** Never walk away from sander when machine is running. Always lock the switch in the Off position and unplug from the power supply when not in use.



FIG. 14

# ADJUSTMENTS



**WARNING**

**THE MACHINE MUST NOT BE PLUGGED IN AND THE POWER SWITCH MUST BE IN THE 'OFF' POSITION UNTIL ASSEMBLY IS COMPLETE.**

## #50-122 DRIVE BELT ADJUSTMENTS

### ADJUSTING THE V-BELT TENSION

Should the rotation of the sanding belt or disc slow down or stall, the cause may be that the V-belt is slipping on the two pulleys. This may be because the motor or frame have become loose from the base, or that the V-belt has stretched out due to the machine being used. In either case, re-adjustment of the V-belt is needed.

1. To gain access to the V-Belt (Part #8), the Belt Cover (#39) must be removed, by unscrewing the two hex head Screws (#112). FIG. 15.

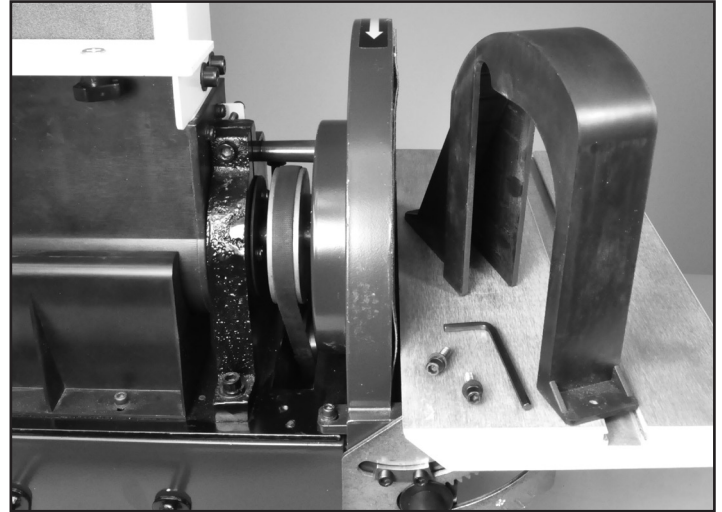

**FIG. 15**

2. On the cabinet top, under the sanding belt frame, there are two hex head Bolts and Nuts (#18, 19) that extend up from the cabinet surface. These connect to the motor frame and will adjust the tension of the V-Belt by pivoting the motor. FIG. 16, A.

Loosen the locking nuts and then rotate the bolts so that the motor frame is moved to put more, or less, tension on the V-Belt.

3. Tension, or the deflection of the V-belt should be about 1/4" to 3/8" when moderate pressure is applied onto the belt with your finger. FIG. 17.

4. Once the proper belt tension is achieved, tighten the hex head bolts to secure the motor frame in its new position.

5. Re-install the safety belt cover over the V-belt, that was removed in step 1 above.

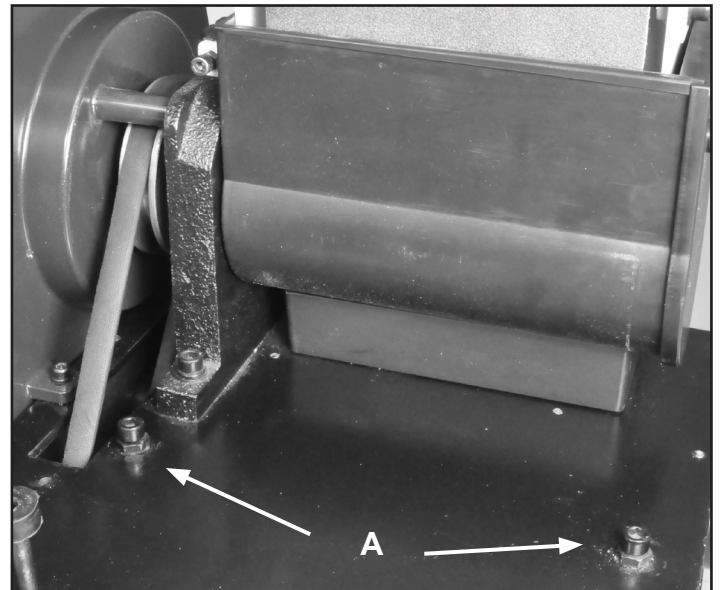

**FIG. 16**

### REPLACING THE V-BELT

Should the rotation of the sanding belt or disc STOP, the cause may be that the V-belt is broken or has stretched out so much, that any tension adjustments do not work. In these cases, the V-belt must be replaced.

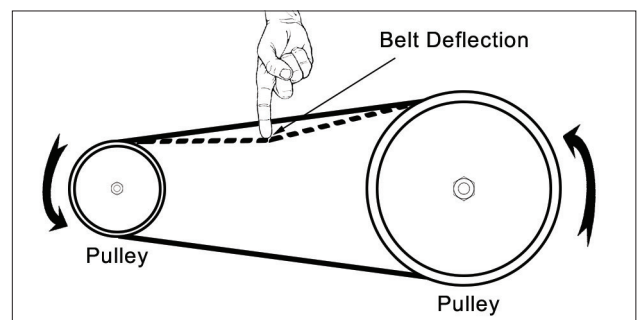

**FIG. 17**

CONTINUED ON PAGE 14



# ADJUSTMENTS



## WARNING

THE MACHINE MUST NOT BE PLUGGED IN AND THE POWER SWITCH MUST BE IN THE 'OFF' POSITION UNTIL ASSEMBLY IS COMPLETE.

### REPLACING THE V-BELT CONTINUED FROM PAGE 13

**NOTE:** Replacing the V-Belt requires that the Belt Cover, bottom Base Cover, and whole Sanding Disc Assembly be removed in order to gain access to the drive shafts and pulleys.

1. Remove the Belt Cover (Part #39) by unscrewing the two hex head Screws (#112). FIG. 18.

2. Remove the complete Sanding Disc Table Assembly from the Disc Frame. FIG. 19.

**NOTE:** Reverse the assembly steps for installing the Sanding Disc Table that are detailed on pages 10 & 11.

3. Remove the lower Disc Guard (#95) by unscrewing the six Phillips head Screws (#33A), and also the Sandpaper from the metal Sanding Disc. FIG. 20.

4. Remove the metal Sanding Disc (#100). Turn the center Screw (#98) counterclockwise to remove it. Pull the large Washer (#99) from the disc center and then pull the disc off from the Drive Shaft (#24). Note that the disc is positioned on the shaft with a small Key (#11). FIG. 21.

5. Remove the Dust Connection Pipe (#102) from the lower section of the Disc Frame with the four Phillips head Screws (#33A). FIG. 21.

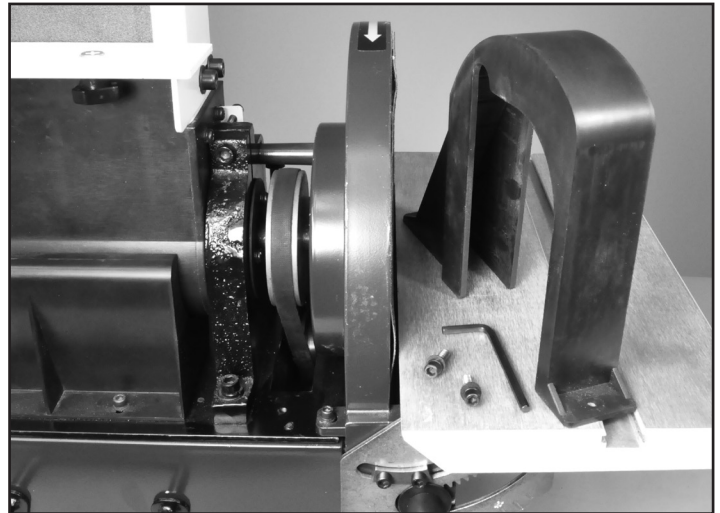

FIG. 18



FIG. 19



FIG. 20

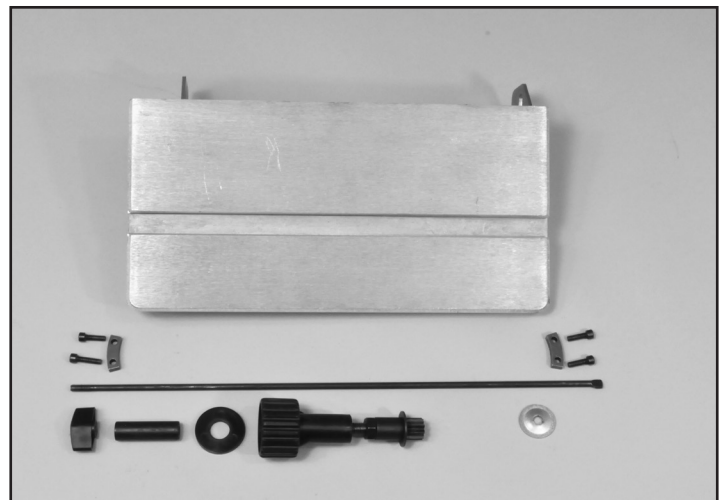

FIG. 21

## ADJUSTMENTS

**⚠ WARNING** THE MACHINE MUST NOT BE PLUGGED IN AND THE POWER SWITCH MUST BE IN THE OFF POSITION UNTIL ALL ADJUSTMENTS ARE COMPLETE.

6. Unscrew the Disc Frame from the sander's cabinet. Remove three screws - two on top of the frame (#38) and one longer screw from the interior of the frame (#91A). FIG. 22.

7. On the cabinet top, under the sanding belt frame, there are two hex head Bolts and Nuts (#18, 19) that extend up from the cabinet surface. These connect to the motor frame and will adjust the tension of the V-Belt by pivoting the motor. FIG. 16, A , page 13.

Loosen the locking nuts and then rotate the bolts so that the motor frame is moved to release tension on the V-Belt.

To gain access to the lower drive Pulley and V-Belt, the bottom Base Cover (#3) must be removed.

7. Carefully tip the sander to one side to avoid any damage to the machine. Unscrew the four retaining Screws (#1) and remove the base cover. FIG. 23.

**NOTE:** For clarity, FIG. 24 is a bottom view of the sander with the base cover removed. It shows the motor, V-belt and pulleys.

8. Remove the old V-belt from the two drive pulleys, and install a new V-Belt. Make sure that there is some tension on the belt, so that it does not slip off as the sander parts are re-assembled.

**NOTE:** Both pulleys are pre-set at the factory and should be in-line with each other. If not, re-adjust one of the pulleys on their drive shaft. Loosen the hex set screw that holds the pulley to its shaft, move the pulley so that it is aligned with the other pulley, then re-tighten the set screw to lock it in position.

9. While the sander is still apart, set the belt tension. See page 13 for instructions on tightening the two bolts that apply belt tension. FIG. 17. The sander will have to be tipped back up to its normal position for this step.

10. Once the tension on the V-belt is set, re-assemble the sander parts by reversing steps 7 to 1 above.

The sander is now ready to plug in and use again.

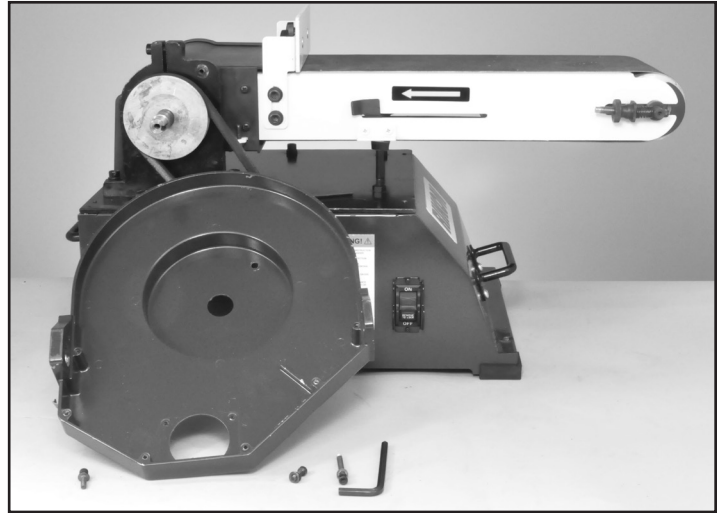

FIG. 22

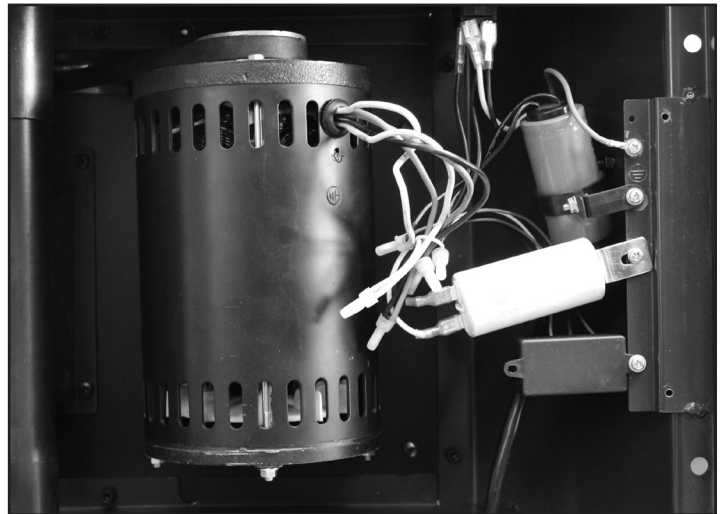

FIG. 23



FIG. 24

# OPERATION

## CHANGING THE SANDING BELT

1. Remove the plastic Side Cover (#60) from the frame by unscrewing the knob (#78). FIG. 25.
2. Remove the Small Fence (#56). See page 9 for instructions on installing this part.
3. Slide Tension Lever (#71) to the right to release the belt tension. FIG. 26.

**NOTE:** Above the Tension Lever, there is a direction arrow. The sanding belt must run in the direction of this arrow so that the splice does not come apart. FIG. 26.

4. Remove the old belt by sliding it off to the left of the frame. Place the new sanding belt over the drums with the direction arrow pointing in the proper direction. See FIG. 27. Make sure the belt is centered on both drums.
5. Slide the tension lever to the left to apply tension to the belt. FIG. 26.
6. Re-install the small fence and side cover onto the frame (removed in Step 1 & 2).

7. Plug in the power cord. Turn the switch "ON" and note if the belt tends to move to the right or left on the drums. The belt should be running on the center of the drive drums. If it is not, the belt tracking needs adjustment. See below for instructions on tracking.

## SANDING BELT TRACKING

8. Belt tracking on the center of the drive wheels is pre-set at the factory. If an adjustment need to be made, the sander must be turned on. FIG. 28.
9. - If the sanding belt moves toward the disc, slowly turn the Tracking Knob (#66) clockwise 1/4 turn.  
- If the sanding belt moves away from the disc, turn the tracking knob slowly counterclockwise 1/4 turn.
10. Slowly turn the belt tracking knob noting the belt movement. Re-adjust the tracking knob, as necessary, until the belt runs true in the center of the drums.

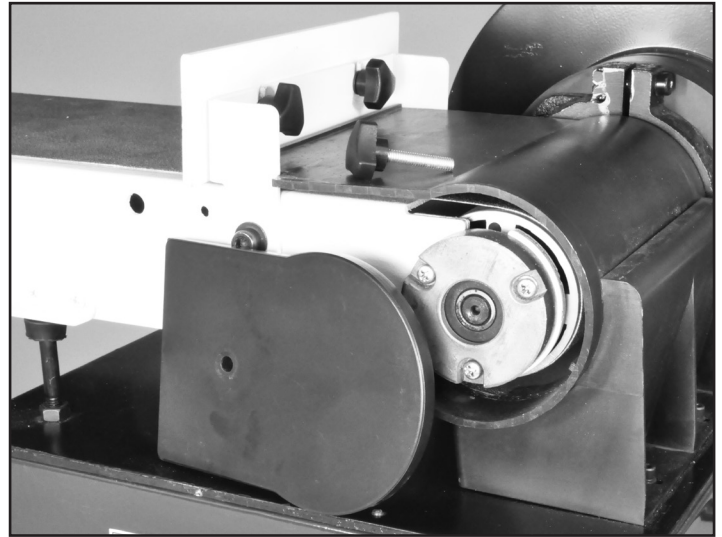

FIG. 25



FIG. 26

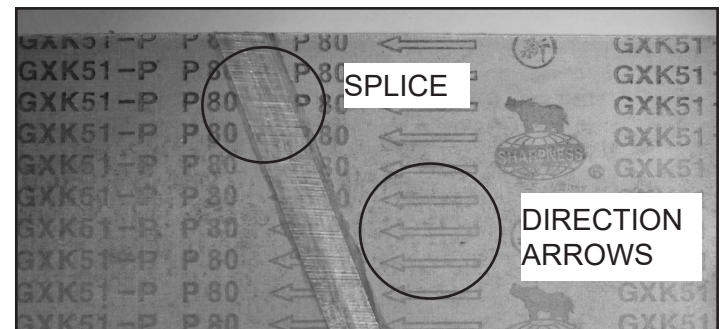

FIG. 27

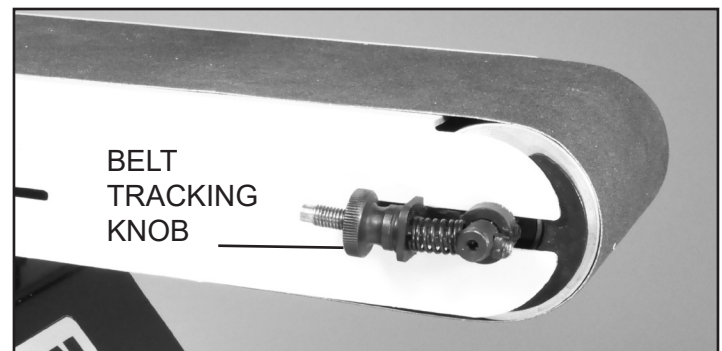

FIG. 28



# OPERATION

## CHANGING THE SANDING DISC

The sandpaper disc can be removed with the table installed, FIG. 29, or with the table removed to give more working access to the disc, if needed. See pages 10 & 11 for table instructions.

1. Peel the used abrasive disc from the metal sanding disc plate. A putty knife may help in this process.
2. Make sure that the disc plate is clean of any residue. Mineral spirits will soften the PSA adhesives for its removal. Rotate the disc by hand may be necessary to get access to all of the disc surface.
3. Peel the protective backing from the new PSA 10" abrasive sanding disc, then center and press the sanding disc firmly onto the disc plate. See page 10.
4. Replace the sanding table if it was removed.

**⚠ WARNING** THE MACHINE MUST NOT BE PLUGGED IN AND THE POWER SWITCH MUST BE IN THE OFF POSITION UNTIL ALL ADJUSTMENTS ARE COMPLETE.

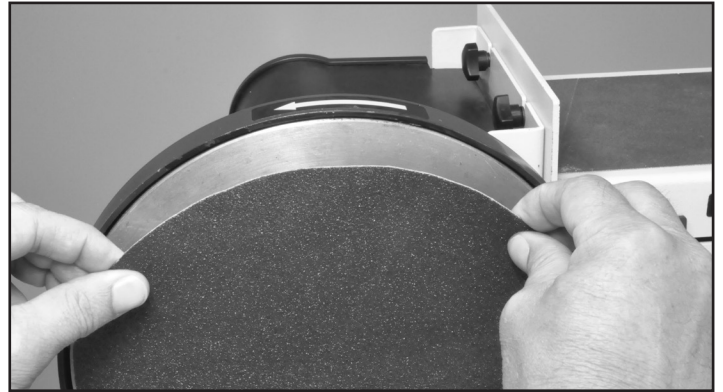

FIG. 29

**NOTE:** Hook & Loop sanding discs cannot be used with this sander! Only 10" sanding discs with pressure sensitive adhesive (PSA) backing can be used.

## DISC SANDING

**⚠ WARNING:** When sanding, always position your work on the downward, rotating side (left side) of the sanding disc. FIG. 30. The sanding action will then force the wood down, safely towards the table, where it can be controlled. Sanding on the right, upward rotating side of the disc is dangerous, as your work cannot be controlled and 'kick-back' may occur - the wood being forced up and out of your hands.

1. Depending on your work, set the Sanding Disc Table to the proper angle from 45° to 90°. FIG. 30, 31.
2. Once the table has been set for the correct sanding angle, and all fasteners are secure, the machine can be plugged in for operation.
3. Use the Miter Gauge (#80) for added control of the work piece during sanding. The miter gauge can also be set to various degree angles for maintaining accurate angles when sanding small or multiple parts.
4. Do not force the work piece into the sanding disc. Sand using light pressure, letting the sanding abrasives time to do their work!
5. Move your work piece slightly left and right on the disc, keeping to the left-of-center, downward side. Moving your work piece left and right on the disc will

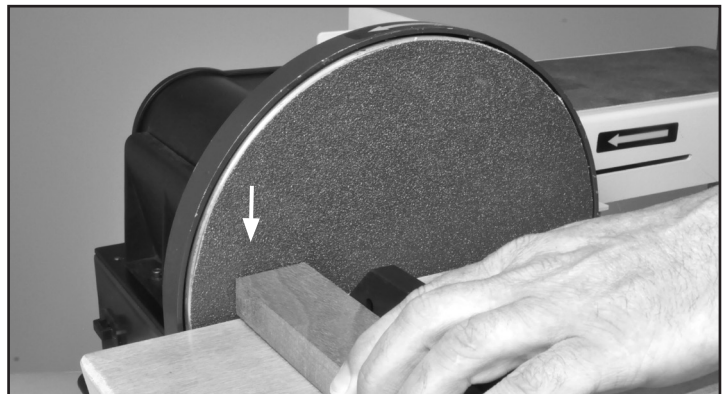

FIG. 30



FIG. 31

help prevent resin or debris from building up on one area of the disc, and also helps to prevent burning of the sanded surface from excessive abrasive-action heat build-up.

## OPERATION

### MITER GAUGE

The Miter Gauge (#110) can be used on the disc table, which has a slot to fit the miter gauge's bar. The miter gauge head can be set anywhere up to 45° (right or left) by loosening the lock-knob, setting the miter gauge head to the desired angle, and retightening the lock-knob. FIG. 32.

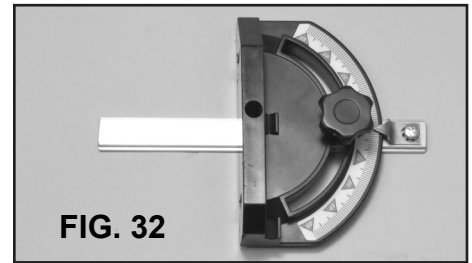

### BELT SANDING

Always ensure the sander is unplugged prior to attempting any assembly, installation or changing of parts and accessories.

Position the sanding belt bed horizontally or vertically as needed for your sanding needs. See page 12. Once the correct sanding angle, and all fasteners are secure, the sander can be plugged in for operation.

**Warning:** To avoid injury from slips, jams or thrown pieces, adjust the sanding belt fence (#56) to clear the sanding surface by no more than 1/16th of an inch.

1. Hold the work piece firmly, keeping fingers away from the sanding belt.
2. Keep the work piece against the backstop and move it evenly across the sanding belt. Use extra caution when sanding very thin pieces. FIG. 33 & 34.
3. For sanding long pieces, remove the fence.
4. Do not force the work piece into the sanding belt. Sand using light pressure, letting the sanding abrasives time to do their work!
5. Move your work piece slightly left and right on the belt. This will help prevent resin or debris from building up on one area of the belt, and also helps to prevent burning of the sanded surface from excessive abrasive-action heat build-up.

### SANDING CURVED EDGES

Sanding *inside* curves on your work piece and be done on the idler drum as shown. FIG. 35.

Always sand *outside* curves on your work piece with the sanding belt in vertical position, using the belt's fence for support. FIG. 34. Or sand your work on the left side of center on the sanding disc. FIG. 30 & 31.

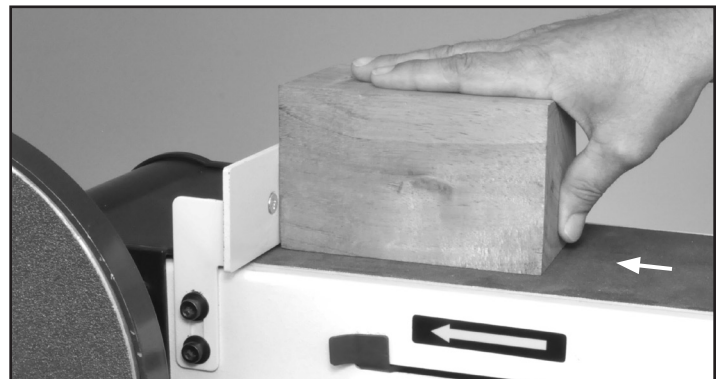

FIG. 33



FIG. 34



FIG. 35

**WARNING:** Never attempt to sand the ends of a work piece on the idler drum, as this could cause the work piece to fly up and result in an injury. Use the end of the idler drum for freehand sanding on long, side grain work pieces as shown in FIG 35.



# MAINTENANCE

**WARNING:** Turn the power switch “OFF” and disconnect the plug from the outlet prior to adjusting or maintaining the sander. DO NOT attempt to repair or maintain the electrical components of the motor. Take the sander to a qualified service technician for this type of maintenance.

## MAINTENANCE REQUIRED

1. Check the power cord and plug for any damage.
2. Check sanding belts and discs for damage or wear.
3. Check all guards and hardware to make sure they are secure.
4. Check all moving parts for alignment and binding issues.
4. Dress/Clean sanding surfaces for best abrasive action.
5. Replace sanding belts or discs when worn or damaged.
6. Clean and vacuum dust from the motor housing and other sander parts.
7. Keep iron tables free of rust. Apply coat of paste wax or silicon spray.

## FREQUENCY

- Before each use.
- Before each use.
- Before each use.
- Before each use.
- As needed
- As needed.
- As needed.

**NOTE:** Lubrication of the bearings is not necessary, as they are sealed and pre-lubricated for life. Just replace a bearing if failure occurs. Do not use compressed air near bearings. Simply wipe the exposed bearing surfaces with a dry cloth to clean them.

**WARNING:** If blowing sawdust, wear proper eye protection to prevent debris from blowing into eyes.

**Service beyond recommended maintenance on these tools should only be performed by an authorized, qualified technician.**

## WIRING DIAGRAM

**WARNING:**

This machine must be grounded. Replacement of the power supply cable should only be done by a qualified electrician.

This tool is intended for use on a circuit that has a 120 volt electrical receptacle. The illustration on page 5 shows the type of the 120v, 3-wire electrical plug and electrical receptacle that has a grounding conductor that is required.

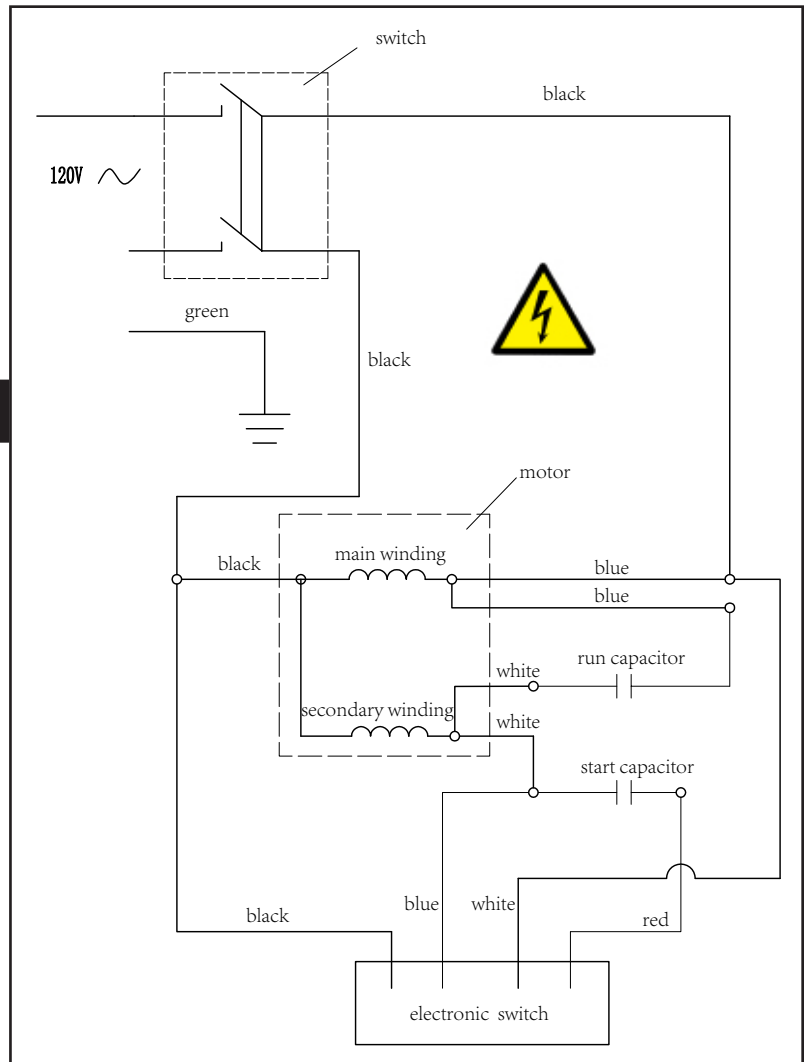

# TROUBLESHOOTING

Service on these tools should only be performed by an authorized, qualified technician.

SYMPTOM	PROBABLE CAUSE	CORRECTIVE ACTION
Motor will not start.	<ol style="list-style-type: none"> <li>1. Low voltage</li> <li>2. Open circuit in motor or loose connections.</li> <li>3. Blown fuse or breaker.</li> </ol>	<ol style="list-style-type: none"> <li>1. Check power source for proper voltage.</li> <li>2. Inspect all lead connections on motor for loose or open connections. (Send for Servicing.)</li> <li>3. Short circuit. (Send for Servicing.)</li> <li>4. Improper match between tool and circuit, fuse or breaker.</li> </ol>
Motor will not start – fuses or circuit breakers tripping or blowing.	<ol style="list-style-type: none"> <li>1. Short circuit in line, cord or plug.</li> <li>2. Short circuit in motor or loose connections.</li> <li>3. Incorrect fuses or circuit breakers in power line.</li> </ol>	<ol style="list-style-type: none"> <li>1. Inspect cord or plug for damaged insulation and shorted wires.</li> <li>2. Inspect all connections on motor for loose or shorted terminals and/or worn insulation.</li> <li>3. Install correct fuses or circuit breakers or switch tool to an appropriately sized circuit.</li> </ol>
Motor overheats.	<ol style="list-style-type: none"> <li>1. Motor is overloaded.</li> <li>2. Extension cord is too long and of insufficient gauge (weight).</li> <li>3. Poor air circulation around the motor</li> </ol>	<ol style="list-style-type: none"> <li>1. Reduce load on motor (pressure on the sandpaper from the object being sanded.)</li> <li>2. Utilize an extension cord of appropriate gauge and length or plug tool directly into outlet.</li> <li>3. Reduce the motor run time.</li> </ol>
Motor stalls or runs slow - resulting in blown fuses or tripped circuit.	<ol style="list-style-type: none"> <li>1. Motor is overloaded.</li> <li>2. Short circuit in the motor or loose connections.</li> <li>3. Low line voltage.</li> <li>4. Incorrect fuses or circuit breakers in the power line.</li> <li>5. Motor capacitor has failed.</li> <li>6. Belt tension is too tight.</li> </ol>	<ol style="list-style-type: none"> <li>1. Reduce the load on the motor.</li> <li>2. Inspect connections on motor for loose or shorted terminals or worn insulation.</li> <li>3. Correct low voltage conditions (for example: improper extension cord length and/or wire gauge).</li> <li>4. Install <b>CORRECT</b> fuses or circuit breakers or plug tool into an appropriate circuit, matched to an appropriate fuse or breaker.</li> <li>5. Replace motor capacitor.</li> <li>6. Decrease belt tension.</li> </ol>
Machine slows down when operating.	<ol style="list-style-type: none"> <li>1. Feed rate is too great.</li> <li>2. Undersized circuit or use of undersized extension cord.</li> </ol>	<ol style="list-style-type: none"> <li>1. Reduce the rate at which the work is fed into the sandpaper.</li> <li>2. Ensure circuit wires or extension cords are proper gauge, or eliminate use of extension cords.</li> </ol>
Machine vibrates excessively or makes excess noise.	<ol style="list-style-type: none"> <li>1. Incorrect motor mounting.</li> <li>2. Incorrect sanding-belt tension.</li> <li>3. Weak or broken belt tension spring.</li> <li>4. Idler roller is too loose.</li> <li>5. Broken/defective sanding belt or disc.</li> <li>6. Drive belt is too tight</li> </ol>	<ol style="list-style-type: none"> <li>1. Make sure all fasteners are tightened.</li> <li>2. Adjust tension-adjustment knob. Follow belt tensioning/tracking instructions in this manual.</li> <li>3. Replace belt tension spring by service technician.</li> <li>4. Have service technician adjust idler roller.</li> <li>5. Replace sanding belt/disc.</li> <li>6. Decrease belt tension.</li> </ol>

# TROUBLESHOOTING

SYMPTOM	PROBABLE CAUSE	CORRECTIVE ACTION
Burn marks on work piece.	<ol style="list-style-type: none"> <li>Using a sanding grit that is too fine.</li> <li>Using too much pressure.</li> <li>Work held still for too long against the sandpaper.</li> </ol>	<ol style="list-style-type: none"> <li>Use a coarser-grit sandpaper.</li> <li>Reduce work piece pressure on the sandpaper while sanding.</li> <li>Do not keep the work piece sanding in one place for too long.</li> </ol>
Deep sanding grooves or scars in work piece.	<ol style="list-style-type: none"> <li>Sanding belt/disc grit is too coarse for the desired finish.</li> <li>Work piece is being sanded across the grain.</li> <li>Too much sanding force on the work piece.</li> <li>Work piece held still against the belt-disc for too long.</li> </ol>	<ol style="list-style-type: none"> <li>Use a finer-grit sanding belt or disc.</li> <li>Sand with the grain of the wood.</li> <li>Reduce pressure on work piece while sanding.</li> <li>Keep work piece moving while sanding.</li> </ol>
Sanding surface clogs quickly.	<ol style="list-style-type: none"> <li>Too much pressure against the belt or disc.</li> <li>Sanding softwood or highly resinous woods.</li> </ol>	<ol style="list-style-type: none"> <li>Reduce pressure on work piece while sanding.</li> <li>Use different stock, sandpaper grits, or accept that this will happen and plan on cleaning or replacing belts &amp; discs frequently.</li> </ol>
Sanding grains easily rub off the belt or disc.	<ol style="list-style-type: none"> <li>Sandpaper has been stored in an incorrect environment.</li> <li>Sandpaper has been damaged or folded.</li> </ol>	<ol style="list-style-type: none"> <li>Ensure sandpaper is stored away from extremely hot &amp; dry or damp/humid conditions.</li> <li>Store sanding accessories flat – not bent or folded.</li> </ol>
Work piece lifts up from the sanding disc-table.	<ol style="list-style-type: none"> <li>Sanding on the “up” , right side of the disc, where rotation is up and away from the table.</li> </ol>	<ol style="list-style-type: none"> <li>Sand on the left side of the disc, where the disc rotates down towards the table.</li> </ol>

For parts or technical questions contact: [techsupport@rikontools.com](mailto:techsupport@rikontools.com) or 877-884-5167.

# ACCESSORIES

## SANDING BELTS

6" x 48" Aluminum Oxide



<b>50-6080</b>	80 Grit *	Pack of 2
<b>50-6120</b>	120 Grit	Pack of 2
<b>50-6150</b>	150 Grit *	Pack of 2
<b>50-6180</b>	180 Grit	Pack of 2
<b>50-6220</b>	240 Grit *	Pack of 2
<b>50-6999</b>	Assortment	Pack of 6
* 2 each 3 grits 80,150 & 240		

## SANDING DISCS

10" Diameter, PSA,  
Aluminum Oxide



<b>50-10060</b>	60 Grit	Pack of 2
<b>50-10080</b>	80 Grit *	Pack of 2
<b>50-10120</b>	120 Grit *	Pack of 2
<b>50-10180</b>	180 Grit	Pack of 2
<b>50-10220</b>	240 Grit *	Pack of 2
<b>50-10999</b>	Assortment	Pack of 6
* 2 each 3 grits 80, 120 & 240		

# PARTS DIAGRAM

## 50-122 BELT & DISC SANDER ASSEMBLY

**NOTE:** Please reference the Manufacturer's Part Number when calling for Replacement Parts. For Parts under Warranty, the Serial Number of your machine is required.

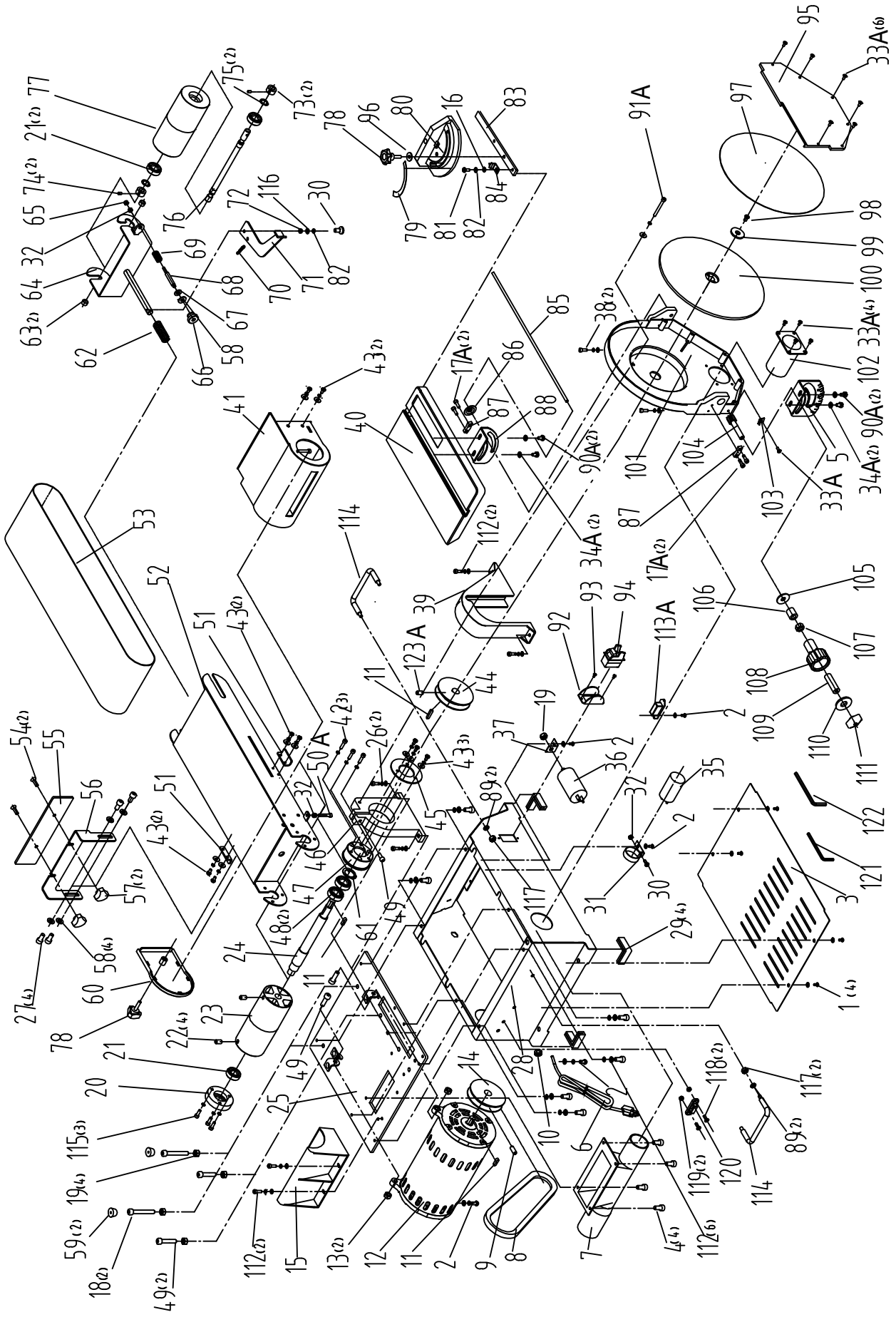

# PARTS LIST

KEY NO.	DESCRIPTION	QTY	PART NO.	KEY NO.	DESCRIPTION	QTY	PART NO.
1	Star-head screw & washer M4x6	4	P50-122-1	63	Bushing	2	P50-122-63
2	Star-head screw & washer M4x8	5	P50-122-2	64	Driven drum support	1	P50-122-64
3	Base cover	1	P50-122-3	65	Special nut M5	1	P50-122-65
4	Star-head screw M5x8	4	P50-122-4	66	Belt tracking knob M8	1	P50-122-66
5	Left angle scale	1	P50-122-5	67	Rubber washer	1	P50-122-67
6	Power cord	1	P50-122-6	68	Adjust rod	1	P50-122-68
7	Dust collection port	1	P50-122-7	69	Adjust spring	1	P50-122-69
8	Belt A580	1	P50-122-8	70	Spring 2	1	P50-122-70
9	Hex head screw M6x8	1	P50-122-9	71	Belt tension handle	1	P50-122-71
10	Strain relief 6P4	1	P50-122-10	72	Powder metal bushing	1	P50-122-72
11	Key A5x15	3	P50-122-11	73	Position ring for driven shaft	2	P50-122-73
12	Motor	1	P50-122-12	74	Hex position screw M5x6	2	P50-122-74
13	Special nut M8	2	P50-122-13	75	Spring washer for shaft D12	2	P50-122-75
14	Drive pulley	1	P50-122-14	76	Driven shaft	1	P50-122-76
15	Dust collection cover	1	P50-122-15	77	Driven drum	1	P50-122-77
16	Plain washer D5	1	P50-122-16	78	Miter gauge knob	2	P50-122-78
17A	Hex head screw M5x16	4	P50-122-17A	79	Miter gauge label	1	P50-122-79
18	Hex head screw M8x55	2	P50-122-18	80	Miter gauge	1	P50-122-80
19	Hex nut M8	5	P50-122-19	81	Hex head screw M5x8	1	P50-122-81
20	Bearing cap	1	P50-122-20	82	Lock washer D5	1	P50-122-82
21	Bearing 6201	3	P50-122-21	83	Miter gauge bar	1	P50-122-83
22	Hex head screw M8x12	4	P50-122-22	84	Miter gauge pointer	1	P50-122-84
23	Drive drum	1	P50-122-23	85	Steel rod	1	P50-122-85
24	Drive shaft	1	P50-122-24	86	Stop washer	1	P50-122-86
25	Base top plate	1	P50-122-25	87	Curved guide piece	2	P50-122-87
26	Screw, spring & flat washer M8x30	2	P50-122-26	88	Right angle scale	1	P50-122-88
27	Hex head screw M8x16	4	P50-122-27	89	Spring washer D6	4	P50-122-89
28	Base	1	P50-122-28	90A	Hex head bolt M6x8	4	P50-122-90A
29	Feet	4	P50-122-29	91A	Hex head screw M5x56	1	P50-122-91A
30	Star head screw M5x16	2	P50-122-30	92	Switch guard	1	P50-122-92
31	Capacitor support 1	1	P50-122-31	93	Star-head screw M3x10	2	P50-122-93
32	Hex nut M5	3	P50-122-32	94	On/Off Switch & safety key HY7	1	P50-122-94
33A	Star-head screw M4x12	11	P50-122-33A	95	Disc guard	1	P50-122-95
34A	Flat washer D6	4	P50-122-34A	96	Big washer D6	1	P50-122-96
35	Capacitor 1	1	P50-122-35	97	Sanding disc PSA paper 10"	1	P50-122-97
36	Capacitor 2	1	P50-122-36	98	Star-head screw M6x20	1	P50-122-98
37	Capacitor support 2	1	P50-122-37	99	Washer for disc assembly	1	P50-122-99
38	Hex head screw & washers M5x18	2	P50-122-38	100	Disc 8"	1	P50-122-100
39	Belt cover	1	P50-122-39	101	Disc cover	1	P50-122-101
40	Work table for disc	1	P50-122-40	102	Dust connection pipe	1	P50-122-102
41	Belt rear cover	1	P50-122-41	103	Pointer	1	P50-122-103
42	Star screw & lock washer M5x25	3	P50-122-42	104	Gear shaft	1	P50-122-104
43	Star screw & washer M5x12	9	P50-122-43	105	Big washer D10	1	P50-122-105
44	Driven pulley	1	P50-122-44	106	Long bushing	1	P50-122-106
45	Fixing ring	1	P50-122-45	107	Nut M10	1	P50-122-107
46	Belt frame assembly base	1	P50-122-46	108	Table angle adjust handle	1	P50-122-108
47	Bearing cap	1	P50-122-47	109	Sleeve	1	P50-122-109
48	Ball bearing 6202	2	P50-122-48	110	Plastic Cover for handle	1	P50-122-110
49	Hex head screw M8x30	5	P50-122-49	111	Knob for table lock	1	P50-122-111
50A	Hex head screw M5x30	1	P50-122-50A	112	Hex head screw & washer M5x10	10	P50-122-112
51	Belt frame support	2	P50-122-51	113A	Electronic centrifugal switch	1	P50-122-113A
52	Belt frame	1	P50-122-52	114	Steel handle	2	P50-122-114
53	Sanding belt 6" x 48"	1	P50-122-53	115	Star screw & spring washer M5x16	3	P50-122-115
54	Star-head screw M6x14	2	P50-122-54	116	Big washer D5	1	P50-122-116
55	Assist fence	1	P50-122-55	117	Hex nut M6	4	P50-122-117
56	Fence for sanding belt	1	P50-122-56	118	Hex head screw M5x10	2	P50-122-118
57	Knob M6	2	P50-122-57	119	Hex nut M5	2	P50-122-119
58	Plain washer D8	5	P50-122-58	120	Wrench holder	1	P50-122-120
59	Rubber foot	2	P50-122-59	121	Hex wrench 6mm	1	P50-122-121
60	Side cover	1	P50-122-60	122	Hex wrench 4mm	1	P50-122-122
61	Spring washer for shaft D14	1	P50-122-61	123A	Hex head screw M6x16	1	P50-122-123A
62	Spring 1	1	P50-122-62				



# PARTS DIAGRAM & PARTS LIST

## STAND FOR 50-122 SANDER

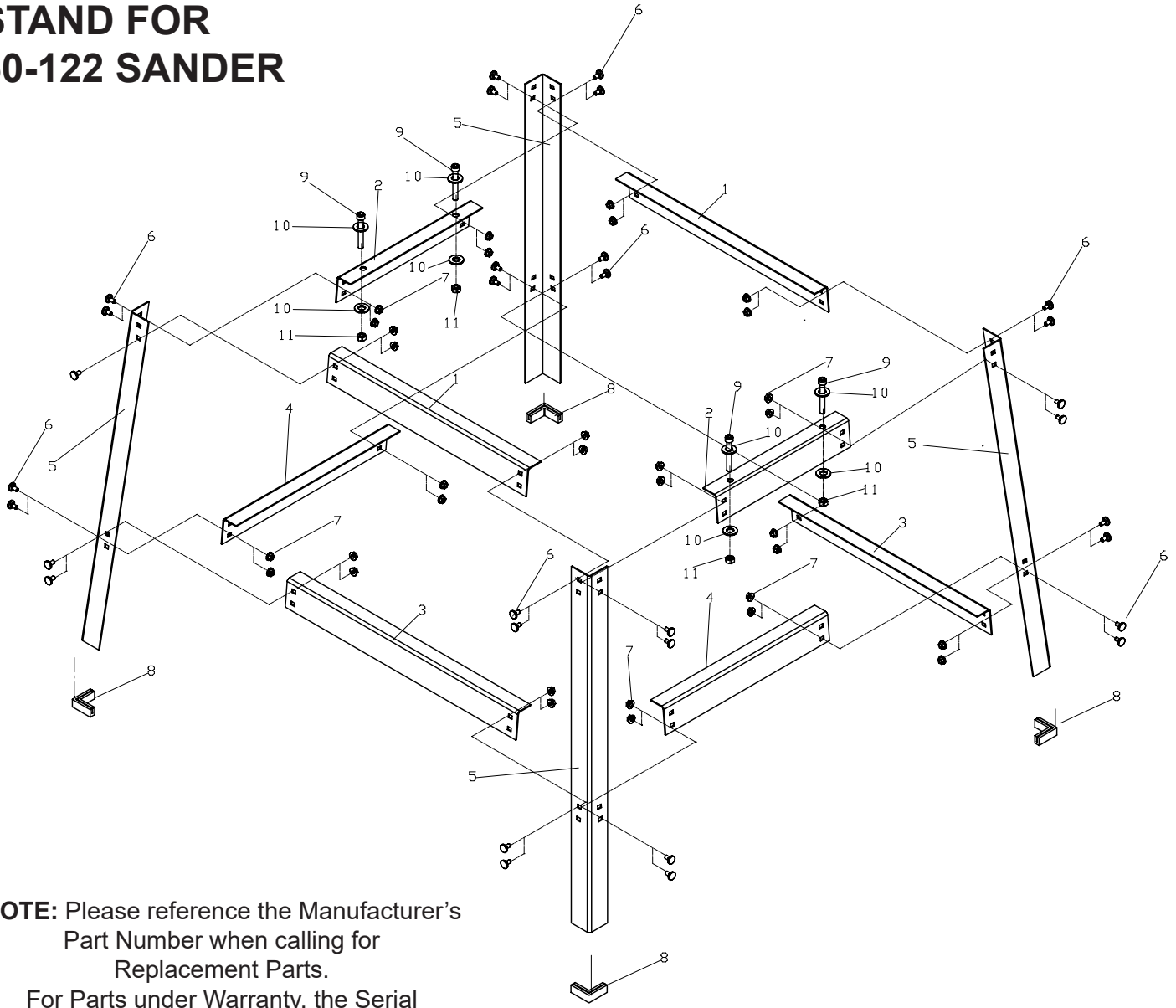

**NOTE:** Please reference the Manufacturer's Part Number when calling for Replacement Parts.  
For Parts under Warranty, the Serial Number of your machine is required.

KEY NO.	DESCRIPTION	QTY.	MFG. PART NO.
1	Upper Long Rail	2	P50-122-1S
2	Upper Short Rail	2	P50-122-2S
3	Lower Long Rail	2	P50-122-3S
4	Lower Short Rail	2	P50-122-4S
5	Leg	4	P50-122-5S
6	Bolt M6x12	32	P50-122-6S
7	Hex Nut M6	32	P50-122-7S
8	Rubber Foot Pad	4	P50-122-8S
9	Hex Screw M8x55	4	P50-122-9S
10	Flat Washer 8	8	P50-122-10S
11	Hex Nut M8	4	P50-122-11S

# ASSEMBLY

## STAND ASSEMBLY

1. Connect leg (#5) with the upper long bar (#1) with two nuts and bolts (#6 & 7). FIG. 1.

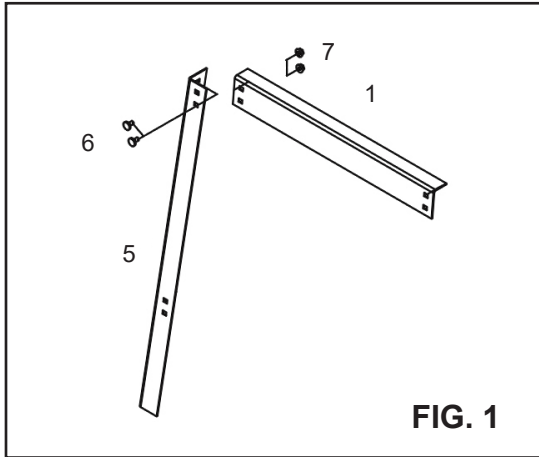

2. Connect another leg (#5) to the other end of the upper long bar (#1) in step 1. FIG. 2.

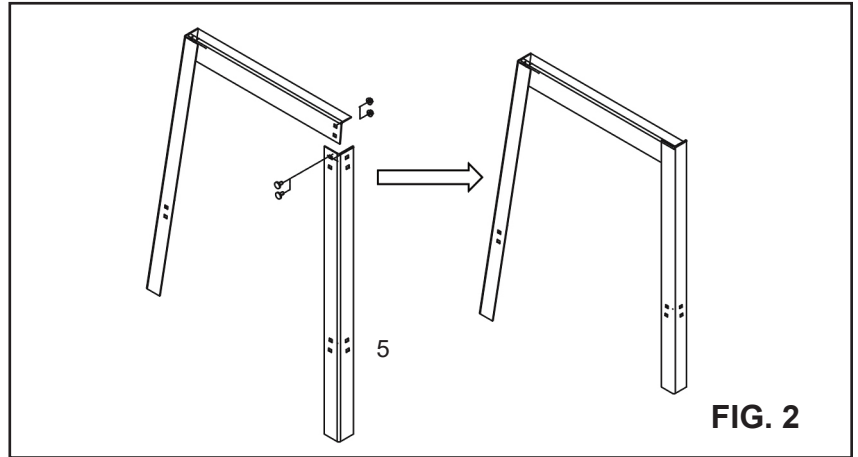

3. Assemble the lower long bar (#3) to the pair of legs with nuts and bolts. FIG. 3. This completes the assembly of one side of the stand.

4. Repeat steps 1-3 to assemble a second side of the stand.

5. Connect the two sides of the stand together. Assemble the lower short bar (#4) and the upper short bar (#2) to the long legs. FIG. 4.

6. Repeat step 5 to assemble the remaining side of the stand. Assemble the lower short bar (#4) and the upper short bar (#2) to the long legs.

7. With the stand assembled, fit the four rubber foot pads (#8). FIG. 5.

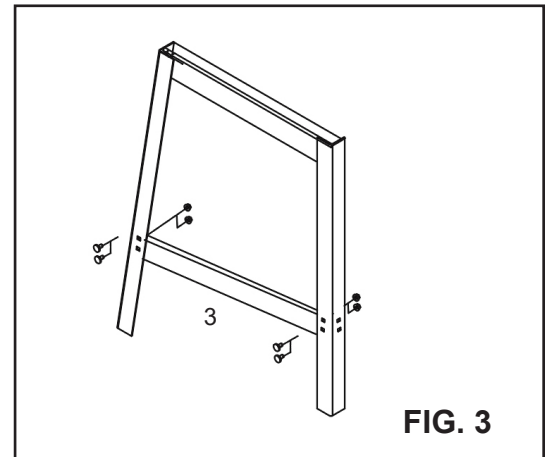

8. Screws, washers and nuts (#9, 10, 11) are supplied to finally mount the sander onto the stand for use.

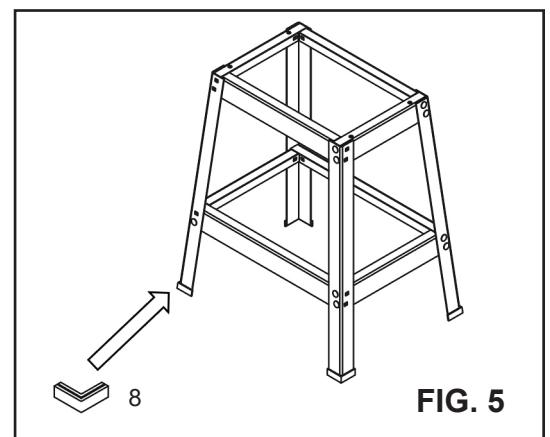
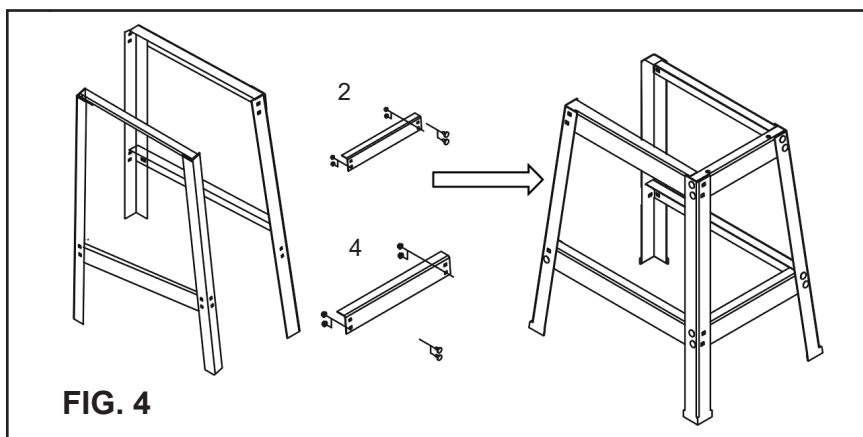

**NOTES**

Use this section to record maintenance, service and any calls to Technical Support:

Lined area for recording notes, consisting of multiple horizontal lines.

# RIKON

## POWER TOOLS®

### 5-Year Limited Warranty

RIKON Power Tools Inc. (“Seller”) warrants to only the original retail consumer/purchaser of our products that each product be free from defects in materials and workmanship for a period of five (5) years from the date the product was purchased at retail. This warranty may not be transferred.

This warranty does not apply to defects due directly or indirectly to misuse, abuse, negligence, accidents, repairs, alterations, lack of maintenance or normal wear and tear. Under no circumstances will Seller be liable for incidental or consequential damages resulting from defective products. All other warranties, expressed or implied, whether of merchantability, fitness for purpose, or otherwise are expressly disclaimed by Seller. This five-year warranty does not cover products used for commercial, industrial or educational purposes. The warranty term for these claims will be limited to a two-year period.

This limited warranty does not apply to accessory items such as blades, drill bits, sanding discs, grinding wheels, belts, guide bearings and other related items.

Seller shall in no event be liable for death, injuries to persons or property, or for incidental, contingent, special, or consequential damages arising from the use of our products.

To take advantage of this warranty, proof of purchase documentation must be provided which has the date of purchase and an explanation of the complaint.

The Seller reserves the right to effect at any time, without prior notice, those alterations to parts, fittings, and accessory equipment which they may deem necessary for any reason whatsoever.

**To register your machine online, visit RIKON at [www.rikontools.com/warranty](http://www.rikontools.com/warranty)**

**To take advantage of this warranty, or if you have any questions,  
please contact us at 877-884-5167 or email [warranty@rikontools.com](mailto:warranty@rikontools.com)**



**For more information:  
16 Progress Road  
Billerica, MA 01821**

**877-884-5167 / 978-528-5380  
techsupport@rikontools.com  
parts@rikontools.com**



Link to RIKON website