

DEMOLITION TOOL

30 lb. class

KT-DT30



WHEN ORDERING REPLACEMENT PARTS, FURNISH THE MODEL NUMBER(S) AND SERIAL NUMBER (S) OF YOUR TOOLS.

Specifications 12

Net Weight	13.5 kg	30 lbs
Length	635 mm	25 in
Bore	40 mm	1.5625 in
Stroke	155 mm	6.0625 in
Blows per minute	800	800
Chuck Sizes	22 X 83 mm HEX	7/8 X 3 1/4" HEX
Air Inlet (NPT)	13 mm	1/2 in
Air Consumption*	1.2 m ³ /m	40 cfm

SCREW
ON
RETAINER

*estimated

WARNING:

ALWAYS DISCONNECT THE AIR SUPPLY BEFORE CHANGING CHISELS OR DISMANTLING THE TOOL FOR SERVICE OR REPAIR. FOR MAXIMUM SAFETY WE ADVISE THE INSTALLATION OF A SHUT-OFF VALVE AT THE END OF THE AIR LINE.

PARTS LIST DEMOLITION TOOL 30 lb. class KT-DT30

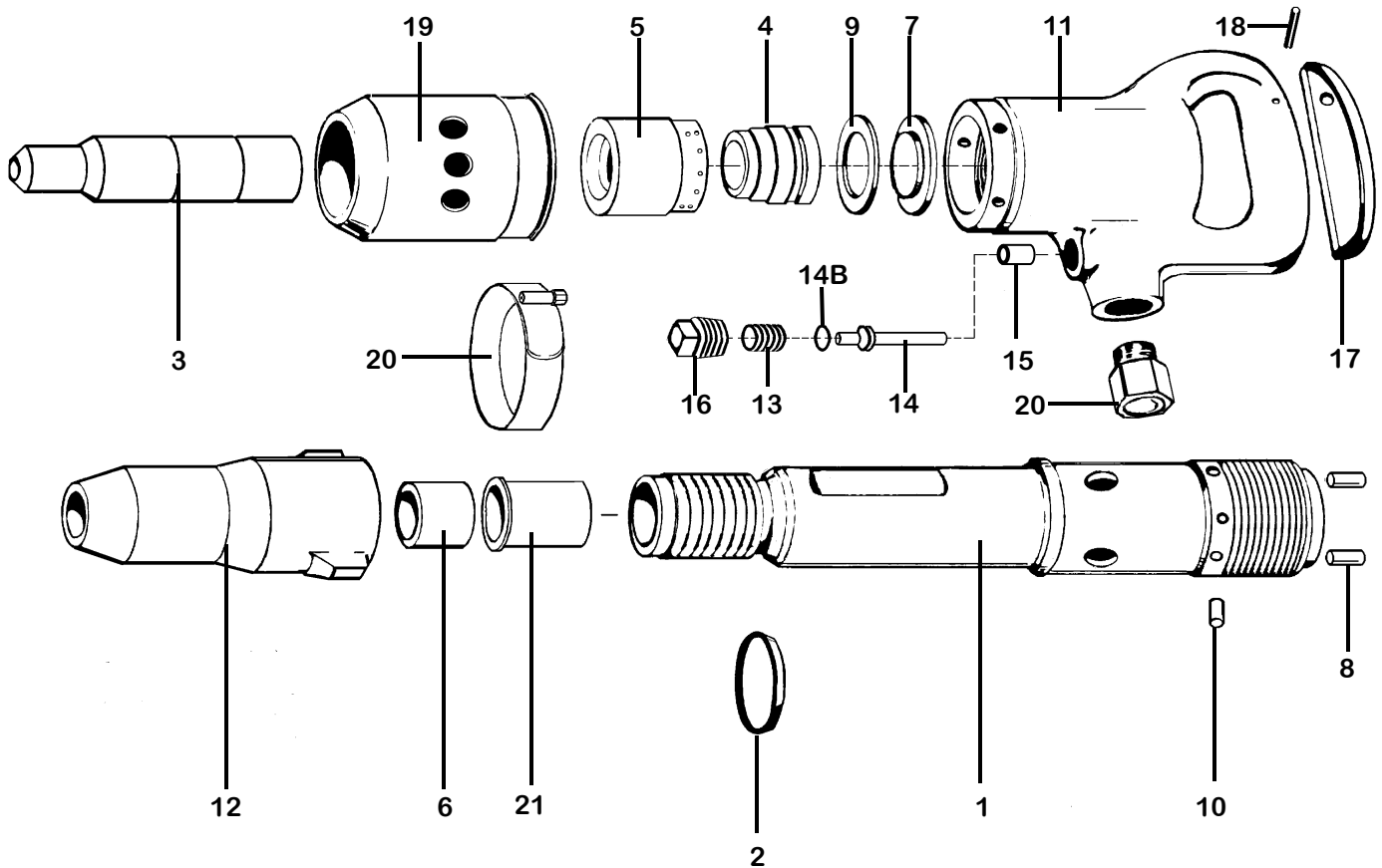

INDEX	PART	DESCRIPTION	INDEX	PART	DESCRIPTION
1	KT6461	CYLINDER	13	KT6133	THROTTLE VALVE SPRING
2	KT6462	WEAR RING	14	KT6474	THROTTLE VALVE
3	KT6463	PISTON	14B	KT6614B	THROTTLE VALVE O-RING
4	KT6464	AUTOMATIC VALVE	15	KT6475	THROTTLE VALVE BUSHING
5	KT6465	VALVE CHEST	16	KT6476	THROTTLE VALVE CAP
6	KT6466	BUMPER RING	17	KT6477	THROTTLE VALVE LEVER
7	KT6467	VALVE COVER PLATE	18	KT6478	THROTTLE LEVER PIN
8	KT6468	DOWEL PIN (2)	19	KT6479	EXHAUST CAP
9	KT6469	VALVE WEAR RING	20	KT6570	LOCK CLAMP
10	KT6470	LOCK KEY	21	KT6581	HEX BUSHING 7/8 X 3 1/4
11	KT6471	BACK HEAD BARE	22	KT6480N	HANDLE BUSHING, NPT
NS	KT6471C	BACK HEAD COMPLETE	NS	KT6235S	HOSE SWIVEL 3/4"NPT
12	KT6472	FRONTHEAD			