

PARTS LIST SCALER EXTENSION HANDLE

KT-XTH

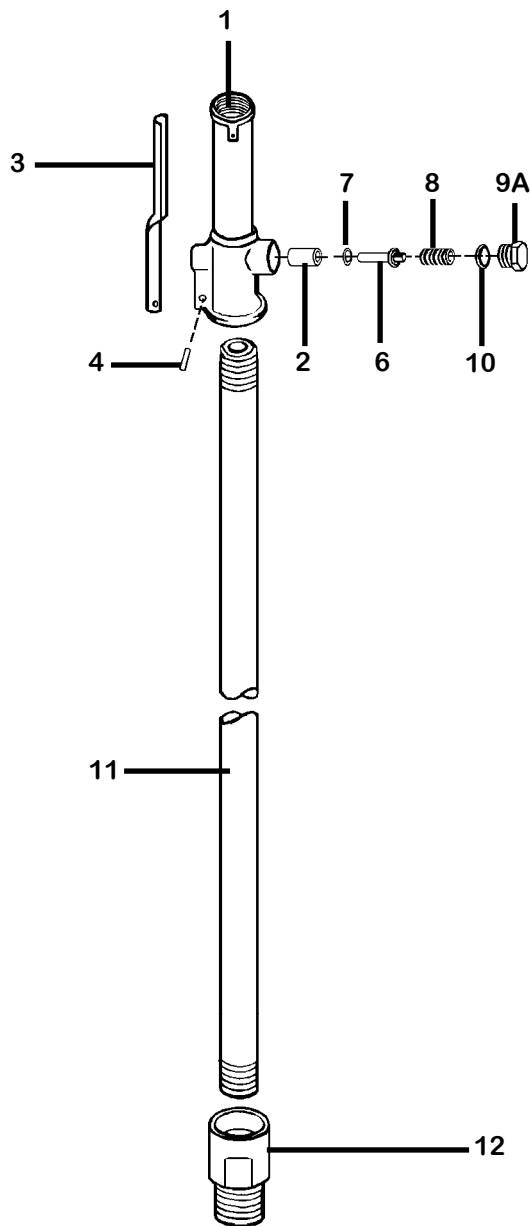

INDEX	PART	DESCRIPTION
NS	KT6500N	THROTTLE BODY COMPLETE
1	KT6501N	THROTTLE BODY BARE
2	KT6502	THROTTLE VALVE BUSHING
3	KT6503	THROTTLE LEVER
4	KT6504	THROTTLE LEVER FULCRUM PIN
6	KT6506	THROTTLE VALVE
7	KT6507	THROTTLE VALVE O-RING
8	KT6508	THROTTLE VALVE SPRING
9	KT6509A	THROTTLE VALVE PLUG
10	KT6510	THROTTLE VALVE PLUG O-RING
11	KT6178	CONNECTING PIPE 36"
12	KT5012S	CONNECTING PIPE NUT