

- Introduction

The new CFW3 series filter wheels are available in four sizes to accommodate filters from 1.25-inch to 50 millimeters square.

For filter wheel control a custom QHY 4-pin filter wheel port is included that provides power and control signals for QHY dual control filter wheels like the series 3 filter wheels. Both the series 2 and new series 3 filter wheels can be controlled by either an independent external program using the filter wheel's USB port or via the QHY 4-pin serial port. When connected to the QHY 4-pin port there is no need for an additional power cable or control program. All of the filter wheel functions are controlled through the camera and its operating Software.

The series 3 filter wheels utilize a new motor with direct drive and will reverse direction to take the shortest path when moving from one filter to another. For Example, in this demonstration the wheel moves from filter position 1 to position 2 to position 3 and then back to 1 again, over to position 7 and back to position 1 without ever making a complete rotation of the carousel. This saves time if you're doing a lot of filter changes in one imaging session.

LED changes color for each filter position. The tricolor LED assigns one unique color or combination of colors to each filter position so you can tell if it's moved to the correct position without removing it from the Telescope.

The CFW3 is also thin. This feature and the short back focus of the COLDMOS cameras means you can add one of several camera lens adapters for Canon and Nikon camera lenses for wide field imaging with the filter wheel.

In the center of the back plate is a 12-volt DC power port. This port is threaded for a short extension cable that is supplied with the camera that securely attaches such that it will not accidentally disconnect while you are imaging.

- Specifications

Model	Back Focus Consumed*	Filter Supported	Available height limitation (shall consider leaving the gap)	Weight	Reference Retail Price
CFW3XL	21.5mm	Slot1: 9 position 2inch mounted/ 50mm unmounted Slot2: 7 position 50mm*50mm square	10mm	1500g	USD1199
CFW3L	21.5mm	7 position 2inch mounted/50mm unmounted	10mm	911g	USD619
CFW3M-SR	20.5mm+2mm	5 position 2inch mounted/50mm unmounted	10mm	728g	USD349
CFW3M-US	17mm+2mm	7 position 36mm unmounted	5.5mm	691g	USD349
CFW3S-SR	20mm+4mm	7 position 1.25inch mounted/31mm unmounted	10mm	446g	USD279
CFW3S-US	15.5mm+4mm	7 position 1.25inch mounted/31mm unmounted	5.5mm	419g	USD279

*Back Focus Consumed

For the convenience of calculation, all the data displayed are the increase in the back focal length taken up by using the adapter, which is not necessarily equal to the thickness of the component itself. All the adapter data provided by QHYCCD are based on the focal length increment. For More information please see: [Adapter Kits 2.0 \(ComboA1~E1\)](#)

The Calculation of Filter Wheel's back focus consumed includes two parts: The thickness of the filter wheel body (like the 15.5mm of CFW3S-US), and the back focus consumed (like 4mm of CFW3S-US).

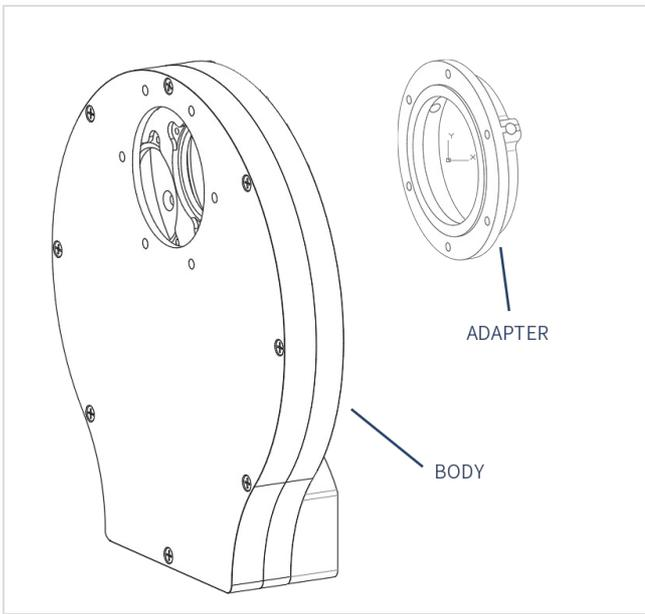

We list BFL consumed data of both CFW body and adapter at our Adapter System 2.0 instructions (like kit A1, see below). When you use some kits of Adapter System 2.0, you may need to remove this filter wheel adapter. (like kit A2, see below).

QHYCCD

	M48 Output	OAGM			CFW3M(US)&Adapter	
55mm =	5mm	10mm	3mm	0.5mm	17mm+2mm	17.5mm

COMBO A1

QHY163M/294M

For MPCC (M48, BFL=55mm)

Note: Put OAG at the position next to the M48 Output to make both main cam and guiding cam focused.

Or

[22mm M3 Screws*6 to fix adapters]

(If OAG is not used)

QHYCCD

	Canon Adapter				CFW3M(US)+ Cam (Default Adapter Removed)
44.1mm =	10mm	4mm	3mm	1mm	26mm Total

COMBO A2

QHY294M/163M

For Canon EF Lens (BFL=44.1mm)

[10mm M3 Screws*6 to fix adapters]

New Adapter Added

Removed From CFW

Removed From Cam

- Mechanical Dimensions

QHYCFW3-S-SR

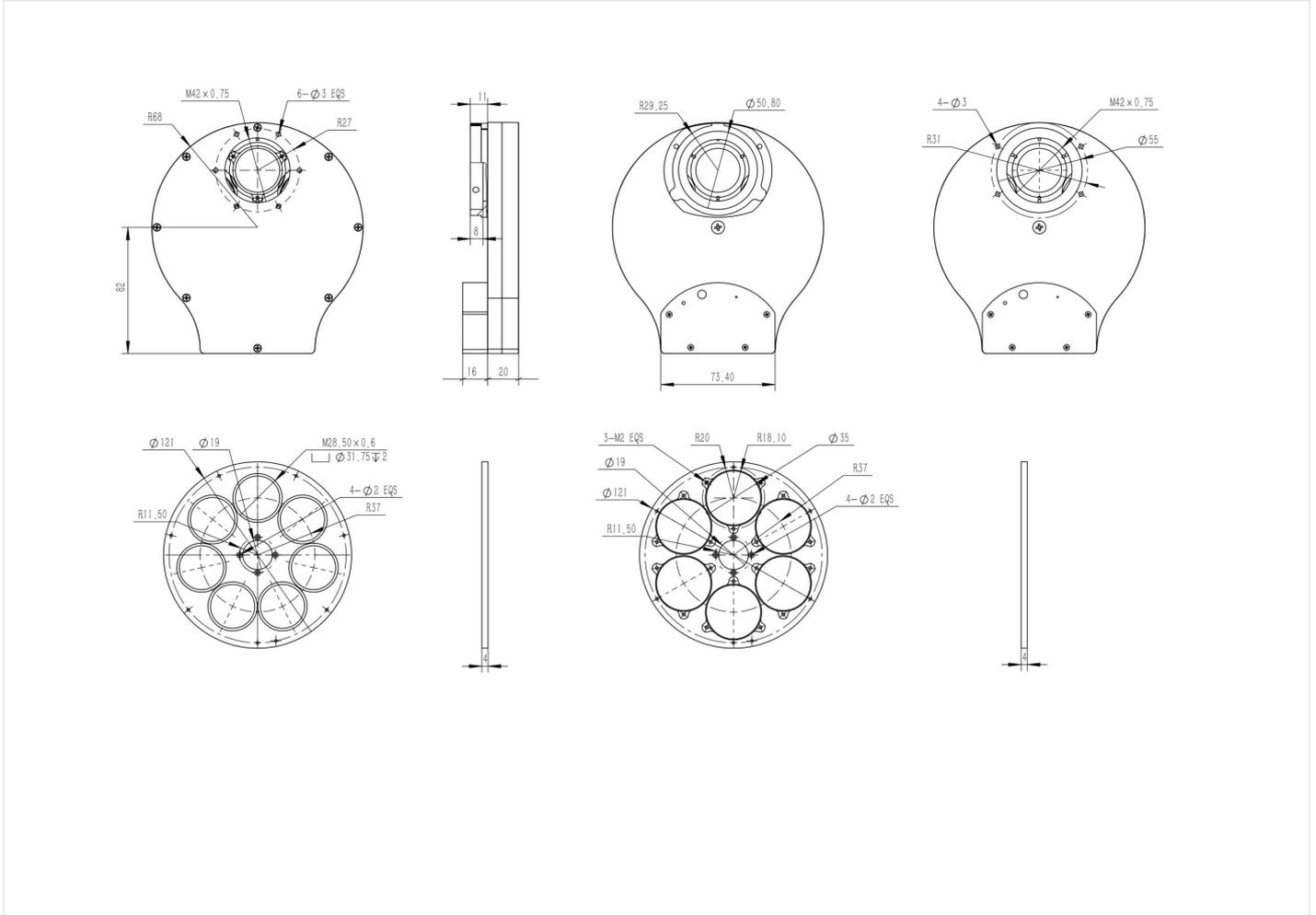

QHYCFW3-S-US

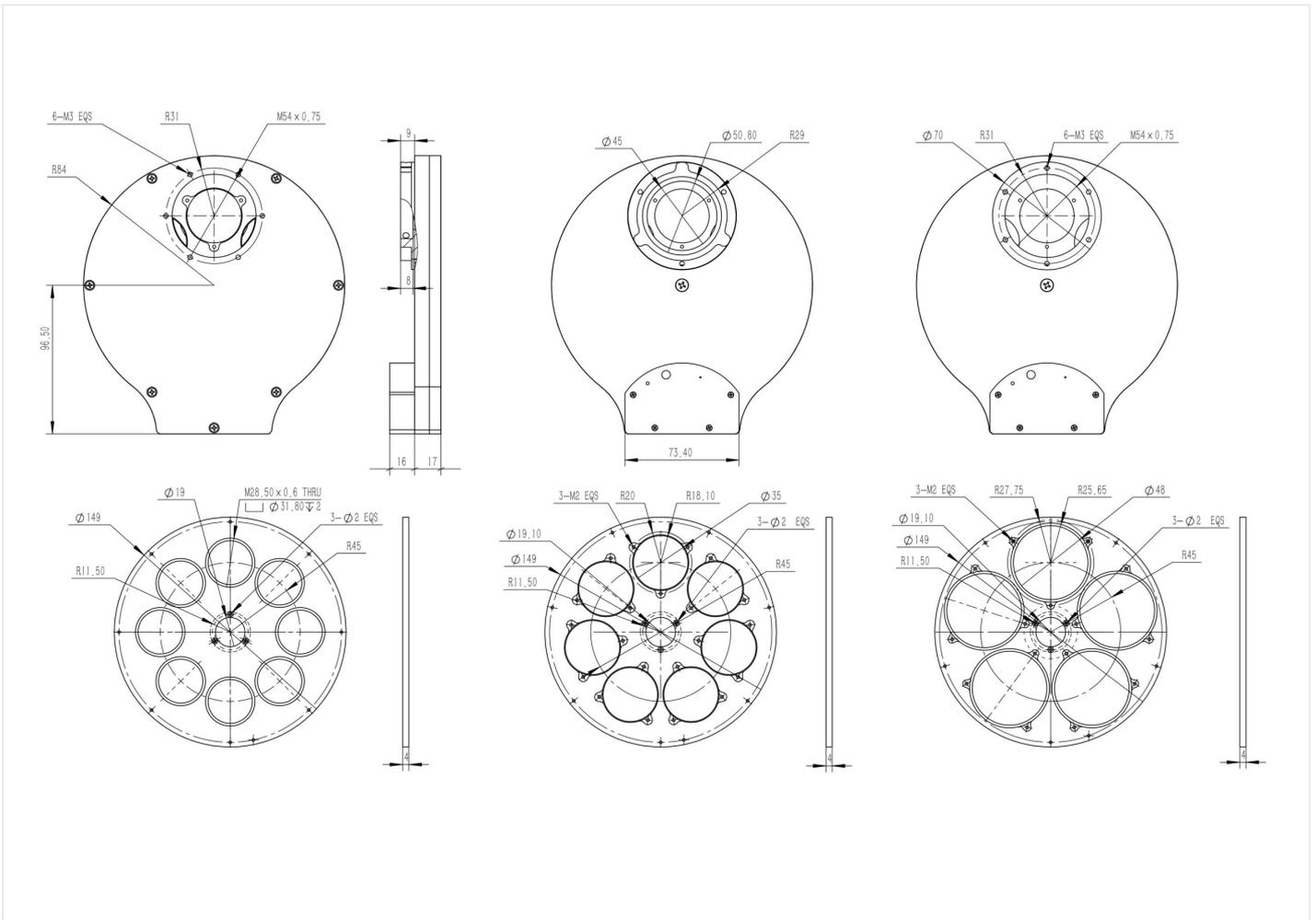

QHYCFW3-M-SR

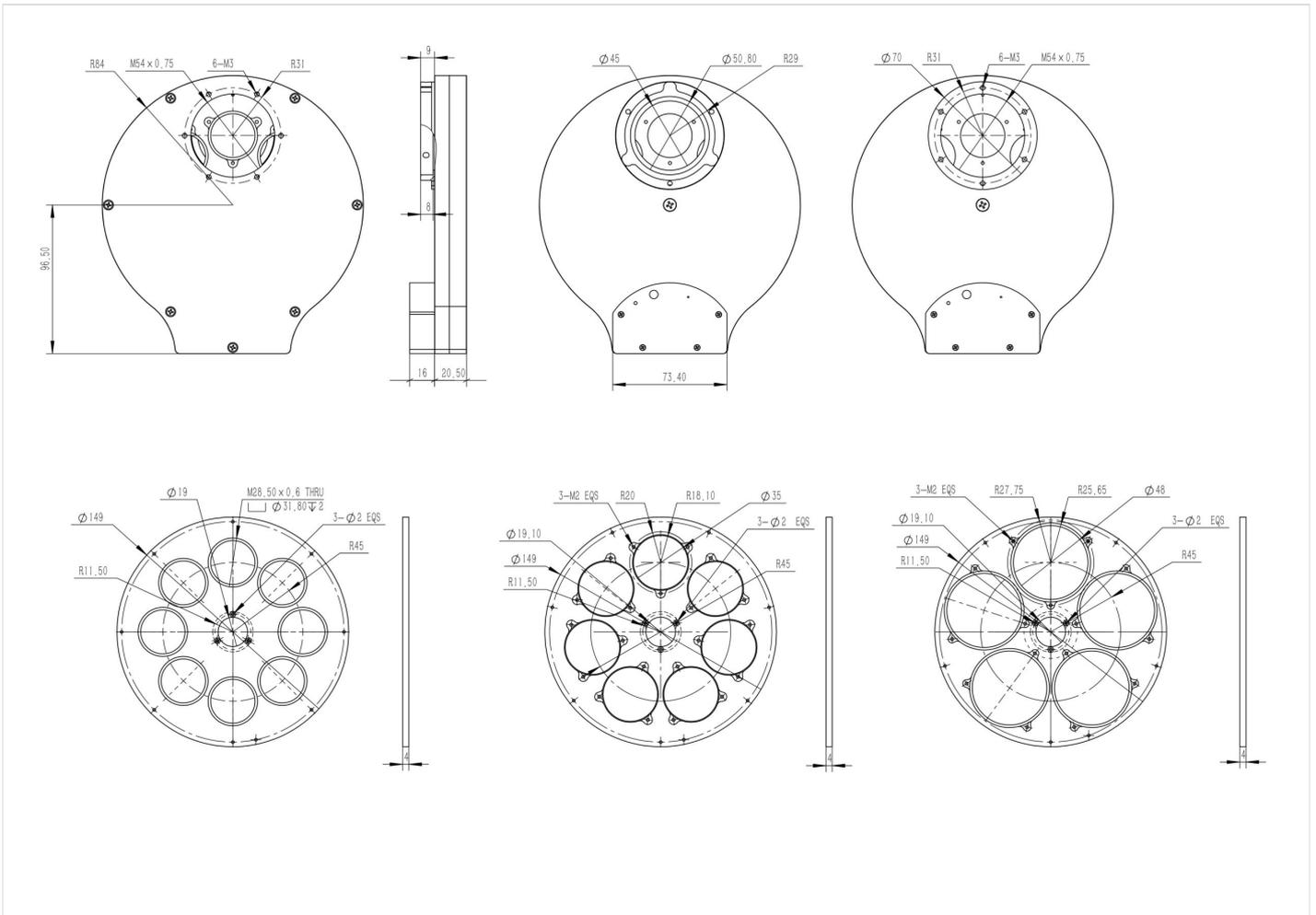

QHYCFW3-M-US

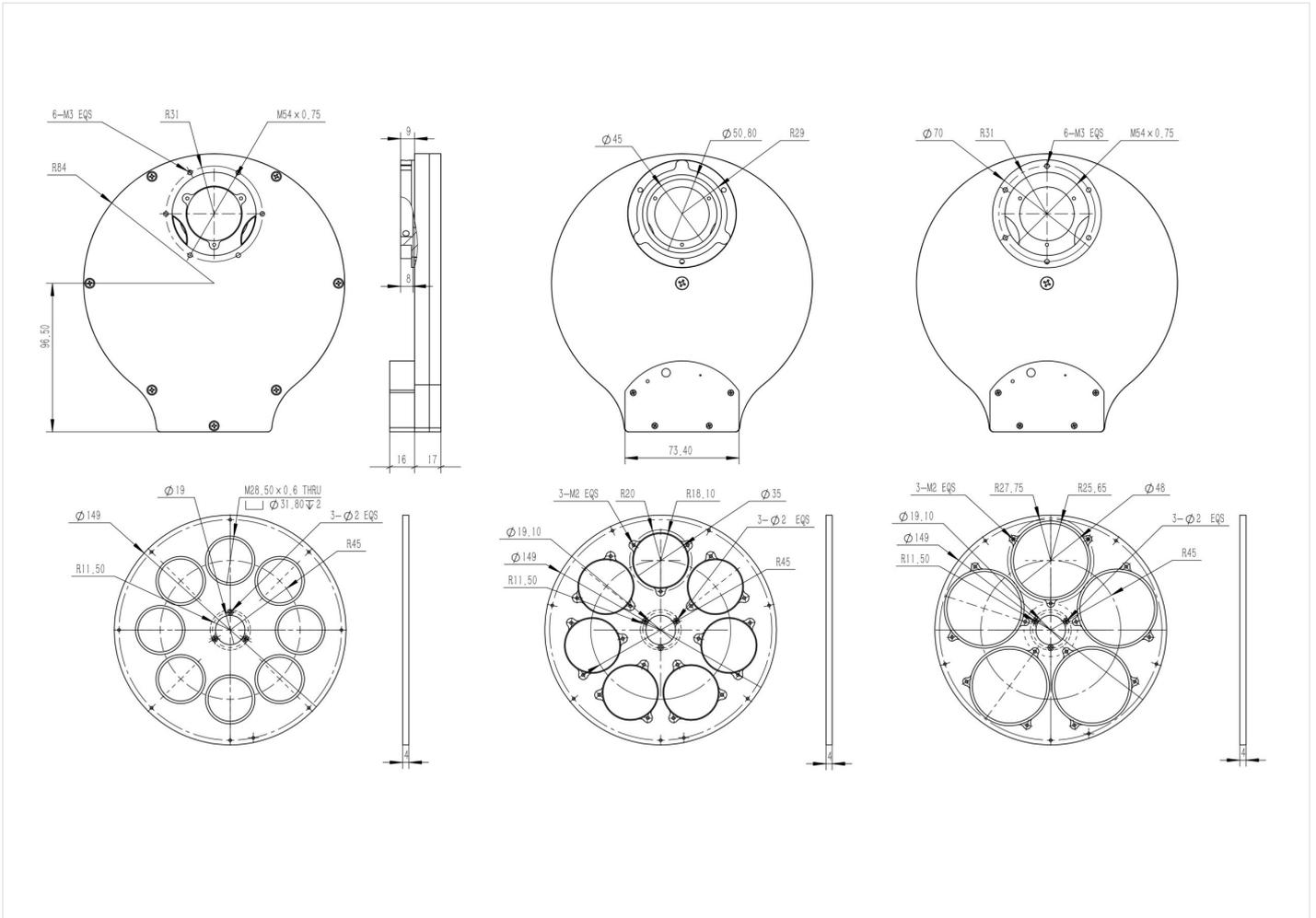

QHYCFW3-L

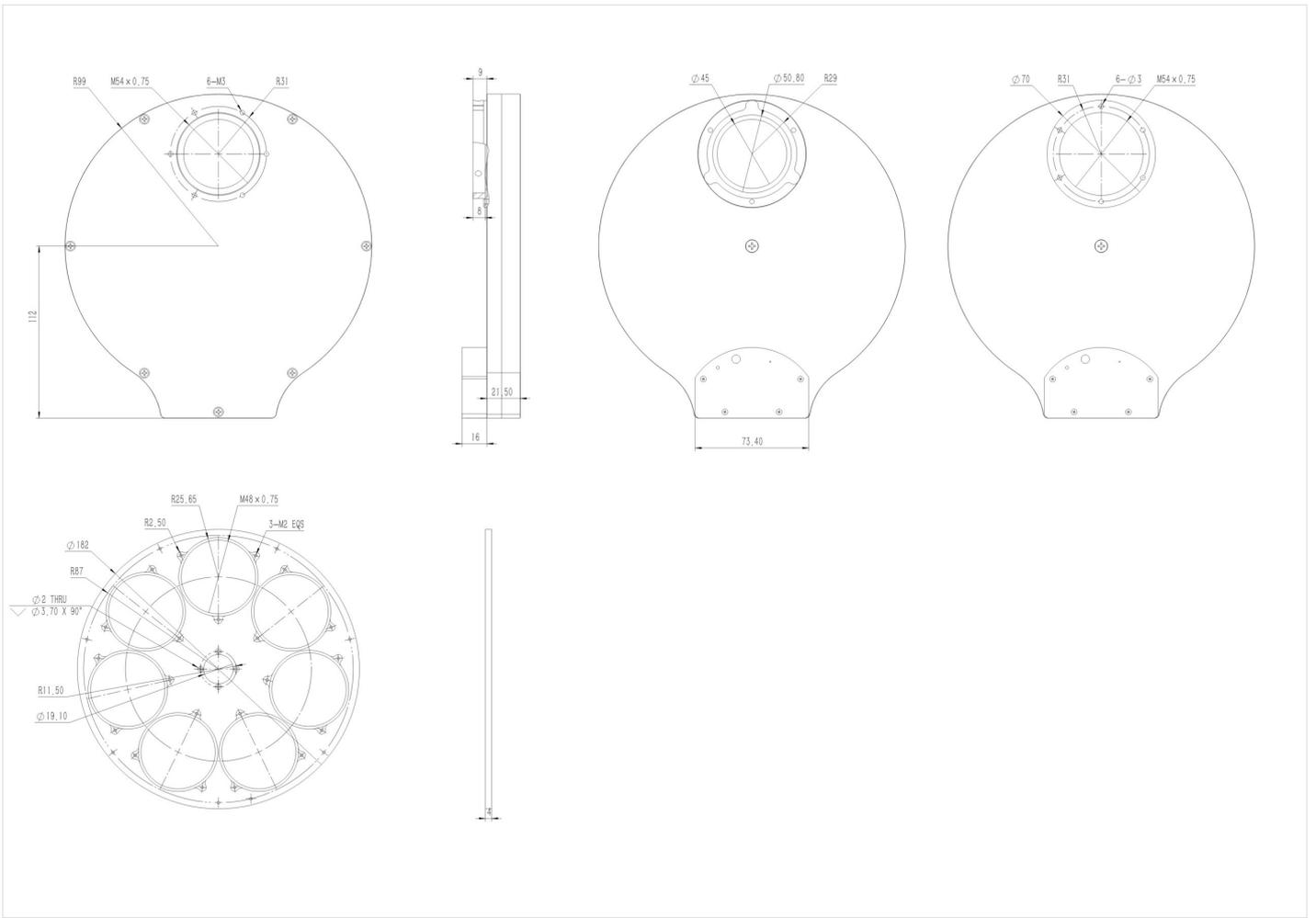

QHCFW3-XL

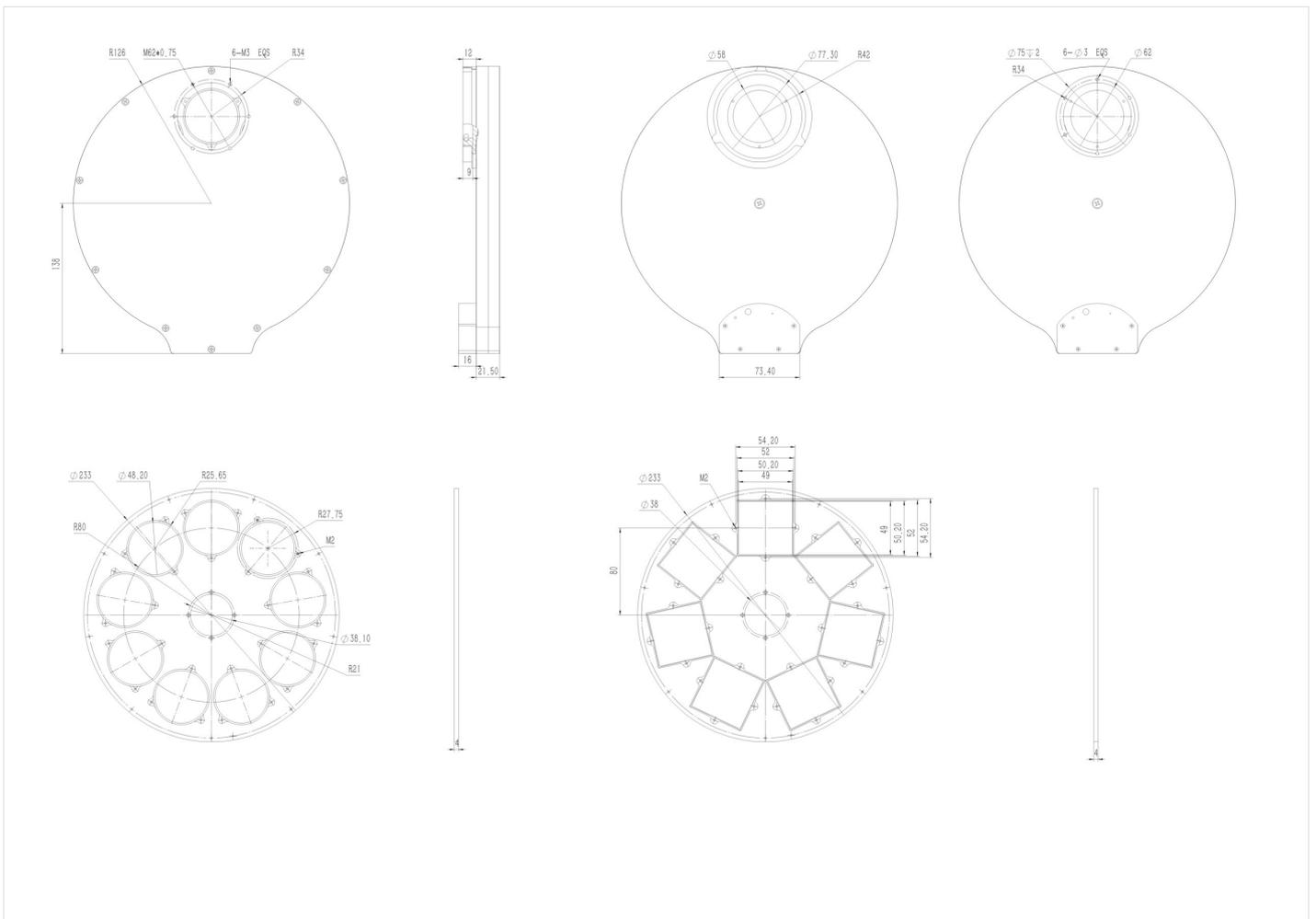

- User Guide

- 1. Safety instructions and precautions

Safety instructions

1. Do not insert your fingers into the round holes on the filter wheel, otherwise the filter disc may cause finger injury.
2. The copper nails in the filter wheel cannot be disassembled, otherwise the filter wheel will loosen and affect normal use.
3. When the camera uses the control line to control the filter wheel, it is forbidden to use the USB cable to connect the filter wheel at the same time to prevent the power supply from damaging the filter wheel.
4. For the frameless filter, when using the screw to press the lens, it must be pressed by the plastic gasket, but not directly with the metal nut of the screw. Otherwise there is a risk of crushing the lens.

Precautions:1. Open the package, check the product, check whether the accessories are complete, and check the "Filter Wheel QHYCFW3 Accessories Table"

2. Before installation, you need to prepare the tools needed to install the filter wheel: tweezers, medium cross screwdriver, clock screwdriver.
3. After the installation is complete, please use the software to control the color wheel rotation to see if the rotation is smooth and whether every position can come. Whether there is a serious card in the middle (if there is a slight card in the middle, it will not affect the use, the color wheel will continue to rotate until it reaches the target).
4. Do not push hard when installing the filter wheel. Failure to do so may result in bearing crushage and other malfunctions or damage. **Important Notes:**QHYCFW3 support two socket mode. One is the 4PIN QHYCFW socket. If your QHYCCD camera has the 4PIN socket you can connect it directly with QHYCFW3. There is the 12V power in the 4PIN socket . So it does not need any extra power supply. If you have no QHYCCD camera or the camera has no 4PIN QHYCFW socket. You can use the USB socket to connect with the computer. And the QHYCFW3 can be powered and controlled with USB port. Please note the current requirement when using the USB cable is higher (780mA) than the USB2.0 port can supply and some computer will limit the current to 500mA. In this condition, QHYCFW3 can draw the power from the QHYCFW socket port (the 6PIN RJ11 port in the QHYCFW3) and you need a 12V to RJ11 cable to power the QHYCFW2. When using this method. The current drawing from USB cable will reduce to less than 100mA when motor rotating. (* The 12V to RJ11 cable is in the standard item list after 2019.4).

- 1.2 Interface and accessory



1. Control port switching button: This button is used to set the interface mode. There is two mode: USB control mode and 4PIN control mode. If you use the USB cable to control QHYCFW3 you need to select the USB control mode. If you use the 4pin QHYCFW socket cable to control the QHYCFW3 from QHYCCD camera, you need to select the 4PIN control mode. This switch button is inside the case. You can push it on and off. But since it is inside the case, you can not know which position it is. So QHYCFW3 has a LED indicator to tell you of it. When the filter wheel is powered on , if the indicator light flashing for one second and it is red color, the filter wheel is in the USB control mode; if green color the filter wheel is in the 4PIN control mode.

2. Status indicator: Each filter wheel hole position corresponds to a specific color. And this indicator will display if the CFW3 working in the USB control mode or the 4pin control mode. When power on the QHYCFW3, it will be on for one second then off. If it is red color, the QHYCFW3 is in USB control mode. If it is green, the QHYCFW3 is in 4pin mode. the indicator light is off to prevent shooting light pollution the indicator light is off to prevent shooting light pollution.

3. Reset button: After pressing, the filter wheel hardware is reset, the turntable returns to the initial position, the default hole 1

Filter wheel standard accessories

1. Filter wheel body
2. 2-inch extension tube
3. M4 metal hand screws
4. Filter fixing nails, including gasket
5. Filter wheel connected to camera control line

- 1.3 Fix filters and match the camera

Match CFW3 and Camera



First remove all the screws outside .

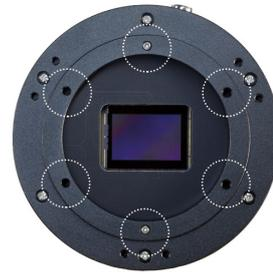

There are several ways to connect CFW3 and cams. For example, 294M and 600M can be directly connected with default adapters, while 268M needs to be connected by 4 to 6 screws and the filter wheel adapter needs to be removed. Default CFW adapter also needs to be removed when you want to get shorter back focal length.

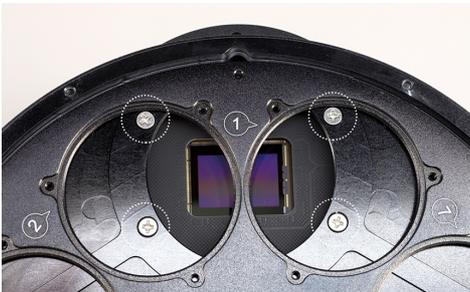

We recommend you only fix these four screws when the cam is not heavy, like 294M and 268M. That is firm enough and no need to remove the filter holder when you want to separate them .

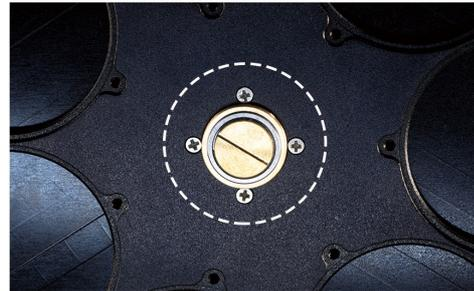

If you need to remove the filter wheel adapters, please disassemble these four small screws in the center of the filter holder first (**Do Not Remove The Center AXIS!**).

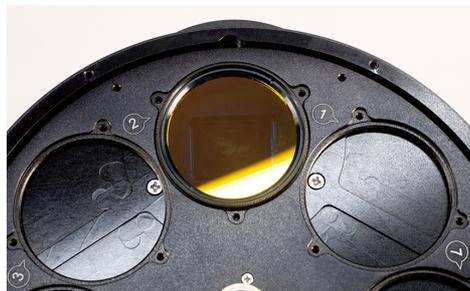

Then fix the filters you have and install the removed part back. It' s done!

www.qhyccd.com

- 2.1 Filter wheel control with ASCOM

Take MDL as example. First make sure you have installed the MaxIm DL, the filter wheel driver, the camera driver,

the ASCOM driver for the filter wheel [ASCOM Driver 4PIN](#) and the ASCOM driver for the camera. Then, connect the filter wheel and camera with 4pin wires in sequence (except for the special trigger cable except QHY9), connect the camera and computer with USB cable, and connect a 12V power supply to power the camera. After the correct connection, the third generation filter wheel will automatically rotate two turns and then rest. Open MaxIm DL, take QHY178 as an example, click on Camera Control (the icon with a box in the picture).

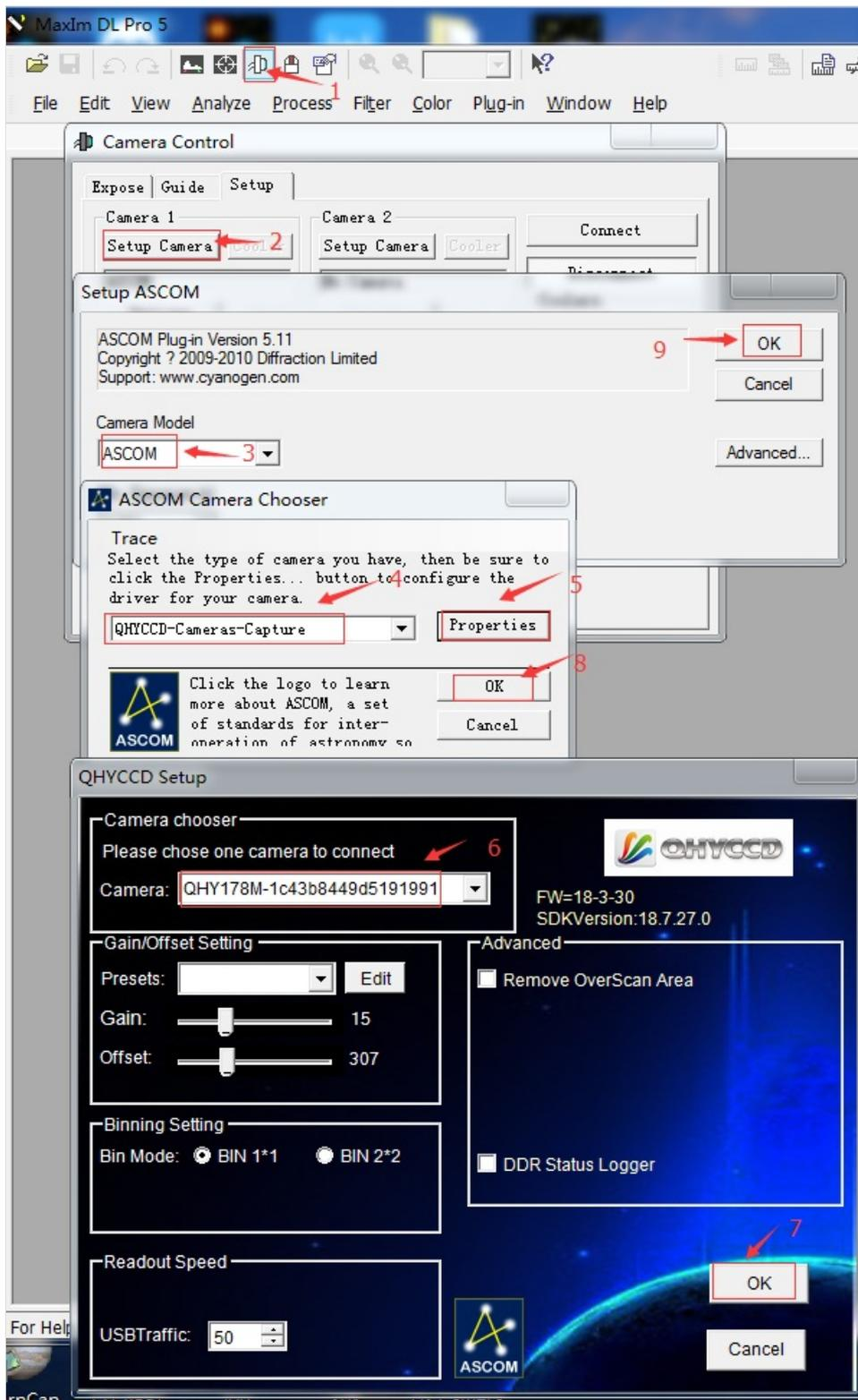

After connecting the camera, go back to the interface and select Setup Filter to select the filter wheel. Follow the steps (as shown).

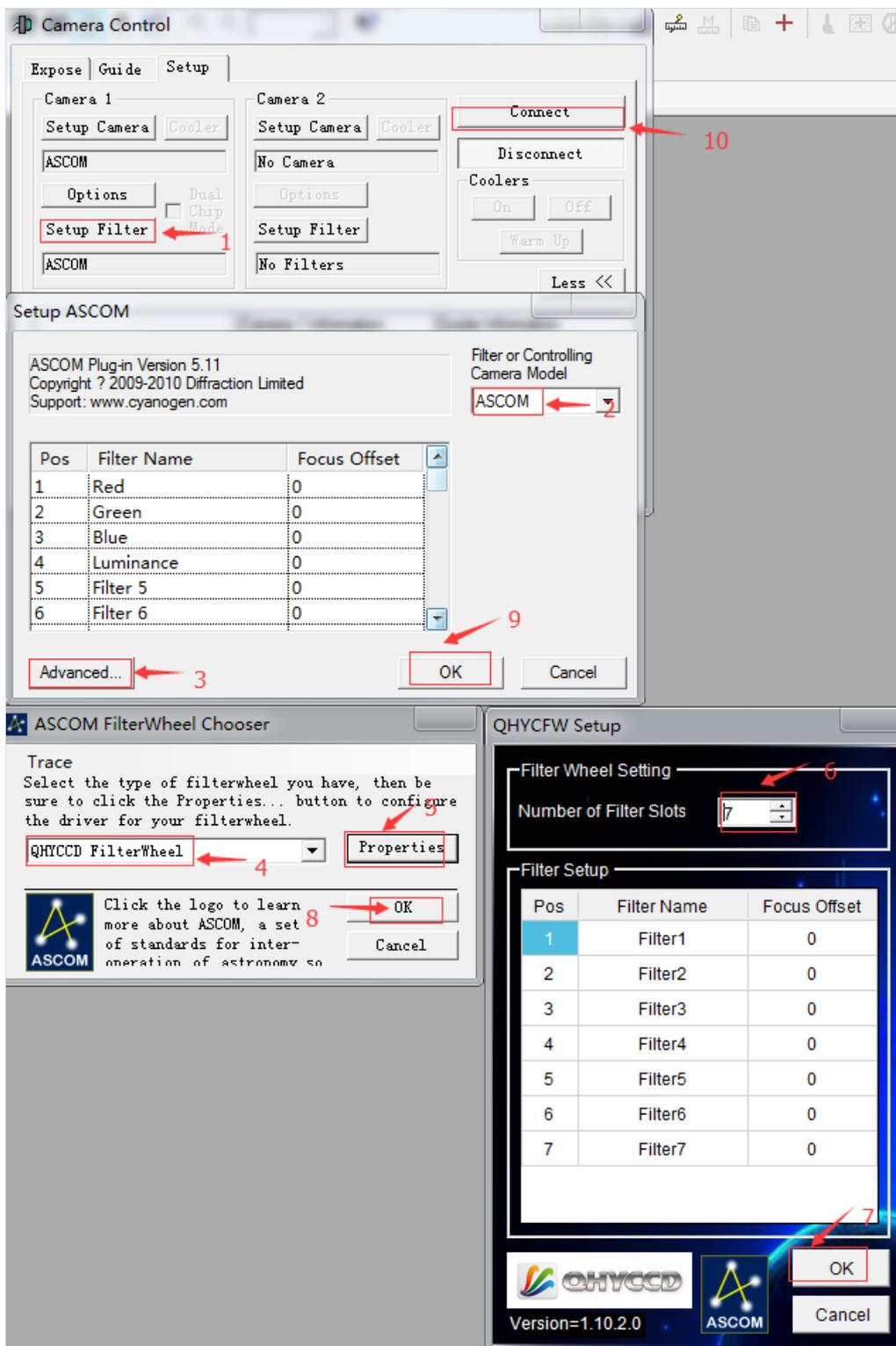

Select the appropriate hole position to operate.

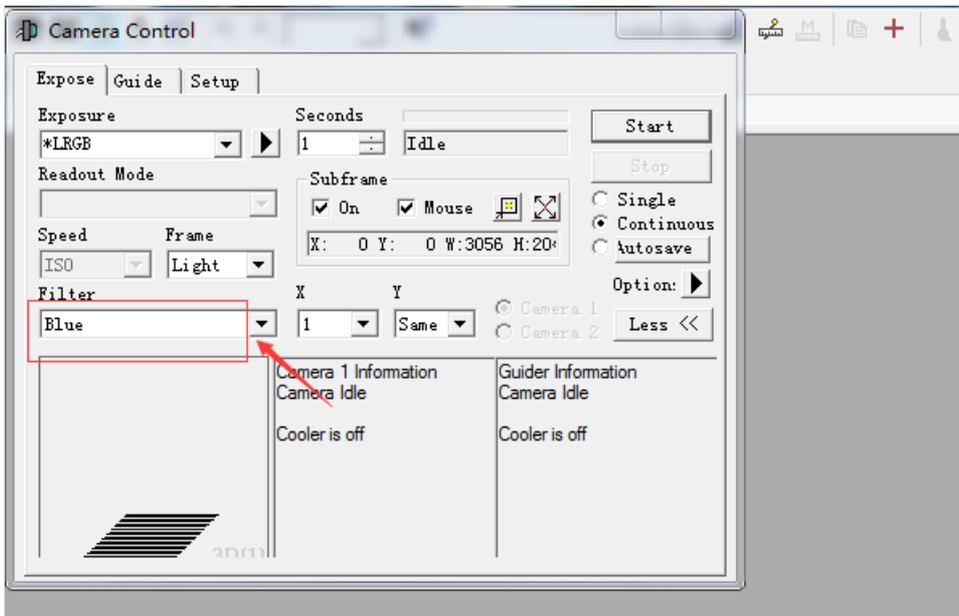

- 2.2 Use USB cable to control the filter wheel

This method is implemented by ASCOM, which requires only a USB cable to control the filter wheel without connecting the camera. First, we need to switch the control port button (shown by the red arrow in the figure below) to implement USB port control. (Observation indicator red light indicates USB control mode)



Use the USB cable to plug into the USB port of the filter wheel and the other end to connect to the computer.

Open the device manager to check the port number (if the driver is installed on the computer, the driver to be installed will be detected automatically, otherwise the [2CP210X](#) driver will need to be installed).

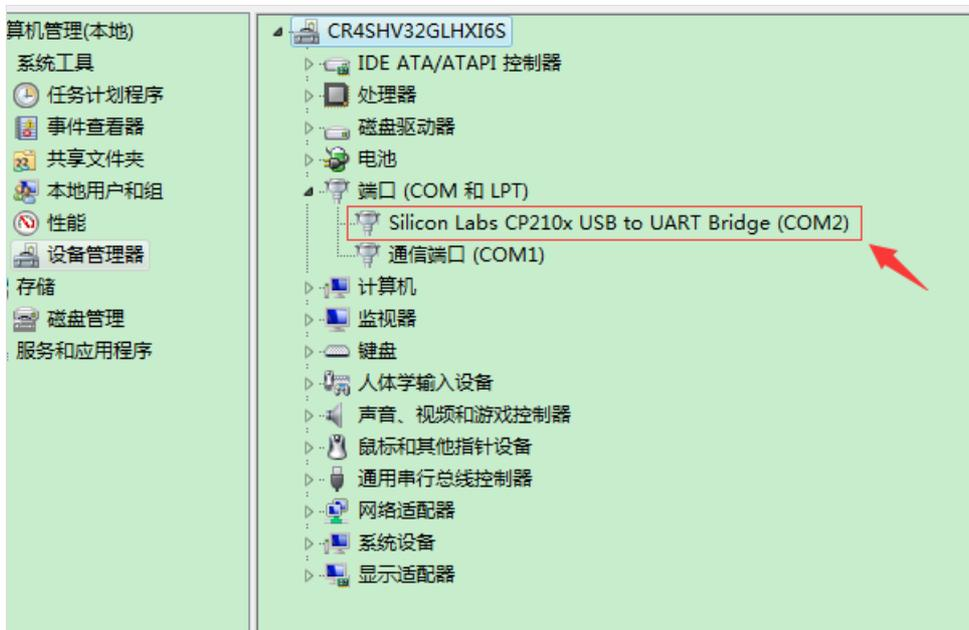

Open the MaxIm DL software and click on Camera Control. As shown

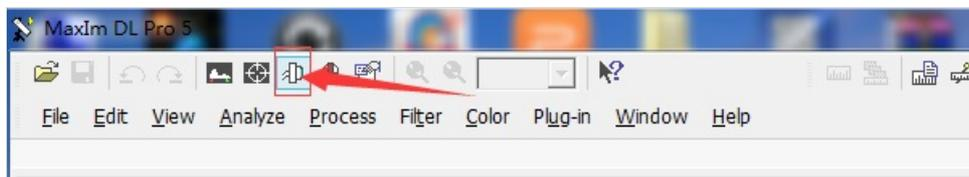

Popup page

Click on Setup and then click on the Camera model drop-down menu in the Setup Camera to select the ASCOM option. Then click the “Advanced” button on the right to bring up a new window for ASCOM Camera Chooser, and then select a virtual camera model from the drop-down menu. This will ensure that the software runs in an orderly manner. As shown below:

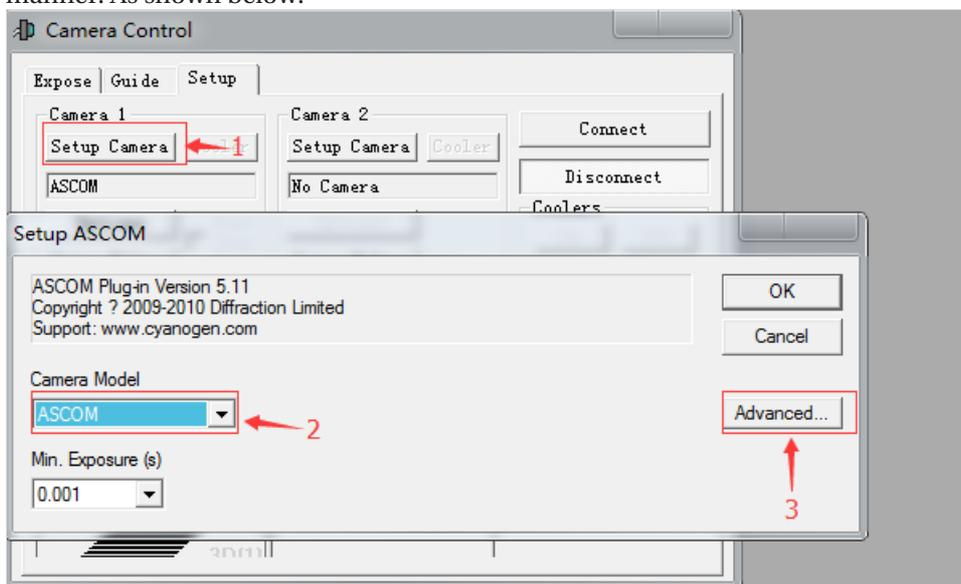

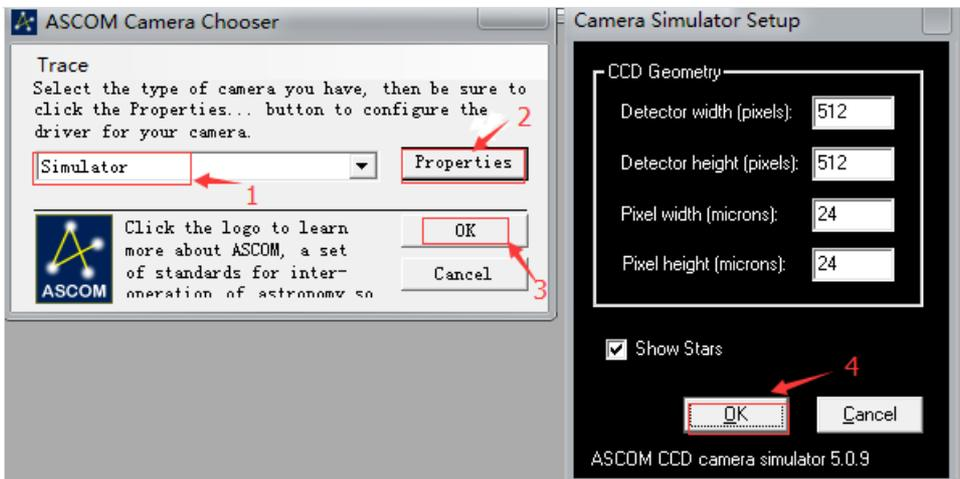

After confirming the error, click the ok button continuously. Go back to the Camera Control page.

Click the Setup Filter button below the Camera Control page to bring up

First click on the drop-down menu of Filter or controlling camera model in the upper right corner to select ASCOM. Click on Advanced in the lower left corner. A new ASCOM Filterwheel Chooser window pops up. Select the connected filter wheel in the strip box.

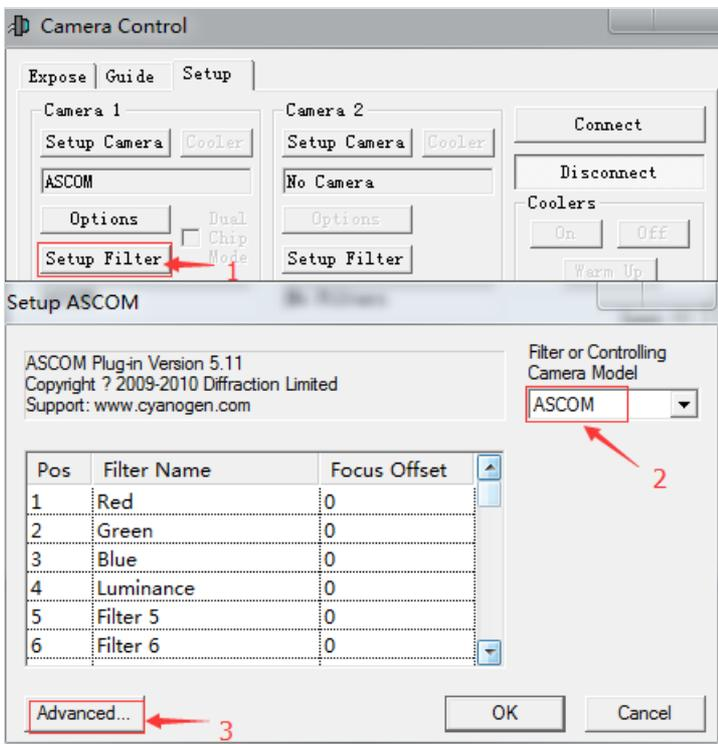

A new ASCOM Filterwheel Chooser window pops up. Select the connected filter wheel in the strip box.

Click on Properties to determine the filter wheel properties. Make sure to select the port that matches the previous download driver, click ok to return to the Camera Control page.

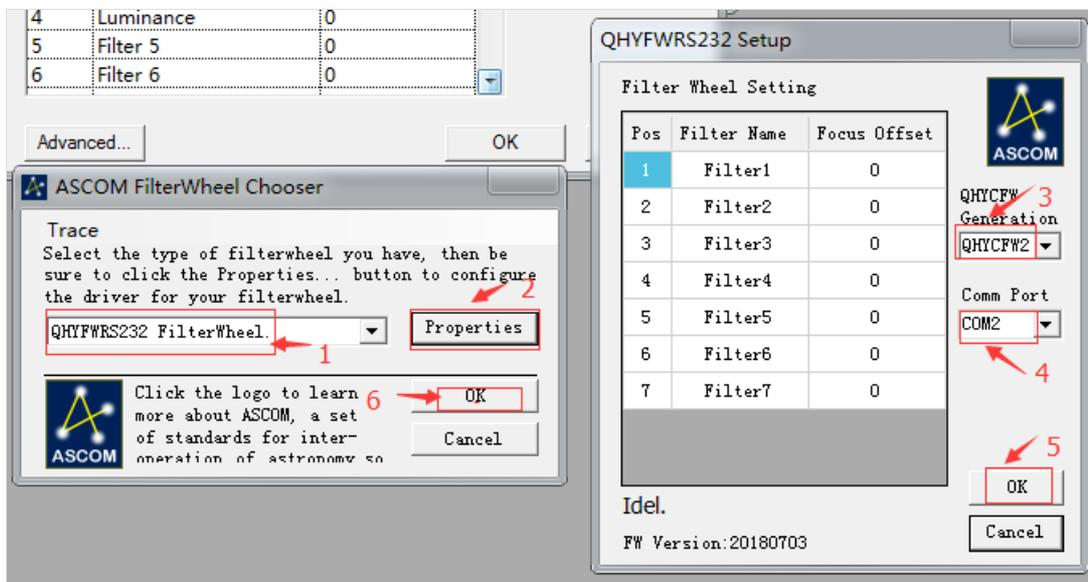

After returning to the Camera Control page, click the connect link in the top right corner. Finally, switch to the Expose page, click the Filter button in the lower left corner, select the options in the drop-down menu, select the option, the filter wheel rotates, and the operation is successful.

