

# Super II™

high precision counting  
and weighing scale

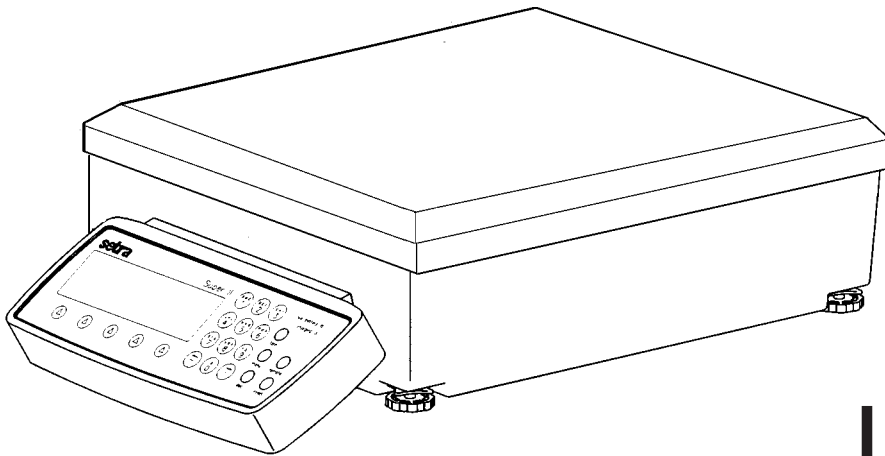

## Advantages to Consider

- Backlit Display (optional)
- Paperless inventory with onboard database
- Checkweighing using set-points
- Sturdy, all metal construction for long life
- Graphic LCD to provide easily customized messages
- Macros offering simplified one-key operation
- Comm ports for simultaneous connection to a printer, a scanner, and a PC
- Speedy transaction processing and data logging
- Effortless keyboard data entry - optional QWERTY keyboard
- Portable operation - optional internal battery
- Multiple bases operated by one controller - remote scale option
- English & bar coded labels - optional Dymo Setra 300 printer

The Setra *Super II* combines incredible accuracy with easy-to-read, text prompts. With an internal database, bar code label making, set points and multiple base connectivity, the *Super II* is truly flexible. Input to the database can be entered with most computer keyboards or from the user friendly, cell phone style keypad. The scale menu that orders up a wide selection of features is easy to access, easy to navigate and easy to exit. Use it to build a log of daily transactions, customize display prompts, or set the optimal sample size for counting. Multiple ports keep you constantly connected...to a scanner, to a printer, to a computer, to your bulk weighing scale and to up to eight bases. *Super II* is unquestionably the superior choice in count-ing scales for all your receiving, kitting and inventory needs.

CAPACITY	STANDARD READABILITY	MAXIMUM READABILITY	LINEARITY ERROR
2 Kg	0.00002 Kg	0.000002 Kg	+/-0.00002 Kg
5 Kg	0.00005 Kg	0.000005 Kg	+/-0.00005 Kg
12 Kg	0.0002 Kg	0.00002 Kg	+/- 0.0002 Kg
16Kg	0.0002 Kg	0.00002 Kg	+/- 0.0002 Kg
25 Kg	0.0005 Kg	0.00005 Kg	+/- 0.0005 Kg
30 Kg	0.0005 Kg	0.00005 Kg	+/- 0.0005 Kg
50 Kg	0.001 Kg	0.0001 Kg	+/- 0.001 Kg
4.4 lb	0.00005 lb	0.000005 lb	+/-0.00005 lb
11 lb	0.0002 lb	0.00002 lb	+/-0.0002 lb
27 lb	0.0005 lb	0.00005 lb	+/-0.0005 lb
35 lb	0.0005 lb	0.00005 lb	+/-0.0005 lb
55 lb	0.001 lb	0.0001 lb	+/- 0.001 lb
65 lb	0.001 lb	0.0001 lb	+/- 0.001 lb
110 lb	0.002 lb	0.0002 lb	+/- 0.002 lb

**setra**

159 Swanson Road, Boxborough, MA 01719  
978 263-1400 • fax 978 635-9551 • www.setra.com

# Super II™ Specifications

**Displayed Resolution:** Selectable

**Internal Resolution:** 1 part in 1,000,000

**Units of Measure:** Pounds, kilograms, grams, ounces, pennyweights, troy ounces, carats, grains (user definable)

**Display Update Rate:** Selectable, five settings

**Response Time:** Two seconds (typical)

**Counting Capacity:** 10,000,000 pieces

**Memory:** 750 records including part number (23 characters), description (16 characters), count, average piece weight, tare, set points

**Time and Date:** Battery protected real time clock

**Data Communications:** Bi-Directional RS232 port for PC; OUT port for printer; IN port for scanner, KEYBOARD port for QWERTY PS/2® (6 pin mini DIN) style PC keyboard

**Selectable Baud Rate:** 1200, 2400, 4800, 9600 (Com 1, 2, and 3)

**Operating Temperatures:** 40 °F to 100 °F (5 °C to 39 °C) 10 to 90% non-condensing

**Power Adapters :** Output 16VDC @ 550 mA, Input 120 VAC, 60 Hz or 230 VAC, 50 Hz

**Dimensions:**

**25 - 50 Kg**

Platform 13" W x 15" D (33 x 38 cm)  
 Controller 10.75" W x 4.38" D x 2.5" H (27 x 11 x 6 cm)  
 Overall 13" W x 19.38" x 4.5" H (33 x 48 11.5 cm)

**12 - 16 Kg**

Platform 11.5" W x 9.5" D (29 x 24 cm)  
 Controller 10.75" W x 4.38" D x 2.5" H (27 x 11 x 6 cm)  
 Overall 11.5" W x 14" D" x 4.75" H (29 x 35 12 cm)

**2 - 5 Kg**

Platform 6.2" Diameter  
 Controller 10.75" W x 4.38" D x 2.5" H (27 x 11 x 6 cm)  
 Overall 11.5" W x 14" D" x 4.75" H (29 x 35 12 cm)

**Shipping Weight:** 35.5 lb (16 Kg)  
 20 lb ( 9 Kg)  
 16 lb (7.25 Kg)

**Certifications:** UL, CSA, CE, ISO 9001

**Limited Warranty:** Two years

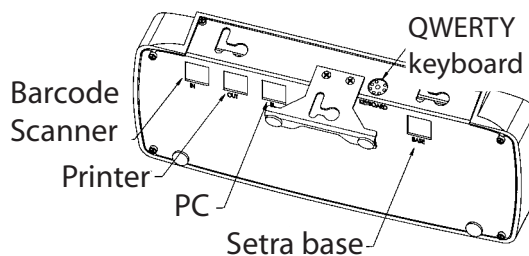
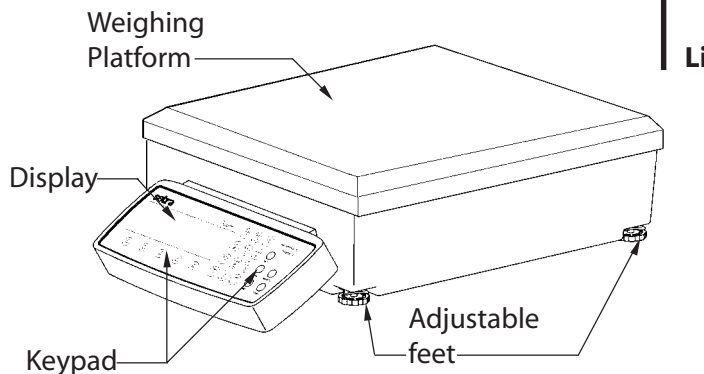

**Controller Ports**

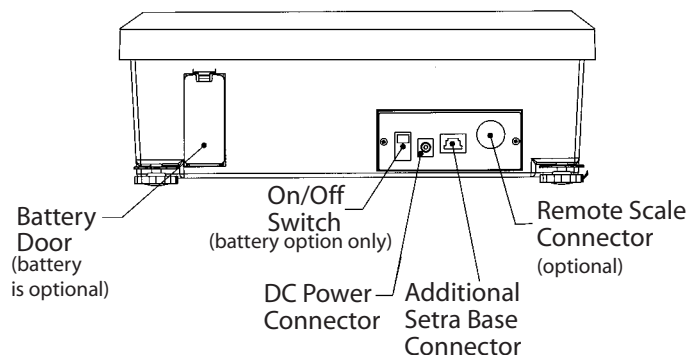

**Setra Base - Rear View**

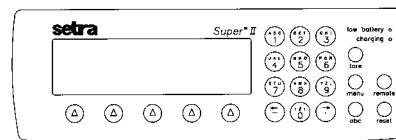

**Keypad**



159 Swanson Road, Boxborough, MA 01719  
 978 263-1400 • fax 978 635-9551 • www.setra.com