

**Description**

Series BD servovalves provide high resolution in the control of position, velocity and force in motion control applications.

**Features**

- Rugged reliable trouble-free operation.
- Reduced contaminant sensitivity.
- Linear flow gain characteristics.
- Intrinsically safe model available.
- Explosion proof model available.

**Operation**

When used in conjunction with Series BD90/95 and BD101 servo amplifiers or a motion controller, Series BD valves will provide accurate control of rotary and linear actuators.

**Specifications**

Rated Flow @ 1000 PSI ΔP	3.78–151 LPM (1.0 – 40 GPM)	
Linearity	≤ 5%	
Hysteresis	≤ 3%	
Threshold	≤ 0.5%	
Fluid	Mineral oil, 60–225 SSU, max. 1000 SSU	
Oper. Temp. (Ambient)	–1 to 106°C (30 to +225°F)	
Pressure Gain	3% of spool shift	
Null Shift with Temperature	< ± 2% per 38°C (100°F)	
Null Shift with Supply Pressure	< 2% per 69 Bar (1000 PSI)	
Quiescent Flow (Std. Spool Lap)	BD15 – 1.5–2.1 LPM (.40–.55 GPM)	BD30 – 2.1–3.78 LPM (.55 – 1.0 GPM)
Step Response Input	Model	Typical Step Response Input
	BD15	10 to 90%, 26 ms
	BD30	10 to 90%, 30 ms
<b>Pressure Ranges</b>		
For optimum performance, Parker Servo Valves are designed to operate within specific system supply pressure ranges.		
<u>System Supply Pressure</u>		
180–210 Bar (2600–3000 PSI)	48–66 Bar (700–950 PSI)	
138–172 Bar (2000–2500 PSI)	14–45 Bar (200–650 PSI)	
95–133 Bar (1400–1950 PSI)	0–210 Bar (0–3000 PSI)	
68–90 Bar (1000–1300 PSI)	External Pilot	
Filtration	SAE Class 3 or better, ISO Code 17/15/12	
Protection Class	NEMA 1 (IP54)	

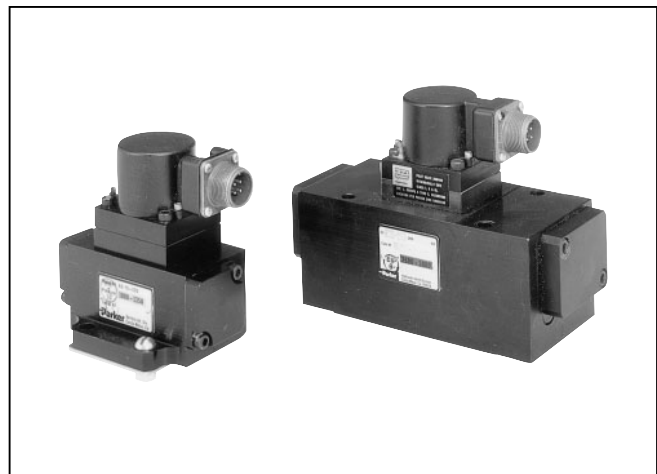

**Flow–Load Characteristics**

Control flow to the load will change with load pressure and valve current as shown in figure 1. These characteristics closely follow the theoretical square–root relationship for sharp–edged orifices as illustrated in the equation below.

$$Q = K\sqrt{\Delta P}$$

- Q = Control flow, cubic inches/sec
- K = Valve constant
- ΔP = Valve pressure drop

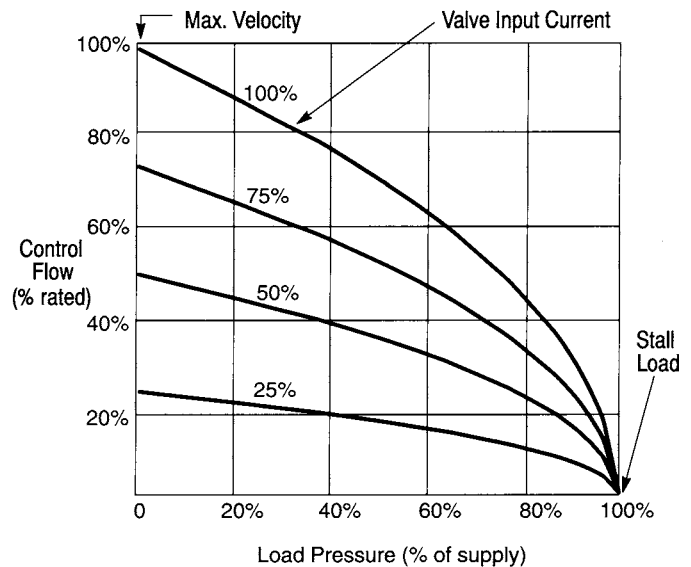

Figure 1. Change in flow with current and load pressure

**Quick Reference Data Chart**

Model	Flow Capacity @ 1000 PSID LPM (GPM)	Max. Pressure Rating	Max. Tank Pressure	Port Circle	Electrical Input (Std.) Single Coil	Coil Resistance (Std.) Each Coil	Weight
BD15	3.8, 9.5, 19, 37, 57, 76 (1, 2.5, 5, 10, 15, 20)	210 Bar (3000 PSI)	14 Bar (200 PSI)	.875	60 mA (Full Flow)	60 ohms	1.2 kg (2.6 lbs.)
BD30	76, 95, 113, 151 (20, 25, 30, 40)	210 Bar (3000 PSI)	14 Bar (200 PSI)	1.75	60 mA (Full Flow)	60 ohms	2.9 kg (6.3 lbs.)

BD.p65, dd



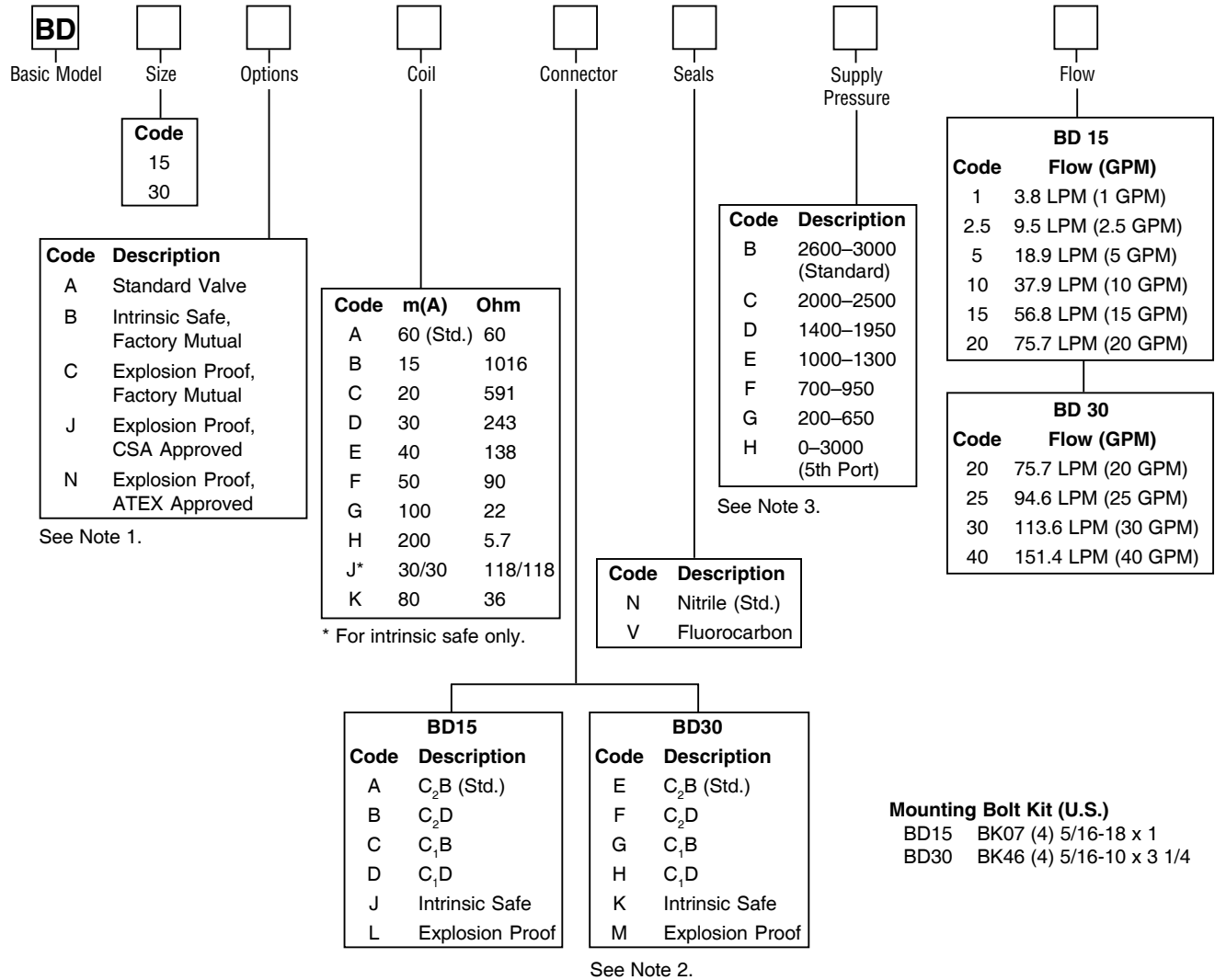

**Note 1: “B” Intrinsic Safe Option meets** Factory Mutual Intrinsically Safe Class I, II and III, Division 1 Groups A through G. Refer to Parker Bulletin 1452.

**“C” Explosion Proof meets:**  
 Factory Mutual Explosion Proof  
 Class I, II, III, Division 1, Groups A through G

**“J” Explosion Proof meets:**  
 Canadian Standards Association  
 Class I, Groups A through D  
 Class II, Groups E, F and G  
 Class III  
 Refer to Parker Bulletin 1451.

**“N” Explosion Proof meets:**  
 ATEX  $\text{Ex}$  II2G EExm II T3 T<sub>amb</sub> 45°C to -50°C  
 Request Parker Documentation Package: 1200074

**Note 2:** Connector Location & Flow Polarity  
 (Standard connector over C<sub>2</sub> + to B = P to C<sub>1</sub> flow).  
 C<sub>2</sub>B = Connector over Port C<sub>2</sub> + to Pin B = P to C<sub>1</sub> flow.  
 C<sub>2</sub>D = Connector over Port C<sub>2</sub> + to Pin D = P to C<sub>1</sub> flow.  
 C<sub>1</sub>B = Connector over Port C<sub>1</sub> + to Pin B = P to C<sub>1</sub> flow.  
 C<sub>1</sub>D = Connector over Port C<sub>1</sub> + to Pin D = P to C<sub>1</sub> flow.

**Note 3:** Supply Pressure: Code “H” applies to 5th Port/External Pilot Option. This requires the use of a blank orifice “-00”. First stage pressure should be limited to 41.4 Bar (600 PSI) and no less than 27.6 Bar (400 PSI).  
 Servo valve rated flow at 1000 PSID ±10%.

**Accessories**

Model	Description	Model	Description
6522A11	1/16" Hex Allen Wrench	820089-1	BD30 Servovalve Shipping Container
810005-1	Orifice Filter	BD830008	BD90/95 Amplifier Board Shipping Container
810013-**	Valve Orifice Kit, Fluorocarbon		
810014-**	Valve Orifice Kit, Nitrile	810089-1	BD15 Servovalve Shipping Container
<b>**Dash #</b>	<b>Operating Pressure</b>	820000TF3	Filter Wrench
-16	180 – 210 Bar (2600 – 3000 PSI)	MS3106E-14S-2S	SV Mating Connector
-18	138 – 176 Bar (2000 – 2550 PSI)		
-20	96 – 134 Bar (1400 – 1950 PSI)		
-22	69 – 93 Bar (1000 – 1350 PSI)	1200127	Flushing valve for BD15
-33	48 – 66 Bar (700 – 950 PSI)		
-50	14 – 45 Bar (200 – 650 PSI)		
-00	0 – 210 Bar (0 – 3000 PSI) 5th Port	1200128	Flushing valve for BD30

**Adapters**

□  
Type of Adapter

Code	To Mount A _____	Onto A _____ Pattern
810092-1	BD15	BD30 (1.75)
810093-5	BD15	D05
810094-5	BD15	D03
810098-1	BD15	.937 Port Circle
810097-3	BD15	.785 Port Circle
810096-5	BD15	.625 Port Circle
820006-1	BD30	Moog 62-303B & Atchley 231
820007-1	BD30	D08
820091-1	BD30	BD15 (.875)
820092-1	BD30	2.00 Port Circle
Consult Factory	BD30	1.375
Consult Factory	BD15	D05H

□  
Seals

Code	Description
Omit	Nitrile
V	Fluorocarbon

**Subplates**

Valve Model	Subplate	Port Size	Location	Bolt Kit	Torque Specifications (Lubricated)
BD15	810090-3	SAE12	Side	BK07	17 ft. lbs.
BD30	820090-3	SAE16	Side	BK46	17 ft. lbs.

**Cables**

**EHC**  
 Electrohydraulic  
 Cable for BD  
 Series Valves

□  
Length

Code	Length
9	Length
15	in Feet

**4**  
Cable Type

Code	Description
4	4-wire, 20 awg. shielded Belden 9402)

**S**  
Pin Orientation

Code	Description
S	BD Series

**Series BD15**

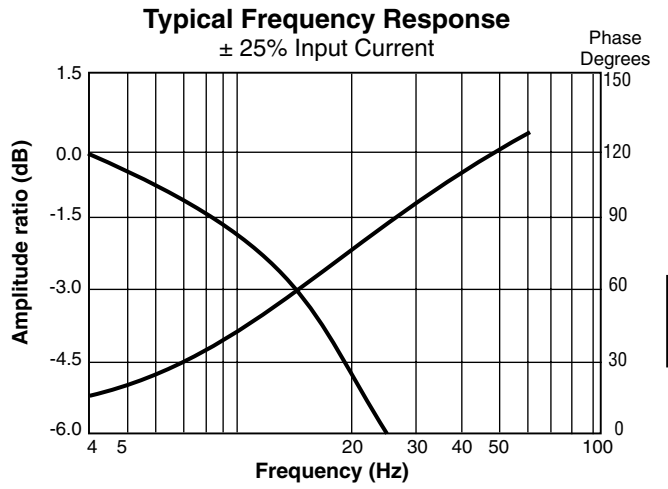
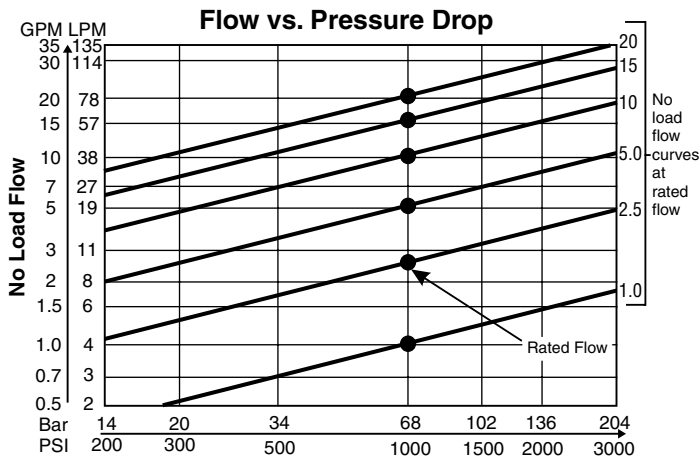

**Series BD30**

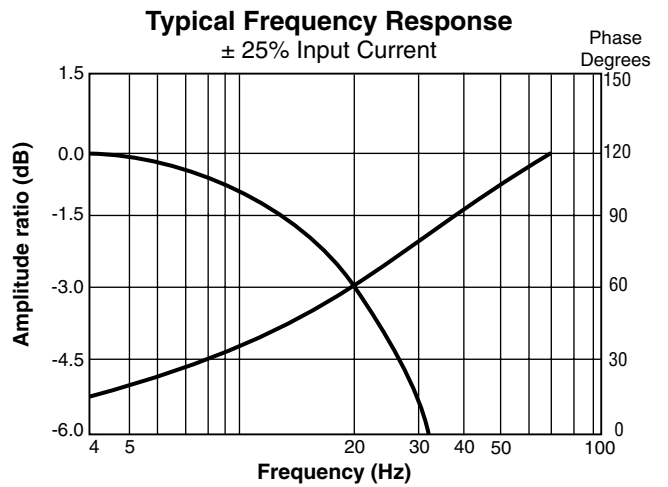
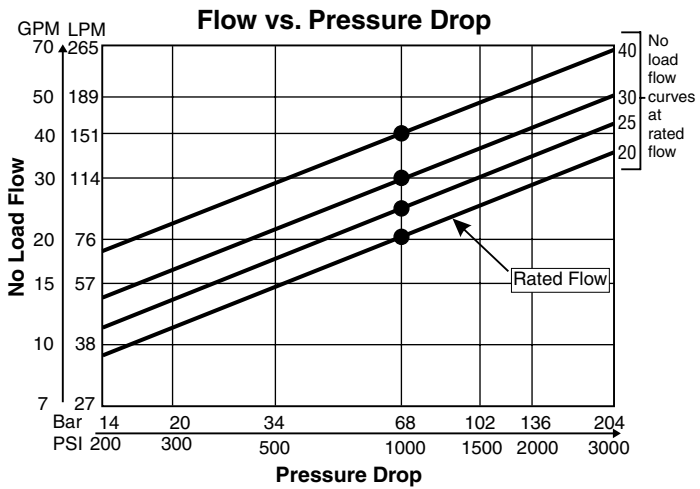

Inch equivalents for millimeter dimensions are shown in (\*\*)

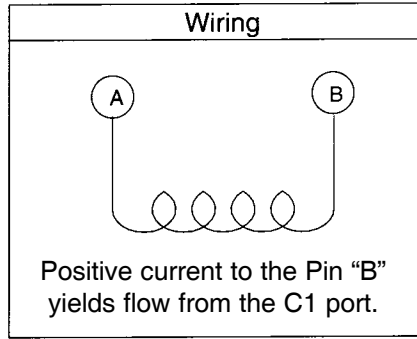
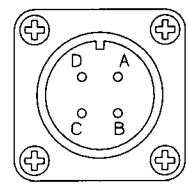
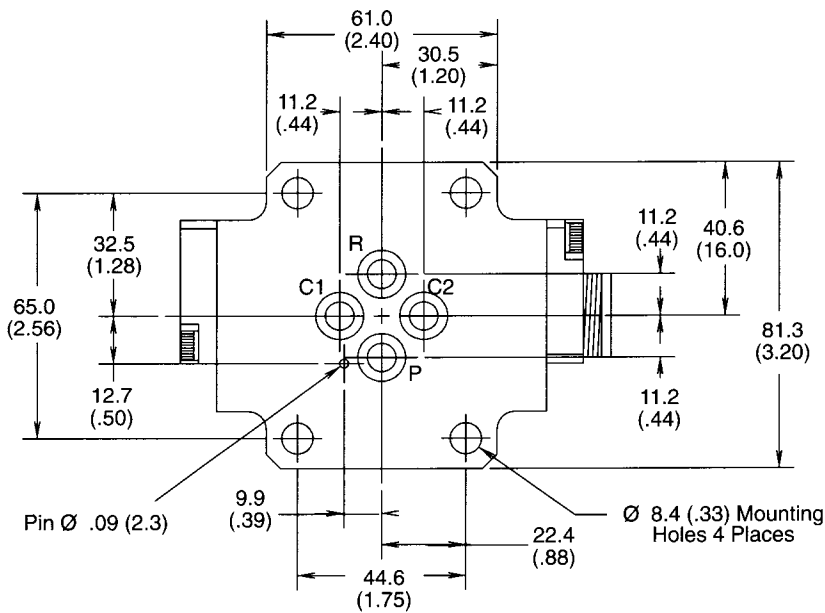
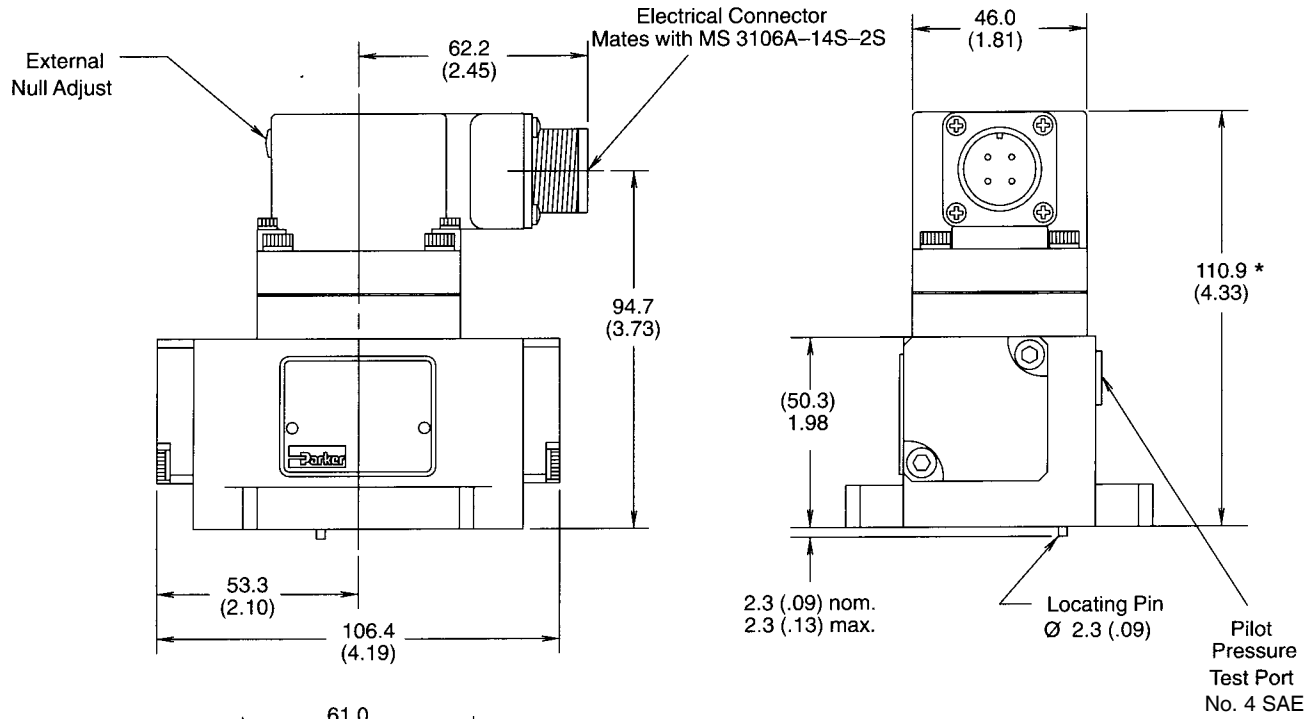

Note: Valve mating surface to be flat within 0.002 TIR, and smooth to within 63 RMS

\* 140 (5.50) for BD15C; explosion proof, FM approved.  
Note: Vertically oriented 1/2 NPT threaded male conduit connection with lead wires (not as shown).

Inch equivalents for millimeter dimensions are shown in (\*\*)

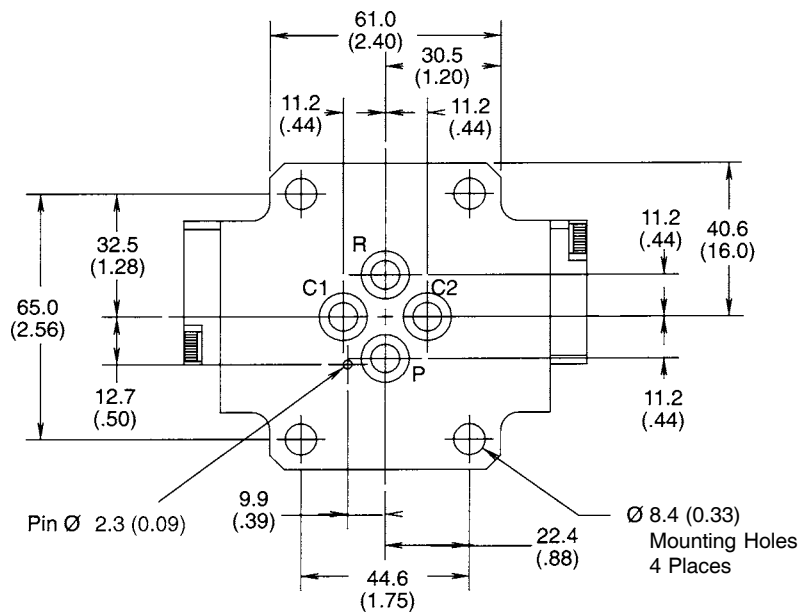
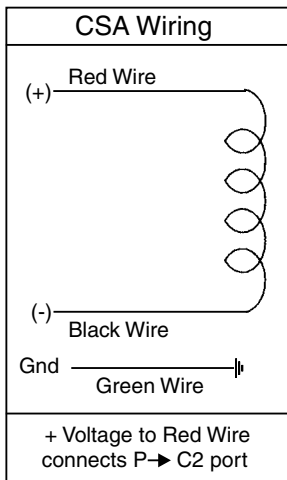
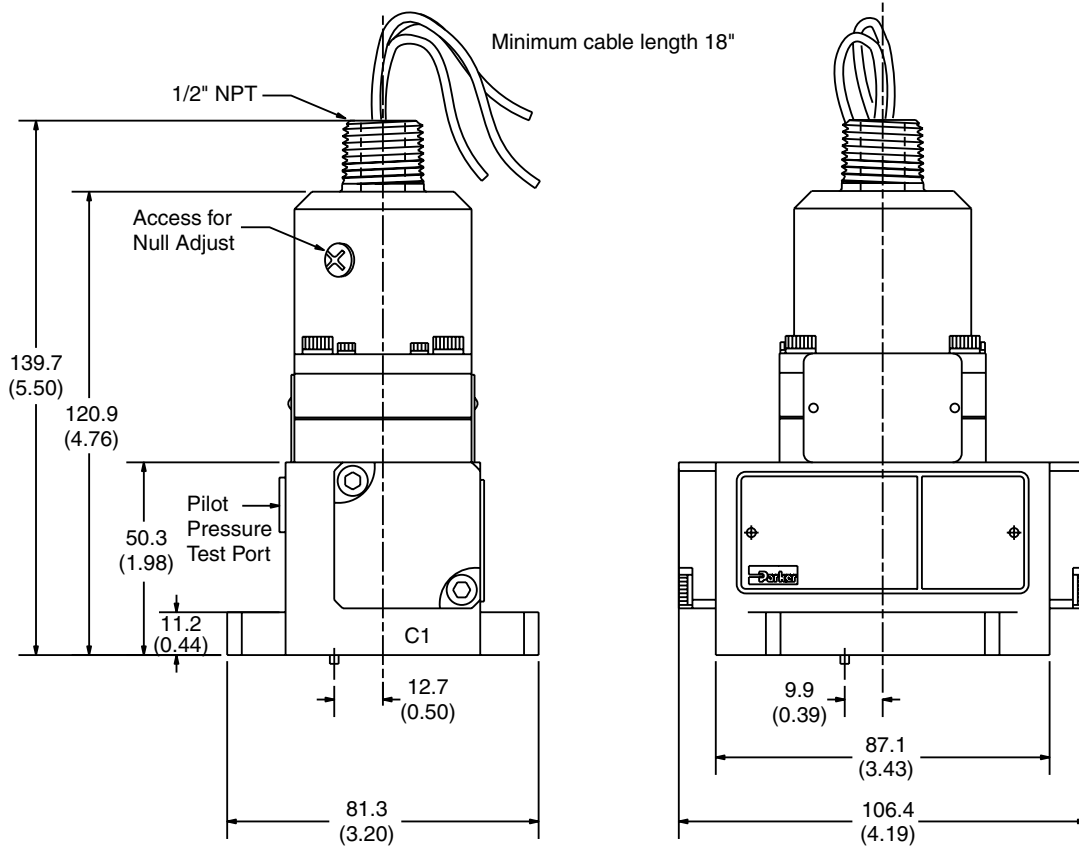

Note: Valve mating surface to be flat within 0.002 TIR, and smooth to within 63 RMS



Inch equivalents for millimeter dimensions are shown in (\*\*)

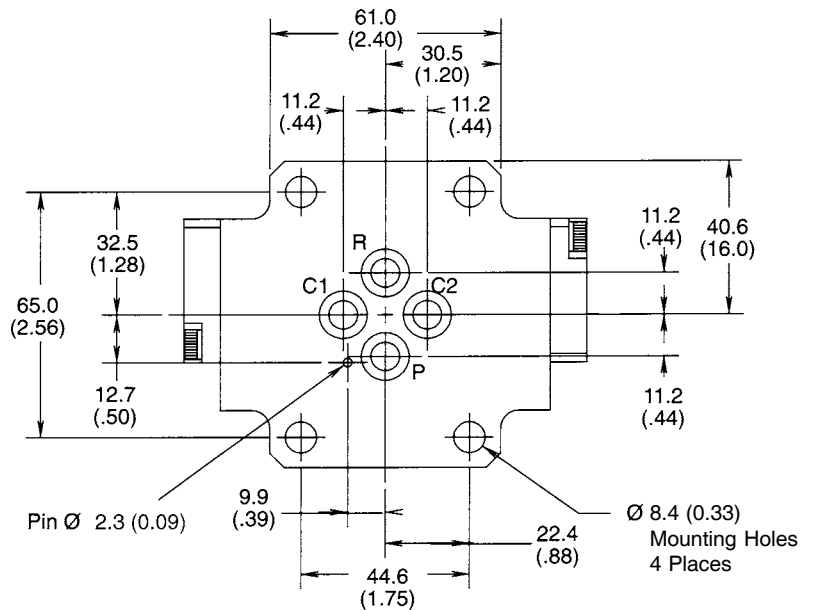
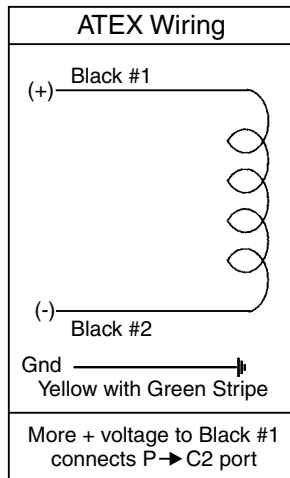
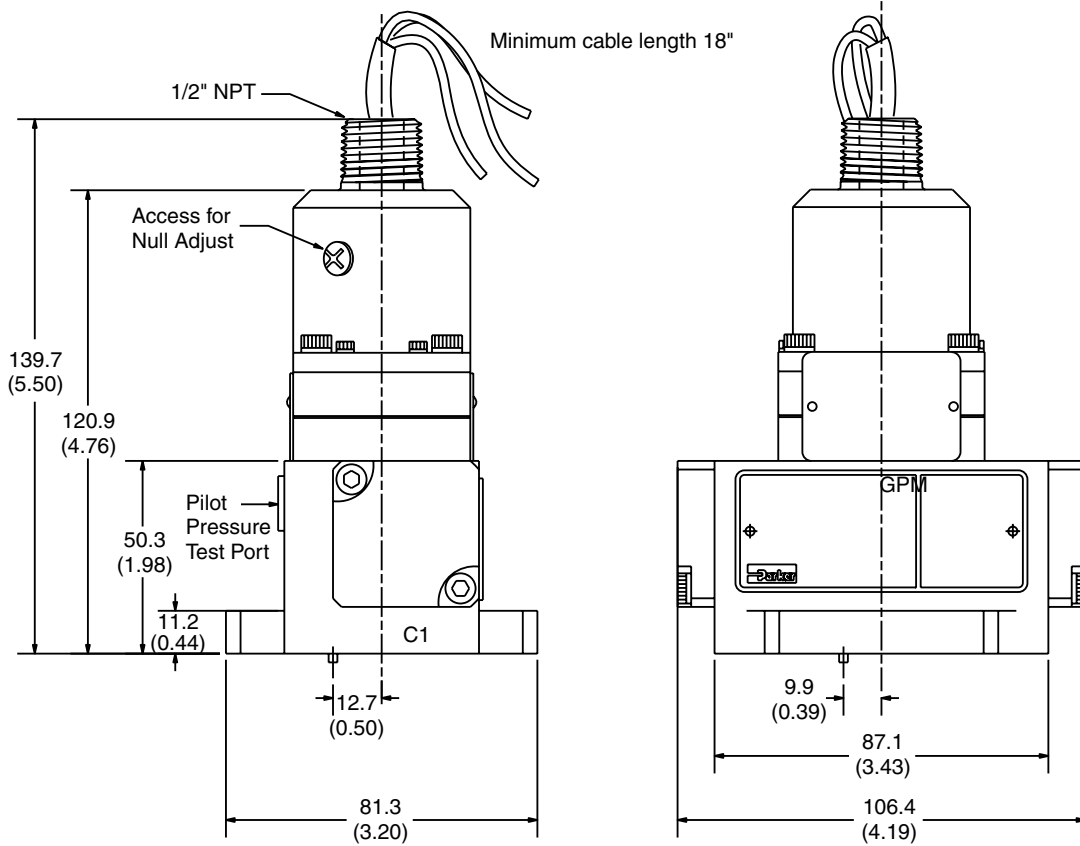

Note: Valve mating surface to be flat within 0.002 TIR, and smooth to within 63 RMS

Inch equivalents for millimeter dimensions are shown in (\*\*)

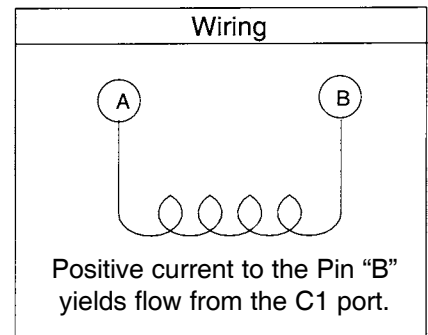
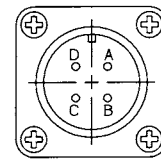
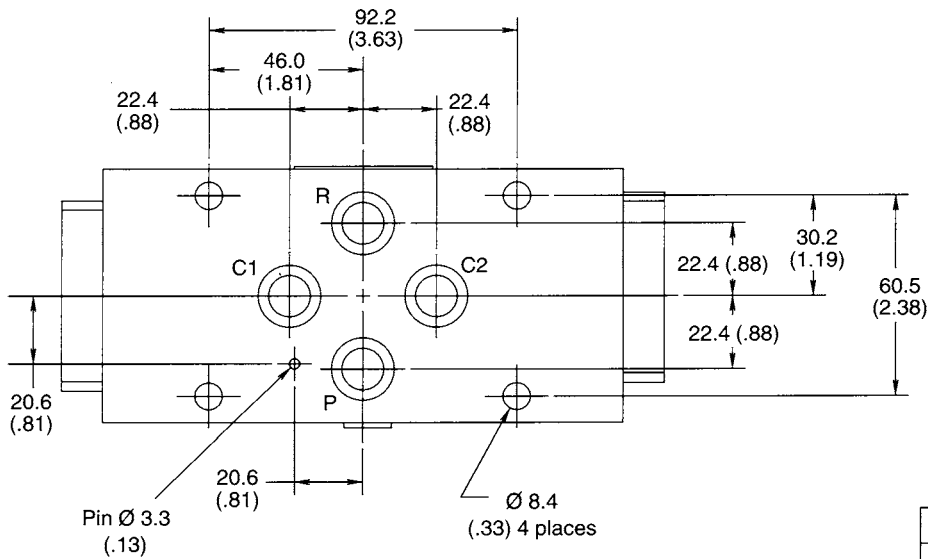
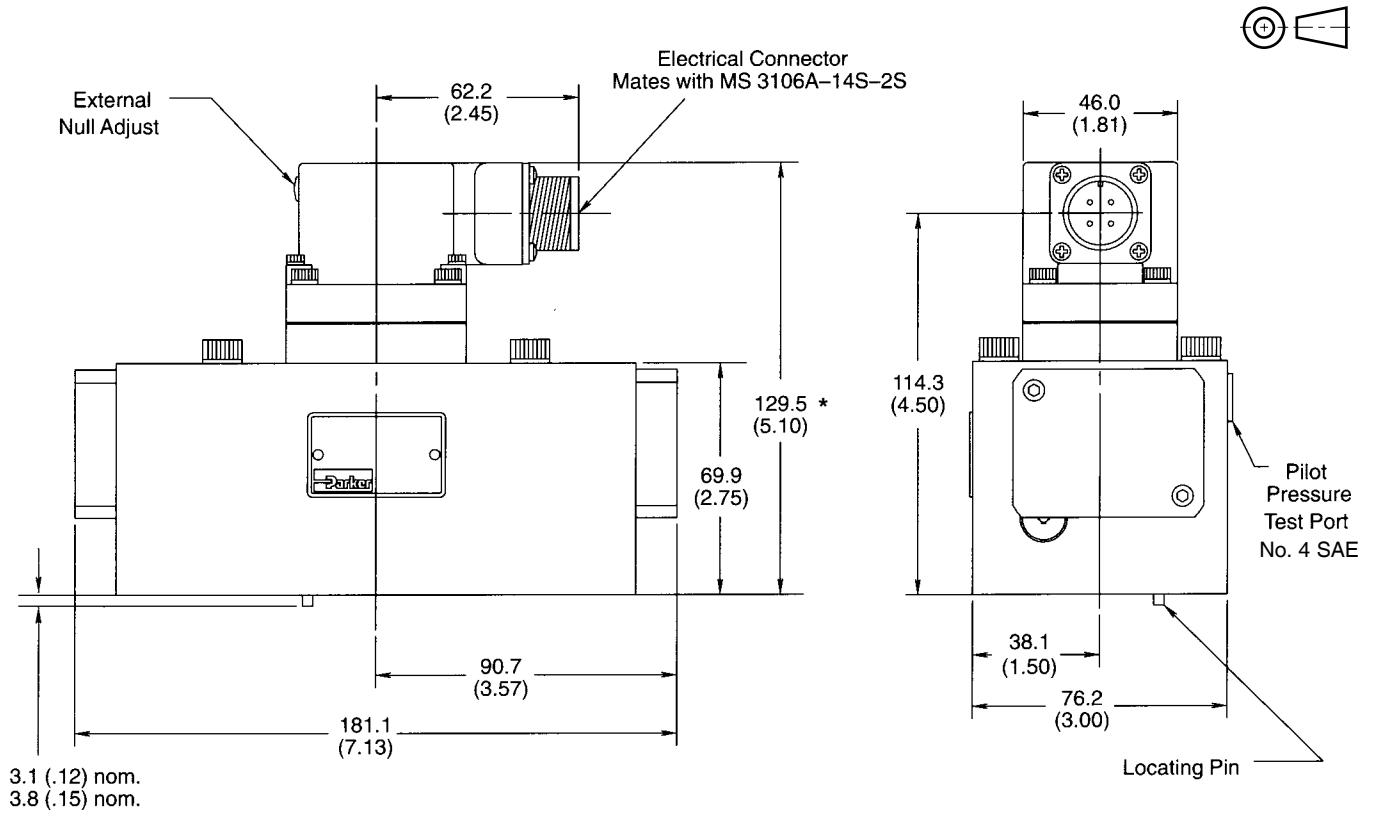

Note: Valve mating surface to be flat within 0.002 TIR, and smooth to within 63 RMS

\* 160 (6.25) for BD30C; explosion proof, FM approved.  
Note: Vertically oriented 1/2 NPT threaded male conduit connection with lead wires (not as shown).



**Dimensions**

**Series BD30, CSA Version BD30J\*M**

Inch equivalents for millimeter dimensions are shown in (\*\*)

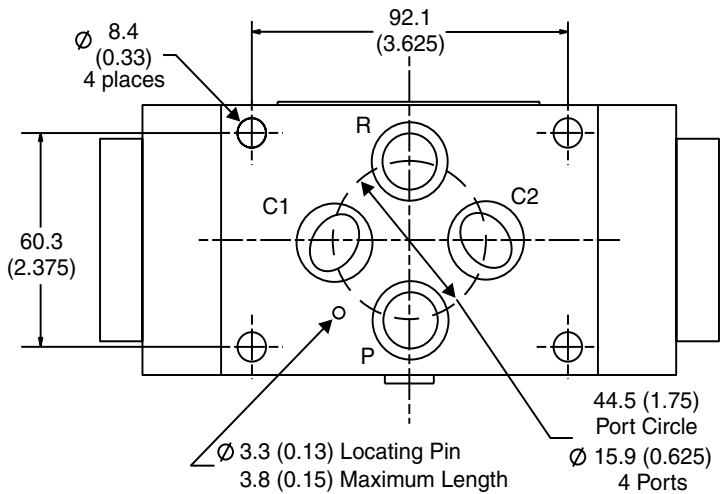
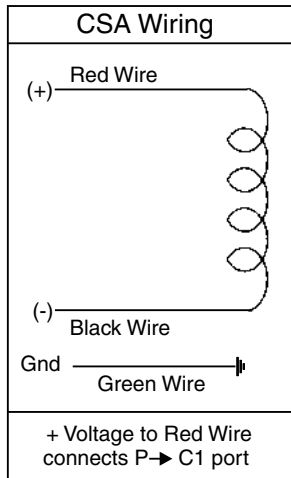
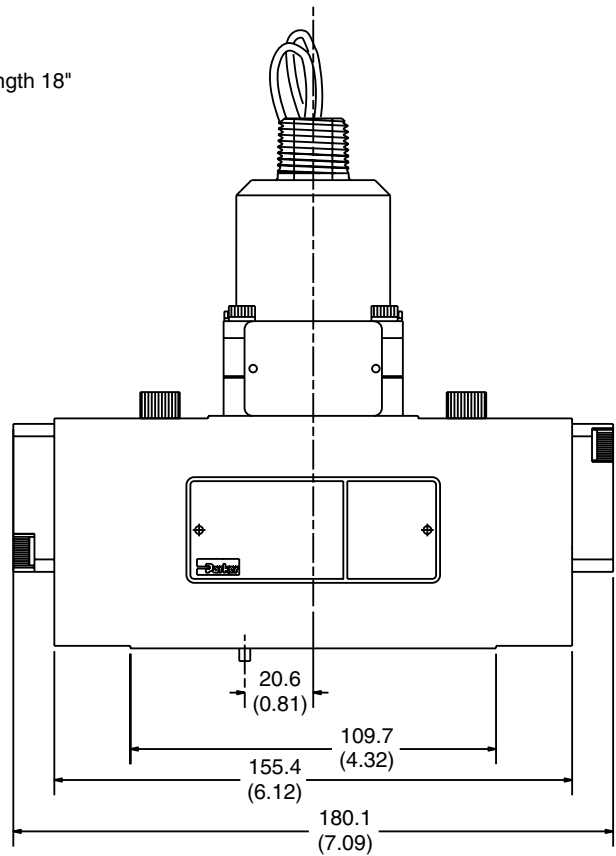
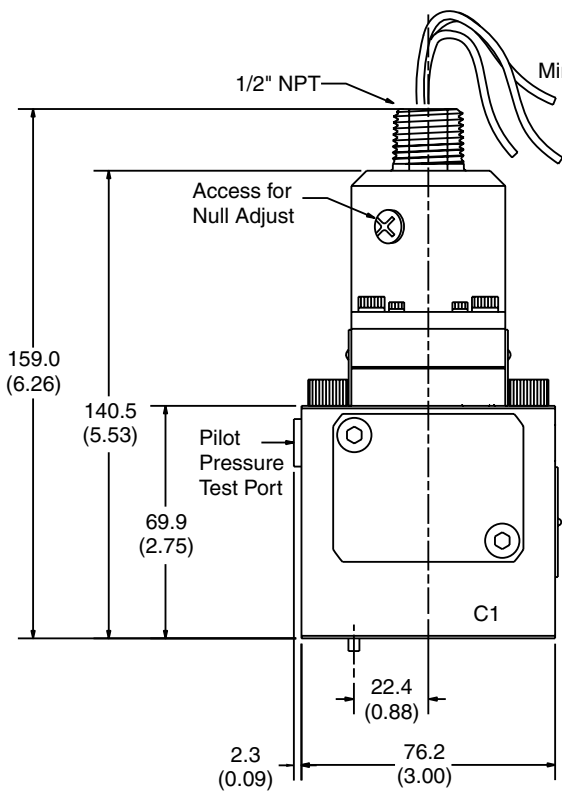

Note: Valve mating surface to be flat within 0.002 TIR, and smooth to within 63 RMS

**Dimensions**

**Series BD30, ATEX Version BD30N\*M**

Inch equivalents for millimeter dimensions are shown in (\*\*)

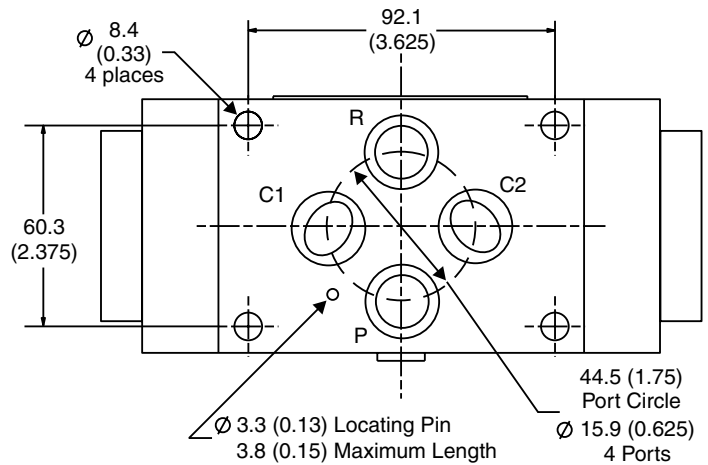
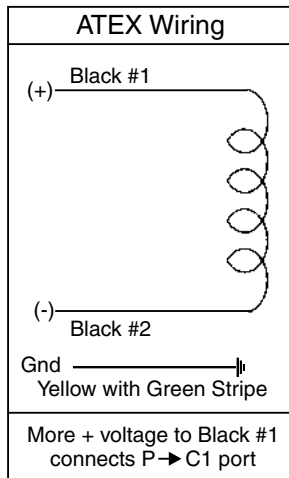
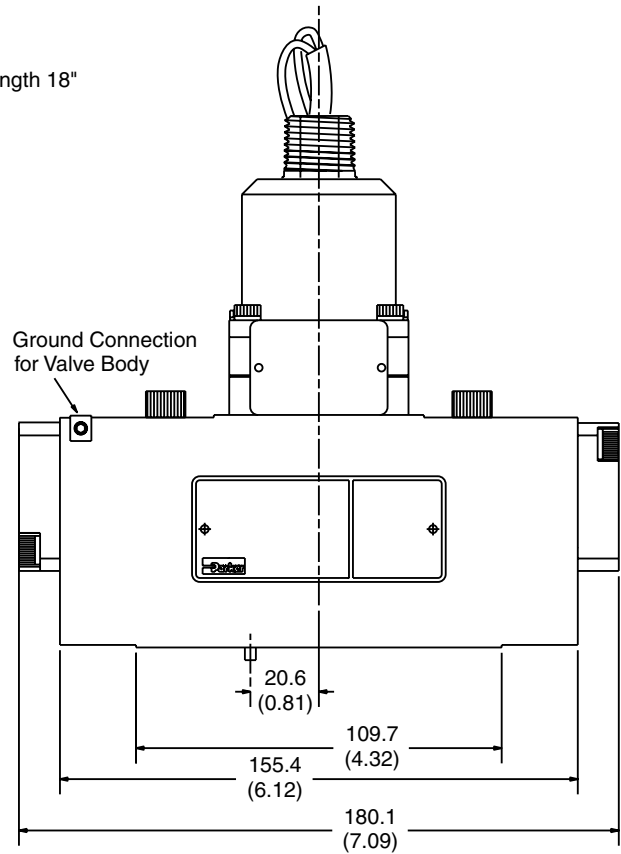
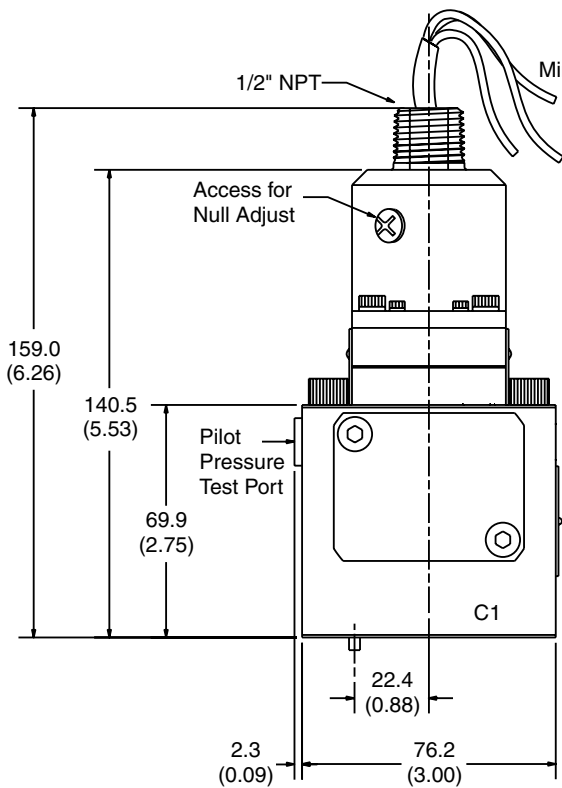

Note: Valve mating surface to be flat within 0.002 TIR, and smooth to within 63 RMS