



Wood Fire



HOT WATER
& HEATING

By PAUL AGNEW | DESIGNS®

P 02 9524 1856

| sales@hwhs.com.au

| www.hwhs.com.au



HOT WATER
& HEATING

By PAUL AGNEW | DESIGNS®



Wood Fire

Inbuilt Pyro Series
Wood Fireplaces

WOOD

Manufactured in both cast iron and steel, our range of wood fireplaces combines traditional design and modern technology for a beautiful and efficient solution.

Choose from standard or guillotine door access, as well as tunnel view design, and a bio ethanol accessory so you can enjoy the ambiance of flickering flames in warmer months.



Modica

six hundred inbuilt

This beautifully crafted cast iron wood fire is sure to catch your eye, whether installed as a built-in or left freestanding, the high-quality craftsmanship guarantees reliability and durability.

Designed for modern living, the Modica fireplace unit will add ambiance and warmth to any room.

Whether trying to achieve an industrial look by leaving the firebox exposed, or install it into a masonry fireplace, this versatile firebox offers the flexibility to create a multitude of design spaces.

Features

- Secure swing door opening system
- Regulation of air supply for combustion
- Built-in damper control
- Dual combustion heating system: radiant and natural convection exclusive to the inbuilt model
- Multi-room heating advantage exclusive to the inbuilt model
- Removable grate for easy cleaning
- Heat resistant glass withstands temperatures of 800°C
- Minimalist frame with seamless glass edge



Siena

seven fifty inbuilt

This beautifully crafted cast iron wood fire is sure to catch your eye, whether installed as a built-in or left freestanding, the high-quality craftsmanship guarantees reliability and durability.

Designed for modern living, the Siena fireplace unit will add ambiance and warmth to any room.

Whether trying to achieve an industrial look by leaving the firebox exposed, or install it into a masonry fireplace, this versatile firebox offers the flexibility to create a multitude of design spaces.

Features

- Secure swing door opening system
- Regulation of air supply for combustion
- Built-in damper control
- Radiant combustion heating system
- Removable grate for easy cleaning
- Heat resistant glass withstands temperatures of 800°C
- Minimalist frame for modern design
- Optional external primary air intake
- Heats up to 290 sqm
- Thermal efficiency 80%



Como

seven fifty guillotine

This contemporary wood fire insert features the traditional functional elements of a wood fire while still offering an extraordinary heating performance.

With the flexibility of an open fireplace or slow combustion heater, this wood fire is sure to complement any design aesthetic.

Features

- Dual combustion heating system: radiant and natural convection
- Rise-and-fall glass door – conveniently opening on a smooth guillotine pulley system
- Primary, secondary and tertiary combustion with control
- Child safety lock available on the glass door
- Removable grate for easy cleaning
- Multi-room heating advantage
- Heat resistant glass withstands temperatures of 800°C
- Minimalist frame with blackened glass edge for modern design
- Optional external primary air intake
- Heats up to 290 sqm
- Thermal efficiency 80%



Siena

seven fifty tunnel inbuilt

This modern minimalist wood heater can blend into a multitude of design interiors, with the flexibility to be used as an open fireplace or slow combustion unit, this double-sided fireplace will make a statement in any open-plan space.

Designed to be enjoyed from both sides, this is the perfect unit to divide any space.

Placed in the center of a room, or even the most modern warehouse conversion, this beautifully crafted cast iron is sure to catch your eye.

Whether installed as a built-in or left freestanding, the high-quality craftsmanship guarantees reliability and durability.

Features

- Secure swing door opening system
- Regulation of air supply for combustion
- Built-in damper control
- Dual combustion heating system: radiant and natural convection exclusive to the inbuilt model



Siena

seven fifty four sided inbuilt

This modern minimalist wood heater can blend into a multitude of design interiors, with the flexibility to be used as an open fireplace or slow combustion unit, this double-sided fireplace will make a statement in any open-plan space.

Designed to be enjoyed from both sides, this is the perfect unit to divide any space.

Placed in the center of a room, or even the most modern warehouse conversion, this beautifully crafted cast iron is sure to catch your eye.

Whether installed as a built-in or left freestanding, the high-quality craftsmanship guarantees reliability and durability.

Features

- Secure swing door opening system
- Regulation of air supply for combustion
- Built-in damper control
- Radiant combustion heating system
- Removable grate for easy cleaning
- Heat resistant glass withstands temperatures of 800°C
- Minimalist frame for modern design
- Optional external primary air intake
- Heats up to 290 sqm
- Thermal efficiency 80%



Toscani

seven fifty peninsula

Spectacular from any angle, this three-sided unit is manufactured to the highest quality.

With 4mm thick steel and a refractory combustion chamber lined with ceramic blocks, this built-in fireplace offers functional specifications.

Its unconventional glass viewing area, minimalist frame, and elegant glass door highlight the luxury designs directly from Europe.

The perfect unit to mesmerise any space, this wood heater can be used in a multitude of design environments.

Whether placed in the middle of the room or coming off the wall to create a striking room divider, there is no limit to the design aesthetics available to this fireplace.

Features

- Rise-and-fall glass door – conveniently opening on a smooth pulley system
- Improved strength and performance with a ceramic-lined combustion chamber
- Primary, secondary and tertiary combustion with control
- Child Safety lock available on the glass door
- Dual combustion heating system: radiant and natural convection
- Multi-room heating advantage
- Heat resistant glass withstands temperatures of 800°C
- Minimalist frame with blackened glass edge for modern design
- Optional external primary air intake
- Heats up to 120 sqm
- Thermal efficiency 80%



Tivoli

eight hundred inbuilt

Effortlessly elegant, the Tivoli wood fire features a traditional look with a twist of modernism.

Its clean lines and blackened glass edge ensure that it can be situated into any design element, the perfect fireplace to install into an existing fireplace with a mantle accessory or featured alone.

With functionality at its core, this wood fire is sure to impress, its high-quality craftsmanship guarantees reliability and durability.

The simplicity of the Tivoli creates an enticing environment of beauty and warmth.

Features

- Secure swing door opening system
- Primary, secondary and tertiary combustion with control
- Dual combustion heating system: radiant and natural convection
- Multi-room heating advantage
- Heat resistant glass withstands temperatures of 800°C
- Minimalist frame with blackened glass edge for modern design
- Optional external primary air intake
- Heats up to 170 sqm
- Thermal efficiency 80%



Vittoria

nine fifty guillotine

The Vittoria Nine Fifty offers the sleek elegance of a panoramic wood heater.

With a wide view of the fire and a convenient and easy to use rise-and-fall glass door, the Vittoria is sure to add a statement to any space.

With an exceptional heat output and minimalist design, this inbuilt fireplace offers the flexibility of an open fireplace or slow combustion heater.

Features

- Rise-and-fall glass door – conveniently opening on a smooth pulley system
- Improved strength and performance with a ceramic-lined combustion chamber
- Primary, secondary and tertiary combustion with control
- Child Safety lock available on the glass door
- Dual combustion heating system: radiant and natural convection
- Multi-room heating advantage
- Heat resistant glass withstands temperatures of 800°C
- Minimalist frame with blackened glass edge for modern design
- Optional external primary air intake
- Heats up to 210 sqm
- Thermal efficiency 80%



Vittoria

nine fifty tunnel guillotine

This stunning double-sided fire highlights the elegance of a panoramic wood heater sought after by those who prize a minimalist design and an incredible heating performance.

The Vittoria 950 Tunnel will make an impressive statement in any space, with smooth guillotine-style doors, and a ceramic brick-lined chamber, this unit emphasizes the impeccable craftsmanship direct from Europe.

With a playful design, this range of wood fires creates a warmth and ambiance in any centre space while also providing the core elements of a wood fire.

Features

- Rise-and-fall glass door – conveniently opening on a smooth pulley system
- Improved strength and performance with a ceramic-lined combustion chamber
- Primary, secondary and tertiary combustion with control
- Child Safety lock available on the glass door
- Dual combustion heating system: radiant and natural convection
- Multi-room heating advantage
- Heat resistant glass withstands temperatures of 800°C
- Minimalist frame with blackened glass edge for modern design
- Optional external primary air intake



Verona

twelve hundred guillotine

The stunning Verona wood fire is the perfect example of European luxury, featuring a large panoramic guillotine glass door, this contemporary wood fire allows for superior views of the flame and can be integrated into a multitude of design environments.

With its sleek design, this inbuilt wood heater is sure to create a focal point in any room.

Producing brilliant radiant and convection heat, as well as featuring our latest technology in heat distribution, this unit can be integrated into the most traditional of design aesthetics.

Its own air transfer system captures heat from the cavity that would otherwise have been lost in your chimney, allowing you to duct the heat off to other areas of your home.

This functional design maximises the efficiency in your home while allowing for the flexibility to be used as an open fireplace or slow combustion wood heater.

Features

- Rise-and-fall glass door – conveniently opening on a smooth pulley system
- Improved strength and performance with a ceramic-lined combustion chamber
- Primary, secondary and tertiary combustion with control
- Child Safety lock available on the glass door
- Dual combustion heating system: radiant and natural convection
- Multi-room heating advantage
- Heat resistant glass withstands temperatures of 800°C
- Minimalist frame with blackened glass edge for modern design
- Optional external primary air intake
- Heats up to 270 sqm
- Thermal efficiency 80%



PYRO SWING DOOR WOOD FIREPLACES

MODELS:
MODICA 600
SIENA 750
TIVOLI 800

MODICA 600

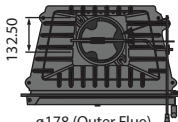
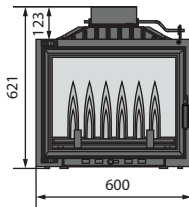
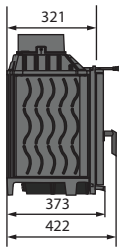

ø178 (Outer Flue)
ø168 (Inner Flue)

FREESTANDING & INBUILT

FREESTANDING & INBUILT

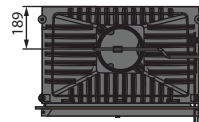
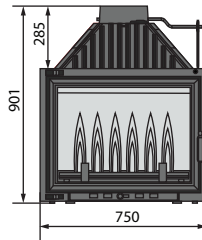

ø205.50 (Outer Flue)

SIENA 750

FREESTANDING
& INBUILT

SIENA 750 TUNNEL

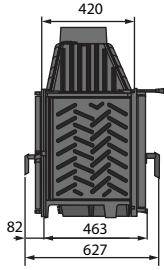
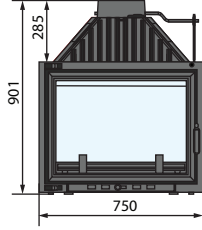
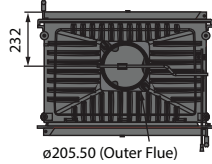

SIENA 750 LEFT CORNER

FREESTANDING
& INBUILT

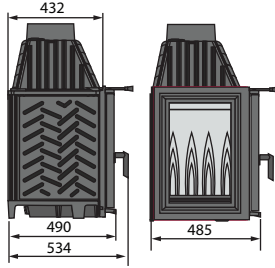
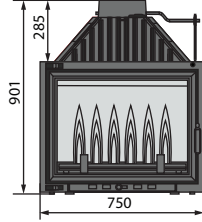
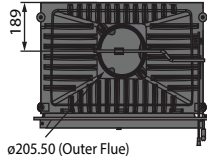

FREESTANDING
& INBUILT

SIENA 750 RIGHT CORNER

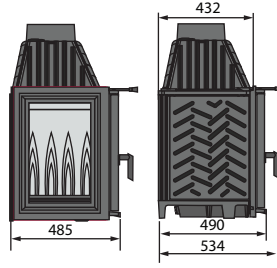
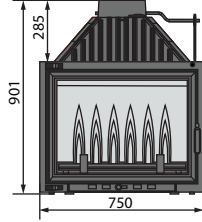
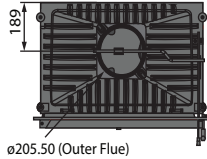

SIENA 750 3-SIDED

FREESTANDING
& INBUILT

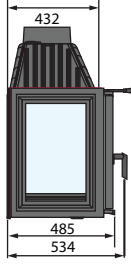
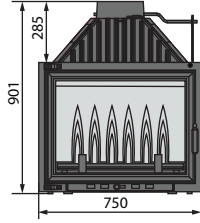
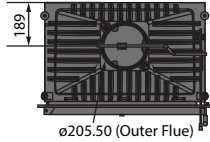

FREESTANDING
& INBUILT

SIENA 750 4-SIDED

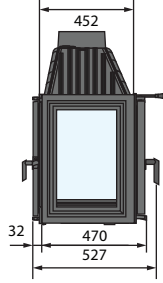
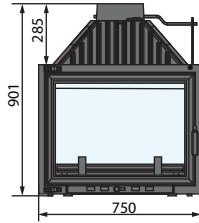
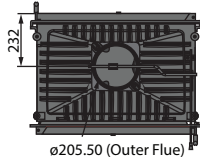

TIVOLI 800

INBUILT

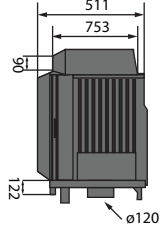
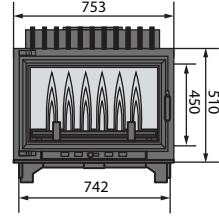
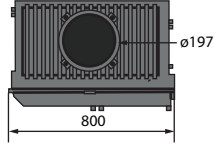

PAUL AGNEW | DESIGNS

PYRO GUILLOTINE WOOD FIREPLACES

MODELS:

COMO 750

TOSCANI 750

VITTORIA 950

VERONA 1200

COMO 750

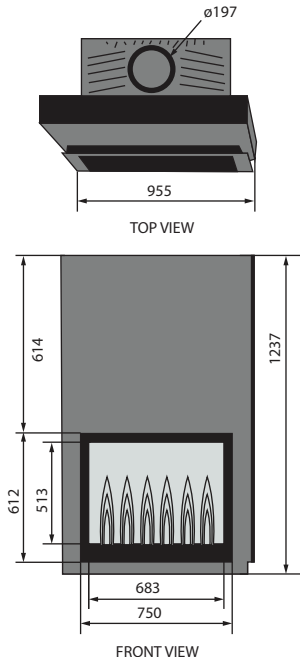

INBUILT

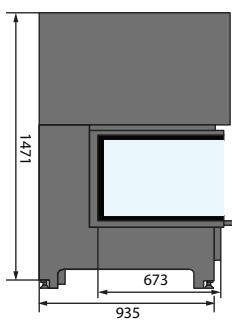

SIDE VIEW

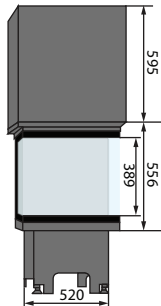

FRONT VIEW

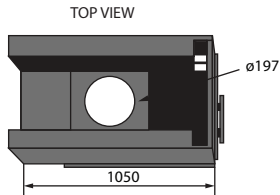

TOP VIEW

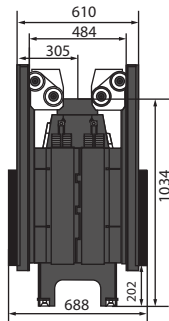

SIDE VIEW

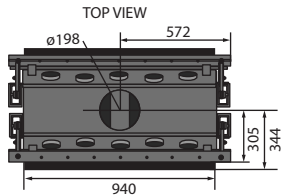

TOP VIEW

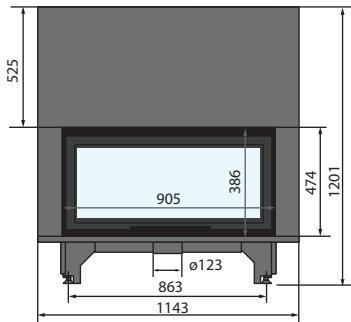

FRONT VIEW

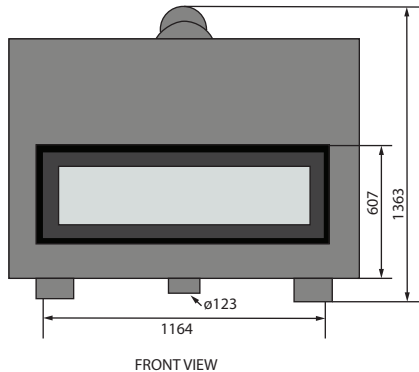
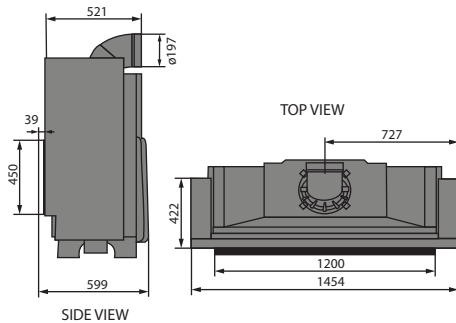
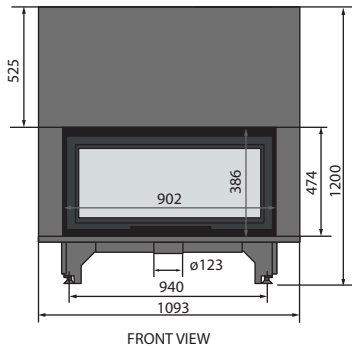
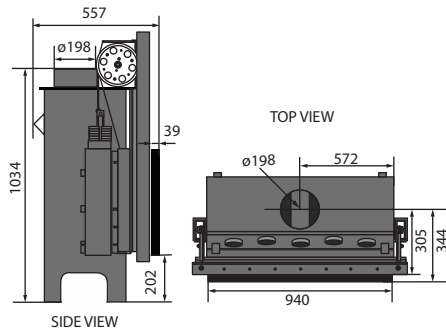

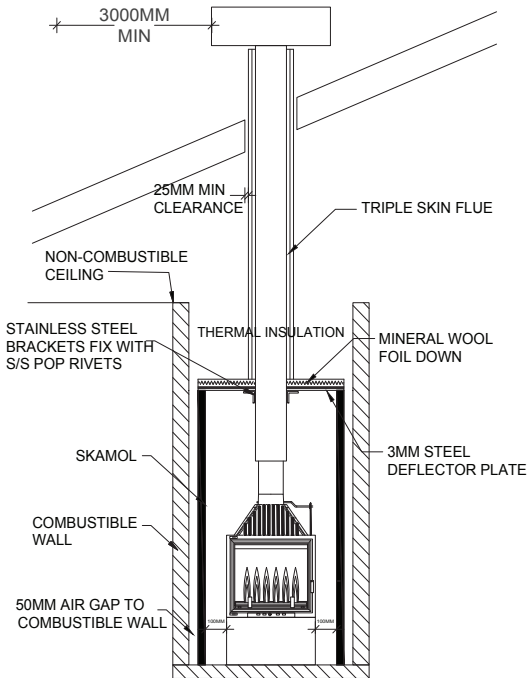

FRONT VIEW

- OPTION 1

PAUL AGNEW
DESIGNS

TOP VIEW & AIR FLOW AREA

TOP VIEW

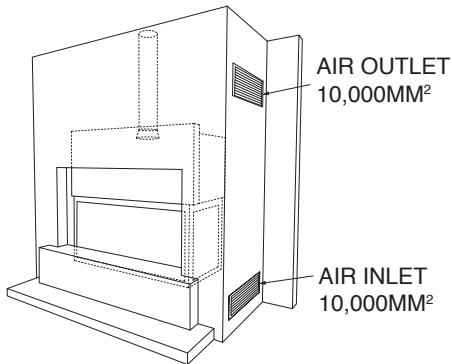
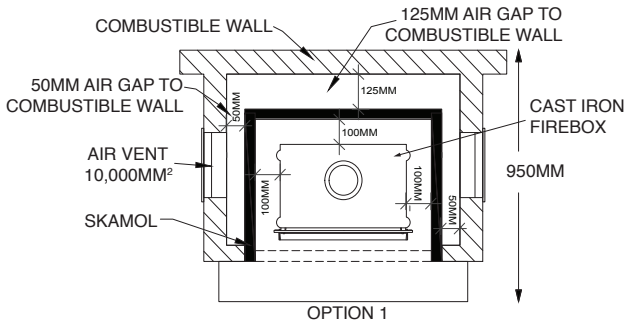

SIDE AIR INLET & OUTLET ENCLOSURE

- OPTION 1

PYRO
INBUILT
SWING
DOOR
SERIES

SIDE VIEW

SKAMOL
FIREPLACE
ENCLOSURE
SPECIFICATIONS
- OPTION 2

PAUL AGNEW
DESIGNS

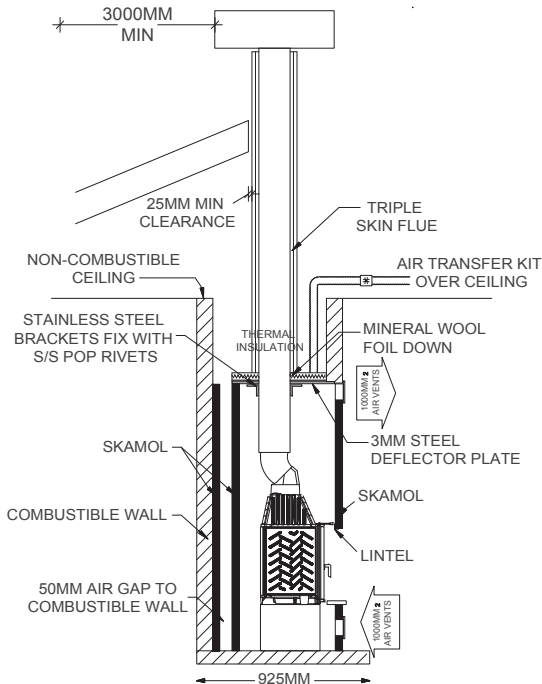

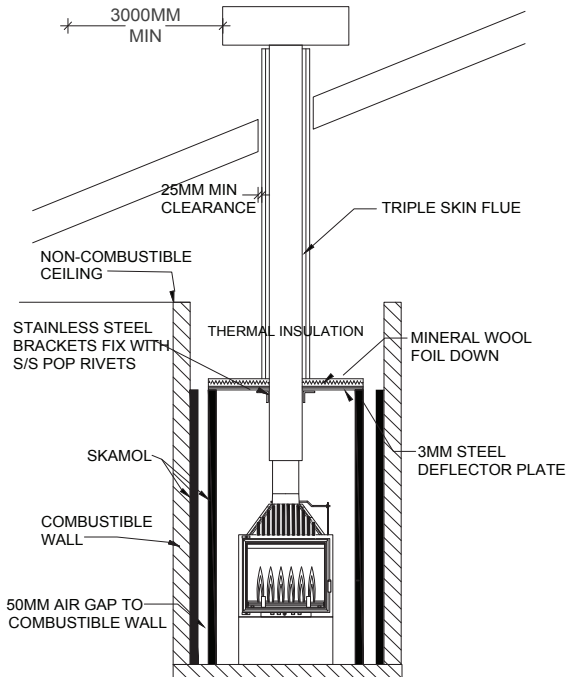

FRONT VIEW

- OPTION 2

PAUL AGNEW
DESIGNS

TOP VIEW & AIR FLOW AREA

TOP VIEW

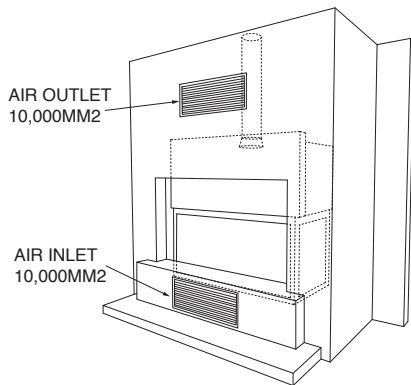
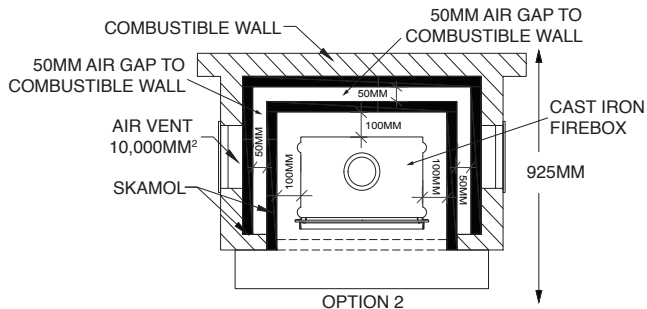

FRONT AIR INLET & OUTLET ENCLOSURE

- OPTION 2

PYRO GUILLOTINE SERIES

SIDE VIEW

SKAMOL FIREPLACE ENCLOSURE SPECIFICATIONS

PAUL AGNEW
DESIGNS

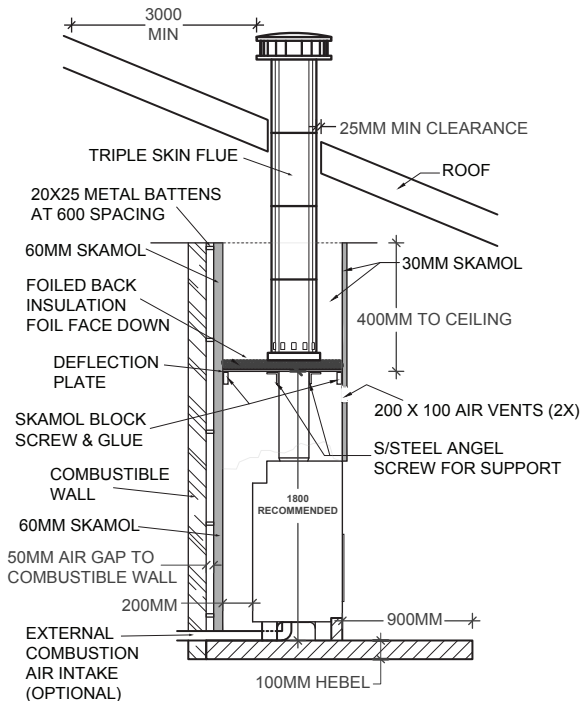

FRONT VIEW

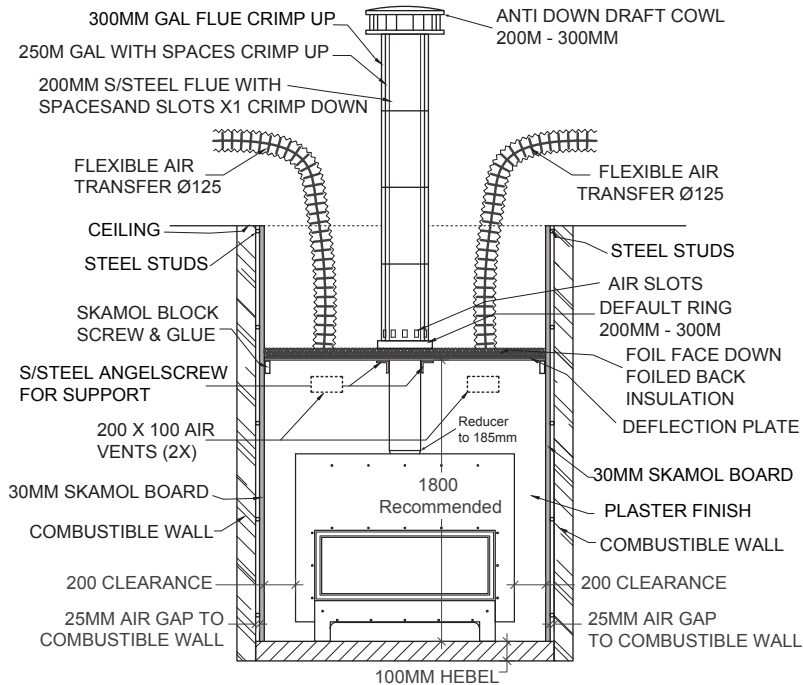

AIR FLOW AREA

AIR GRILLS - MINIMUM AIR FLOW AREA

ONE OF THE FOLLOWING OPTIONS:
(**ABOVE & BELOW**)

- 1 X FRONT GRILL 800MM²
- 1 X SIDE GRILL 400MM² ON EACH SIDE

GRILLS ARE REQUIRED **BOTH BELOW THE FIREBOX** WITHIN THE ENCLOSURE TO DRAW AIR IN (INLET) AS WELL AS **ABOVE THE FIREBOX** TO EXPELL HEATED AIR (OUTLET) INTO THE ROOM.

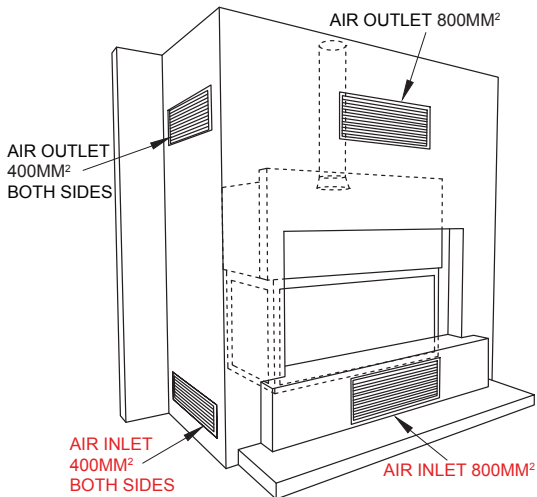

TOP VIEW

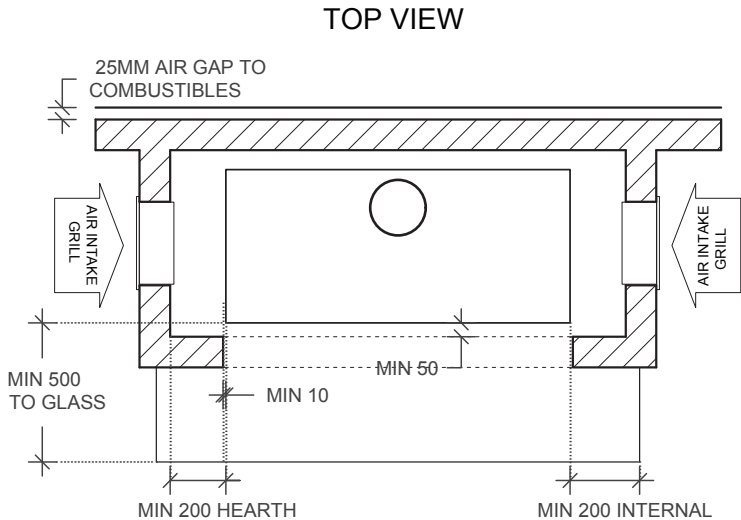

EXTERNAL CLEARANCES

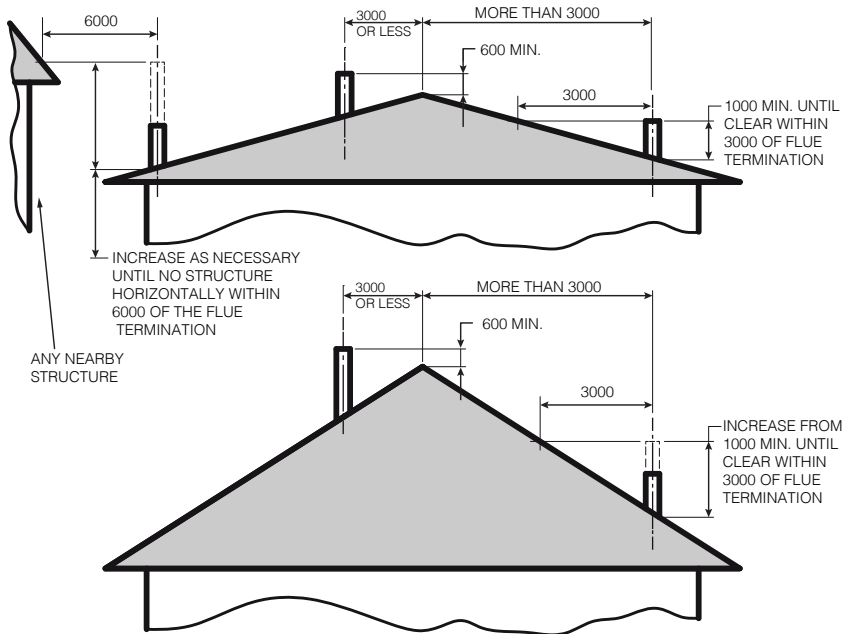

MINIMUM HEARTH CLEARANCE RATIOS

| HEIGHT OF APPLIANCE ABOVE FLOOR | LENGTH OF HEARTH FROM FRONT DOOR |
|------------------------------------|-------------------------------------|
| 200 | 700 |
| 300 | 660 |
| 400 | 600 |
| 500 | 520 |
| 600 | 410 |
| 700 | 300 |

THE INSTALLATION OF A HEARTH IS A MANDATORY REQUIREMENT WITH ALL WOOD FIREPLACES.

THEY MUST BE CONSTRUCTED FROM A NON-COMBUSTIBLE MATERIAL TO ENSURE THE PROTECTION OF TIMBER AND CARPET FLOORS.

HEARTHS ARE MORE OFTEN CONSTRUCTED FROM SLATE, STONE AND TILES, REFLECTING THE OTHER MATERIALS IN THE ROOM, ADDING A SENSE OF AMBIANCE AND GRANDEUR TO YOUR FIREPLACE.

THE SIZE OF THE HEARTH REQUIRED IS DIRECTLY PROPORTIONATE TO THE SIZE OF THE FIREPLACE.