



**GOTRAX**

# G Pro

ELECTRIC SCOOTER

**USER MANUAL**



**Congratulations  
on your purchase!**



## **GOTRAX**

This user manual will help you assemble and operate your new Electric Scooter. Be sure to read **ALL OF THE INFORMATION** in this manual before riding.

**NOTE TO ALL RIDERS UNDER 18 YEARS OF AGE:** It's very important that you get parental permission before riding your Electric Scooter.



# Don't ride until you read this



**ALWAYS** wear a helmet when riding your Electric Scooter.



Make sure your scooter has a **full battery** before taking it out to ride.



**Always** be aware of local road laws, and follow them.



**Do not** ride the scooter under the influence of drugs or alcohol.



**Always** respect pedestrians.



**Do not** ride under wet conditions. The scooter may slide from under your feet causing injury. Wet conditions may damage the electronics and void the warranty.



# Warning Message

1. **Avoid water** - The scooter is not waterproof. The electronics may be damaged due to water and water damage is not covered by our warranty. Riding in wet conditions is also very dangerous and may result in injury.
2. **Abuse** - We do not cover physical damage due to negligent care and extreme riding.
3. **Whenever you ride the GOTRAX electric scooter**, you risk severe injury or even death from loss of control, collisions, and falls. Use caution and ride at your own risk.
4. **Do not** modify the product from the manufacturer's original design.
5. **Keep** hands and all body parts away from moving parts while operating the scooter.
6. **Before riding** - be sure to check the scooter over and make sure the scooter is operating correctly before each use.
7. **Before riding** - be sure to check that the braking system is functioning properly; also be sure to check that all safety labels are in place and you understand the safety warnings.

8. **Before riding** - be sure that any and all axle guards, chain guards, or other covers or guards supplied by the manufacturer are in place and in serviceable condition.
9. **Before riding** - be sure to check that the tires are in good condition, inflated properly, and have sufficient tread remaining.
10. **Never** exceed the 220 lb (100 kg) maximum load rating.
11. The electric scooter should **never** be used by children under the age of 16.
12. **Maximum Speed** - Your electric scooter goes the maximum speed of 20 mph.



# Unpack

You should find each of these items in your box:

1. Electric Scooter
2. Approved Power Adapter / Charging Unit
3. 3mm Allen Wrench
4. Tire Pump Extender
5. 4 Screws

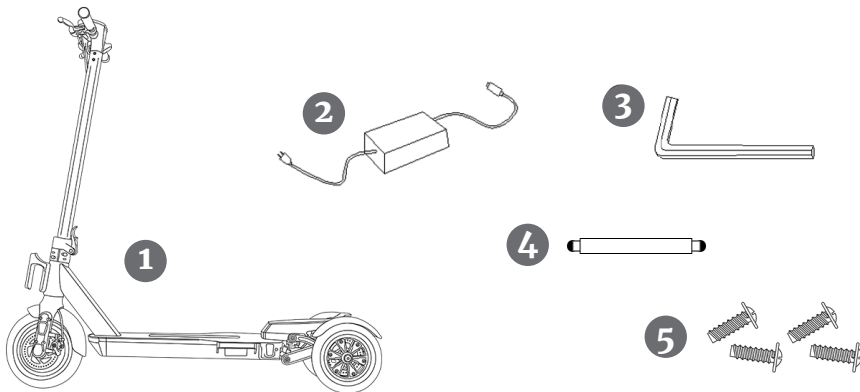

Remove all packaging material, then inspect each item for any accidental damage that may have occurred during shipping.



# Get to know your scooter

The electric scooter comes partially assembled.

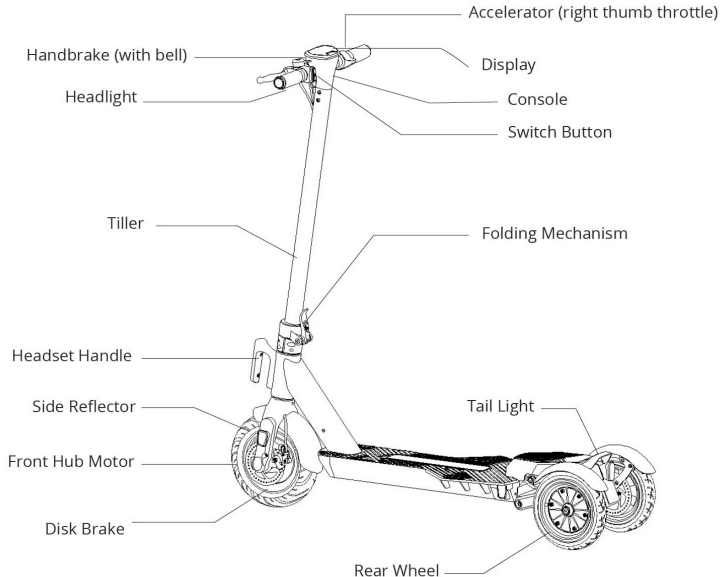

## SPECIFICATIONS

Top Speed:	20 mph
Distance per Charge:	24 Miles
Weight Range Up To:	220lbs
Battery Type:	36V 10.4AH
Battery Charger:	DC 42V 3.0A
Charge Time:	3-4 hours
Power Requirements:	AC 100-240V~50/60HZ 3.0A





# Assemble Your Scooter

1

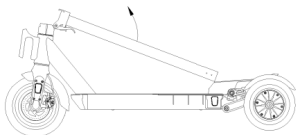

Straighten the tiller and lift the tiller upright (as shown in the figure).

2



Press the folding lever as the figure shows to lock the tiller.

3

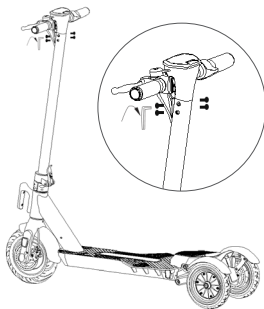

Insert the exposed cable into the tiller and then insert the console into the tiller. Use the tool and screws to lock the console into place. (as shown in the figure).



# Charge Your Scooter

**Before using the scooter, you must fully charge the battery.**

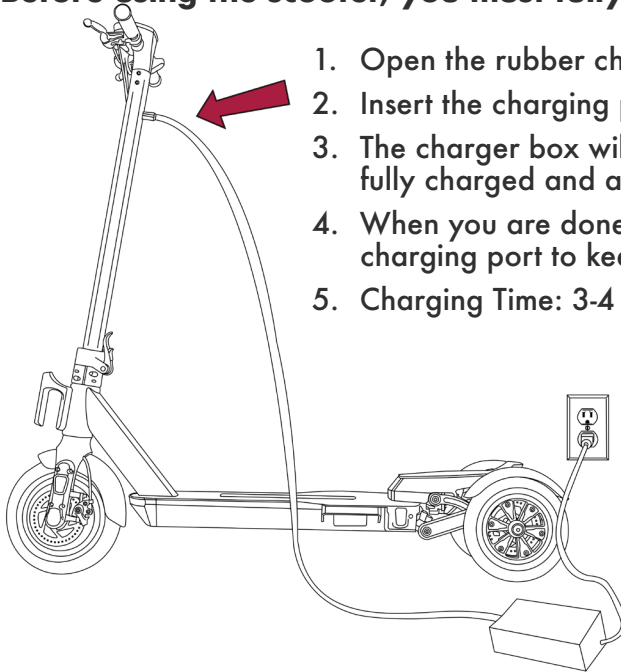

1. Open the rubber charging port cover.
2. Insert the charging plug into the port.
3. The charger box will have a green light when fully charged and a red light when charging.
4. When you are done charging be sure cover the charging port to keep it clear of dust and debris.
5. Charging Time: 3-4 hours

**Charging Requirement:** Make sure to charge your scooter in conditions that do not exceed 104 degrees Fahrenheit or below 32 degrees Fahrenheit.



# Scooter Console Functions

- Long press power button **to power on and off.**
- Hold “+” button for 3 seconds to power the headlight and tail light **power on and off.**
- **To unlock the display lock** the password is 000. Use the “ + ” button to input 0 and press the power button to set. Repeat the process to enter in the full code 000. Once all three zero’s have been selected, press the power button twice to deactivate the lock.
- **To set your own code**, press the “ + ” button and the power button together for 10 seconds. Then use the “ + ” button to input the first number of your code and press the power button to set. Repeat the process to set your own individual three number code. Once your three number code is selected, press the power button twice to deactivate the lock.

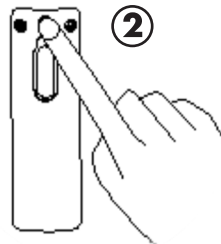
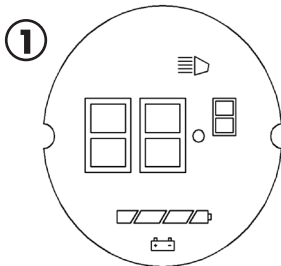

- Press the throttle for 8 seconds to activate Cruise Control while moving. Press the handbrake to cancel the cruise control feature.
- Hold the “ - ” button while walking next to the scooter to activate push assist mode. Once the push assist mode has been activated the scooter will move at 1.8 mph to make it easier to walk next to the scooter.
- The console on the Scooter displays speed in MPH, Distance, Battery life, and the Headlights.



# Riding Tips

1. You will want to start riding your scooter with one foot on the platform and one foot on the ground. Use your foot on the ground to push off and at the same time, press the throttle button to begin movement.
2. Press the brake handbrake to slow down or stop.
3. The scooters perform best when on a smooth surface e.g. car parks, smooth roads, footpaths, & bike lanes.
4. Always clean your scooter (wheels, platform..etc.), it's a machine and it needs to be maintained.
5. Do not press the throttle while walking with the scooter beside you.
6. Be aware of the terrain you are riding on, watch out for curbs and obstacles!



# Putting Your Scooter Away/Folding

Before folding the scooter, make sure that the scooter is powered off.

**Folding:** Ensure the electric scooter is powered off, press the lock buckle as the figure shows and pulled down the lever. Fold the tiller down towards the rear fender and lock the tiller hook to the fender hook buckle.

**Unfolding:** Unconnect the tiller hook from the fender hook. Once unhooked pull the tiller upwards and lock the locking device on the bottom of the tiller by pulling the clamp towards the tiller. Make sure to test the tiller before riding to make sure it is locked into place.

1



2

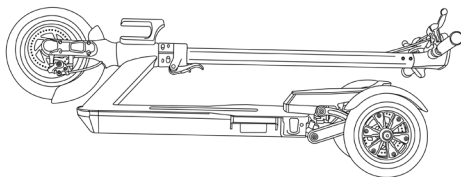

# Maintenance & Repair

**If you regularly clean and maintain your electric scooter, it will extend its life.**

**Cleaning and storage:** If the scooter is dirty, wipe it clean with a soft damp cloth.

**Brake Adjustments & Service:** If you notice you need brake adjustments or any service on your scooter, contact our customer service team and we will adjust and repair your scooter. Do not repair your scooter yourself, this can void your warranty and you risk damaging the scooter.

**Tires:** If you notice that the tire pressure is low, please fill to the recommended PSI on the side of the tire. **Recommended PSI: 50**

**DO NOT** use alcohol, gasoline, kerosene, or other corrosive chemical solvents to clean the scooter. It can severely damage the appearance and structure of the scooter. Please do not use a pressure washer as it may also cause damage to the electronics.

**Storage:** When you're not using your scooter store in a dry and cool location. Avoid storing your scooter outdoors because sun exposure can damage it's appearance and may cause wear on the life of the battery and tires.



# Battery Information

Only use the approved GOTRAX power adapter to charge your scooter, others may cause risk of fire & equipment may be damaged.

Improper disposal of used batteries may seriously pollute the environment. Please comply with local disposal regulations.

Make sure to store your scooter and power adapter in conditions that do not exceed 122 degrees Fahrenheit or below -4 degrees Fahrenheit.

**Warning** - Risk of Fire - No User Serviceable Parts, The prolonged exposure to UV Rays, Rain and the Elements may damage the enclosed materials, store indoors when not in use.



# Troubleshooting

We frequently update our user manuals at **GOTRAX.com**, and reserve the rights to update and change manuals online.

**Please contact our customer service team if you are experiencing problems or need more detailed information. They can be reached at GOTRAX.com**

# Warranty

For warranty information, please visit **GOTRAX.com**.



WWW.GOTRAX.COM

#RideGOTRAX





# **GOLABS, INC**

GOTRAX.com  
2201 Luna Rd.  
Carrollton, TX 75006