

GO TRAX

Honeycomb Tire Installation (Rear)

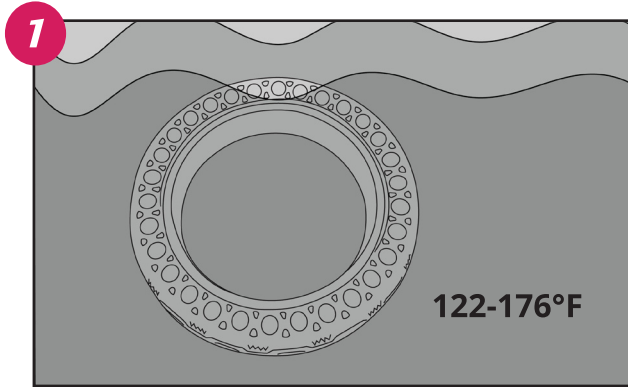

STEP 1: Soak tire in hot water for 5-10 minutes to make it softer and easier to install. Immerse tire completely.

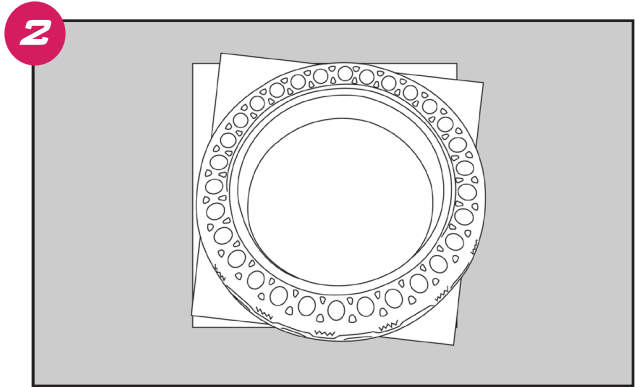

STEP 2: Set the honeycomb tire on a soft surface or on top of a folded towel to protect the rim and rotor from damage during installation.

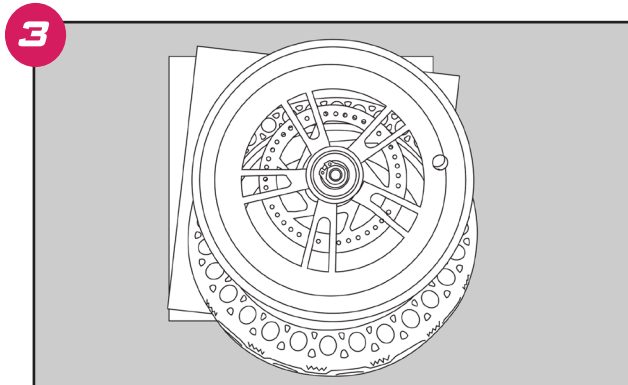

STEP 3: Angle the rim and press it onto one side of the honeycomb tire.

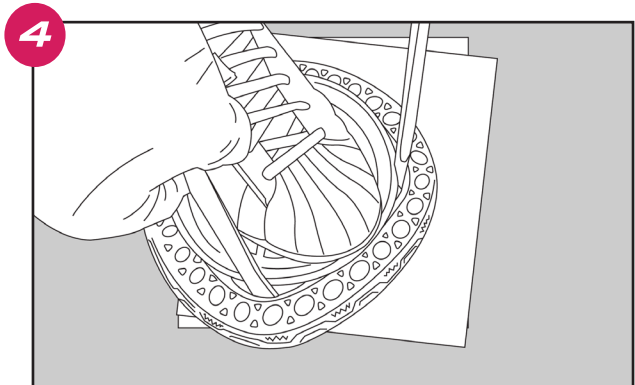

STEP 4: Apply pressure to the tire levers while pressing down with your foot. The tire will stretch around the rim with the proper amount of force.

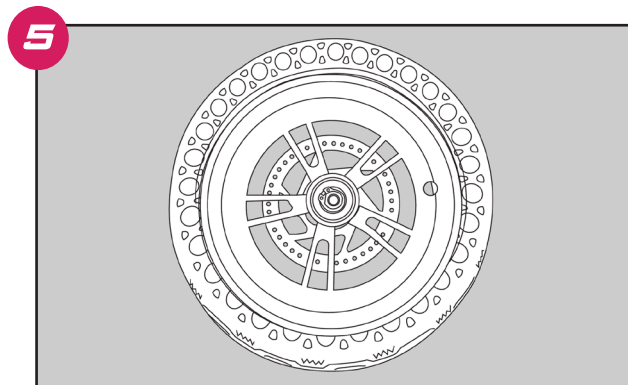

STEP 5: Once tire is stretched around the rim remove tire spoons. Using your hands you can massage the tire onto the rim to seat the bead correctly. Once bead is seated properly on the rim reinstall tire onto the scooter.