



**GOTRAX**

**G1  
USER MANUAL**

# CONGRATULATIONS ON YOUR PURCHASE!

This user manual will help you assemble and operate your new G1 Electric Scooter. Be sure to read **ALL OF THE INFORMATION** in this manual before riding.

**NOTE TO ALL RIDERS UNDER 18 YEARS OF AGE:** It's crucial that you get parental permission before riding your G1 Scooter.







## DON'T RIDE UNTIL YOU READ THIS:

 **ALWAYS** wear a helmet when riding your G1 Electric Scooter

 Make sure your scooter has a **full battery** before taking it out to ride.

 **Always** be aware of local road laws, and follow them.

 **Do not** ride the scooter under the influence of drugs or alcohol.

 **Do not** ride under wet conditions. The scooter may slide from under your feet causing injury. Wet conditions may damage the electronics and void the warranty.



## WARNING MESSAGE

1. **Avoid water** - The scooter is not waterproof. The electronics may be damaged due to water and water damage is not covered by our warranty. Riding in wet conditions is also very dangerous and may result in injury.
2. **Abuse** - We do not cover physical damage due to negligent care and extreme riding.
3. **Whenever you ride the Gotrax G1 scooter**, you risk severe injury or even death from loss of control, collisions, and falls. Use caution and ride at your own risk.
4. **Do not** modify the product from the manufacturers original design.
5. **Keep** hands and all body parts away from moving parts while operating the scooter.
6. **Before riding** - be sure to check the scooter over and make sure the scooter is operating correctly before each use.
7. **Before riding** - be sure to check that the braking system is functioning properly; also be sure to check that all safety labels are in place and you understand the safety warnings.
8. **Before riding** - be sure that any and all axle guards, chain guards, or other covers or guards supplied by the manufacturer are in place and in serviceable condition.
9. **Before riding** - be sure to check that the tires are in good condition, inflated properly, and have sufficient tread remaining.
10. **Never** exceed the 220 lb (100 kg) maximum load rating.
11. The G1 scooter should **never** be used by children under the age of 16.
12. **Maximum Speed** - Your G1 scooter goes the maximum speed of 16 mph.



# UNPACK

You should find each of these items in your G1 box:

1. G1 Scooter
2. G1 Approved Power Adapter / Charging Unit

①

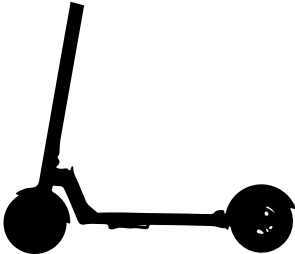

②

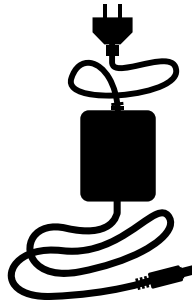

Remove all packing material, then inspect each item for any accidental damage that may have occurred during shipping.



# GET TO KNOW YOUR SCOOTER

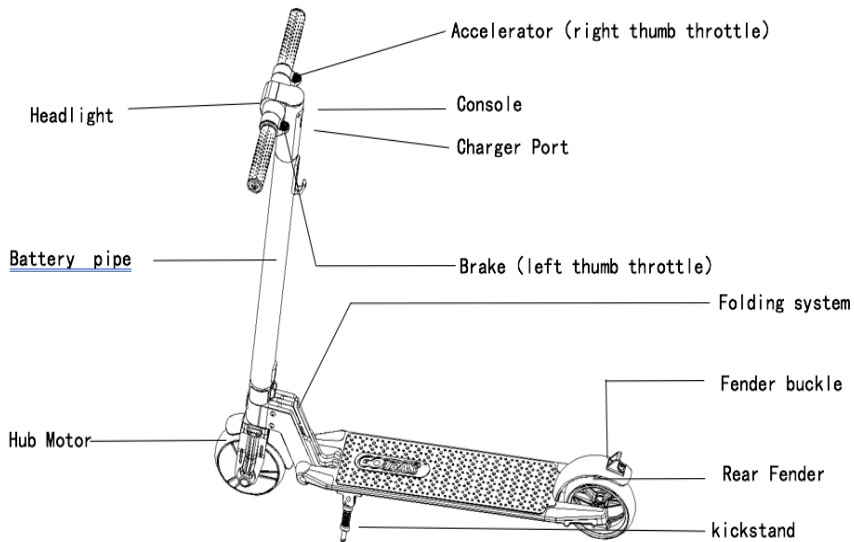

The G1 Scooter comes partially assembled.



# CHARGE THE SCOOTER

**Before using the scooter, you must fully charge the battery.**

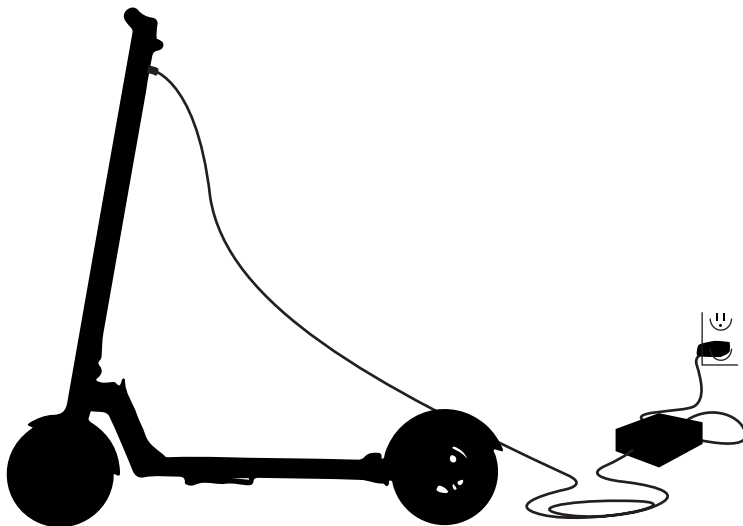

1. Open the rubber charging port cover.
2. Insert the charging plug into the port.
3. The charger box will have a green light when fully charged and a red light when charging.
4. When you are done charging be sure to cover the charging port to keep it clear of dust and debris.



# SCOOTER CONSOLE FUNCTIONS



To power the scooter on or off, press and hold the red button for 5 seconds.

To power the headlights on or off, press the red button quickly 3 times.

To change between 1st and 2nd gear, press the red button quickly 2 times. The display screen on the console will switch from one bar (1st gear) and 2 bars (2nd gear).

The console on the Scooter displays speed in MPH, Battery life, and what gear the scooter is currently in.



# RIDING TIPS

1. You will want to start riding your G1 with one foot on the platform and one foot on the ground. Use your foot on the ground to push off and at the same time, press the throttle button to begin movement.
2. Press the brake-throttle to slow down or stop. For quicker stopping step on the rear fender foot brake.
3. The scooters perform best when on a smooth surface e.g. car parks, smooth roads, footpaths, & bike lanes.
4. Always clean your scooter (wheels, platform.. etc.), it's a machine and it needs to be maintained.
5. Do not press the throttle while walking with the scooter besides you.
6. Be aware of the terrain you are riding on, watch out for curbs and obstacles!
7. Use the red button to change between gears as you would on a bike, cycle through them according to the terrain and elevation. First gear equals more torque for going uphill, second gear is more speed for straight aways.
8. **CAUTION** : The left paddle control on the console controls the motor's Electro-Magnetic brake. This brake is energized by the operation of the motor and will NOT be 100% effective until the motor has been in operation for 30 seconds.



## PUTTING YOUR SCOOTER AWAY / FOLDING

Before folding the scooter, make sure that the scooter is powered off.

Pull the Tiller towards the back wheel, as shown in the figures. Insert the hook on the tiller into the loop on the rear fender buckle. You may hear a click which indicates that you were successful in folding and locking the scooter.

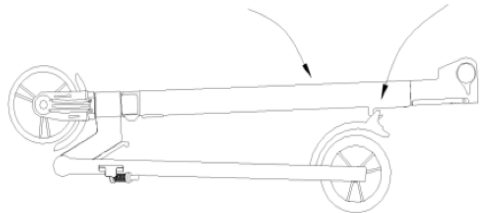



# MAINTENANCE AND REPAIR

If you regularly clean and maintain your electric scooter, it will extend its life.

**Cleaning and storage:** If the electric scooter surface is dirty, wipe it clean with a soft cloth.

**Brake adjustments & service:** if you notice you need brake adjustments or any service on your GXL scooter, contact our customer service team and we will adjust and repair your scooter. **Do not** repair your G1 yourself, this can void your warranty and you risk damaging the scooter.

**DO NOT** use alcohol, gasoline, kerosene, or other corrosive chemical solvents to clean the scooter. It can severely damage the appearance and structure of the scooter.

Please do not use a pressure washer as it may also cause damage to the electronics.

**Storage:** When you're not using your scooter store in a dry and cool location. Avoid storing your scooter outdoors because sun exposure can damage it's appearance and may cause wear on the life of the battery and tires.

**Tightening the Tiller:** If you notice that the tiller is loose or wiggles while riding, you can tighten the screws. Open the plastic cover, and use the Allen wrench to tighten the screws as shown in the figure to the right.



## **BATTERY INFORMATION**

Only use the approved Gotrax power adapter to charge your G1 scooter, others may cause risk of fire & equipment may be damaged.

Improper disposal of used batteries may seriously pollute the environment. Please comply with local disposal regulations.

Make sure to store your scooter and power adapter in conditions that do not exceed 122 degrees fahrenheit or below -4 degrees fahrenheit.

# TROUBLESHOOTING

We frequently update our user manuals at **gotrax.com**, and reserve the rights to update and change manuals online.

**Please contact our customer service team if you are experiencing problems or need more detailed information. They can be reached at [gotrax.com](https://gotrax.com)**

# WARRANTY

This scooter is covered by a 90-day manufacturer's warranty that covers defects in workmanship and material. This does not cover misuse, neglect, abuse, accident, or water damage. For warranty claims and details, please visit **gotrax.com**. Always keep your original shipping box in case the scooter needs to be returned or repaired.

**GOTRAX**

**WWW.GOTRAX.COM**

**#RIDEGOTRAX**



