



EVEREST



www.gotrax.com

WE'RE HERE TO HELP!

CONNECT WITH SUPPORT

Email: Support@gotrax.com

Phone: 1-844-446-8729

Hours: 9am - 5pm MST, Monday - Friday

GOTRAX
GOTRAX



⚠ WARNING

- Please read this manual carefully.
- This manual contains important safety information.
- Minors under the age of 16 are not allowed to drive this electric motorcycle.

Introduction

Congratulations on your decision to purchase Everest series electric motorcycle, which combines the technology and experience of Gotrax team component manufacturing and integrated electric drive for many years. You are now the owner of the state-of-the-art electric motorcycle, which with proper care, will bring you long time pleasure. This manual will comprehensively provide you with the basic characteristics and operating skills of this model. For more detailed information about EVEREST dirt bike, please visit www.gotrax.com.

Important safety information:

- This instruction manual contains important information, precautions, warnings and hazard notes for the use of the vehicle. The illustrations in the manual may differ slightly from the vehicle in detail, but the principles described are the same.
- Electric motorcycle has always maintained high-quality standards, due to the unremitting pursuit of product quality and the continuous in-depth research and improvement of product design. The information provided may not be the same as your vehicle information without further notice.
- For more detailed information about EVEREST dirt bike, please visit www.gotrax.com.

Owner's Manual



GO TRAX

Important Information

Failure to observe the contents of the manual may lead to serious injury or death!

This manual and its important information are marked as follows:



Safety warning signs mean attention, careful, vitally important

● Failure to comply with warning signs may cause fatal injury or death to Everest electric motorcycle drivers, bystanders, maintenance or maintenance personnel.

● Warning means that precautions should be taken to avoid damage to the vehicle.

Careful

Tips provide you with important information for easier operation.

Assembly:

Open the Carton:

1. Please check whether the outer packaging (as shown in the upper right picture) is complete; then shear the packing belt and remove the packing carton, as shown in the lower right picture.
2. Relax straps 6
3. Loosen front axle 1, locking nut, and then pull out the front axle
4. Remove the packaging bottom tray and lower the side stand

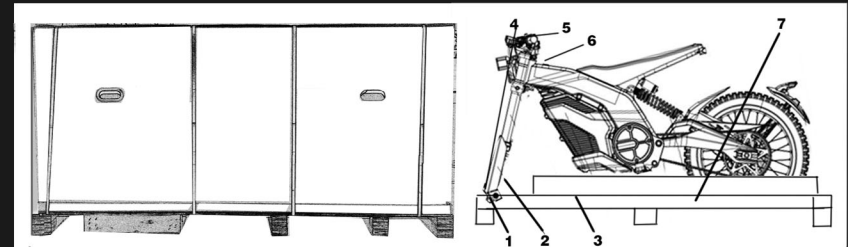

1. Front axle and lock nut
2. Front fender bracket
3. Accessory kit
4. Handle bar
5. Front turning signal
6. Front tightening straps
7. Front rim and tire



Assemble front wheel:

1. front axle
2. Front right shock absorber
3. front wheel installing bush
4. front rim assembly
5. Front brake disc
6. front hydraulic brake
7. front wheel speed sensor
8. front axle bolt
9. front left shock absorber

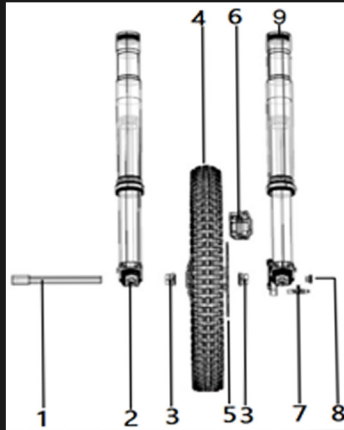

1. Prepare to assemble parts: front axle 1, front wheel bushing 3, and front axle bolt
2. Reassemble sequence as shown in the left diagram: Front axle 1 Pass through in sequence Front right shock absorber, Front wheel bushing 3, front rim assembly 4, front wheel bushing 3, front left shock absorber 9; Check that the front axle is in place, lock front axle bolt 8 after confirmation
3. Front brake 6 installation: remove the black fixed stop card of the pump under the hydraulic brake, then clip the brake 6 into the brake disc 5, squeeze the right brake handle, install the bolt tight and then release the brake handle.

5

Warning

Grease on the brake disc will reduce the braking effect, please always keep the brake disc grease free, please use detergent to clean the brake disc when necessary.

Assemble Handlebar

1. Handle bar
2. Handlebar seat
3. handle bar locking bolts 4-M6*20
4. Handle bar locking cover

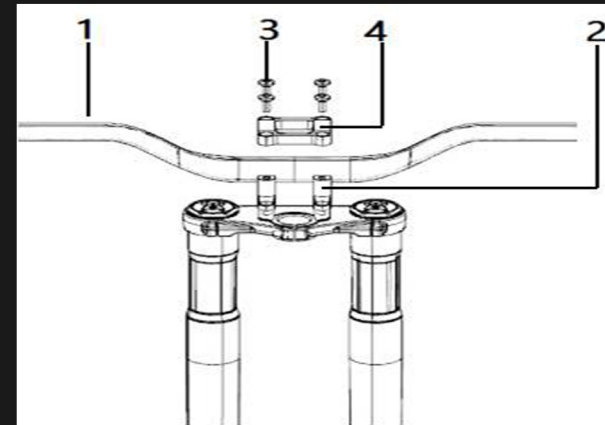

Handlebar fixing:

1. Put the handle bar 1 into the handle seat 2 slot and make sure that the scale on the handlebar is evenly distributed
2. Cover the handlebar locking cover 4, and evenly lock the 4 bolts without loosening

6

3. Speedometer and indicator light

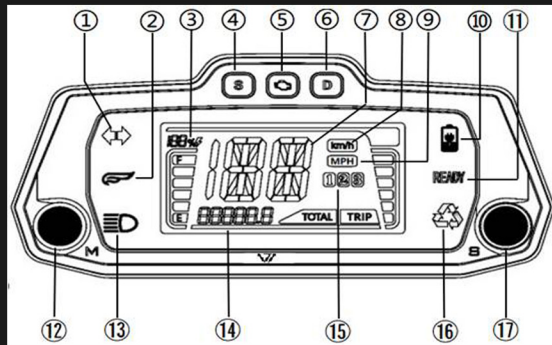

1. Turn indicator
2. Entertainment mode
3. SOC display
4. Power gear display
5. Fault display
6. Drive gear display
7. Speed display
8. Speed unit (km)
9. Speed unit (mile)
10. Charging warning light
11. Driving lamp
12. Function switch button
13. High beam indicator
14. Total ODO display/fault code display
15. Current drive gear
16. Energy Recovery
17. Function switch button

Tip: The meter of your F80 Electric Motorcycle may be slightly different from

Speedometer indicator

Press the remote control button of the steering lock controller, the LCD screen will light up

1. **High beam:** The meter is initially set into the daily running light, press the Light button on the left switch assembly of the left brake lever, and the high beam will be turned on.
2. **Left and right turn signals:** When the steering switch on the left brake lever switch assembly is pushed to the left, the left front and rear turn signals will flash; when the steering switch is pushed to the right, the right front and rear turn signals will flash.
3. **Entertainment mode display:** When it is on, there is no traction control (that is, no brake is powered off), and when it is off, there is traction control (that is, the brake is powered off).
4. **Sport gear:** When the S indicator flashes, Gear D is applied; when it is steady on, Gear 1 applied; when flashing slowly, Gear 2 applied; when flashing fast, Gear 3 applied.
5. **Drive gear:** Press the N/D button on the right brake lever to control the Gear D indicator to light up or off; ①. **Steady on:** Gear D is applied and the motorcycle can be driven; ②. **OFF:** Gear N is applied.
6. ①. **Keep the lights on to indicate that you are ready to drive ;** ②. **When the lights go out, it means you can't drive**

7、Energy Recovery indicator:

①. **Steady on:** the auxiliary brake is applied to recover the energy after a delay of 20 ms when the braking signal is detected (or the speed is reduced by 10%);

②. **Flashing:** the energy is recovered after the throttle is released;

③. **Off:** the energy recovery is disabled.

8、Charging warning light:

①. **Off:** sufficient power;

②. **Steady on:** warning for insufficient power;

③. **Flashing:** the battery is in low voltage and should be charged as soon as possible.

9、Function switch button - M button:

①. **Press it once:** switch the display of Trip and Total; the trip and maximum speed are displayed at the same time; the speedometer shows the current speed when the motorcycle is running;

②. **Press and hold it:** switch the mileage unit between km and mile;

10、**S button:** In Trip mode, press and hold the S button for more than 2 seconds, and the Trip and Max. Speed will be cleared zero synchronously.



Warning

If you find that the indicator light is on or flashing after the vehicle is powered on, you may not be able to drive normally if you continue to use the motorcycle; if you find that the indicator light is on or flashing while driving, please stop using the motorcycle immediately; lighting or flashing indicates that your motorcycle has broken down, please check the fault code displayed on the instrument according to the description in this manual, and consult the local GOTRAX authorized dealer as soon as possible.



Warning

Please do not flush the speedometer directly with high pressure water. Please do not wipe the speedometer with organic solvents such as gasoline and alcohol, otherwise it will cause partial cracks or discoloration of the meter.

Directional combination switch

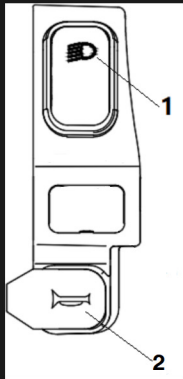

Left handlebar switch combination

1. Headlight switch button
2. Horn button

Right handlebar switch combination

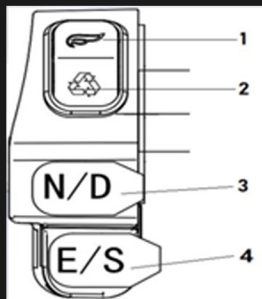

1. Entertainment mode switch
2. Energy recovery switch
3. Switch between gear and neutral
4. Gear switch button



Info: entertainment mode activation:

please press and hold the button for 3 seconds

Front and rear shock adjustment (Right and left shock)

Adjusting the preload of front and rear shock absorber is to adapt to different drivers, loads, driving mode and road environment, in order to achieve the best driving performance of the motorcycle, and avoid damage to the front fork, rear shock absorber and body.

Front left shock absorption (spring preload) :

1. Spring preload adjusting knob
2. Vent screw
3. 10mm wrench or sleeve

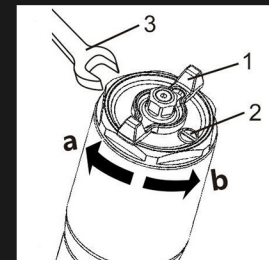

1. Rotate the adjusting knob in the direction of a to increase the spring preload value
2. Rotate the adjusting knob in the direction of b to reduce the spring preload value
3. The rotation of spring preload adjusting knob can be adjusted manually or by 10mm wrench or a socket
4. The adjustable height of spring preload is 12.5mm. The height of the spring preload adjustment knob can be raised and lowered by one turn of 1.25mm

Front right shock (return damping)

1. Return adjusting button
2. Bleed screw

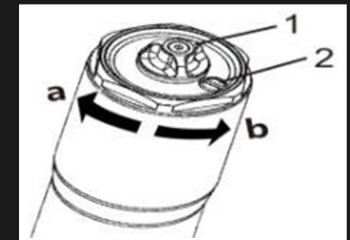

1. Rotate the recovery adjustment button in the direction of A to increase the recovery damping
2. Rotate the recovery knob in the direction OF B to reduce the recovery damping

Front and rear shock adjustment.

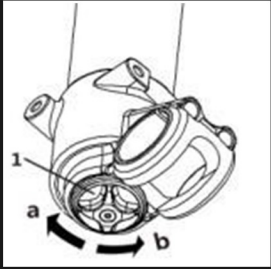

Compression adjustment button

1. Rotate the compression adjusting knob in the direction of a to increase the compression damping
2. Rotate the compression adjusting knob in the direction b to reduce the compression damping

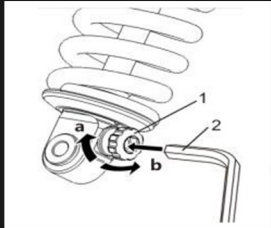

Return damping regulation

1. Return adjusting button
 2. 8mm inner hexagon wrench
- ①. Rotate the recovery adjustment button in the direction of a to increase the recovery damping
 - ②. Rotate the recovery knob in the direction of b to reduce the recovery damping
 - ③. the rotation of the adjustment button can be manually adjusted and 8mm inner hexagonal wrench two ways of adjustment.

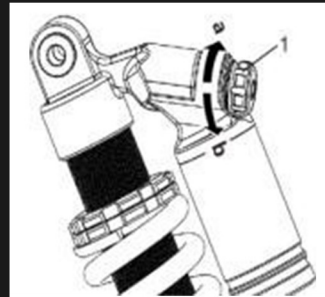

Compression damping regulation

1. compression adjustment button
- ①. Rotate the compression adjusting knob in the direction of A to increase the compression damping
 - ②. Rotate the compression adjusting knob in the direction B to reduce the compression damping

Front and rear shock adjustment (adjusted shock assembly)

Spring preload

1. Lock nut
 2. Spring preload adjusting nut
- ①. Rotate the adjusting nut in the direction of a to increase the spring preload value
 - ②. Rotate the adjusting nut in the direction b to reduce the spring preload value

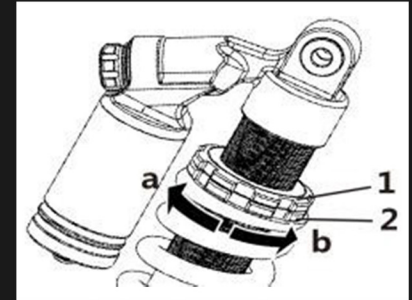

Spring preload

1. Special wrench

Locking torque of locking nut:
35 Nm

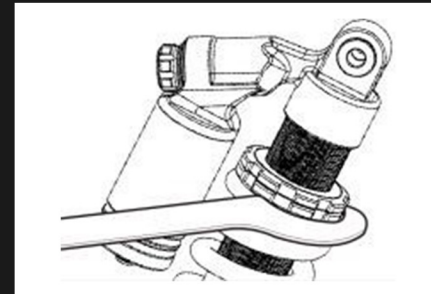

⚠ Warning:

Please adjust preload, recovery damping and compression damping appropriately according to riding needs; Please do not blindly adjust the preload of shock absorption, improper adjustment results will make you feel uncomfortable or weaken your ability to control the vehicle.

⚠ Note:

Special tools are required for preload of shock absorber springs after adjustment. If adjustment is required, please use your local CAOFEN authorized distributor to provide such services for you.

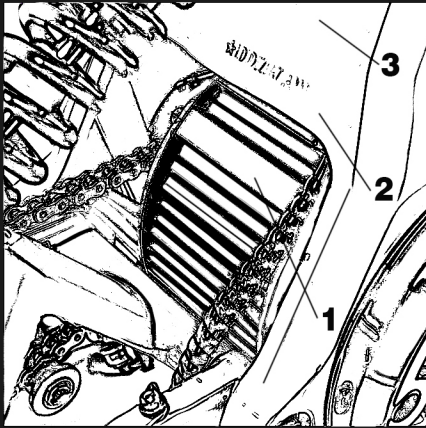

Vehicle identification

- 1、 Motor model and manufacturing code
- 2、 Vehicle identification number (VIN)
- 3、 Vehicle Nameplate

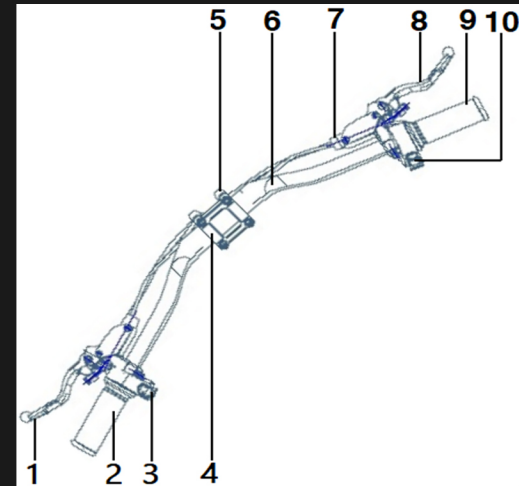

Front

- 1、 left brake lever
- 2、 left hand grip
- 3、 left switch assy
- 4、 handlebar lock cover
- 5、 handlebar base
- 6、 handle bar
- 7、 brake switch
- 8、 right brake lever
- 9、 right hand grip
- 10、 Right speed control switch

Left Side

- 11. Rear Fender bracket for off-road vehicle
- 12. Off-road rear fender
- 13. Seat
- 14. Frame
- 15. speedometer assy
- 16. Head light assy
- 17. Horn

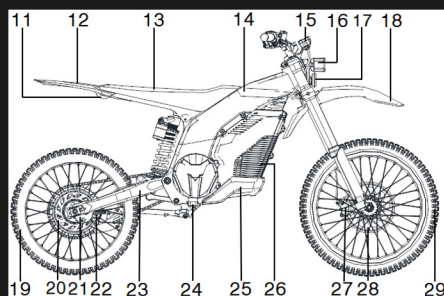

- 18. Offroad front mud guard
- 19. Rear inner tyre
- 20. Brake disc
- 21. rear brake fixing bracket
- 22. rear hydraulic brake
- 23. fork assembly
- 24. Front right pedal assembly
- 25. Battery bottom protective cover
- 26. lithium battery pack
- 27. front hydraulic brake
- 28. Front brake disc
- 29. front outer tyre

Right Side

- 30. Front shock absorber
- 31. rear shock absorber assy
- 32. front rim assembly
- 33. Front fork decorative cover
- 34. Frame trim cover
- 35. side stand
- 36. Rocker connecting arm
- 37. the Rear rim assembly

Frame inside

- 38. Controller
- 39. Alarm controller
- 40. DCDC converter
- 41. Motor

Operation and driving of GOTRAX electric motorcycle Steps to start the vehicle:

1. Turn on the battery switch, and the power switch indicator light is on.
2. press the alarm switch. The speedometer lights up and the vehicle enters the self-test state.
3. Stow the side bracket, and when the READY light on the instrument comes on, it means that you can ride normally.
4. Press the N/D button on the right brake handle to enter motion D gear, and the speedometer D gear light will light up.
5. Turn the right speed control handle to drive normally.

Warning

When the outdoor temperature is below 0°C, the low temperature protection of the battery system may be triggered. Please charge the battery before using it; otherwise, the vehicle may not run normally. When the meter appears Fault code, please check the fault code displayed on the meter according to the description in this manual, and consult the local GOTRAX dealer for treatment as soon as possible.

Dangerous

When the speedometer shows D, at this time the vehicle is in the forward state, turn the right speed control turn the vehicle will run, not familiar with the vehicle operation process if the rotation speed control turn is very large, the vehicle will suddenly move forward at high speed, may lead to personnel injury or vehicle damage; Therefore, when refueling for the first time, please be sure to concentrate on the smooth and light rotation of the speed control, and the left and right index finger and middle finger are placed on the brake handle to prevent the speed control rotation is too large and the vehicle can suddenly brake at high speed

Steps to turn off the vehicle:

1. After the vehicle stops, press the N/D button on the right brake handle, and the speedometer shows that the D light goes out and enters neutral, and the vehicle no longer walk.
2. The braced side bracket is in parking state, and the READY light is off.
3. Press the alarm button to power off and turn off all electrical equipment
4. Turn off the battery switch.

Warning

When the speedometer lights up, it may be impossible to directly power off the alarm key, so we can directly turn off the battery switch. In this case, please check the fault code displayed on the instrument according to the description in this manual, and consult the local GOTRAX dealer for treatment as soon as possible. The temperature of the motor may be very high after the vehicle is stopped, please cool it before touching it.

Dangerous

The failure of the speed control knob will make the switch difficult to operate. If you want to speed up or slow down, but it is difficult to use, it may cause serious injury or death. Please check the switch handle operation before starting, if the operation is not smooth or stuck, check the reason before riding. Such as unable to solve the problem. Please consult your local GOTRAX distributor.

Dangerous

Deceleration in the process of high-speed driving, such as just use the front brake or rear brake, the vehicle is easy to skid and out of control. Both front and rear brakes must be used equally.

Driving Precautions

1. No driving with passengers or animals.
2. In order to reduce the impact on the center of gravity of the motorcycle, all luggage on the motorcycle must be as low as possible; the weight of the luggage must also be evenly distributed on both sides of the motorcycle. Luggage protruding too far behind the motorcycle should be avoided.
3. The luggage must be securely fixed on the motorcycle. Please make sure that the luggage cannot be moved before driving. When the motorcycle feels unstable while driving, the firmness of the luggage should be rechecked and readjusted if necessary.
4. Do not carry heavy or bulky luggage. Overloading must affect handling and dynamic performance.
5. Do not install accessories that reduce the performance of this electric motorcycle and carry luggage that reduces the performance of the motorcycle, make sure that everything you do will not affect any lighting system, ground clearance, braking performance, roll angle, handling performance, tires Compression stroke, front reduction working stroke or other related driving performance of this electric motorcycle.
6. The increased weight on the handlebar or front fork will affect the steering performance and cause unsafe driving factors.

7. This vehicle cannot be converted into a three-wheeled motorcycle, and cannot be used for towing trailers or other vehicles. We will not be responsible for any damage or injury caused by the user's self-fitting of this vehicle.

8. It is forbidden to drive after taking medicine or drinking. Please wear suitable and genuine safety equipment: helmet, eye mask, face shield, gloves, boots, long-sleeved shirt or jacket, trousers.

Maximum load: no more than 100kg including driver, luggage and accessories).

Note: The speedometer shows that the 1st gear is the lowest power output, and the starting is the most stable, and the 2nd and 3rd gears increase the power step by step;

When the charging light is flashing and the power indicator is lower than 20%, please recharge it; the battery power protection strategy will limit the output power at 15%.

Charger Instructions

1. Overview

This smart charger is specially used to charge the power battery of GOTRAX vehicles. It uses a civil 10A or 16A socket power supply. The charging process is controlled by the charging program itself, and it stops automatically when it is fully charged.

2. Product appearance diagram

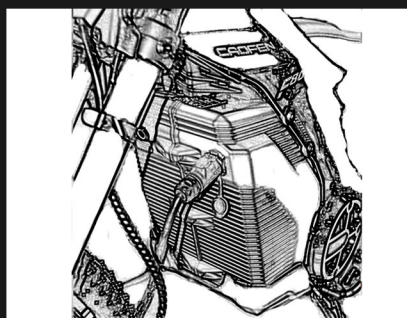
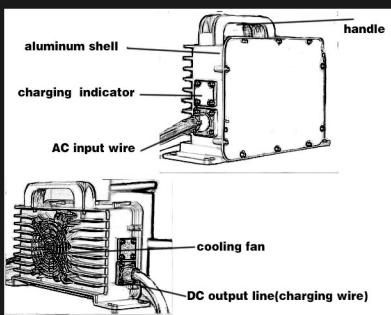

Product Features

| | |
|--|---|
| small size and high power | The charging speed is fast, and it can be charged to 80% of the power in two hours at 20 °C; |
| automotive grade shock resistance | durable; |
| six items security protections | Dedicated protection, over temperature protection, output short circuit, output reverse connection, output over-voltage, output over-current protection |
| IP66 level protection | Higher protection, higher security, higher reliability; |
| CAN intelligent communication | Real-time communication with the vehicle to ensure controlled charging; |
| wide temperature range operating temperature | It can work normally at -40 ~ 60 °C; |
| lightweight and portable design | All aluminum alloy die-casting shell, light weight and good heat dissipation. |

Environment and power requirements

| NO. | item | technical indicators | note |
|-----|-----------------------|----------------------|------|
| 1 | operating temperature | -40C ~+60C | |
| 2 | Storage temperature | -40C ~+90C | |
| 3 | relative humidity | 5%~95strong | |
| 4 | protection class | IP66 | |

| | | | |
|---|-------------------------------|--------------------|--|
| 5 | cooling method | forced air cooling | |
| 6 | Input voltage Input frequency | AC220V+15% | Pay attention to AC power matching. |
| 7 | | AC90—140V | AC 220v power supply is strictly prohibited. |
| | | 50Hz ± 2% | |

AC220V or 110v AC power supply should be selected according to the AC power supply (AC) voltage requirements indicated on the label at the bottom of the charger body, and the rated current of the corresponding charging socket should meet at least 10A (AC).

It is strictly forbidden to use AC220V power supply for AC110V (100V) special charger! Otherwise, there may be serious security risks.

Charging method

5.1 It should be charged in a cool, dry and ventilated place;

5.2 When charging, the charger should be kept away from flammable materials, keep good ventilation and heat dissipation around the charger, and it is strictly forbidden to cover things on the charger;

5.3 Press the battery switch to turn on the battery (the switch light is on);

5.4 Hold the DC output plug of the charger, insert it into the battery charging base, and push the lock in to ensure that the charging head and the battery charging base are fully and tightly connected;

5.5 Insert the AC input line plug of the charger into the appropriate socket (make sure the plug and socket are fully, fully and reliably inserted), the charging indicator of the charger will turn green, about 3S, the indicator will change from steady green to flashing red, and then The charger fan will automatically turn on and enter the charging state;

5.6 When the battery is fully charged, the charger will automatically stop charging. At this time, the indicator light of the charger will turn solid green and the cooling fan will stop rotating. On the corresponding instrument of the vehicle, the battery level is displayed as 100%, and the flashing battery charging symbol disappears.

5.7 After charging, unplug the charger output plug from the battery and cover with a dustproof plastic cover.

Then, remove the charger input plug from the AC outlet.

Frequently Asked Questions and Instructions

| NO. | Phenomenon | Problem | Solution |
|-----|---|---|---|
| 1 | charger, green light, not charging. | The AC power voltage does not match the input AC voltage indicated on the label of the charger. | Replace with an AC outlet that matches the voltage. |
| 2 | | The charger output plug is not inserted into the battery or is not fully inserted. | Fully insert the charger output (DC) plug into the battery charging socket. |
| 3 | | Battery switch not turned on | Press the switch, turn on the battery, and the switch light will turn on. |
| 4 | | The charger does not match the battery. | Contact the dealer or factory for replacement. |
| 5 | | The charger or battery temperature is too high. | It will be released naturally after the temperature is lowered to within 45°C |
| 6 | charging is slow | Temperature below 5 °C | It Change to an environment above 15°C for charging or wait for the battery temperature to rise, the charger will speed up by itself. |
| 7 | | The battery temperature is higher than 45°C | It will automatically speed up when the battery temperature drops. |
| 8 | | Charger parent is running out of battery | Check the AC outlet. |
| 9 | No response from the charger, indicating that the light is not on | The charger itself is faulty | Contact the seller or manufacturer. |

Indicator status description

| | | | |
|---|---------------------|---|----------------------|
| 1 | charging process | the red light flashes once every 1S | battery is below 90% |
| 2 | | the green light flashes once every 1S. | battery 90%~100% |
| 3 | | green light, always on. | charging finished |
| 4 | trouble instruction | the red light flashes once every 3S. | battery failure |
| 5 | | the green light flashes once every 3S. | charger failure |
| 6 | | the red and green lights flash alternately. | Input failure |

Safety precautions

- > Ensure that the charger vent and the space where it is located are kept unobstructed to prevent the charger from overheating.
- > When charging, keep away from heat sources and flammable materials, and charge in a cool, dry and ventilated place.
- > Ensure that the AC power supply voltage and current are consistent with the allowable input voltage and current of the charger.
- > For the sake of safety and electromagnetic compatibility, the three-pin plug of the charger needs to use a socket with a grounding wire.
- > The AC power supply line should not be too long or too thin, so as not to affect the normal charging of the charger.
- > The charger should be placed on a level surface, and the radiator should be kept vertical to ensure good heat dissipation.
- > If the charger is found to be abnormal or damaged during the charging process, please unplug the power plug and charger interface immediately, and contact the supplier.
- > It is strictly forbidden to disassemble the charger by yourself, and there is a danger of electric shock if you open the cover of the charger at will.

- > Ensure that the charger vent and the space where it is
- > Prevent damage to the charger wiring harness. If the wiring harness is found to be worn or damaged, please replace it immediately.
- > It is recommended that users perform dust removal treatment on the charger shell at least half a year.
- > The power input end of the charger must be equipped with over-current protection devices (such as fuses, AC circuit breakers).