

STAMINA[®] 1130

Magnetic Rowing Machine

Owner's Manual

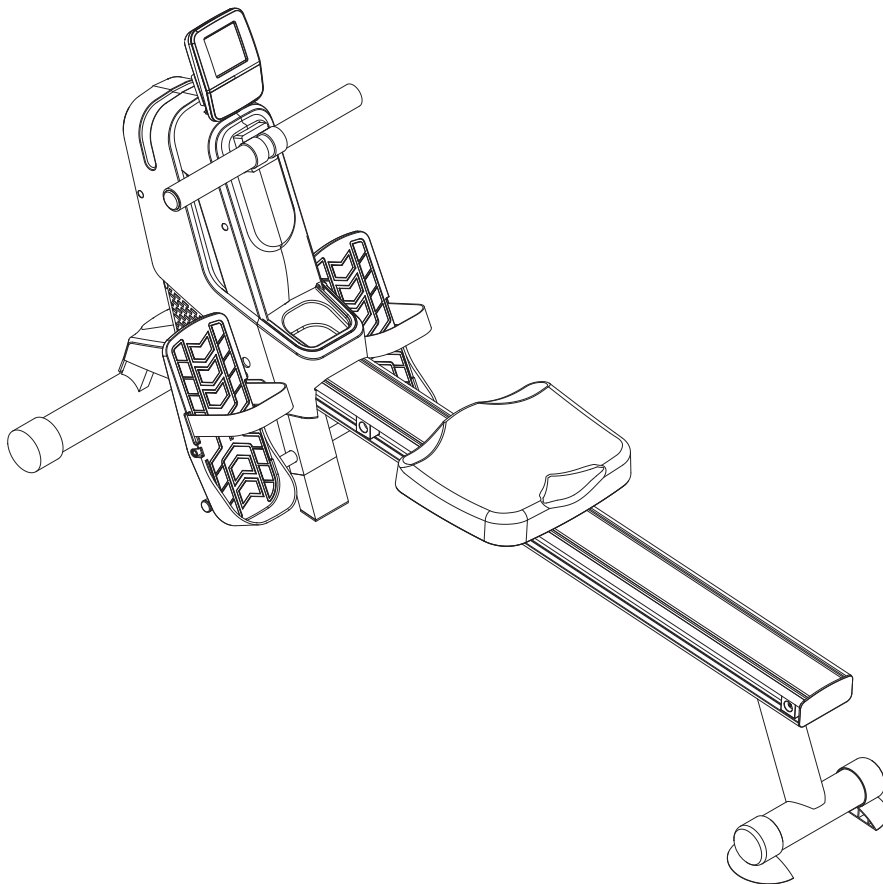

Product May Vary Slightly From Pictured.

CAUTION:

Weight on this product should not exceed 250 lbs.

▲ WARNING

Exercise can present a health risk. Consult a physician before beginning any exercise program with this equipment. If you feel faint or dizzy, immediately discontinue use of this equipment. Serious bodily injury can occur if this equipment is not assembled and used correctly. Serious bodily injury can also occur if all instructions are not followed. Keep others and pets away from equipment when in use. Always make sure all bolts and nuts are securely tightened prior to each use. Follow all safety instructions in this manual.

When calling for parts or service, please specify the following number:

Model#: 35-1130A

This Product is Distributed Exclusively by



2040 N. Alliance, Springfield, MO 65803

Customer Care

1 (800) 375-7520

www.staminaproducts.com

**STAMINA PRODUCTS
MADE IN TAIWAN**

© 2016 Stamina Products, Inc.
2016, 11

TABLE OF CONTENTS

Safety Instructions	2	Maintenance	19
Before You Begin	4	Conditioning Guidelines	20
Equipment Warning, Caution & Notice Labels ...	5	Warm-Up and Cool-Down	21
Hardware Identification Chart	6	Product Parts Drawing	22
Assembly Instructions	7	Parts List	23
Operational Instructions	11	Warranty	25
Computer Instructions	13	Notes	26
Storage	19	Fax/Mail Ordering Form	27

SAFETY INSTRUCTIONS

⚠ WARNING This product contains a chemical known to the State of California to cause cancer and birth defects or other reproductive harm.

⚠ CAUTION Consult your physician before starting this or any exercise program. This is especially important if you are over the age of 35, have never exercised before, are pregnant, or suffer from any health problem. This product is for home use only. Do not use in institutional or commercial applications. Failure to follow all warnings and instructions could result in bodily injury and property damage.

⚠ WARNING To reduce the risk of serious injury, read the following Safety Instructions before using the Stamina® 1130 Magnetic Rowing Machine.

1. Save these instructions and ensure that other exercisers read this manual prior to using the **Stamina® 1130 Magnetic Rowing Machine** for the first time.
2. Read all warnings and cautions posted on the **Stamina® 1130 Magnetic Rowing Machine**.
3. The **Stamina® 1130 Magnetic Rowing Machine** should only be used after a thorough review of the Owner's Manual.
4. We recommend that two people be available for assembly of this product.
5. Keep children away from the **Stamina® 1130 Magnetic Rowing Machine**. Do not allow children to use or play on the **Stamina® 1130 Magnetic Rowing Machine**. Keep children and pets away from the **Stamina® 1130 Magnetic Rowing Machine** when it is in use.
6. It is recommended that you place this exercise equipment on an equipment mat.
7. Set up and operate the **Stamina® 1130 Magnetic Rowing Machine** on a solid level surface. Do not position the **Stamina® 1130 Magnetic Rowing Machine** on loose rugs or uneven surfaces.
8. Make sure that adequate space is available for access to and around the **Stamina® 1130 Magnetic Rowing Machine**.
9. Before using, inspect the **Stamina® 1130 Magnetic Rowing Machine** for worn or loose components, and securely tighten or replace any worn or loose components prior to use.
10. Before using, check the condition of the STRAP(25). Replace the STRAP(25) if it is cracked or broken.
11. Consult a physician prior to commencing an exercise program and follow his/her recommendations in developing your fitness program. If at any time during exercise you feel faint, dizzy, or experience pain, stop and consult your physician.
12. Always choose the workout which best fits your physical strength and flexibility level. Know your limits and train within them. Always use common sense when exercising.
13. Do not wear loose or dangling clothing while using the **Stamina® 1130 Magnetic Rowing Machine**.
14. Never exercise in bare feet or socks; always wear proper footwear such as running, walking, or cross training shoes that fit well, provide foot support, and feature non-skid rubber soles.
15. Be careful to maintain your balance while using, mounting, dismounting, or assembling the **Stamina® 1130 Magnetic Rowing Machine**, loss of balance may result in a fall and bodily injury.
16. Do not use the SEAT(21) to move the **Stamina® 1130 Magnetic Rowing Machine**. The SEAT(21) will move and the SEAT CARRIAGE(10) may pinch your hand or fingers. When folding or unfolding the unit, keep all children away and make sure your hands are clear of any folding or pinch point.
17. The **Stamina® 1130 Magnetic Rowing Machine** should not be used by persons weighing over 250 pounds.
18. The **Stamina® 1130 Magnetic Rowing Machine** should be used by only one person at a time.
19. The **Stamina® 1130 Magnetic Rowing Machine** is for consumer use only. It is not for use in public or semipublic facilities.



NEED HELP?
CONTACT US FIRST
1 (800) 375-7520
customer.care@staminaproducts.com

Hi! From all of us here at Stamina Products, thank you for your purchase. We know that you have big fitness goals in mind and we are here to help you along. Call us, email us, or send us a message on Facebook. Be sure to contact us if you have any questions on your new product. We look forward to hearing from you!

With your body in mind,
Stamina Customer Care

To enact your warranty and to help us better serve you,
please **go online** and register your new product.

register.staminaproducts.com

It is quick and easy to register online, but if you're a little old school or just need a reason to raise that little flag on your mailbox, fill out the info on the last page of this manual and mail it in.



ONLINE

customer.care@staminaproducts.com
www.staminaproducts.com



TELEPHONE

1 (800) 375-7520



FAX

(417) 889-8064



MAIL

Stamina Products, Inc.
ATTN: Customer Care
P.O. Box 1071
Springfield, MO 65801-1071

 facebook.com/StaminaProducts
facebook.com/AeroPilates

CUSTOMER CARE HOURS:
Monday-Thursday, 7:30 AM-5:00 PM, Central Time
Friday, 8:00 AM-3:00 PM, Central Time

BEFORE YOU BEGIN

Thank you for choosing the **Stamina® 1130 Magnetic Rowing Machine**. We take great pride in producing this quality product and hope it will provide many hours of quality exercise to make you feel better, look better, and enjoy life to its fullest.

It's a proven fact that a regular exercise program can improve your physical and mental health. Too often, our busy lifestyles limit our time and opportunity to exercise. The **Stamina® 1130 Magnetic Rowing Machine** provides a convenient and simple method to begin your journey of getting your body in shape and achieving a happier and healthier lifestyle.

Before reading further, please review the drawing below and familiarize yourself with the parts that are labeled.

Read this manual carefully before using the **Stamina® 1130 Magnetic Rowing Machine**.

Although Stamina constructs its products with the finest materials and uses the highest standards of manufacturing and quality control, there can sometimes be missing parts or incorrectly sized parts. If you have any questions or problems with the parts included with your **Stamina® 1130 Magnetic Rowing Machine**, please do not return the product. Contact us FIRST!

If a part is missing or defective, please go to staminaproducts.com under the Customer Care section and order the part needed, or call us toll free at 1-800-375-7520 (in the U.S.). Our Customer Care Staff is available to assist you from 7:30 A.M. to 5:00 P.M. (Central Time) Monday through Thursday and 8:00 A.M. to 3:00 P.M. (Central Time) on Friday.

Be sure to have the name and model number of the product available when you contact us.

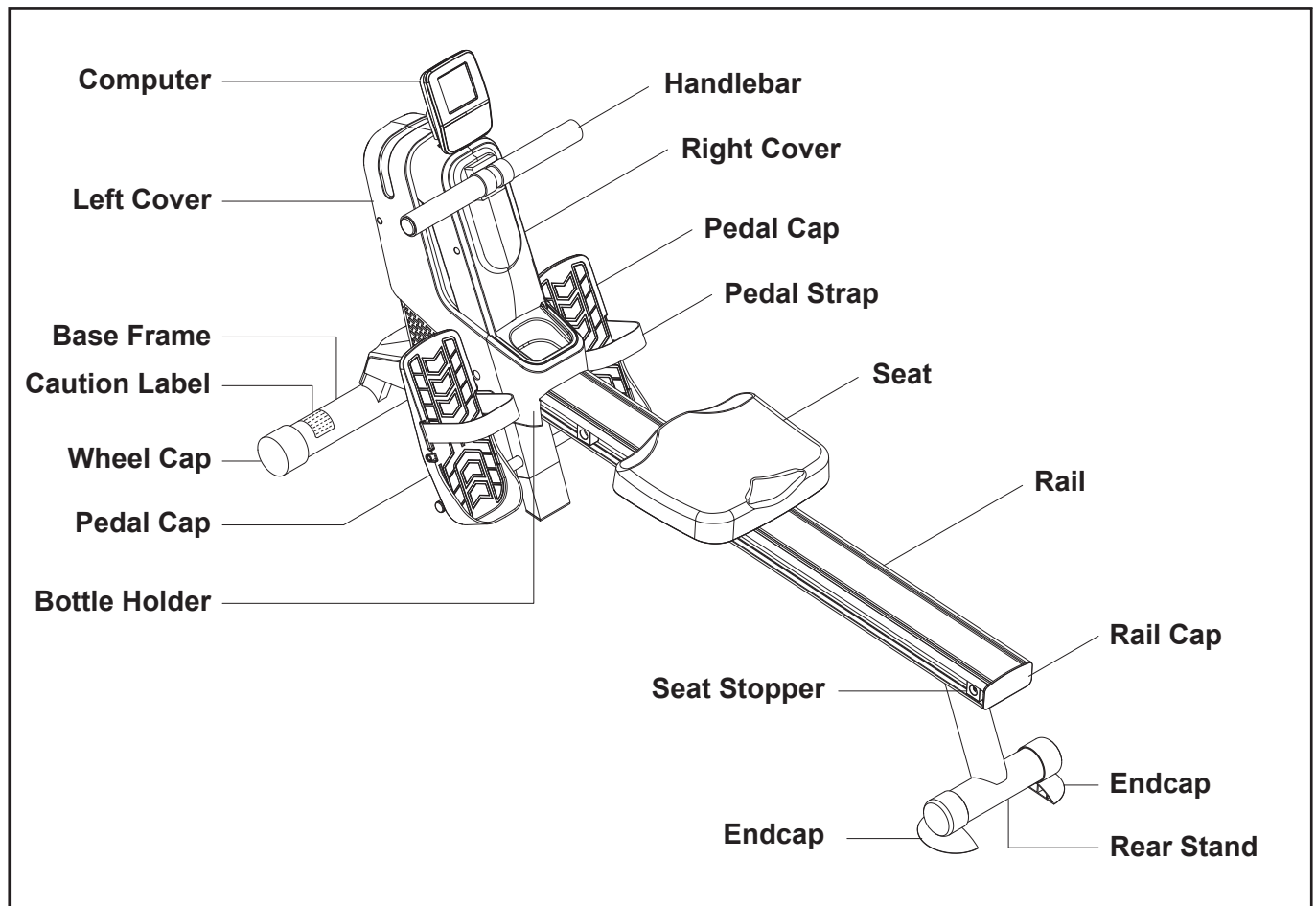

THE FOLLOWING TOOLS ARE INCLUDED FOR ASSEMBLY :



EQUIPMENT WARNING, CAUTION & NOTICE LABELS

This chart is provided to help identify the warning, caution, and notice labels on the **Stamina® 1130 Magnetic Rowing Machine**. Please take a moment to familiarize yourself with all of the warning, caution, and notice labels.

Label is larger than actual size

C1 CAUTION LABEL(109)



HARDWARE IDENTIFICATION CHART

This chart is provided to help identify the fasteners used in the assembly process. Place the washers or the ends of the bolts or screws on the circles to check for the correct diameter. Use the small scale to check the length of the bolts and screws.

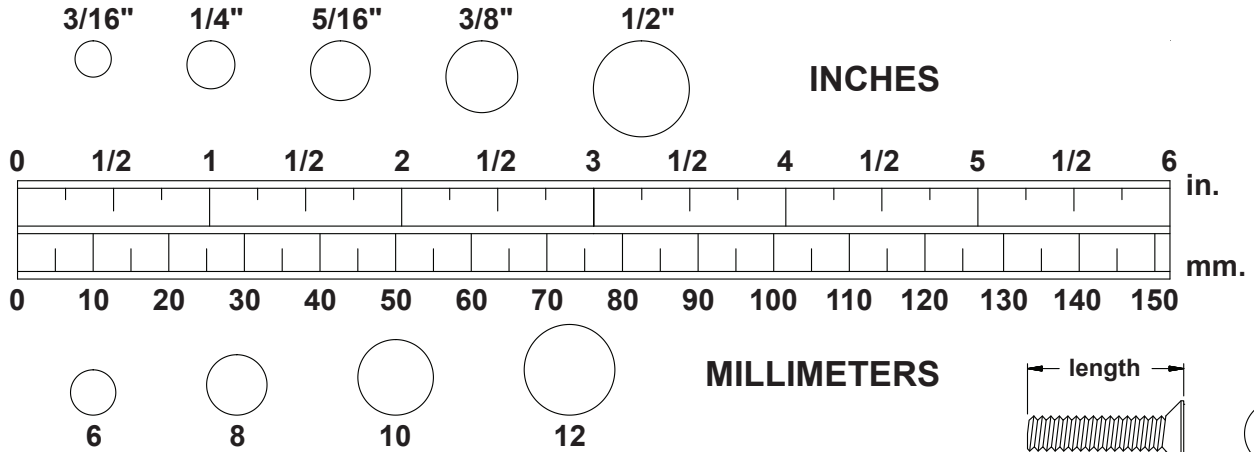

NOTICE: The length of all bolts and screws, except those with flat heads, is measured from below the head to the end of the bolt or screw. Flat head bolts and screws are measured from the top of the head to the end of the bolt or screw.

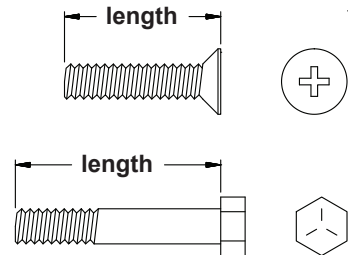

After unpacking the unit, open the hardware bag and make sure that you have all the following fasteners. Some fasteners may be already attached to the parts.

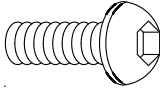
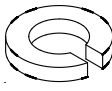
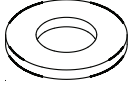
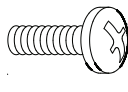
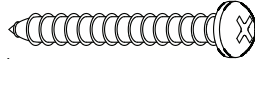
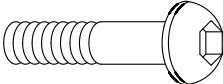
	Part Number and Description	Qty
	60 Bolt, Button Head (M8 x 1.25 x 15mm)	6
	85 Bolt, Button Head (M8 x 1.25 x 20mm)	2
	61 Lock Washer (M8)	4
	62 Washer (M8)	8
	64 Washer (M6)	5
	83 Large Washer (M8)	2
	63 Bolt, Round Head (M6 x 1 x 15mm)	5
	81 Screw, Round Head (M4.2 x 1 x 45mm)	1
	84 Bolt, Button Head (M8 x 1.25 x 40mm)	2

ASSEMBLY INSTRUCTIONS

Place all parts from the box in a cleared area and position them on the floor in front of you. Remove all packing materials from your area and place them back into the box. Do not dispose of the packing materials until assembly is completed. Read each step carefully before beginning. If you are missing a part, please go to staminaproducts.com under the Customer Care section and order the part needed, e-mail us at customer.care@staminaproducts.com, or call us toll free at 1-800-375-7520 (in the U.S.). Our Customer Care Staff is available to assist you from 7:30 A.M. to 5:00 P.M. (Central Time) Monday through Thursday and 8:00 A.M. to 3:00 P.M. (Central Time) on Friday.

STEP 1

Position the main assembly of the **Stamina® 1130 Magnetic Rowing Machine** as shown in illustration A. Attach the **BASE FRAME(3)** to the **MAIN FRAME(1)** with **BUTTON HEAD BOLTS(M8x1.25x40mm)(84)** and **WASHERS(M8)(62)**. Insert the **REAR SUPPORT(5)** into the **BASE FRAME(3)** and secure with **BUTTON HEAD BOLTS(M6x1x15mm)(63)** and **WASHERS(M6)(64)**.

STEP 2

Refer to illustration B. Turn the main assembly of the **Stamina® 1130 Magnetic Rowing Machine** upside down. Attach the **REAR STAND(2)** to the **RAIL(48)** with **BUTTON HEAD BOLTS(M8x1.25x15mm)(60)**, **LOCK WASHERS(M8)(61)**, and **WASHERS(M8)(62)**.

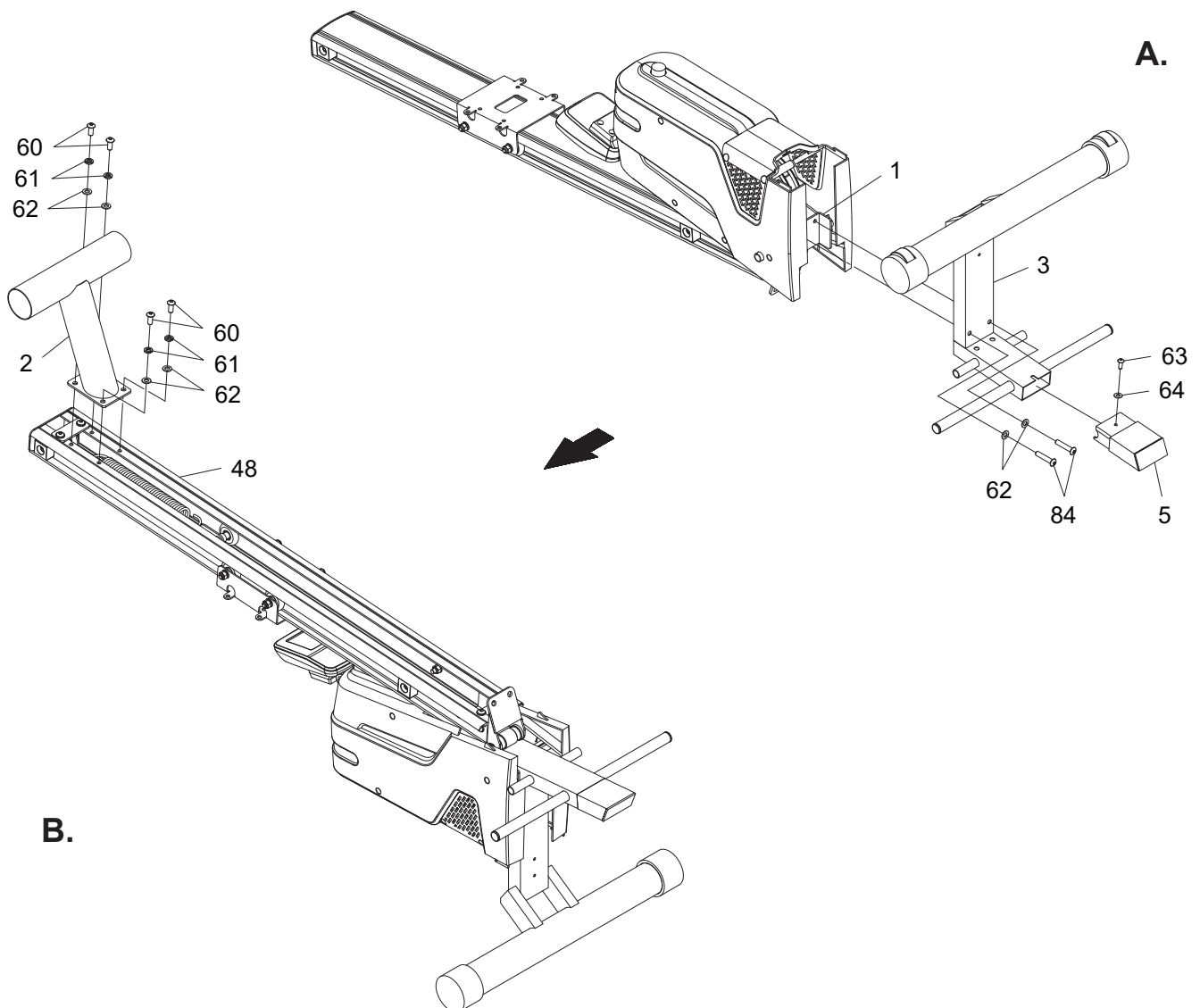

ASSEMBLY INSTRUCTIONS

STEP 3

Refer to the illustration below. Unfold the **RAIL(48)**, and then attach to the **BASE FRAME(3)** with **BUTTON HEAD BOLTS(M8x1.25x20mm)(85)** and **WASHERS(M8)(62)**.

STEP 4

Slide the **FRONT COVER(28)** onto the **LEFT** and **RIGHT COVERS(17, 18)**, then attach to the **BASE FRAME(3)** with **ROUND HEAD SCREW(M4.2 x 45mm)(81)**.

STEP 5

Attach the **SEAT(21)** to the **SEAT CARRIAGE(10)** with **ROUND HEAD BOLTS(M6x1x15mm)(63)** and **WASHERS(M6)(64)**.

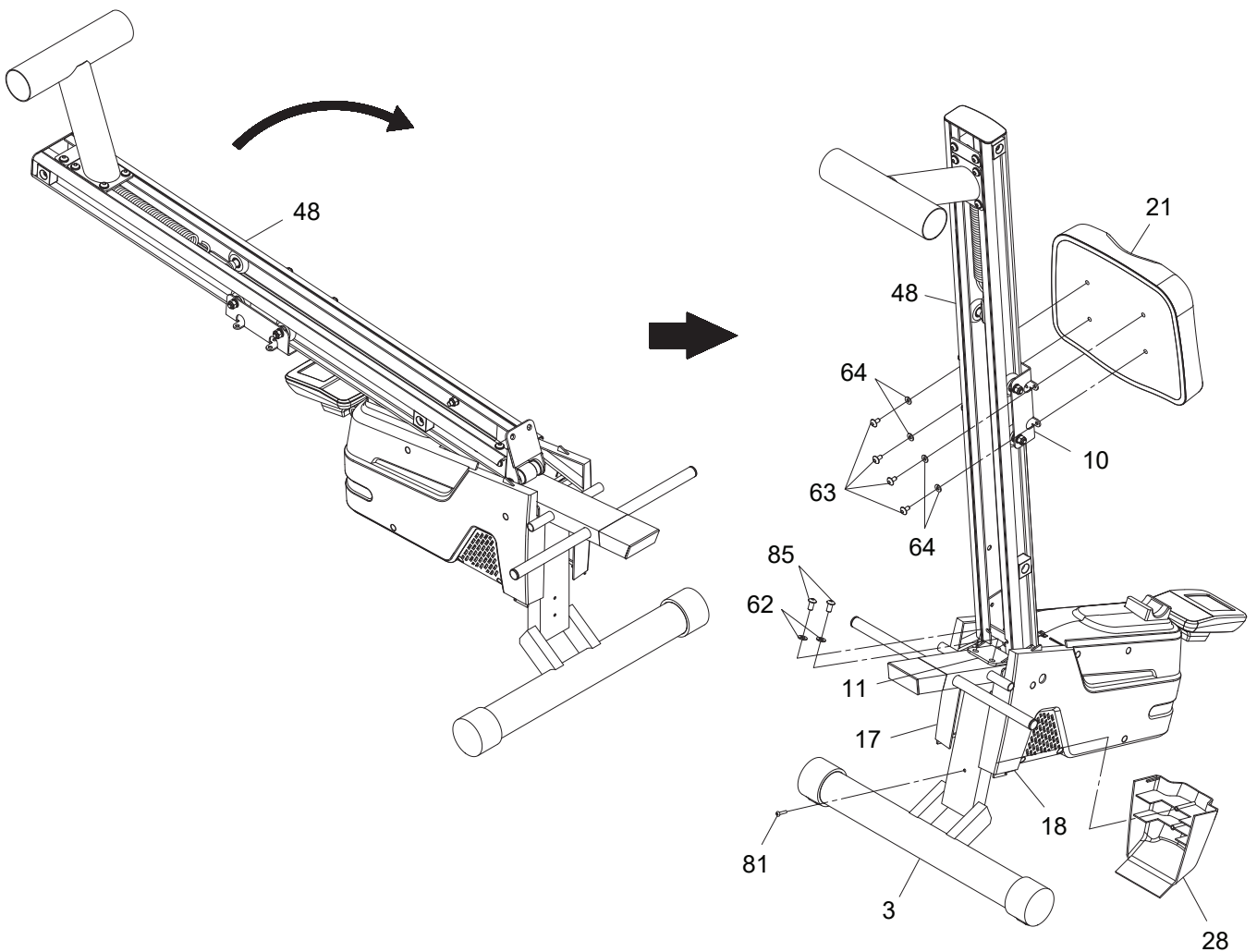

ASSEMBLY INSTRUCTIONS

STEP 6

Refer to detail view C. Insert the **HANDLEBAR(15)** through the **HANDLEBAR SLEEVE(111)**. Slide the **FOAM GRIP(22)** onto the protruding end of the **HANDLEBAR(15)**. Press the **ROUND PLUG(23)** into the end of the **HANDLEBAR(15)**.

NOTE: Lubricate the **HANDLEBAR(15)** with a small amount of liquid soap or water for easier installation of the **FOAM GRIP(22)**.

STEP 7

To help install the **BOTTLE HOLDER(27)**, loosen the **SCREW(M4.2x16mm)(67)** on the **RIGHT COVER(18)**. Push the **BOTTLE HOLDER(27)** into the gap of the **LEFT** and **RIGHT COVERS(17, 18)**. Tighten the **SCREW(M4.2x20mm)(16)** on the **RIGHT COVER(18)**. Press the **ENDCAPS(30)** onto both sides of the **REAR STAND(2)**.

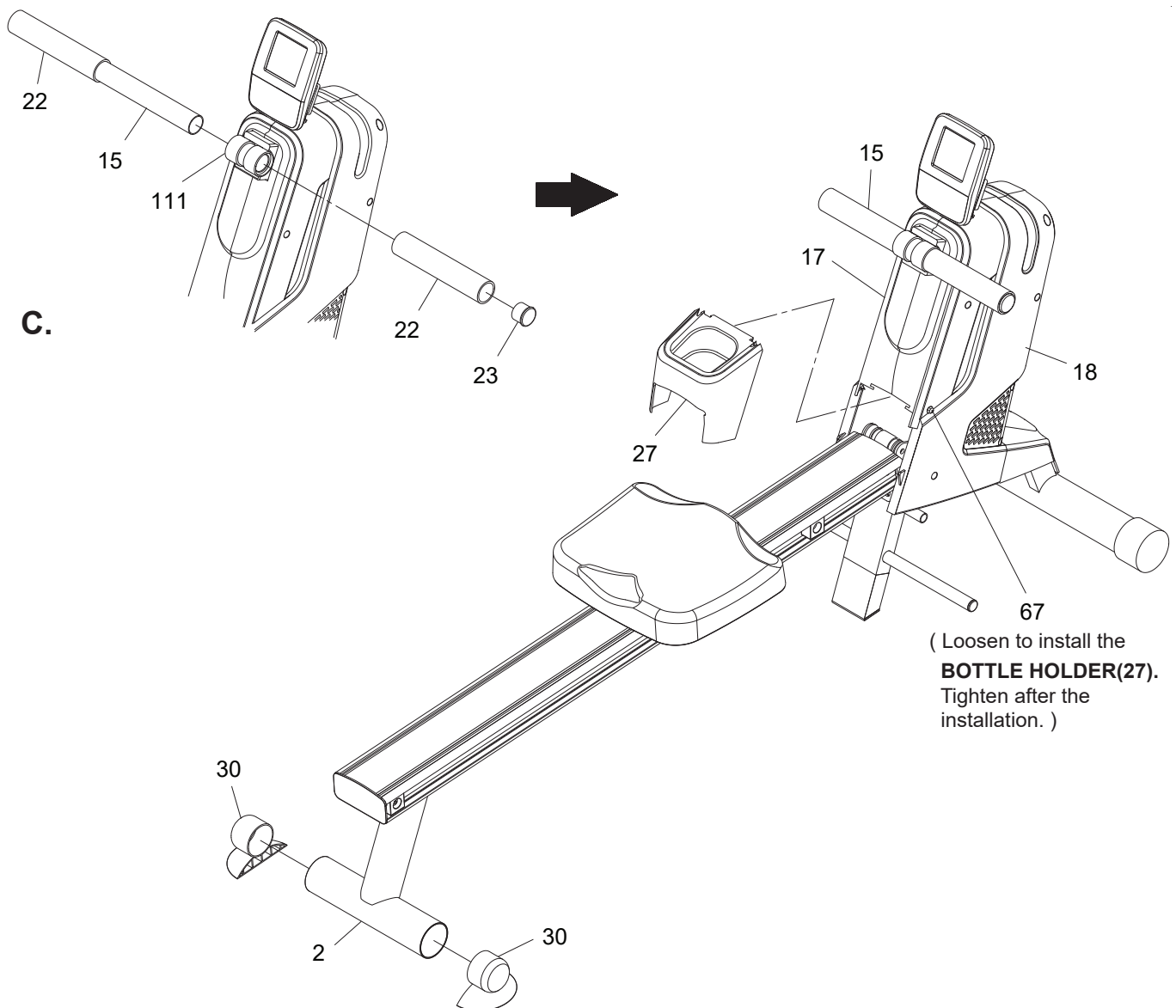

ASSEMBLY INSTRUCTIONS

STEP 8

Insert the **PEDAL SHAFT(6)** through the tube located on the **BASE FRAME(3)**. Slide a **PEDAL CAP(19)** onto each end of the **PEDAL SHAFT(6)**. Then secure the **PEDAL CAPS(19)** with **BUTTON HEAD BOLTS(M8x1.25x15mm)(60)** and **LARGE WASHERS(M8)(83)** at both ends of the **PEDAL SHAFT(6)**. You need to use two Allen Wrenches to tighten the **BUTTON HEAD BOLTS(M8x1.25x15mm)(60)** at both ends of the **PEDAL SHAFT(6)** at the same time.

STEP 9

Refer to detail view. Plug the **ADAPTER(102)** into the **SOCKET** of the **POWER WIRE(100)** located on the front of the rower. Plug the **ADAPTER(102)** into an electrical outlet.

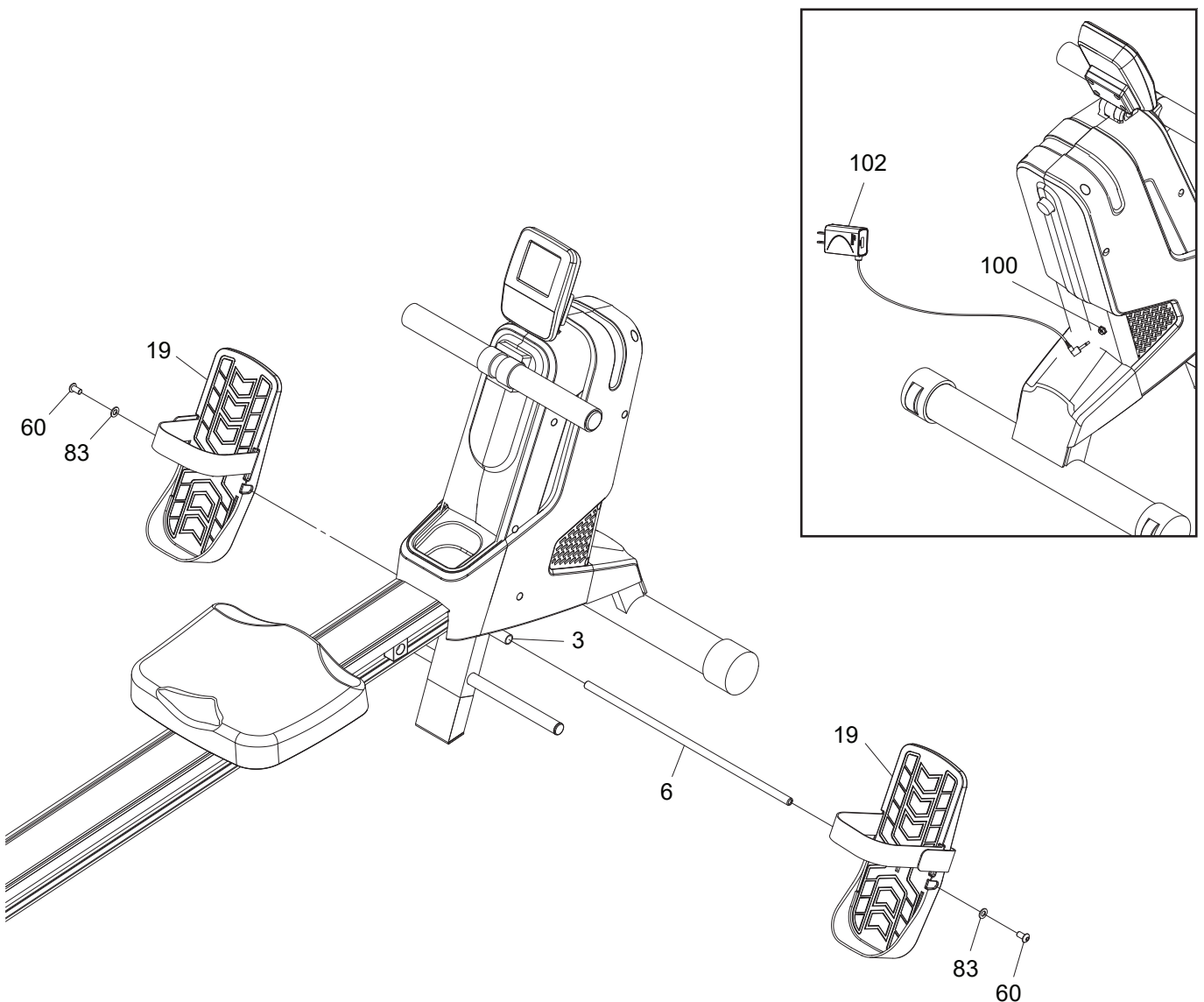

OPERATIONAL INSTRUCTIONS

PEDAL STRAP ADJUSTMENT

If you feel it is more comfortable for your workout, you can attach the **PEDAL STRAP(20)** to the lower position in the **PEDAL CAP(19)** as shown in illustration 1 below. Run the **PEDAL STRAP(20)** through the opening from the bottom of the **PEDAL CAP(19)**. Pull the **PEDAL STRAP(20)** to make the Knot against the bottom of the **PEDAL CAP(19)**. Run the **PEDAL STRAP(20)** through the opening in the **PEDAL CAP(19)** on the other side from the top as shown in the illustration 1, then make the end of the **PEDAL STRAP(20)** go up to attach onto the upper part of the **PEDAL STRAP(20)** with the Hook & Loop Pad. Attach the end of the **PEDAL STRAP(20)** to different position with the Hook & Loop Pad to adjust the length. Refer to illustration 2.

1.

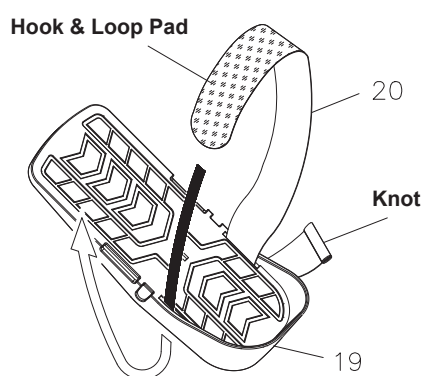

2.

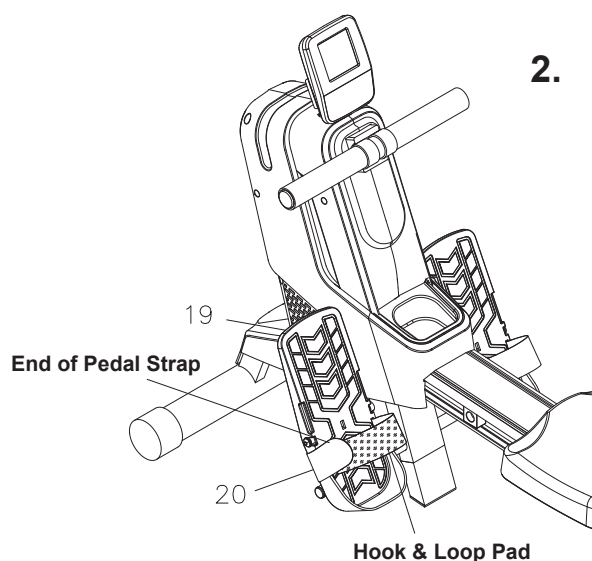

HEART RATE TRANSMITTER

The **Stamina® 1130 Magnetic Rowing Machine** can measure how hard you are exercising by monitoring your heart rate with the **HEART RATE TRANSMITTER(103)**. Your heart rate reading gives you a snapshot of how hard your heart is working at that point in your workout by measuring the number of heart beats per minute.

The **HEART RATE TRANSMITTER(103)** worn around your chest sends your heart rate information to a receiver inside the **COMPUTER(35)** so your heart rate is tracked while you exercise. This is the most reliable way to measure your heart rate to make sure you are exercising within your target heart rate zone so you get the most out of your workout time.

Using the Heart Rate Transmitter Chest Strap

The **HEART RATE TRANSMITTER(103)** worn around the chest is powered by a **BUTTON BATTERY (CR2032)(107)** located in the center of the strap. Two electrodes on either side of the battery monitor your heartbeat, and an adjustable **ELASTIC STRAP(104)** holds the transmitter in place. The receiver built into the **Stamina® 1130 Magnetic Rowing Machine** picks up your heart rate from the **HEART RATE TRANSMITTER(103)** and displays it on the monitor during your workout.

OPERATIONAL INSTRUCTIONS

To assemble the **HEART RATE TRANSMITTER(103)**, insert the **BUTTON BATTERY(CR2032)(107)** as shown in the illustration. Place the **BATTERY RUBBER RING(105)** on the edge of the opening and place the **BATTERY COVER(106)** over the **BUTTON BATTERY(CR2032)(107)**. Using a coin or similar object, press down on the **BATTERY COVER(106)** and turn counterclockwise to securely close the cover.

NOTE:

1. Make sure to close the **BATTERY COVER (106)** very tightly as illustrated to prevent sweat and moisture from damaging the battery.
2. The **HEART RATE TRANSMITTER(103)** is latex free and its material is appropriate for human contact.

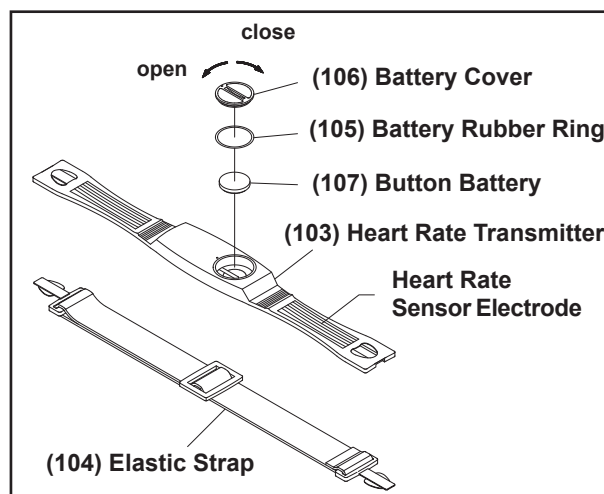

Attach the **ELASTIC STRAP(104)** by inserting the heart-shaped tabs through the openings in the transmitter and twisting. Adjust the **ELASTIC STRAP(104)** to fit your chest snugly as shown in the illustration below.

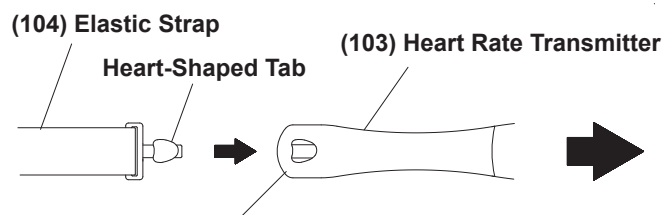

To ensure a secure connection above, be sure that the front edge of the heart-shaped tab is completely inside of the heart-shaped opening on the **HEART RATE TRANSMITTER(103)**.

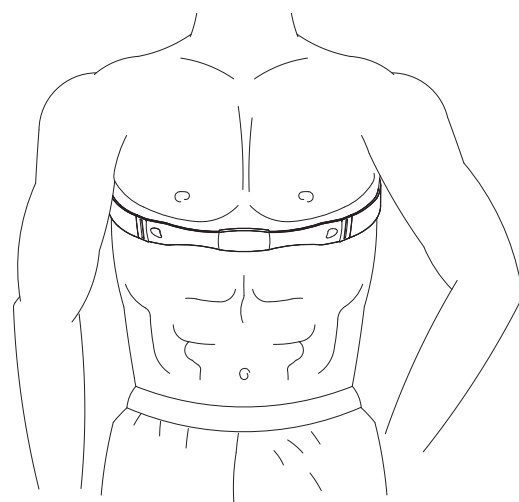

NOTE: If your heart rate is inconsistent or not tracking on your workout monitor, do the following:

- Moisten the heart rate sensor electrodes on the back of the **HEART RATE TRANSMITTER(103)** and make sure they are in contact with the skin. Your skin may be dry when you begin your workout and the moisture is necessary to ensure contact. As you sweat, contact will improve.
- Tighten the elastic strap so it remains in place as you exercise. Movement of the heart rate sensor electrodes will result in inaccurate or erratic signal and readings.
- Clean the heart rate sensor electrodes as dirt can interfere with transmission. Use a mild soap and water and dry with a soft towel.

Transmitter Care and Maintenance

- Wash regularly with mild soap and water solution and dry with a soft towel being careful not to scratch the heart rate sensor electrodes.
- Store in a cool, dry place. Make sure the heart rate sensor electrodes aren't stored with any wet material and never store a wet transmitter in non-breathable material like a plastic bag or sports bag.
- Do not bend or stretch the transmitter.

NOTE: The frequency of the receiver built into the **Stamina® 1130 Magnetic Rowing Machine** is 5 kHz. All compatible heart rate transmitters from other companies will work with the **Stamina® 1130 Magnetic Rowing Machine**.

COMPUTER INSTRUCTIONS

Your **Stamina® 1130 Magnetic Rowing Machine** utilizes a magnetic braking system to create resistance for your workout. You control the amount and pattern of this resistance by means of the advanced computer console built into the **Stamina® 1130 Magnetic Rowing Machine**. We recommend that you use this computer console to vary your workout from session to session and note your progress toward your fitness goals. When used regularly in this way, the computer console can become an important source of motivation and interest which will help keep you on track.

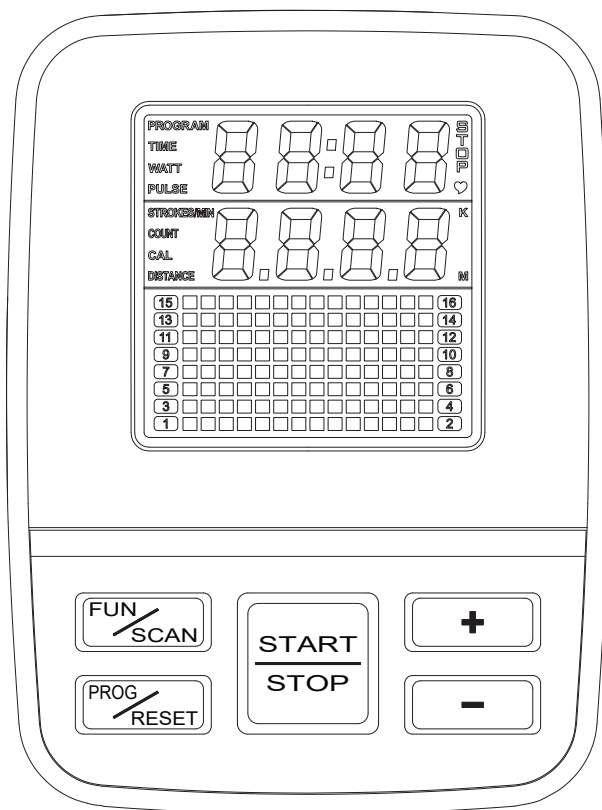

FUNCTION BUTTONS:

- PROG/RESET:** Press to show the programs for selecting from P1 to P9, and U1 to U4.
Press and hold the button down for five seconds to reset all of the function values to zero.
- FUN/SCAN:** In STOP mode, press to select a program from P1 to P9, and U1 to U4. Press to preset the function values for TIME, COUNT, DISTANCE, CALORIES, and PULSE.
During exercise, press to switch the display function values between fixed display or automatically scan display.
- + (UP):** Press to increase the preset values.
Press to increase the level of the workload when running a program.
- (DOWN):** Press to decrease the preset values.
Press to decrease the level of the workload when running a program.
- START/STOP:** Press to start the selected program. Press the **START/STOP** button to stop the program. You can press the **START/STOP** button again to continue to run the current program, or use **PROG/RESET** button to select a new program.

COMPUTER INSTRUCTIONS

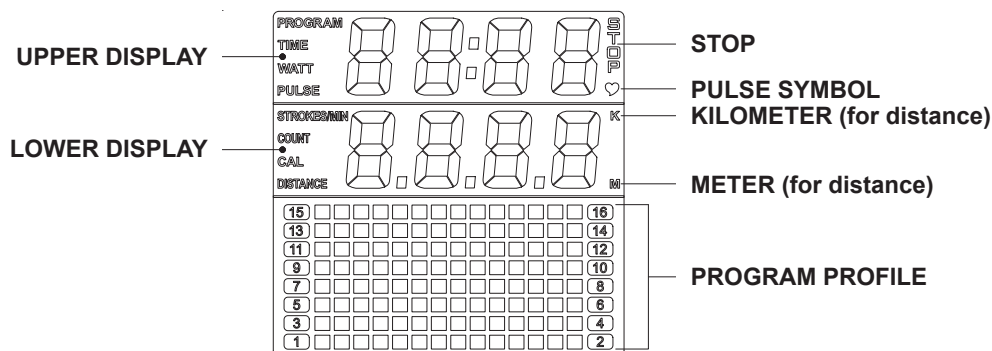

LCD DISPLAY INSTRUCTIONS

STOP: Indicates the program selected has stopped. You must be in the “**STOP**” mode to setup the programs.

PROGRAM: Displays programs for selection during setup from P1 to P9 and U1 to U4. Displays the selected program during exercise.

TIME: Displays flashing “**0:00**” for presetting the program time during setup, from 1:00 to 99:00 for Program 1 (manual program), from 5:00 to 99:00 for P2 to P9 and U1 to U4, and counts down from the preset value.

If no value is preset, displays the time during exercise, from 1 second up to 99:59 minutes.

WATT: Displays the amount of power being exerted from zero to 999 watt.

PULSE: Displays flashing “**90**” for presetting the heart rate limit of your workout during setup, from 90 to 220 beats per minute. When you reach to the heart rate limit during exercise, the pulse readout will flash on the display to warn you.

Displays the heart rate, from 40 to 240 beats per minute during exercise.

NOTE: To use this function, you must wear the **HEART RATE TRANSMITTER(103)** around your chest so the receiver which is built into the rower registers your heart rate from the **HEART RATE TRANSMITTER(103)** for displaying. Each heart rate signal will be accompanied with one “♥” symbol flash. If you do not wear the **HEART RATE TRANSMITTER(103)** around your chest correctly, a “**P**” mark will be displayed.

STROKES/MIN: Displays the current strokes per minute during exercise, from zero to 999 strokes per minute.

COUNT: Displays flashing “**0**” for presetting the number of strokes you want to take during setup, from 10 to 9990, and counts down from the preset value.

If no value is preset, displays the total number of strokes you have taken during exercise, from zero up to 9999 strokes.

DISTANCE: Displays flashing “**0**” for presetting the distance during setup, from 100 meter to 9.9 kilometer, and counts down from the preset value.

If no value is preset, displays the distance you are traveling during exercise, from 1 meter up to 9.999 kilometers.

CALORIES: Displays flashing “**0:0**” for presetting the calories burned during setup, from 1 to 999 Kcal, and counts down from the preset value.

Displays the calories burned, from zero up to 999.9 Kcal.

NOTE: The calorie readouts are an estimate for an average user. It should be used only as a comparison between workouts on this unit.

COMPUTER INSTRUCTIONS

PROGRAM DESCRIPTIONS

This computer contains 13 different programs. You can preset the program time and the computer will divide the time into 12 intervals. If you do not set the program time in advance, the computer will use 1 minute for each interval of Program 1 (Manual program) and cycle through the program, or the computer will use 3 minutes for each interval for other programs and cycle through the program profile.

(PROGRAM 1) MANUAL

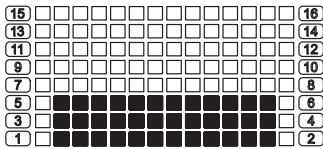

MANUAL PROGRAM: Program 1 is a manual program allowing the user to have full manual control of the workload. Use the “+” button to increase the load. Use the “-” button to decrease the load.

PRESET PROGRAMS: Program 2 to Program 7 are preset automatic programs. The profiles are shown on the face of the computer. Use the “+” button to increase the load level of the program. Use the “-” button to decrease the load level of the program.

(PROGRAM 2) ROLLING

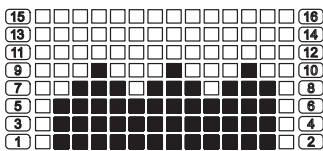

(PROGRAM 3) VALLEY

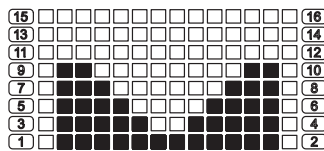

(PROGRAM 4) FAT BURN

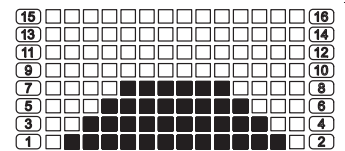

(PROGRAM 5) RAMP

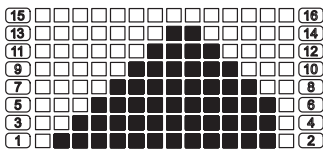

(PROGRAM 6) MOUNTAIN

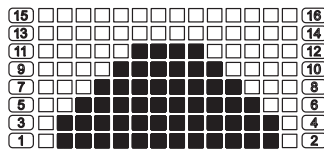

(PROGRAM 7) INTERVALS

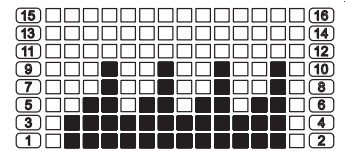

(PROGRAM 8) COMPETITION

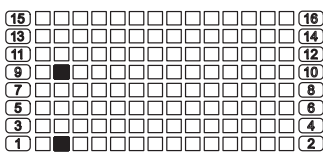

COMPETITION PROGRAM: There are two parts of the display. The upper part shows the workout distance, each bar means 1/10 of preset distance. The lower part shows the workout time, each bar means 1/10 of preset time. So this program is for you to finish 1/10 of the presetted distance during every 1/10 of the presetted time.

When the user finishes each interval of time, and the distance is less than 1/10 of the preset distance, the distance bar will flash for warning. Otherwise the bars will move to next interval, and it means you workout well. If you do not set the program time and distance in advance, the computer will use 10 minutes and 4 kilometer to run the program.

(PROGRAM 9) Target Heart Rate

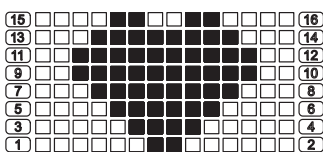

TARGET HEART RATE CONTROL PROGRAM: To use this program, you must wear the **HEART RATE TRANSMITTER(103)** around your chest so the receiver which is built into the rower registers your heart rate from the **HEART RATE TRANSMITTER(103)** for working with this program.

Once Program 9 is selected, the **PULSE** window displays flashing “90” for you to input desired target heart rate, from 90 to 220. The program will monitor your heart rate and adjust the workload automatically during exercise to keep your heart rate within the zone which is plus & minus 5 Heart Beats from the target heart rate you setup.

COMPUTER INSTRUCTIONS

OPERATION INSTRUCTIONS

A. MANUAL AND PRESET PROGRAMS (PROGRAM 1 to PROGRAM 7)

STEP 1: POWER ON

Handlebar Pulling or press any button.

STEP 2 : SELECT PROGRAM

The Program 1 (Manual Program) is always displayed first when you turn on the computer. Press the **FUN/SCAN** button to select the Program 1. Or press the **PROG/RESET** button to select other programs.

STEP 3: SET THE PROGRAM TIME, COUNT, DISTANCE, CALORIES, and PULSE

Press the **FUN/SCAN** button to select the desired program. The computer will go through the input items as follows and allow you to set the function values. Use “**+/-**” and **FUN/SCAN** buttons to input the values. Or press the **FUN/SCAN** button to pass some of the inputs.

Time (5:00* to 99:00) → Count (10 to 9990 rows) → Distance (100 meter to 9.9 Km) → Calories (1 to 999 Kcal) → Pulse (90 to 220 bpm)

**For program 1 (Manual Program), the preset program time is from 1:00 to 99:00 minutes.*

STEP 4 : START TO WORKOUT

Now you are ready to begin exercising. The program will not start until you press the **START/STOP** button.

B. COMPETITION PROGRAM (PROGRAM 8)

STEP 1: POWER ON

Handlebar Pulling or press any button.

STEP 2 : SELECT PROGRAM

Press **PROG/RESET** button until Program 8 is displayed.

STEP 3: SET THE PROGRAM TIME and DISTANCE

Press the **FUN/SCAN** button to select the program. The computer will go through the input items as follows and allow you to set the function values. Use “**+/-**” and **FUN/SCAN** buttons to input the values.

Time (1:00 to 99:00) → Distance (100 meter to 9.9 Km)

(Note: You can only preset the “TIME” and “DISTANCE” for the program.)

STEP 4 : START TO WORKOUT

Press the **START/STOP** button to start to workout.

C. HEART RATE CONTROL PROGRAM (PROGRAM 9)

NOTE: To use this program, you must wear the **HEART RATE TRANSMITTER(103)** around your chest.

STEP 1: POWER ON

Handlebar Pulling or press any button.

STEP 2 : SELECT PROGRAM

Press **PROG/RESET** button until Program 9 is displayed.

STEP 3: SET THE PROGRAM PULSE, TIME, COUNT, DISTANCE, and CALORIES

Press the **FUN/SCAN** button to select the program. The computer will go through the input items as follows and allow you to set the function values. Use “**+/-**” and **FUN/SCAN** buttons to input the values. Or press the **FUN/SCAN** button to pass some of the inputs.

Pulse (90 to 220 bpm) → Time (5:00 to 99:00) → Count (10 to 9990 rows) → Distance (100 meter to 9.9 Km) → Calories (1 to 999 Kcal)

STEP 4 : START TO WORKOUT

Press the **START/STOP** button to start to workout.

COMPUTER INSTRUCTIONS

D. USER SETTING PROGRAMS (PROGRAM U1 to PROGRAM U4)

STEP 1: POWER ON

Handlebar Pulling or press any button.

STEP 2 : SELECT PROGRAM

Press **PROG/RESET** button until the desired program is displayed.

STEP 3: SET THE PROGRAM TIME, COUNT, DISTANCE, CALORIES, and PULSE

Press the **FUN/SCAN** button to select the program. The computer will go through the input items as follows and allow you to set the function values. Use “**+/-**” and **FUN/SCAN** buttons to input the values. Or press the **FUN/SCAN** button to pass some of the inputs.

Time (5:00 to 99:00) → Count (10 to 9990 rows) → Distance (100 meter to 9.9 Km) → Calories (1 to 999 Kcal) → Pulse (90 to 220 bpm)

STEP 4 : EDIT THE PROGRAM PROFILE

Press the **FUN/SCAN** button, interval 1 will begin flashing. Use “**+/-**” buttons to set the load for interval 1. Press the **FUN/SCAN** button to proceed to the next interval. Use “**+/-**” buttons to set the load for each interval.

STEP 5 : START TO WORKOUT

Press the **START/STOP** button to start to workout.

OPERATION DESCRIPTIONS

1. You may preset values for several functions. The preset function values will start to count down once you press the **START/STOP** button to start exercising. Preset values will only count down, they will not count up. When you complete one of the preset functions, the computer will remind you with an audible alarm for ten seconds and stops running the program. Press any button to stop the audible alarm. Two possible options follow: Option A: press the **START/STOP** button to continue to run the current program. The value of this completed function will start to count up, while the other preset functions will continue to count down until you reach the next preset function. Option B: press **PROG/RESET** button to select a new program.
2. To stop a running program, press the **START/STOP** button. In this mode, you can press the **START/STOP** button again to continue to run the current program. Or, you can use **PROG/RESET** button to select a new program.
3. If you want to restart with a new program, press the **PROG/RESET** button and hold it down for five seconds to reset all of the function values to zero. Use **PROG/RESET** button to select a new program.
4. The computer will shut off automatically after 4 minutes of inactivity and all function values will be reset to zero.

POWER SOURCE:

The computer uses the **ADAPTER(102)** as a power source. Use the **Stamina® 1130 Magnetic Rowing Machine** with the **ADAPTER(102)** plugged into an electrical outlet.

STORAGE

1. To store the **Stamina® 1130 Magnetic Rowing Machine**, simply keep it in a clean dry place.
2. Move the **Stamina® 1130 Magnetic Rowing Machine** with the moving wheels on the Front Stabilizer of the **BASE FRAME(3)**. Lift the **REAR STAND(2)** to move the **Stamina® 1130 Magnetic Rowing Machine**. Do not use the **SEAT(21)** to move the **Stamina® 1130 Magnetic Rowing Machine**. The **SEAT(21)** will move and the **SEAT CARRIAGE(10)** may pinch your hand or fingers.
3. Refer to the illustration below. You can stand the **Stamina® 1130 Magnetic Rowing Machine** on end for storage.

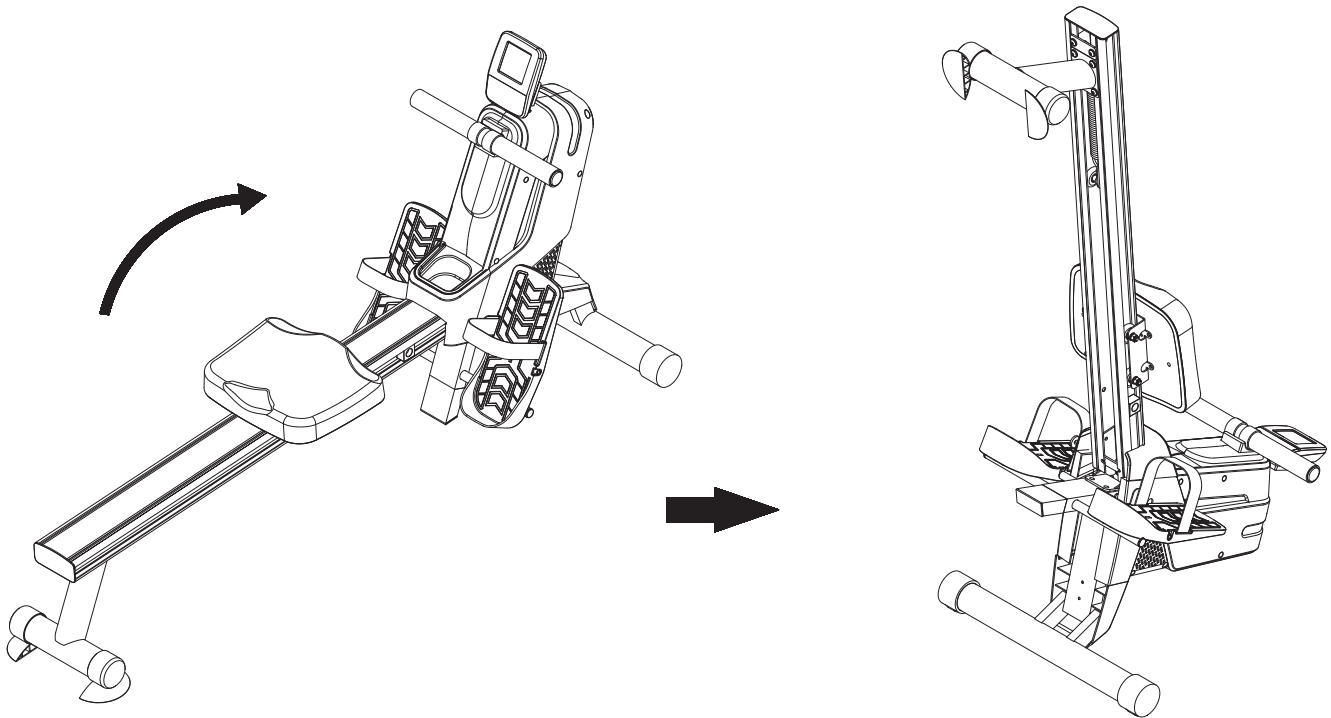

MAINTENANCE

The safety and integrity designed into the **Stamina® 1130 Magnetic Rowing Machine** can only be maintained when the **Stamina® 1130 Magnetic Rowing Machine** is regularly examined for damage and wear. Special attention should be given to the following:

1. Pull on the **HANDLEBAR(15)** and verify that the Magnetic System provides tension and the seat travel is smooth and stable.
2. Clean the roller tracks in the **RAIL(48)** with an absorbent cloth.
3. Verify that all nuts and bolts are present and properly tightened. Replace missing nuts and bolts. Tighten loose nuts and bolts.
4. Check the condition of the **STRAP(25)**. Replace the **STRAP(25)** if it is cracked or broken.
5. Verify that the **CAUTION LABEL(109)** is in place and easy to read. Call Stamina Products immediately at **1-800-375-7520** for a replacement **CAUTION LABEL(109)** if it is missing or damaged.
6. It is the sole responsibility of the user/owner to ensure that regular maintenance is performed.
7. Worn or damaged components shall be replaced immediately or the **Stamina® 1130 Magnetic Rowing Machine** removed from service until repair is made.
8. Only Stamina Products supplied components shall be used to maintain/repair the **Stamina® 1130 Magnetic Rowing Machine**.
9. Keep your **Stamina® 1130 Magnetic Rowing Machine** clean by wiping it off with an absorbent cloth after use.

CONDITIONING GUIDELINES

How you begin your exercise program depends on your physical condition. If you have been inactive for several years or are severely overweight, start slowly and increase your workout time gradually. Increase your workout intensity gradually by monitoring your heart rate while you exercise.

Remember to follow these essentials:

- Have your doctor review your training and diet programs.
- Begin your training program slowly with realistic goals that have been set by you and your physician.
- Warm up before you exercise and cool down after you work out.
- Take your pulse periodically during your workout and strive to stay within a range of 60% (lower intensity) to 90% (higher intensity) of your maximum heart rate zone. Start at the lower intensity, and build up to higher intensity as you become more aerobically fit.
- If you feel dizzy or lightheaded you should slow down or stop exercising.

Initially you may only be able to exercise within your target zone for a few minutes; however, your aerobic capacity will improve over the next six to eight weeks. It is important to pace yourself while you exercise so you don't tire too quickly.

To determine if you are working out at the correct intensity, use a heart rate monitor or use the table below. For effective aerobic exercise, your heart rate should be maintained at a level between 60% and 90% of your maximum heart rate. If just starting an exercise program, work out at the low end of your target heart rate zone. As your aerobic capacity improves, gradually increase the intensity of your workout by increasing your heart rate.

Measure your heart rate periodically during your workout by stopping the exercise but continuing to move your legs or walk around. Place two or three fingers on your wrist and take a six second heartbeat count. Multiply the results by ten to find your heart rate. For example, if your six second heartbeat count is 14, your heart rate is 140 beats per minute. A six second count is used because your heart rate will drop rapidly when you stop exercising. Adjust the intensity of your exercise until your heart rate is at the proper level.

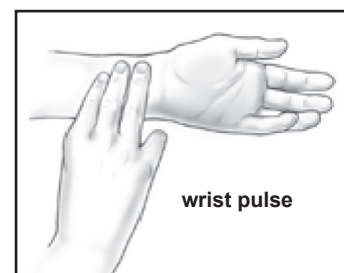

Target Heart Rate Zone Estimated by Age*

Age	Target Heart Rate Zone (55%-90% of Maximum Heart Rate)	Average Maximum Heart Rate 100%
20 years	110-180 beats per minute	200 beats per minute
25 years	107-175 beats per minute	195 beats per minute
30 years	105-171 beats per minute	190 beats per minute
35 years	102-166 beats per minute	185 beats per minute
40 years	99-162 beats per minute	180 beats per minute
45 years	97-157 beats per minute	175 beats per minute
50 years	94-153 beats per minute	170 beats per minute
55 years	91-148 beats per minute	165 beats per minute
60 years	88-144 beats per minute	160 beats per minute
65 years	85-139 beats per minute	155 beats per minute
70 years	83-135 beats per minute	150 beats per minute

* For cardiorespiratory training benefits, the American College of Sports Medicine recommends working out within a heart rate range of 55% to 90% of maximum heart rate. To predict the maximum heart rate, the following formula was used: $220 - \text{Age} = \text{predicted maximum heart rate}$

WARM-UP and COOL-DOWN

Warm-Up The purpose of warming up is to prepare your body for exercise and to minimize injuries. Warm up for two to five minutes before strength training or aerobic exercising. Perform activities that raise your heart rate and warm the working muscles. Activities may include brisk walking, jogging, jumping jacks, jump rope, and running in place.

Stretching Stretching while your muscles are warm after a proper warm-up and again after your strength or aerobic training session is very important. Muscles stretch more easily at these times because of their elevated temperature, which greatly reduces the risk of injury. Stretches should be held for 15 to 30 seconds. Do not bounce.

Suggested Stretching Exercises

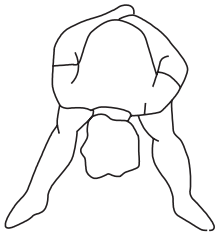

Lower Body Stretch

Place feet shoulder-width apart and lean forward. Keep this position for 30 seconds using the body as a natural weight to stretch the backs of the legs. **DO NOT BOUNCE!** When the pull on the back of the legs lessens, gradually try a lower position.

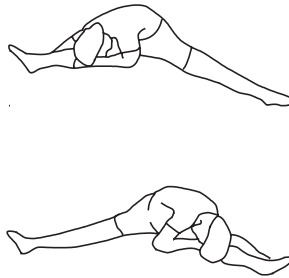

Floor Stretch

While sitting on the floor, open the legs as wide as possible. Stretch the upper body toward the knee on the right leg by using your arms to pull your chest to your thighs. Hold this stretch 10 to 30 seconds. **DO NOT BOUNCE!** Do this stretch 10 times. Repeat the stretch with the left leg.

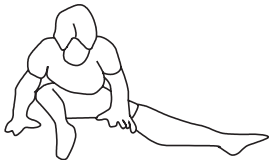

Bent Torso Pulls

While sitting on the floor, have legs apart, one leg straight and one knee bent. Pull the chest down to touch the thigh on the leg that is bent, and twist at the waist. Hold this position at least 10 seconds. Repeat 10 times on each side.

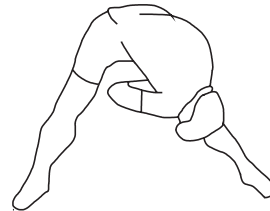
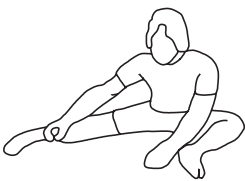

Bent Over Leg Stretch

Stand with feet shoulder-width apart and lean forward as illustrated. Using the arms, **gently** pull the upper body towards the right leg. Let the head hang down. **DO NOT BOUNCE!** Hold the position a minimum of 10 seconds. Repeat pulling the upper body to the left leg. Do this stretch several times slowly.

Remember to always check with your physician before starting any exercise program.

Cool-Down The purpose of cooling down is to return the body to its normal, or near normal, resting state at the end of each exercise session. A proper cool-down slowly lowers your heart rate and allows blood to return to the heart. Your cool-down should include the stretches listed above and should be completed after each strength training session.

PRODUCT PARTS DRAWING

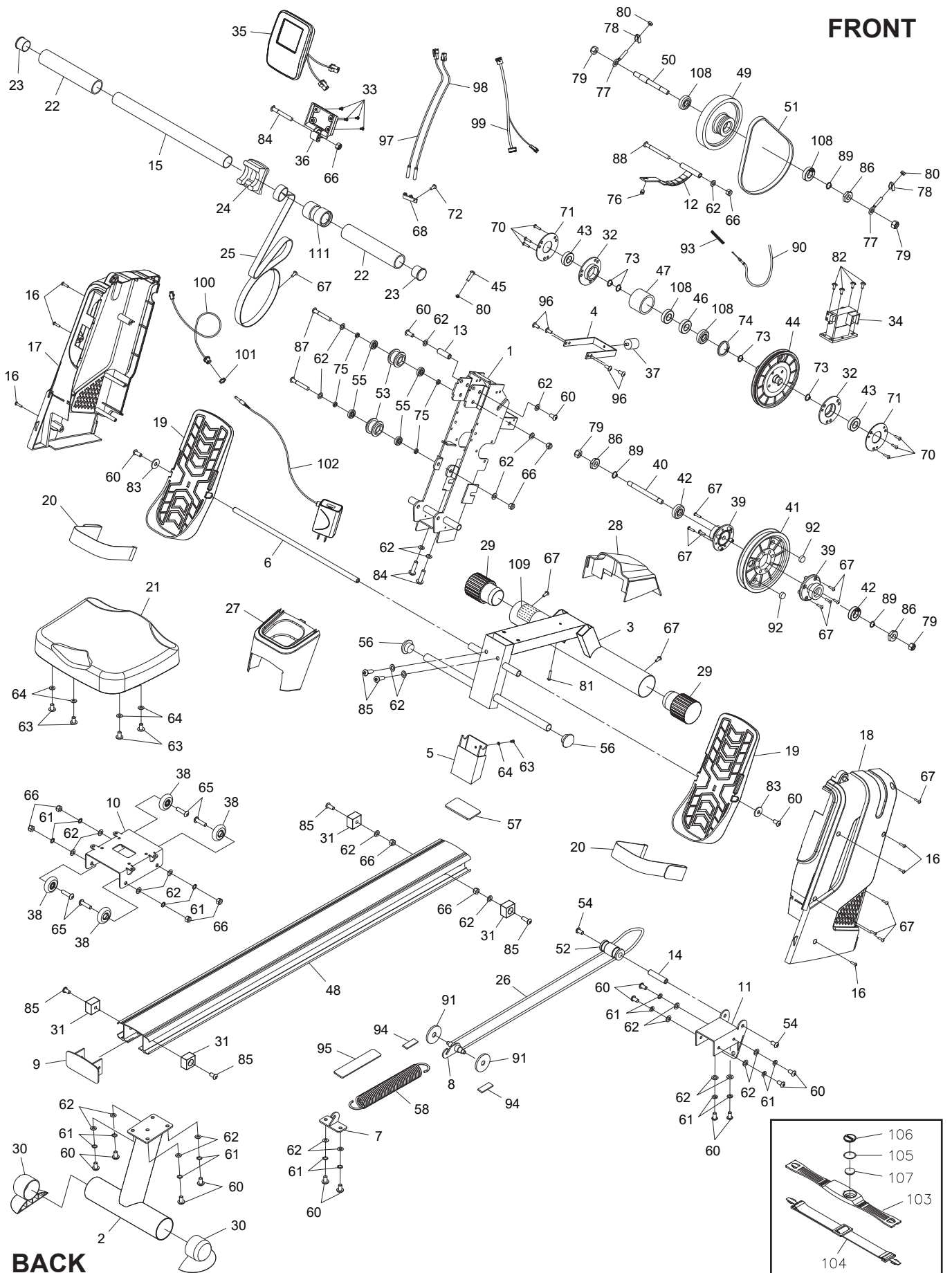

PARTS LIST

PART#	PART NAME	QTY
1	Main Frame	1
2	Rear Stand	1
3	Base Frame	1
4	Foot Bracket	1
5	Rear Support	1
6	Pedal Shaft	1
7	Rear Spring Hook	1
8	Spring Hook	1
9	Rail Cap	1
10	Seat Carriage	1
11	Connection Bracket	1
12	Magnetic Brake	1
13	Spacer (ø12.8 x 38.5mm)	1
14	Shaft Rod (ø12.8 x 58.5mm)	1
15	Handlebar	1
16	Screw, Round Head Self-Drill (M4.2 x 20mm)	6
17	Left Cover	1
18	Right Cover	1
19	Pedal Cap	2
20	Pedal Strap	2
21	Seat	1
22	Foam Grip	2
23	Round Plug (ø32mm)	2
24	Handlebar Holder	1
25	Strap	1
26	Return Strap	1
27	Bottle Holder	1
28	Front Cover	1
29	Wheel Cap	2
30	Endcap (60mm)	2
31	Seat Stopper	4
32	Bearing Housing	2
33	Screw, Round Head (M5 x 0.8 x 20mm)	4
34	Control Motor	1
35	Computer	1
36	Meter Plate	1
37	Foot Stand	1
38	Roller	4
39	Return Bearing Housing	2
40	Strap Pulley Shaft	1
41	Strap Pulley	1
42	Bearing (6000RS)	2
43	Bearing (6003zz)	2
44	Pulley	1
45	Bolt, Round Head (M6 x 1 x 25mm)	1
46	One-way Bearing (16003)	1
47	Collar	1
48	Rail	1
49	Magnetic Flywheel	1
50	Flywheel Shaft	1
51	V-Ribbed Belt	1
52	Idler Roller	1
53	Idler Wheel	2
54	Bolt, Button Head (M8 x 1.25 x 20mm)	2
55	Bearing (608zz)	4
56	Round Plug (ø19mm)	2

PARTS LIST

PART#	PART NAME	QTY
57	Foot Pad	1
58	Return Spring	1
59	Allen Wrench (5mm)	1
60	Bolt, Button Head (M8 x 1.25 x 15mm)	16
61	Lock Washer (M8)	16
62	Washer (M8)	29
63	Bolt, Round Head (M6 x 1 x 15mm)	5
64	Washer (M6)	5
65	Bolt, Flat Button Head (M8 x 1.25 x 32mm)	4
66	Nylock Nut (M8 x 1.25)	10
67	Screw, Round Head (M4.2 x 16mm)	14
68	Sensor Clip	1
69	Allen Wrench (5mm) w/ Screwdriver	1
70	Bolt, Round Head (M6 x 1 x 12mm)	6
71	Bearing Housing Cover	2
72	Screw, Round washer Head (M4 x 0.7 x 10mm)	1
73	C Ring (M17)	4
74	Inner C Ring (M35)	1
75	Spacer (ø8 x ø10 x 7mm)	4
76	Retaining Plug	1
77	Eye Bolt (M6 X 1)	2
78	Tension Bracket	2
79	Nut (M10 x 1.5)	4
80	Nut (M6 x 1)	3
81	Screw, Round Head (M4.2 x 45mm)	1
82	Screw, Round Head (M5 x 0.8 x 12mm)	4
83	Large Washer (M8)	2
84	Bolt, Button Head (M8 x 1.25 x 40mm)	3
85	Bolt, Button Head (M8 x 1.25 x 20mm)	6
86	Thin Nut (M10 x 1.5, 5mm thick)	3
87	Bolt, Button Head (M8 x 1.25 x 60mm)	2
88	Bolt, Button Head (M8 x 1.25 x 80mm)	1
89	C Ring (M10)	3
90	Tension Cable	1
91	Guide Wheel	2
92	Magnet	2
93	Spring	1
94	EVA Pad (180 x 30 x 1mm thick)	2
95	EVA Pad (65 x 15 x 1mm thick)	1
96	Bolt, Small Round Head (M6 x 1 x 12mm)	4
97	Female Sensor Wire	1
98	Male Sensor Wire	1
99	Magnetic Control Cable	1
100	Power Wire	1
101	Plug Nut	1
102	Adapter, Output 9V DC, 1A	1
103	Heart Rate Transmitter	1
104	Elastic Strap	1
105	Battery Rubber Ring	1
106	Battery Cover	1
107	Button Battery (CR2032)	1
108	Bearing (6003RS)	4
109	Caution Label	1
110	Manual	1
111	Handlebar Sleeve	1

WARRANTY

Stamina Products, Inc. warrants that this product will be free from defects in materials and workmanship under normal use, service, proper assembly and proper operation for a period of 90 days on the parts and three years on the frame from the date of the original purchase from an authorized retailer. **THIS WARRANTY SHALL NOT APPLY TO ANY PRODUCT WHICH HAS BEEN SUBJECT TO COMMERCIAL USE, ABUSE, MISUSE, ALTERATION OF ANY TYPE OR CAUSE OR TO ANY DEFECT OR DAMAGE CAUSED BY IMPROPER ASSEMBLY, REPAIR, REPLACEMENT, SUBSTITUTION OR USE WITH PARTS OTHER THAN PARTS PROVIDED BY STAMINA PRODUCTS, INC.** Commercial use includes use of the product in athletic clubs, health clubs, spas, gymnasiums, exercise facilities, and other public or semipublic facilities whether or not the product's use is in furtherance of a profit making enterprise, and all other use which is not for personal, family, or household purposes.

To implement this limited warranty, send a written notice stating your name, date, and place of purchase and a brief description of the defect along with your receipt to **Stamina Products, Inc. P.O. Box 1071, Springfield Missouri, USA, 65801-1071**, or email us at **customer.care@staminaproducts.com**, or call us at **1-800-375-7520**. If the defect is covered under this limited warranty, you will be requested to return the product or part to us for free repair or replacement at our option. **NO ACTION FOR BREACH OF THIS LIMITED WARRANTY MAY BE COMMENCED MORE THAN ONE (1) YEAR AFTER THE DATE THE ALLEGED BREACH WAS OR SHOULD HAVE BEEN DISCOVERED. NO ACTION FOR BREACH OF ANY IMPLIED WARRANTY MAY BE COMMENCED MORE THAN ONE (1) YEAR AFTER DELIVERY OF THE PRODUCT TO THE PURCHASER.** This limited warranty is not transferable. **IF ANY PART OF THE PRODUCT IS NOT IN COMPLIANCE WITH THIS LIMITED WARRANTY OR ANY IMPLIED WARRANTY, THE REMEDY OF REPAIR OR REPLACEMENT IS THE EXCLUSIVE REMEDY AVAILABLE TO YOU.** In the event that the purchaser makes any claim under this limited warranty or any implied warranty, the Warrantor reserves the right to require the product to be returned for inspection, at the purchaser's expense, to the Warrantor's premises in Springfield, Missouri. Return of the enclosed warranty registration card is not required for warranty coverage, but is merely a way of establishing the date and place of purchase.

Stamina Products, Inc. **SHALL NOT BE LIABLE FOR THE LOSS OF USE OF ANY PRODUCT, LOSS OF TIME, INCONVENIENCE, COMMERCIAL LOSS OR ANY OTHER INDIRECT, CONSEQUENTIAL, SPECIAL OR INCIDENTAL DAMAGES DUE TO BREACH OF THE ABOVE WARRANTY OR ANY IMPLIED WARRANTY.**

This limited warranty is the only written or express warranty given by Stamina Products, Inc. This warranty gives you specific legal rights, and you may also have other legal rights which vary from state to state. **ANY OTHER RIGHT WHICH YOU MAY HAVE, INCLUDING ANY IMPLIED WARRANTY OR MERCHANTABILITY OR FITNESS FOR A PARTICULAR PURPOSE, IS LIMITED IN DURATION TO THE DURATION OF THIS WARRANTY.**

The laws in some jurisdictions restrict the rights of manufacturers and distributors of consumer goods to disclaim or limit implied warranties and consequential and incidental damages with respect thereto. If any such law is found to be applicable, the foregoing disclaimers and limitations of and on implied warranties and consequential and incidental damages with respect thereto shall be disregarded and shall be deemed not to have been made to the extent necessary to comply with such legal restriction.

NOTES

TO CONTACT CUSTOMER CARE

For your convenience, Stamina's customer care representatives can be reached by email at customer.care@staminaproducts.com or by phone at 1-800-375-7520 (in the U.S.). Our customer care representatives are available Monday through Thursday from 7:30 a.m. until 5:00 p.m., and Friday 8:00 a.m. until 3 p.m. Central Time.



**ONLINE
CUSTOMER CARE**
customer.care@staminaproducts.com
www.staminaproducts.com



**TELEPHONE
CUSTOMER CARE**
Tel: 1 (800) 375-7520



**FAX
CUSTOMER CARE**
Fax: (417) 889-8064



MAIL
STAMINA PRODUCTS, INC.
ATTN: Customer Care
P.O. Box 1071 Springfield, MO. 65801-1071

Would you like to receive email information or special offers from Stamina Products? Register at contact.staminaproducts.com

TO REGISTER YOUR PRODUCT

To enact your warranty, please register your product by going to register.staminaproducts.com. Please have your product model number (printed on the cover of this owner's manual) and the serial number (printed on the black and white sticker on your product) ready.

If you don't have internet access, you can call customer care at 1-800-375-7520, or fill out and mail the product registration form below to Stamina Products, Inc.; P.O. Box 1071; Springfield, MO 65801-1071.

PRODUCT REGISTRATION FORM	Stamina Products, Inc. P.O. Box 1071 Springfield, MO 65801-1071	
Model Number:	Serial Number:	
Product Name:		
Place Purchased:		
Date of Purchase:	Purchase Price:	
First Name:	Last Name:	
City:	State:	Zip Code:
Email Address:	Phone #: ()	
Would you like to receive email information or special offers from Stamina Products?* <input type="checkbox"/> Yes <input type="checkbox"/> No *If yes, be sure your email address is included above.		



Detach and Mail or Fax the Form Above



TO ORDER PARTS

If there are missing or damaged parts, you can go to parts.staminaproducts.com and order those parts. If you have questions, please contact customer care. Do not return the product. To order parts by mail, fill out the sheet below and fax it to 417-889-8064. The part will be mailed to your address.



Detach and Mail or Fax the Form Below



PARTS ORDER FORM	Stamina Products, Inc. P.O. Box 1071 Springfield, MO 65801-1071	
Mr./Ms:		
Address:		
Apt. #:		
City:	State:	Zip Code:
IMPORTANT : We require your phone number to process the order!		
Phone #: ()	Work Phone #: ()	
Date of Purchase:		
Model #:		
Purchased From:		
IMPORTANT: Before filling out the portion below, make sure you have the correct information. Refer to the parts list to make sure you're ordering the right parts!		
PART #	DESCRIPTION	QUANTITY
EXAMPLE: 1	Rear Unit Assembly	1