

FIRST DEGREE FITNESS
Fluid INNOVATION

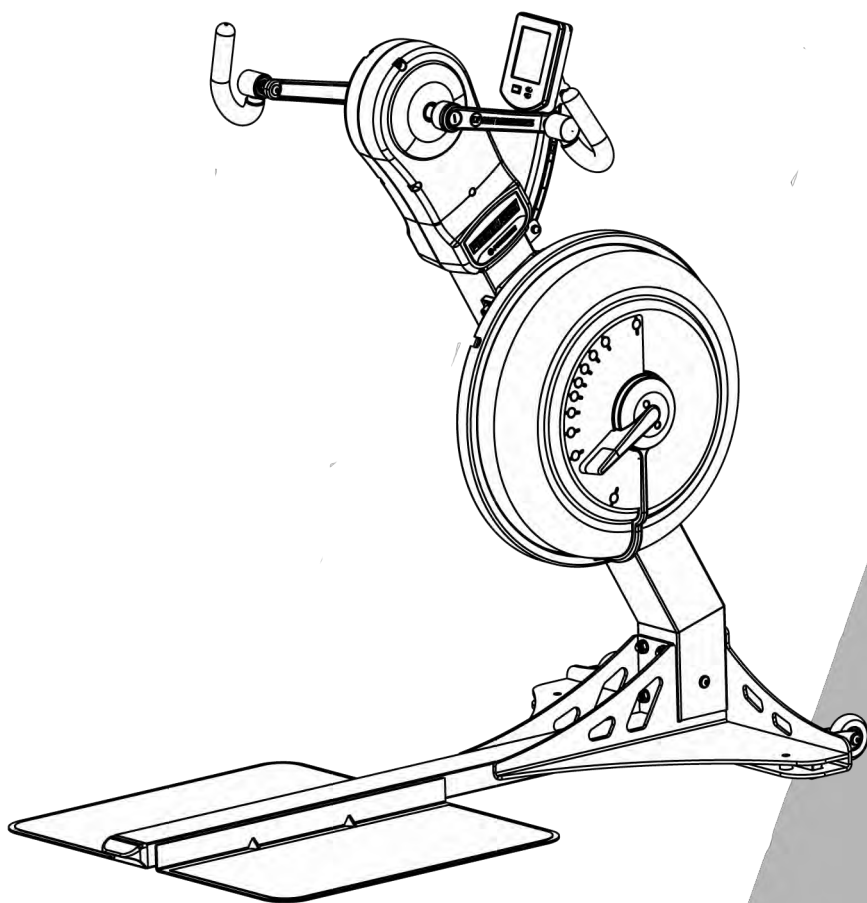

» USER GUIDE

POWER UBE



**FLUID
POWER
ZONE**

REGISTER YOUR PRODUCT AT WWW.FIRSTDEGREEFITNESS.COM/SUPPORT

Introduction

WELCOME TO YOUR POWER UBE

Congratulations on your purchase – the POWER UBE is constructed for high intensity, powerful workouts. The unit's step on design, small footprint and wide foot plates provide instant access and total stability as power is transmitted from the ground up.

Perfect for circuit training as well as CrossFit, the POWER UBE offers a bullet proof platform to achieve an entire body workout allowing integrated movement of the user's core and upper body. Its bi-directional function offers huge advantage for rehabilitation purposes, enabling reciprocal muscle group balance and support of major joints.

Whether you are a veteran, athlete or somewhere in between, the POWER UBE is designed to target strength, endurance, intensity, agility, stability, flexibility and balance through each workout.

Visit our website for workout tips and product support.

PRODUCT REGISTRATION AND SERIAL NUMBER

TO VALIDATE WARRANTY SUPPORT, RECORD YOUR UNIQUE PRODUCT PURCHASE BELOW AND SAVE YOUR ORIGINAL RECEIPT.

SERIAL NO.

DATE OF PURCHASE

TO REGISTER YOUR PRODUCT WARRANTY ONLINE OR UNDERSTAND THE TERMS OF YOUR WARRANTY VISIT
WWW.FIRSTDEGREEFITNESS.COM/SUPPORT

If you are making a warranty claim, please contact your local FDF Dealer In the first instance.

» Contents

Safety	5
Assembly	6
POWER UBE Box 1 & 2 Contents	7
Assembly Instructions	8
Operating Instructions.....	11
Bluetooth Auto-Adjust Monitor.....	13
Calibration Procedure	14
Maintenance & Troubleshooting	15
International Warranty.....	16

All users should read the operating instructions contained within this manual and understand how to use the Power UBE before use. Visit www.firstdegreefitness.com for additional information on technique and training instruction.

NOTE THE FOLLOWING SAFETY PRECAUTIONS:

1. **CAUTION:** As with all fitness programs it is advisable to consult a physician before undertaking exercise of a strenuous nature.

If you experience any pain or dizziness while exercising, stop immediately and consult your physician. Warm up before undertaking any strenuous exercise.
2. Know your heart rate and/or pulse, and physician recommended heart rate training zone. Note that heart rate monitoring systems may be inaccurate and cannot be fully relied upon.
3. Our safety guarantee is based on the user conducting routine checks on key components such as belts, pulleys and bungee cords for signs of wear and tear. Should defective components be identified, replace and/or keep the unit out of use until it is repaired.
4. Wear comfortable clothing that allows freedom of movement and shoes with non-slip soles.
5. The POWER UBE is not suitable for therapeutic purposes. Perform exercises with correct technique and consult a personal trainer for guidance if unsure.
6. Do not remove hands from the handles while the crank is in motion. The crank will continue to rotate and could cause injury.
7. For maximum stability always assemble and operate your POWER UBE on a stable, flat surface.
8. For your safety always ensure your POWER UBE has adequate space around it. The free area should be no less than 600mm on either side of the unit's access points. This must also include the area for emergency dismount.

NOTE: Where equipment is placed adjacent to each other, the free area may be shared.
9. Keep fingers clear of pivot points during both assembly and use as indicated by the warning decals on the main-frame.
10. Do not leave children alone to operate the machine.
11. Use only the adjustment settings as described in the instructions.
12. Never leave any adjustment devices projecting from the unit.

KEEP THESE INSTRUCTIONS

» Assembly

Product Specifications

Product Class: SC

Braking System: Speed Independent

Product Net Weight: 71.13kg (156.81lb)

Product Gross Weight: 84.75kg (186.84lb)

Maximum Safe Operating Surface Area: 2540mm (100.00") Length x 1950mm (76.77") Width

Dimensions: 1340mm (52.76") Length x 750mm (29.53") Width x 1348mm (53.07") Height

Maximum User Weight: 180kg (396.83lbs)

Footprint: 1940mm x 1350mm or upright 1348mm x 750mm

Product Highlights

Fixed crank arm for robust durability.

10 levels of Variable Fluid Resistance at the turn of a dial-perfect for multi-user facilities.

Bi-directional rotation for complete muscle engagement

Wide footplates for optimum power and stability driven workouts from the ground up.

Instant step-on access with nothing to adjust.

Compact footprint with built-in transport wheels for easy movement.

Live area and

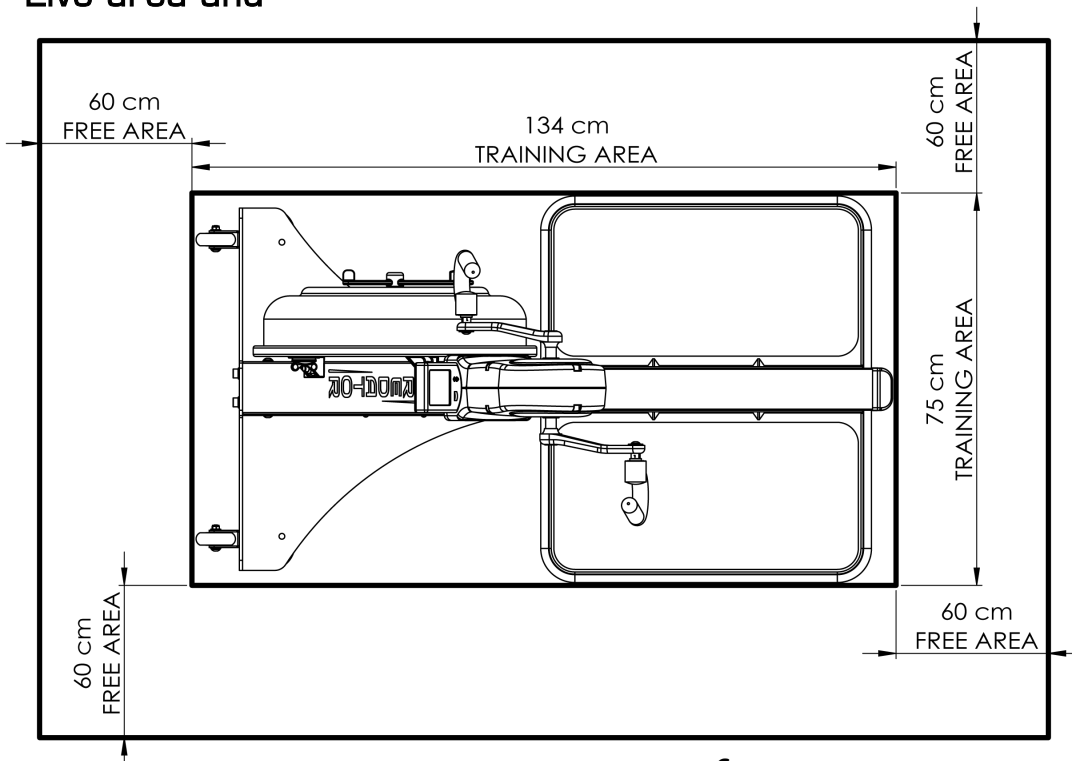

POWER UBE Box 1 & 2 Contents

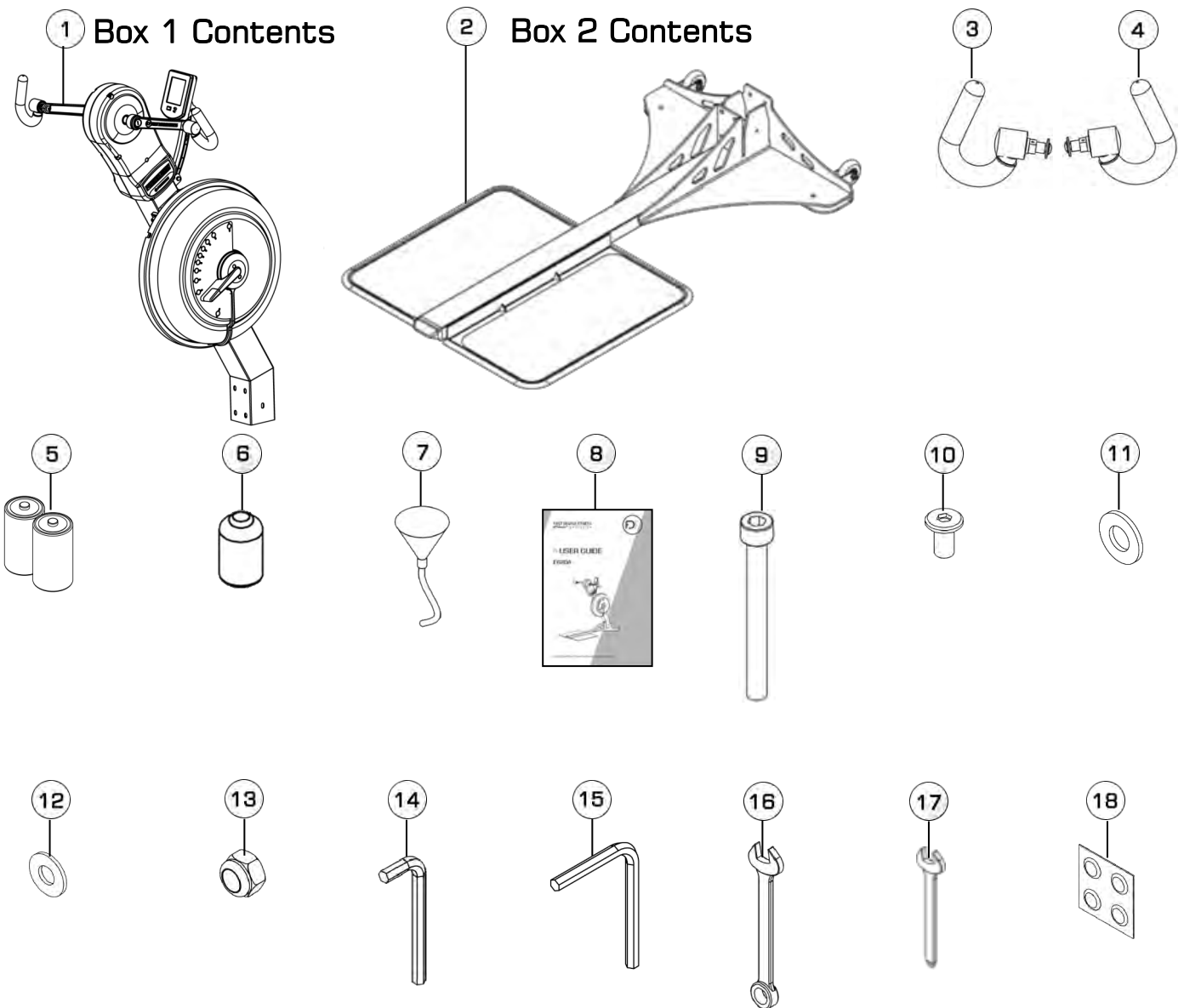

Item	Qty.	Description	Item	Qty.	Description
1	1	Upper Main Frame	5	2	D Cell Duracell Battery
2	1	Lower Main Frame	6	1	Touch Up Paint
3	1	Left Handle	7	1	Funnel and Hose
4	1	Right Handle	8	1	User Guide
Hardware KIT					
9	4	M10x130 Hex Head Bolt	14	1	8mm Allen Key
10	2	M8x15 Dome Head Bolt	15	1	6mm Allen Key
11	8	M10 Washer	16	1	17mm Spanner
12	2	M8 Washer	17	1	15mm Spanner
13	4	M10 Nylock Nut	18	4	Water Treatment Tablet

» Assembly Instructions

STEP 1

ATTACH THE LOWER FRAME TO THE UPPER FRAME

- a) Place the lower frame [2] on a flat surface.
- b) Lift the upper frame [1] carefully and insert slowly into the lower frame's [2] bracket.

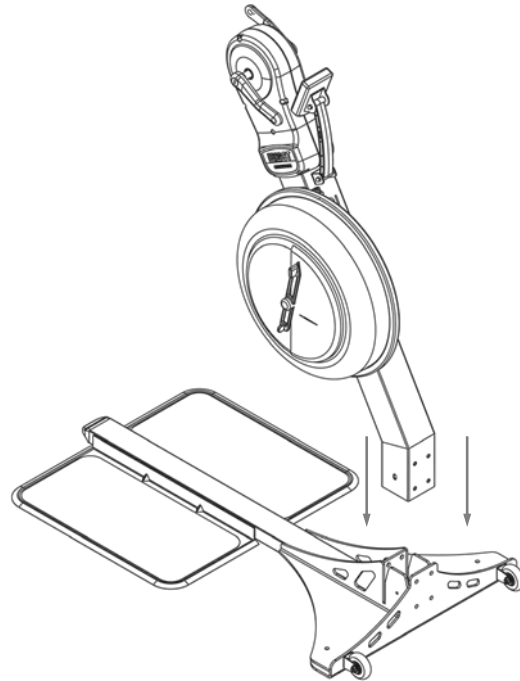
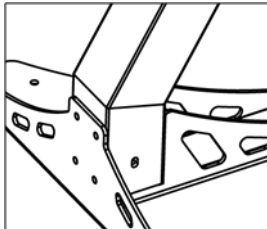
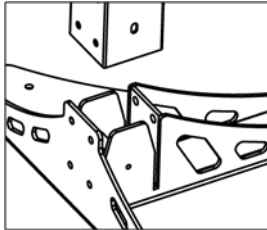

Assembly Instructions

STEP 2

SECURE UPPER AND LOWER FRAME

REQUIRED

4xM10x130mm Bolts [9]

8xM10 Washers [11]

4xM10 Nylock Nuts [13]

17mm Spanner [16]

8mm Allen Key [14]

Torque: 240Kgf.cm

- a) Secure the upper frame to the lower frame using the **4xM10x130mm Bolt [9]**, **8x10 Washers** and **M10 Nyloc Nuts [13]**.

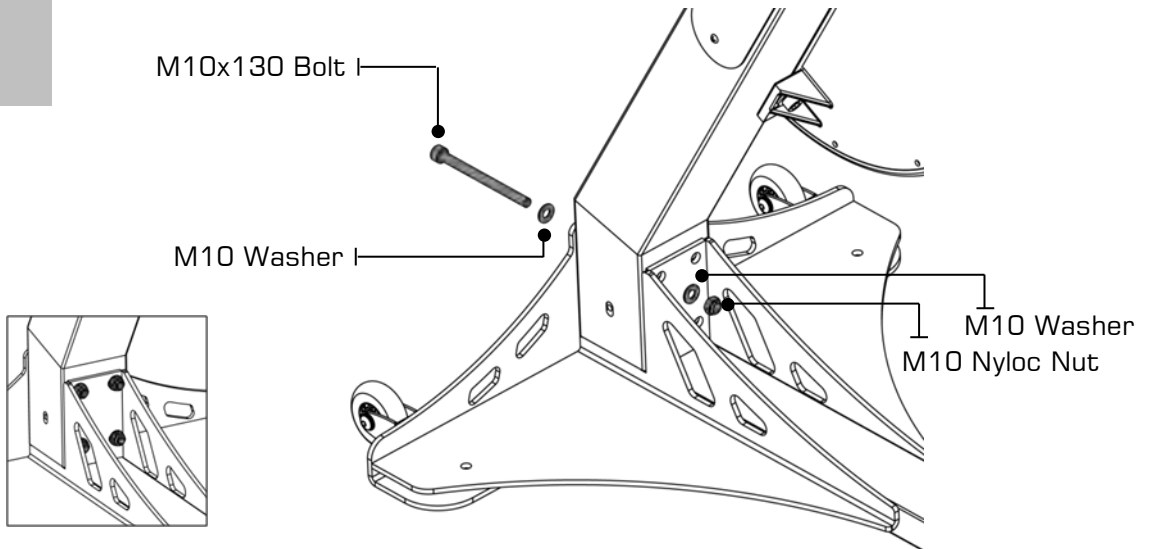

REQUIRED

2xM8x15mm [10]

2xM8 Washers [12]

6mm Allen Key [15]

Torque: 180Kgf.cm

- b) Secure either side of bracket using the **2xM8x15mm [10]** and **M8 Washers [12]**, tightening with the **6mm Allen Key [15]**.

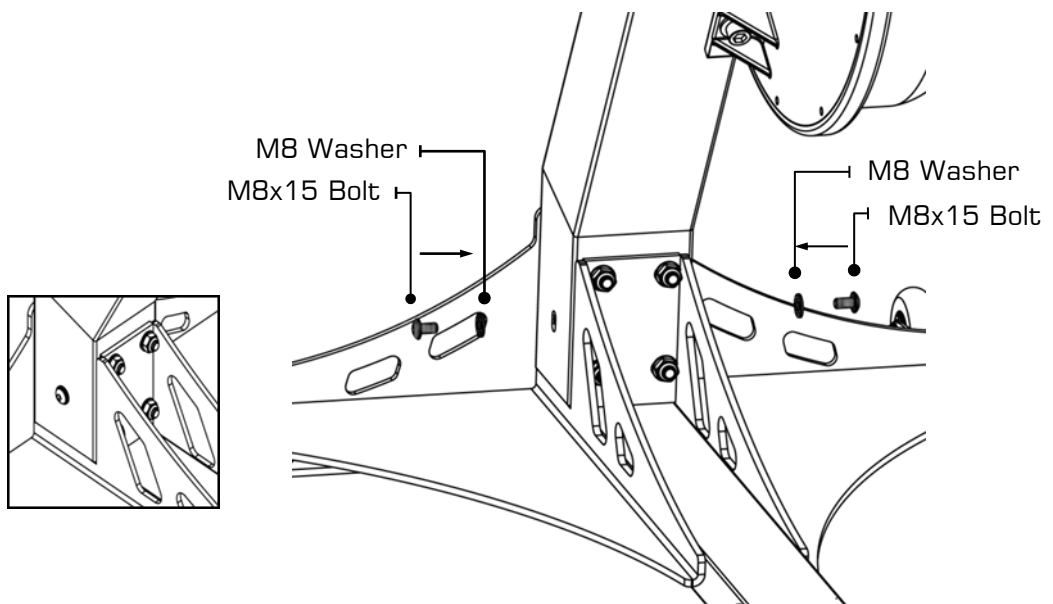

Assembly Instructions

STEP 3

ATTACH RIGHT AND LEFT HANDLES TO CRANK SHAFT

REQUIRED

- 1 x Left Handle Kit [3]
- 1 x Right Handle Kit [4]
- 2 x M15 Washer
- 2 x M8x15mm Bolt
- 6mm Allen Key [15]
- 15mm Spanner[17]

- Identify the right and left handle shafts. There is a 'R' or 'L' marked on each handle shaft. **NOTE:** Improper installation will result in uneven handle adjustment.
- Use the 6mm Allen Key to disassemble the M8x15mm Bolt and M15 Washer on each handle.

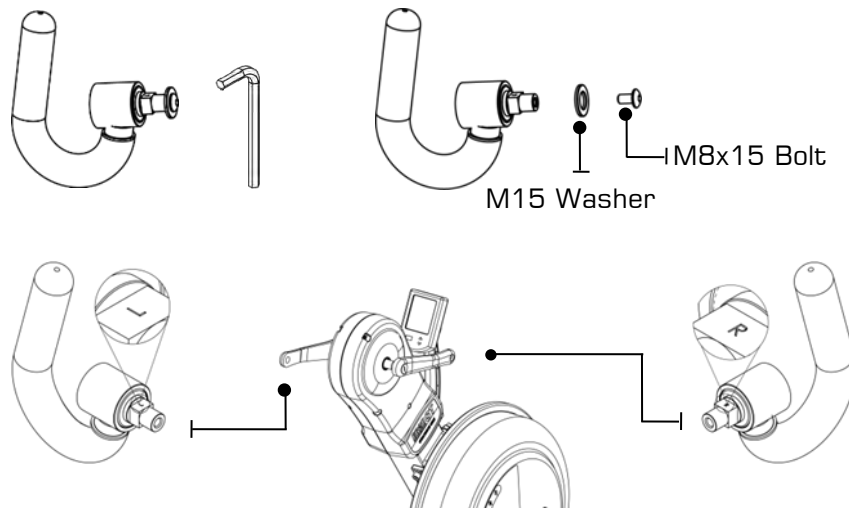

- Secure right and left handle onto corresponding crank arms by screwing the handle counter-clockwise using the 15mm Spanner [17]
- Re-assemble the M8 Bolt and M15 Washer onto the handle on each side using the 6mm Allen Key [15]

15mm Spanner

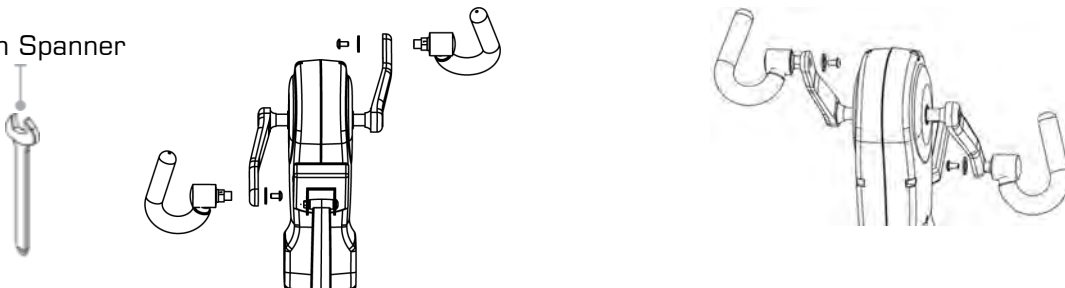

NOTE: Handle threads have a blue coating which will feel very tight when threaded onto crank arm. This is a type of thread locker, which once in contact with the crank arm will cause threads to activate. Note: Allow 15 minutes for the thread locker to activate before first time use. Check pedal tightness periodically thereafter with a 15mm wrench. **DO NOT USE IF NOT TIGHT.**

CAUTION! EXTREME OVER-TIGHTENING COULD DAMAGE THE ALUMINIUM THREADS ON THE CRANK ARM.

»» Operation Instructions

»» Tank Filling and Water Treatment

REQUIRED

Funnel and Hose[7]

! CAUTION

Use a drop cloth under the tank when filling to avoid damaging to floor or carpet.
Do not fill past the calibration mark as indicated on the tank level sticker or water spillage may occur.

! NOTE

In areas where tap water quality is known to be poor, FDF recommends the use of distilled water.

! WARNING

Impeller blades are sharp!
Do not Place fingers in tank to adjust impeller position.
It is recommended to use the end of the hose should the impeller require adjustment

- Filling requires a large bucket (not supplied) and the supplied water **Funnel and Hose[7]**. Filling will take approximately 8 liters of water.
- Open the yellow fill plug on the back of tank and insert hose (rotating the impeller slightly may be necessary to allow the hose to pass). **In areas where tap water quality is known to be poor, FDF recommends the use of distilled water.**
- Move the tank adjuster handle to level 10 and begin filling. Do not fill the tank higher than the level indicator on the front of the clear shell.
- Once filling is complete follow the water treatment schedule below.

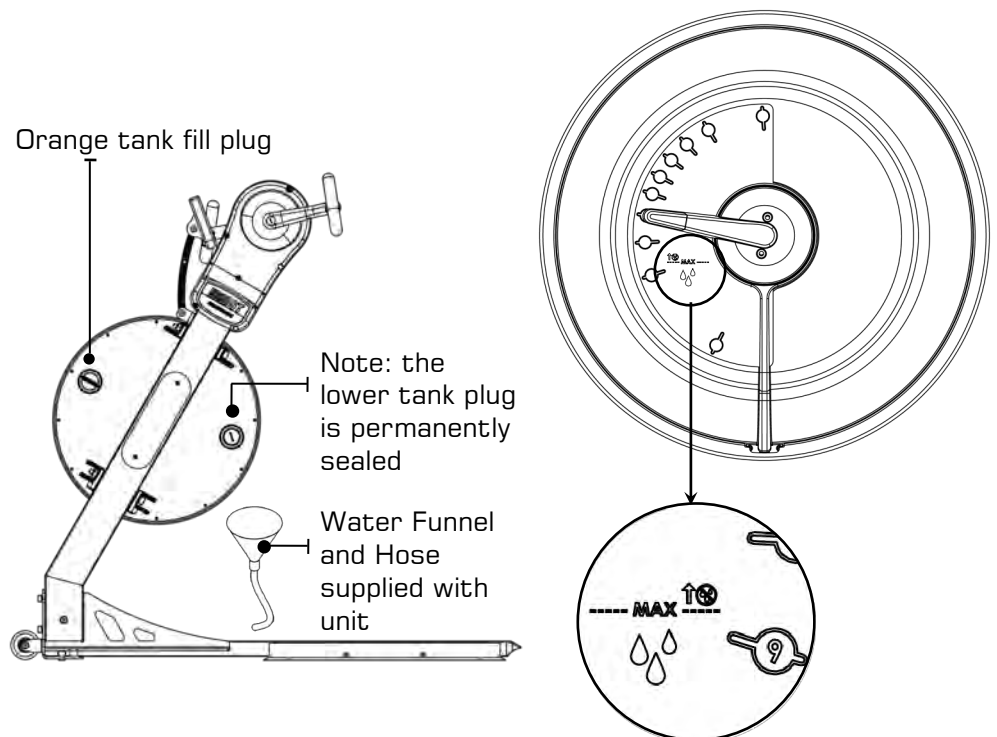

NOTE: For simple, fast and efficient filling and/or drainage of the Fluid Tank, we have a battery operated pump (rechargeable via USB) available as an option. We recommend this to any commercial facility, with multiple units, that has a need to drain and refill Tanks from time to time. To purchase, contact your nearest First Degree Fitness distributor or go to our website on www.firstdegreefitness.com for details.

INITIAL WATER TREATMENT

Add One Water Treatment Tablet per full tank. Do NOT, UNDER ANY CIRCUMSTANCE, USE A WATER TREATMENT TABLET OTHER THAN THOSE SUPPLIED WITH YOUR UNIT. Your unit purchase includes 4xWater Treatment Tablets, which is sufficient for several years of use.

To purchase additional Water Treatment Tablets, please consult your nearest regional dealer/distributor or check our website at www.firstdegreefitness.com

» Operation Instructions

CHANGING RESISTANCE LEVEL

Changing resistance on your POWER UBE is simple. The level of resistance is determined by the level indicator located on the side of tank. Level one indicates lightest resistance, level ten represents heaviest resistance. The tank's variable fluid resistance technology ensures an instant catch and constant resistance throughout the pedaling.

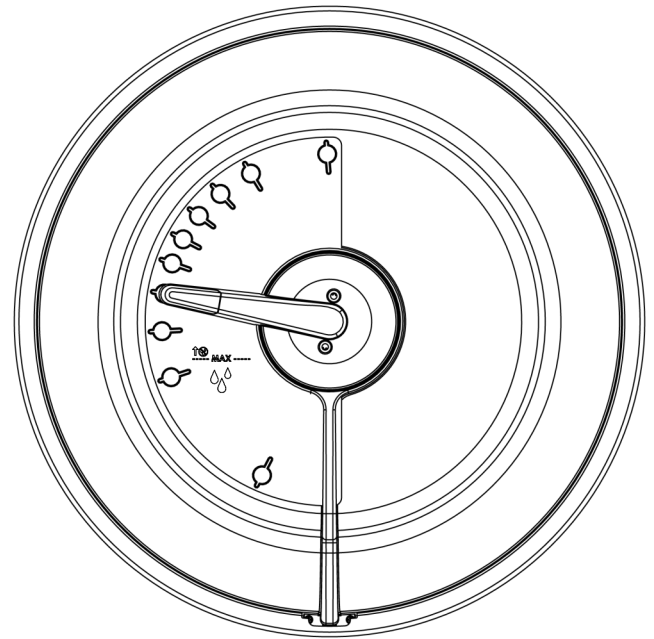

START CRANKING

- Stand on the foot plates with feet shoulder width apart (feet, hips and shoulders should be square to the machine).
- Grip ergonomic handles comfortably and commence rotating the cranks forward or backward.
- Stand close enough so that when either arm is at its furthest point away from you, your arm is comfortably extended and your shoulders are still square.
- If you are seeking a 'full body' workout, try applying pressure from your hips and feet to engage a fully integrated crank.
- To stop the crank action, gradually slow motion and apply tension in the opposite direction.

LONG-TERM WATER TREATMENT

WARNING: DO NOT USE ANY OTHER WATER TREATMENT TABLET OTHER THAN THOSE SUPPLIED WITH YOUR UNIT.

The amount of time between water treatments can vary greatly depending on your unit's location and exposure to sunlight. Typically you can expect to treat your tank water every 12-24 months. If water becomes discolored or shows signs of algae / bacterial growth simply add one Water Treatment Tablet.

» Bluetooth Auto-Adjust Monitor

Auto Start: Commence exercise to activate.

Reset all values: Press and hold RESET button for 3 seconds.

Auto Power Down: Over 5 minutes. All values revert to zero after restart.

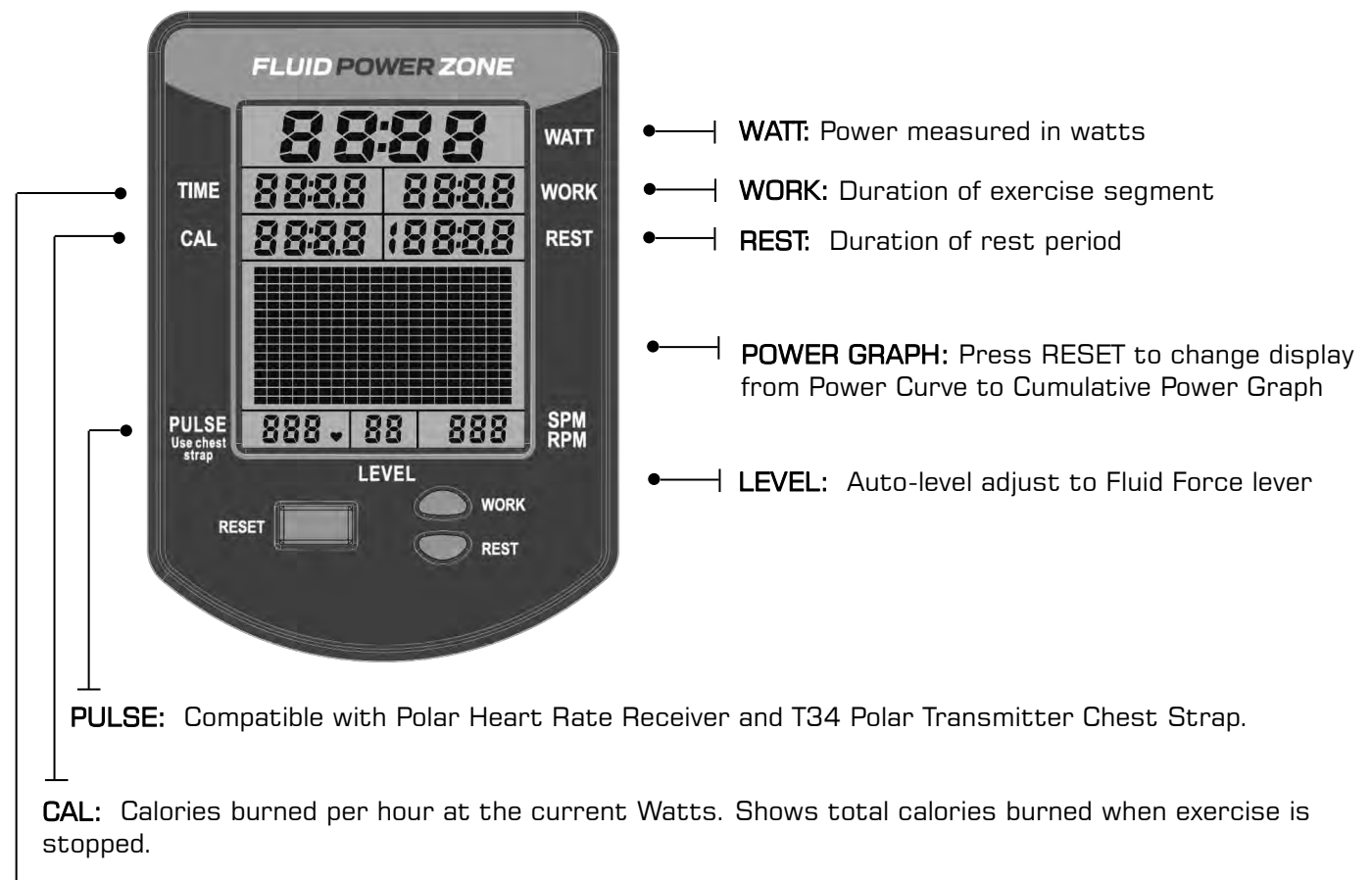

TIME: Auto start elapsed time.

WATT: Measures peak power in watts, calculating the strength and acceleration provided to accurately measure a user's power.

TRAINING DATA: Data gathered from each workout is displayed in a power curve and cumulative power graph, enabling real-time comparisons for effective progressive training.

AUTO ADJUST LEVEL: Built in potentiometer automatically adjusts the computer's resistance level according to the position of the Fluid Force Lever on the Tank .

BLUETOOTH CONNECTIVITY: Each Rower is fitted with the most advanced console technology, enabling Bluetooth connectivity with any compatible smart device. Designed to integrate with rowing and fitness apps, the console will assist with effective training progression, capturing and comparing data for the competitive individual. (Including FDF Power Zone APP available via FDF Website)

NOTE: T34 Polar Heart Rate Transmitter Chest Strap is sold separately.

 WARNING:	<p>Heart rate monitoring systems may be inaccurate, Over exercising may result in serious injury or death. If you feel faint stop exercising immediately and seek professional medical advice.</p>
--	--

» Calibration Procedure

STEP 1

Press and hold 「RESET」 and 「REST」 for 5 seconds.
Display will show LEVEL " 1 "

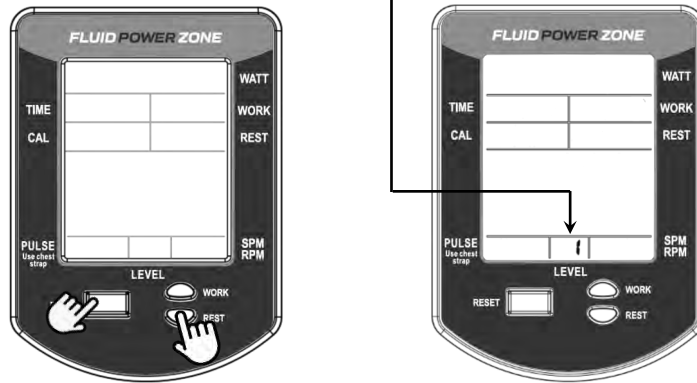

STEP 2

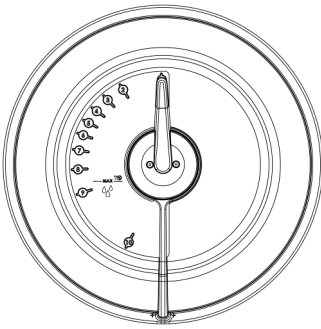

Turn handle to Level 1.
Press Reset.
Display will now show Level 2.
Level 1 Calibration is complete.

STEP 3

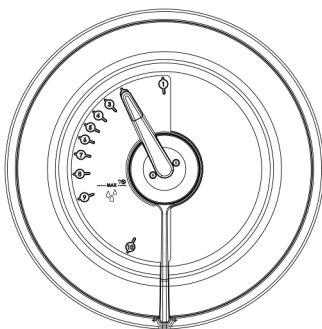

Turn handle to Level 2.
Press Reset.
Display will now show Level 3.
Level 2 Calibration is complete.

STEP 4

Repeat for 3,4,5,6,7,8,9,10. Level 10
Press Reset.

Calibration is complete.

» Maintenance & Troubleshooting

For further information, manuals and warranty requests visit
www.firstdegreefitness.com/support

Problem	Solution
Water changer color or becomes cloudy.	Change rower location to reduce direct exposure to sunlight. Add water treatment or change tank water as directed in the water treatment section of this manual. Consider using distilled water to refill tank.
I want to drain the fluid tank on my POWER UBE.	It is recommended to take your unit outdoors, open the Orange fill plug, and lay unit on its back to facilitate draining process. For simple, fast and efficient filling and/or drainage of the Fluid Tank, we have a battery operated pump (rechargeable via USB) available as an option. We recommend this to any commercial facility, with multiple units, that has a need to drain and refill Tanks from time to time. To purchase, contact your nearest First Degree Fitness distributor or go to our website on www.firstdegreefitness.com for details.
The computer display is erratic and illuminates, but does not register with movement.	It is possible that there is a loose connection. Check that the computer lead is connected properly to the unit. If connected properly check sensor gap. Contact your local dealer if this fails to address the problem.
The computer does not illuminate after battery installation.	Replace/reinstall batteries in correct position and try again. If the LCD screen fails to illuminate, try rotating the batteries slightly in the computer. If this fails, contact your local service center.
The Bluetooth Auto-Adjust Monitor LEVEL is not synchronized with the tank LEVEL	Bluetooth Auto-Adjust Monitor LEVEL needs to be recalibrated. Please refer to "Calibration Procedure" page 14 of this manual.

To ensure maximum lifespan and optimal performance follow these steps:

1. Keep your POWER UBE in a dry, clean climate controlled environment at room temperature.
2. Only treat water with FDF genuine Water Treatment Tablets. Refer to 'water treatment' section on page 11.
3. Periodically clean your machine with disinfectant, applied using a lint free cloth.
4. Wipe dust off the machine.
5. For information on how to service your machine visit
firstdegreefitness.com/support

FULL COMMERCIAL USE

This product is designed and constructed for use in any Health Club / Fitness Studio application. FIRST DEGREE FITNESS Limited warrants that the **POWER UBE (model PZ-UBE)**, purchased from an authorized agent and in its undamaged original packaging, is free from defects in materials and workmanship. FIRST DEGREE FITNESS Limited or its agent will, at their discretion, repair or replace parts that become defective within the warranty period, subject to the specific inclusions and exclusions below.

Metal Frame – 10 Year Limited Warranty

FIRST DEGREE FITNESS will repair or replace the Metal Main Frame of the Rower should it fail due to any defect in materials or workmanship within 10 years of the original purchase. Warranty does not apply to frame coating.

Polycarbonate Tank & Seals – 5 Year Limited Warranty

FIRST DEGREE FITNESS will repair or replace the polycarbonate tank or seals should they fail due to any defect in materials or workmanship within 5 years of the original purchase.

Mechanical Components (of a non-wearing nature) – 2 Year Limited Warranty

FIRST DEGREE FITNESS will repair or replace any mechanical component should it fail due to any defect in materials or workmanship within 2 years of the original purchase.

All Other Components (of a wearing nature) – 2 Year Limited Warranty

FIRST DEGREE FITNESS will repair or replace any component should it fail due to any defect in materials or workmanship within 2 years of the original purchase.

Specific Inclusions

- Hand grip assemblies
- All rubber components
- Computer & speed Sensor (excluding replaceable batteries)
- All drive belts & chains
- Crank arms
- All pulleys, rollers & bearings

General Exclusions

- Damage to the finish of any part of the machine
- Damage due to neglect, abuse, incorrect assembly or use of the machine
- Any charges for freight or customs clearance associated with the return or dispatch of parts
- Any damage to or loss of goods during transport of any kind
- Any labour cost associated with a warranty claim

General Conditions

- The serial number of the machine must be correctly registered with First Degree Fitness Limited or one of its appointed distributors
- FIRST DEGREE FITNESS Limited reserve the right to examine any part where replacement is claimed under warranty
- Warranty period applies only to the original purchaser from the date of purchase and is not transferable
- The product must be returned to your place of purchase in original packaging with transportation, insurance and associated charges paid for by you and risk of loss or damage assumed by you
- FIRST DEGREE FITNESS makes no other warranties except as stated here and expressly disclaims all warranties not stated in this warranty. Neither FIRST DEGREE FITNESS nor its associates shall be responsible for incidental or consequential damages
- Manufacturer's warranty automatically commences upon sale of the product to end user or upon the expiration of one (1) year from month of manufacture, whichever occurs first



FIRST DEGREE FITNESS
Fluid INNOVATION

FITNESS PRODUCTS INSPIRED BY REAL LIFE

WWW.FIRSTDEGREEFITNESS.COM

CONTACT US

For customer support please visit
firstdegreefitness.com/support

TAIWAN

T: +886 3 478 3306
764 Chung Shan South Rd
Yangmei Taoyuan
Taiwan R.O.C.