

FIRST DEGREE FITNESS
Fluid INNOVATION

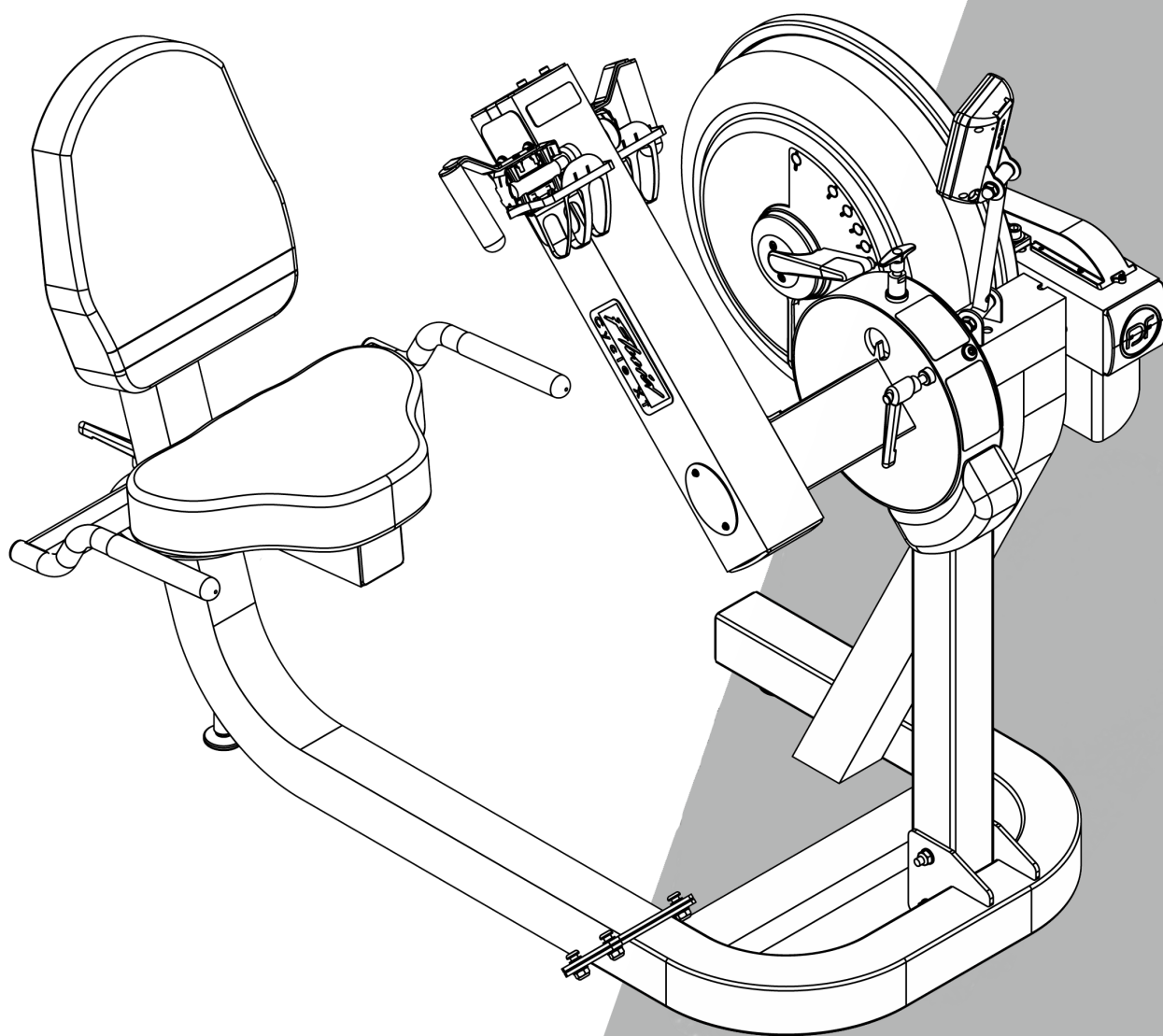

» USER GUIDE

E720A



REGISTER YOUR PRODUCT AT WWW.FIRSTDEGREEFITNESS.COM/SUPPORT

» Introduction

» Training with the E720A

Congratulations on your purchase of E720A.

FIRST DEGREE FITNESS is proud to present the Unit as a full commercial use product featuring patented Adjustable Fluid Resistance.

As with any piece of fitness equipment, consult a physician before beginning your E720A exercise program.

Follow all instructions carefully for correct assembly, Tank filling, water treatment, service and safety.

Access to our world-wide distributor and service network is available at www.firstdegreefitness.com

Check contents to assure all parts are present and correct prior to assembly.

CAUTION

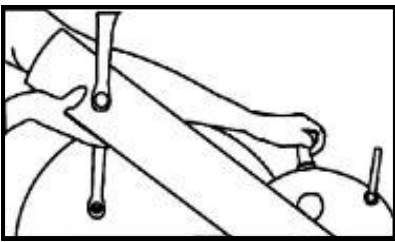

Use two hands and follow all safety instructions whenever raising or lowering the E720A control arm.

Warning

Do not remove feet or hands while crank is in motion. The crank will continue to rotate and could cause injury.

» Contents

Safety	5
Assembly	7
Box Contents.....	8
Assembly Instructions	9
Operation Instructions.....	11
Bluetooth Auto-Adjust Monitor.....	14
Calibration Procedure	15
Maintenance & Troubleshooting.....	16
Tank Belt Adjustment.....	18
International Warranty.....	19

Safety Information

- Before using this product, it is essential to read this ENTIRE operation manual and ALL instructions. The Unit is intended for use solely in the manner described in this manual.
- UNDERSTANDING EACH AND EVERY WARNING TO THE FULLEST IS IMPORTANT
- As with any piece of fitness equipment, consult a physician before beginning your Unit exercise program.
- Please be aware that any fitness regiment, before being undertaken, is best preceded by a physical checkup from a certified physician.
- Injuries to health may result from incorrect or excessive training.
-  **WARNING** Heart rate monitoring systems may be inaccurate. Over exercise may result in serious injury or death. If you feel faint, stop exercising immediately.
- Do not allow children unattended access to the machine.
- Please keep hands away from moving parts, as indicated by the warning label on the Main Frame of your machine.
- If any of the adjustment devices are left projecting, they could interfere with the user's movement.
- Do not store in freezing conditions with water in the Tank as it can expand and crack the components.

Installation

- Place on a stable, flat surface in a horizontal position during use for maximum stability.
- Check regularly and follow all instructions for maintenance as specified in this manual.
- Replace immediately any defective parts and do not operate unit until all repairs are complete.

Proper Usage

- Do not use any equipment in any way other than designed or intended by the manufacturer. It is imperative that FIRST DEGREE FITNESS equipment is used properly to avoid injury.
- Injuries may result if exercising improperly or excessively. It is recommended that all individuals consult a physician prior to commencing an exercise program. If at any time during exercise you feel faint, dizzy or experience pain, STOP EXERCISING and consult your physician.
- Keep body parts (hands, feet, hair, etc.), clothing and jewelry away from moving parts to avoid injury.
- Follow instructions provided in this manual for correct foot position and basic rowing techniques.
- For more detailed rowing techniques, please refer to our International website www.firstdegreefitness.com

Inspection

- DO NOT use or permit use of any equipment that is damaged and/or has worn or broken parts. For all FIRST DEGREE FITNESS equipment use only replacement parts supplied by FIRST DEGREE FITNESS.
- EQUIPMENT MAINTENANCE - Preventative maintenance is the key to smooth operating equipment as well as to keep your liability to a minimum. Equipment needs to be inspected at regular intervals.
- Ensure that any person(s) making adjustments or performing maintenance or repair of any kind is qualified to do so.
- DO NOT ATTEMPT TO USE OR REPAIR ANY ACCESSORY APPROVED FOR USE WITH THE FIRST DEGREE FITNESS EQUIPMENT WHICH APPEARS TO BE DAMAGED OR WORN.
- Check regularly and follow all instructions for maintenance as specified in this manual.
- Replace immediately any defective parts and do not operate unit until all repairs are complete.

Operating Warnings

- Keep children away from the equipment. Parents or others supervising children must provide close supervision of children if the equipment is used in the presence of children.
- Do not allow users to wear loose fitting clothing or jewelry while using equipment. It is also recommended to have users secure long hair back and up to avoid contact with moving parts.
- All bystanders must stay clear of all users, moving parts and attached accessories and components while machine is in operation.



- **WARNING** Do not insert fingers into Tank!

» Assembly

Product Specifications

Product Class: SC

Braking System: Speed Independent

Product Net Weight: 101.4kg (223.5lb)

Product Gross Weight: 120.8kg (266.3lb)

Maximum Safe Operating Surface Area: 253cm (99.61") Length x 217cm (85.43") Width

Dimensions: 1330mm (52.36") Length x 970mm (38.19") Width x 1520mm (59.84") Height

Maximum User Weight: 150kg (330lb)

Footprint: 1930mm x 1570mm or upright 1520mm x 970mm

Product Highlights

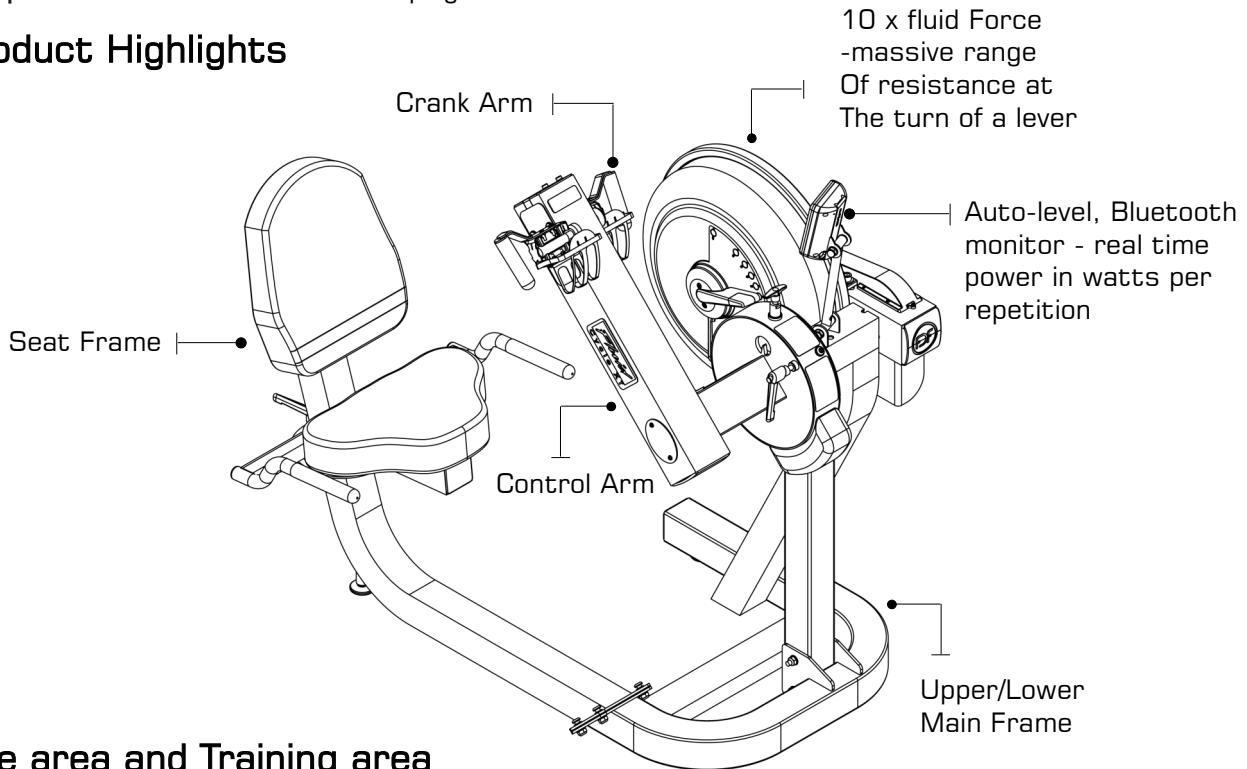

Live area and Training area

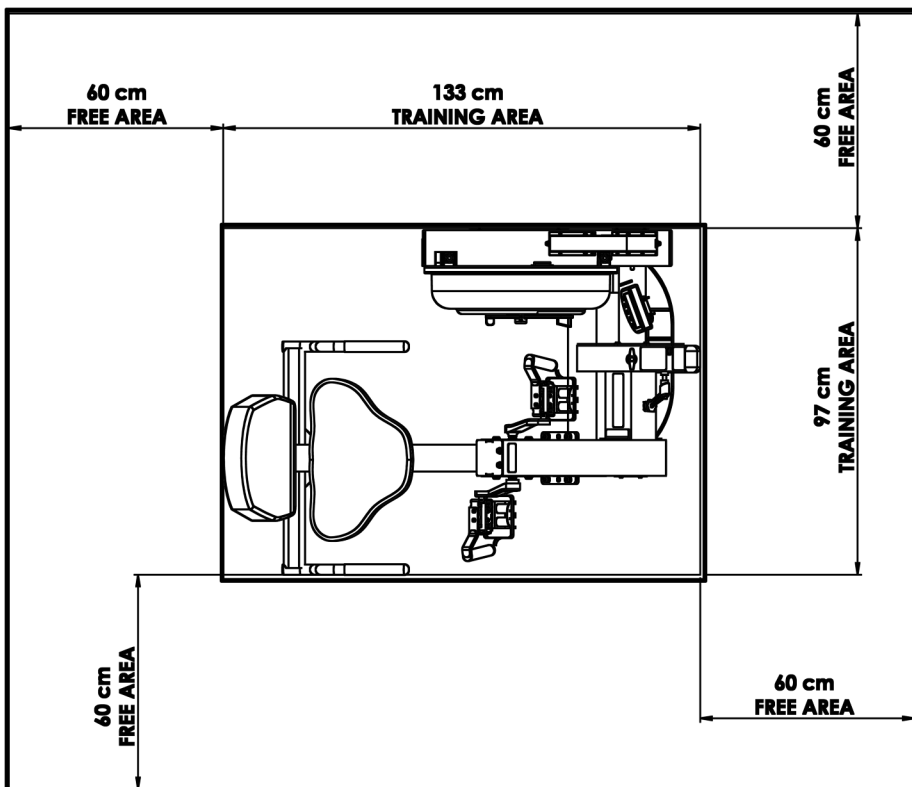

» Box Contents

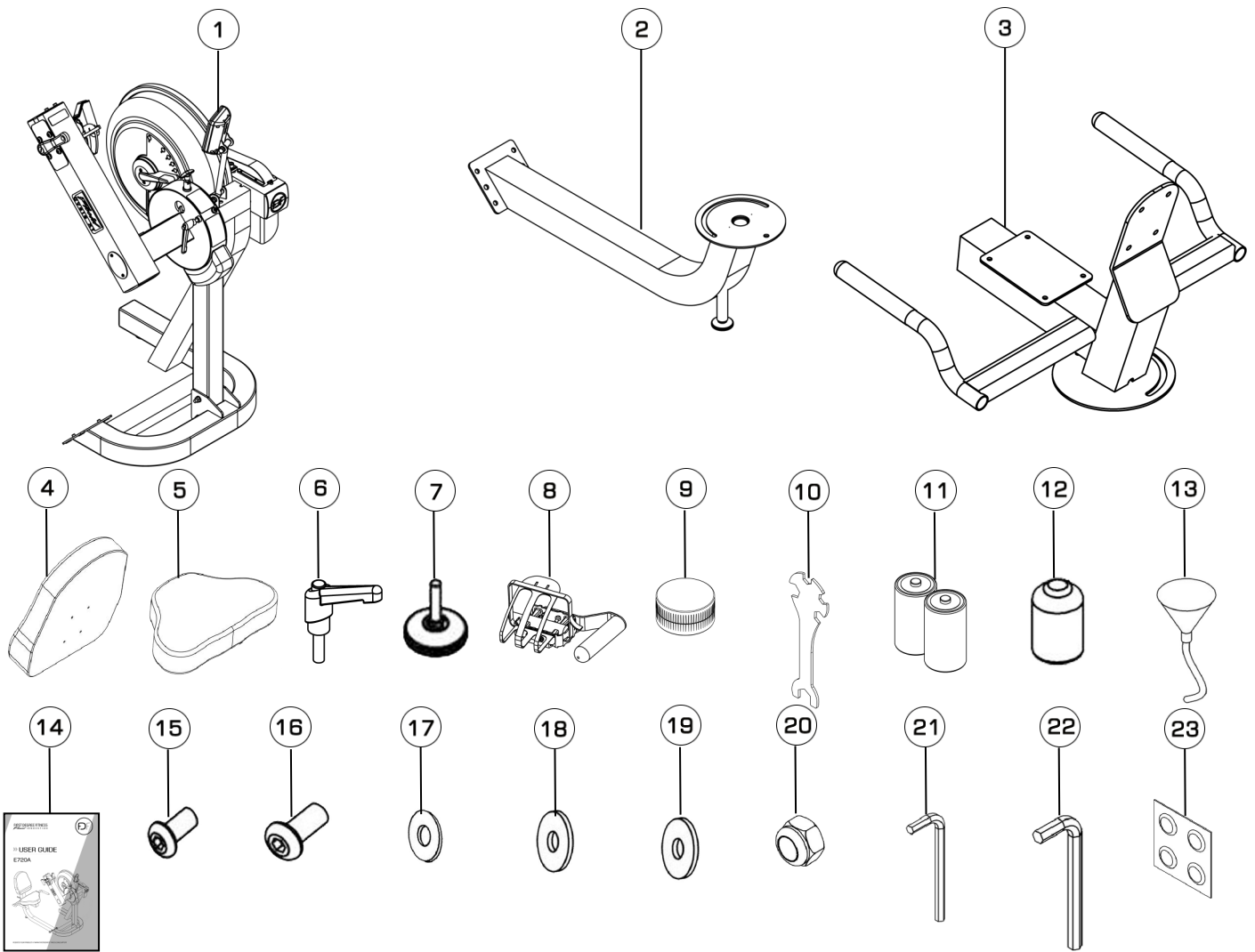

Item	Qty.	Description	Item	Qty.	Description
1	1	Main Frame	8	1	Right Crank Pedal
2	1	Lower Seat Frame	9	1	Seat Frame lubricating grease
3	1	Upper Seat Frame	10	1	Multi-Tool
4	1	Seat Back	11	2	D Cell Duracell Battery
5	1	Lower Seat	12	1	Touch Up Paint
6	1	L-pin	13	1	Funnel and Hose
7	3	Leveler	14	1	Owners Manual
Hardware KIT					
15	8	M6x20mm Bolt	20	5	M10 Nylock Nut
16	5	M10x25mm Bolt	21	1	4mm Allen Key
17	8	M6 Washer	22	1	6mm Allen Key
18	10	M10 Washer	23	4	Water Treatment Tablet
19	1	M10 Plastic Washer			

Assembly Instructions

STEP 1 Assembly Seat Back and Lower Seat

REQUIRED

Upper Seat Frame [3]

Seat Back [4]

Lower Seat [5]

8 x M6 x 20mm Bolts [15]

8 x M6 Washers [17]

- Seat Back[4] to Upper Seat Frame[3] using 4x M6x20mm Bolts[15] and 4x M6 Washers[17].
- Lower Seat[5] to Upper Seat Frame[3] using 4x M6x20mm Bolts[15] and 4x M6 Washers[17].

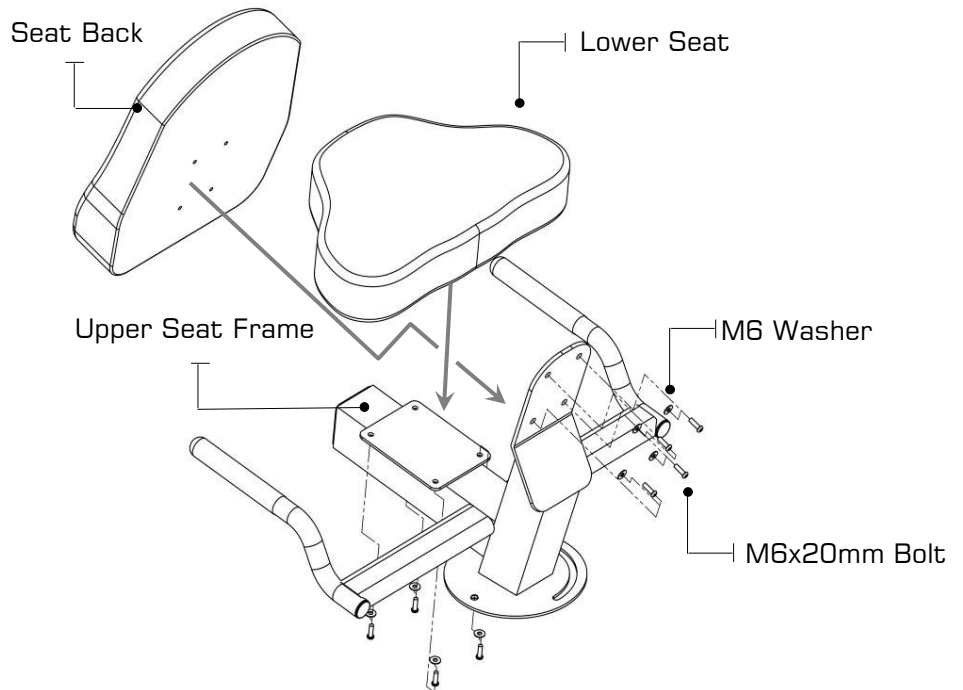

STEP 2 Assembly Main Frame and Lower Seat Frame

REQUIRED

Main Frame [1]

Lower Seat Frame [2]

3 x Foot Levelers [7]

4 x M10 x 25mm Bolts [16]

8 x M10 Washers [18]

4 x M10 Nyloc Nuts [20]

- Attach Lower Seat Frame[2] to Main Frame[1] using 4x M10x25mm Bolts[16], 4x M10 Nyloc Nuts[20] and 8x M10 Washers[18].
- Thread the 3x Foot levelers[7] into underside of base. Adjust as required.

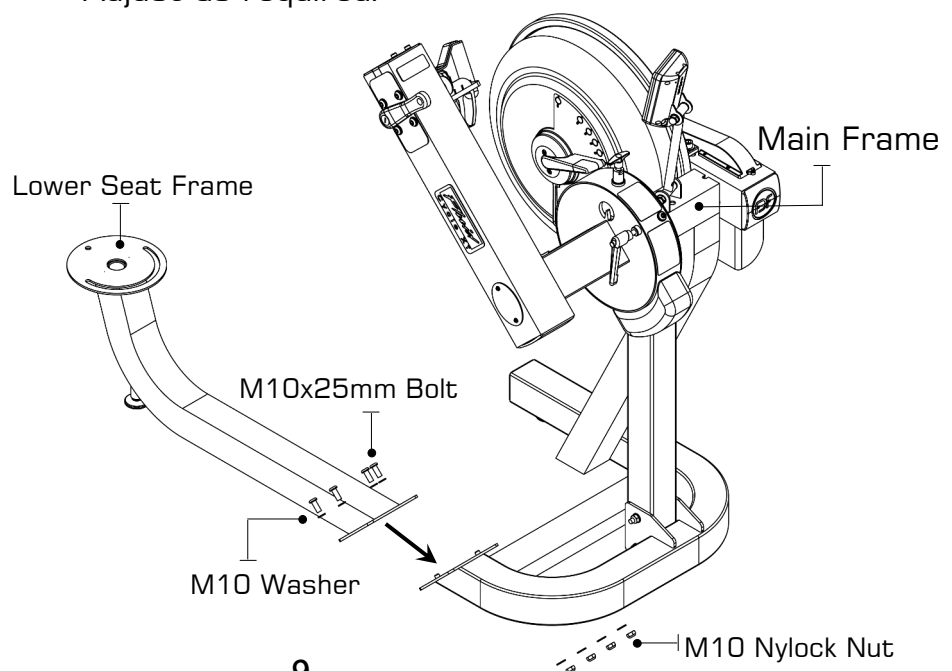

» Assembly Instructions

STEP 3 Assembly Upper Seat Frame and Lower Seat Frame

REQUIRED

Main Frame [1]
Upper Seat Frame [3]
L- Pin [6]
M10 x 25mm Bolts [16]
2 x M10 Washers [18]
M10 Plastic Washers [19]
M10 Nyloc Nuts [20]

Note: Tighten the M10x25mm Bolt, Washers and Nyloc until lightly snug only. Over-tightening will prevent the seat from rotating. Use the L-pin to tighten the Upper Seat Frame once rotated into place.

Upper Seat Frame[3] onto Main Frame[1] and secure using 1x M10x25mm Bolt[16], 1x M10 Nyloc Nut[20], 2xM10 Washers [18], M10 Plastic Washer[19] and L-pin[6].

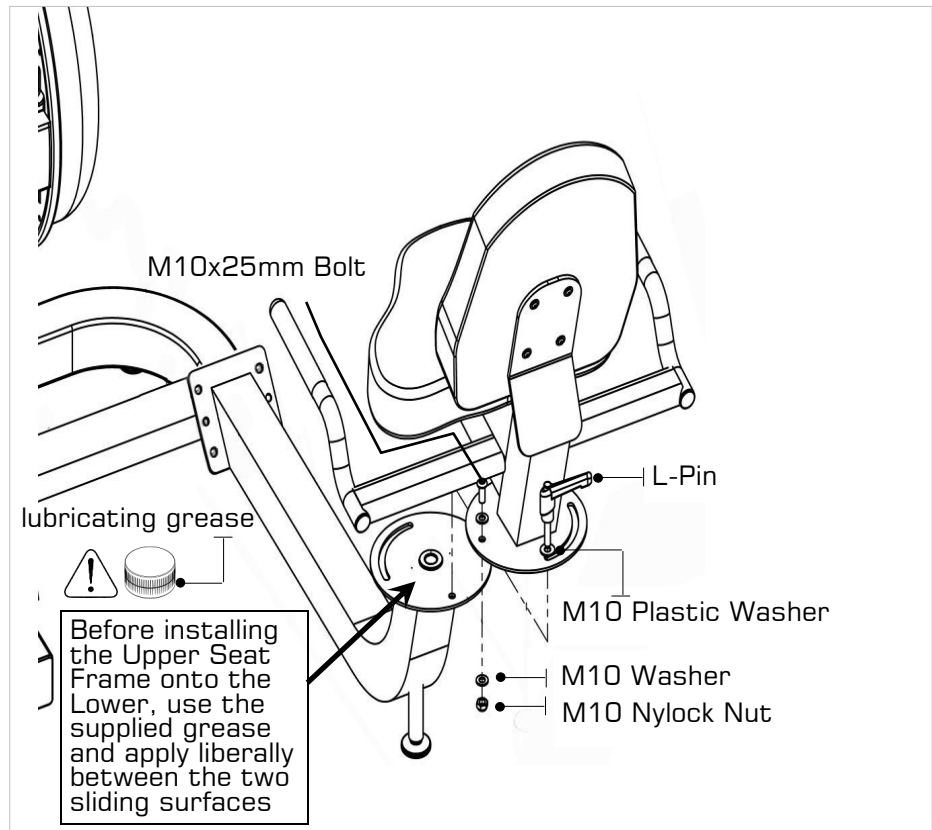

STEP 4 Assembly Right Crank Pedal

REQUIRED

Right Crank Pedal [8]

! CAUTION

Extreme over-tightening could damage the aluminum threads on the crank arm

Note: Allow 15 minutes for the thread-locker to activate before first time use. Check pedal tightness on a regular basis and tighten as needed with a 15mm wrench.

Secure **Right Crank Pedal**[8] onto Crank arm. The pedal threads have a blue coating which will feel very tight when threaded onto the crank arm. This is a type of thread locker, and once in contact with the crank arm threads will activate in approximately 15minutes.

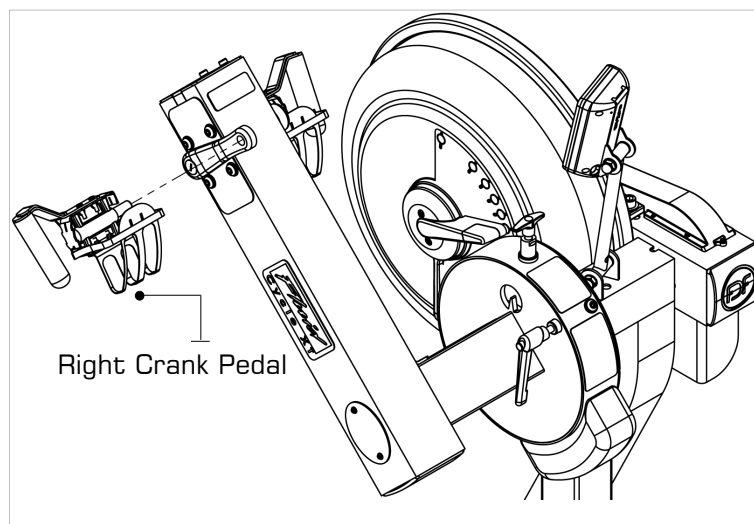

»» Operation Instructions

»» E720 Control Arm

Chain Tensioning Bolts: Allows for tightening the chain or adjustment from side to side. Make sure when tightening only to adjust the same amount for both Bolts, otherwise the sprocket will be misaligned.

Note: Tightening the right Bolt only will pull the right side of the crank assembly toward you, tightening the left will pull the left side toward you. Use this feature to realign the rear with the front sprocket if needed or when changing to a new chain.

Crank Arm Bolts: Loosen all 8 Bolts slightly before adjusting/tightening chain.

The E720A Pedal: This patented design allows for usage in both the recumbent position and for sitting/standing upper body workouts.

Inspection plate: Open to check chain tension.



Warning: Do not check chain tension by hand!

T-Pin: The T-pin locks the control arm in any one of 72 different positions throughout its 360 degree range of motion. Pull up the T-pin to allow the control arm to rotate while supporting the control arm with the other hand.

L-Pin: Loosen when rotating the control arm and tighten (snug only) once the desired position has been reached.

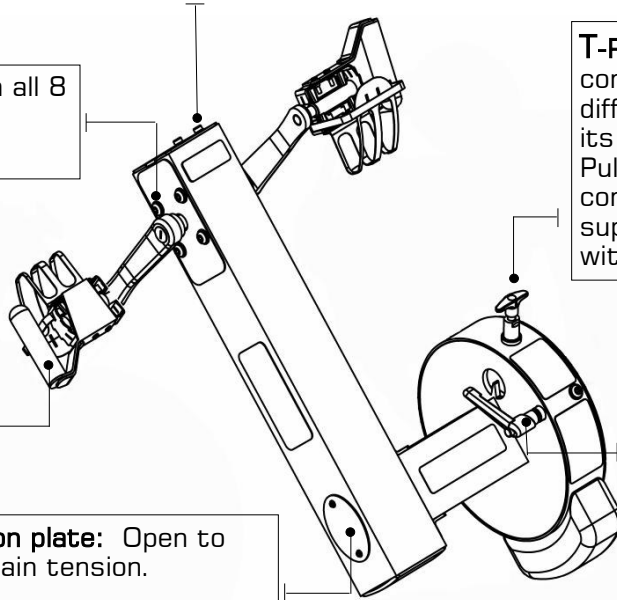

»» Operation Instructions

»» Tank Filling and Water Treatment

REQUIRED

Funnel and Hose[13]

! CAUTION

Use a drop cloth under the Tank when filling to avoid damaging to floor or carpet. Do not fill past the calibration mark as indicated on the Tank level sticker or water spillage may occur.

! CAUTION

In areas where tap water quality is known to be poor, FDF recommends the use of distilled water.

! WARNING

Impeller blades are sharp! Do not Place fingers in Tank to adjust impeller position. It is recommended to use the end of the hose should the impeller require adjustment

- Filling requires a large bucket (not supplied) and the supplied water **Funnel and Hose[13]**. Filling will take approximately 8 liters of water.
- Open the yellow fill plug on the back of Tank and insert hose (rotating the impeller slightly may be necessary to allow the hose to pass). **In areas where tap water quality is known to be poor, FDF recommends the use of distilled water.**
- Move the Tank adjuster handle to level 10 and begin filling. Do not fill the Tank higher than the level indicator on the front of the clear shell.
- Once filling is complete follow the water treatment schedule below.

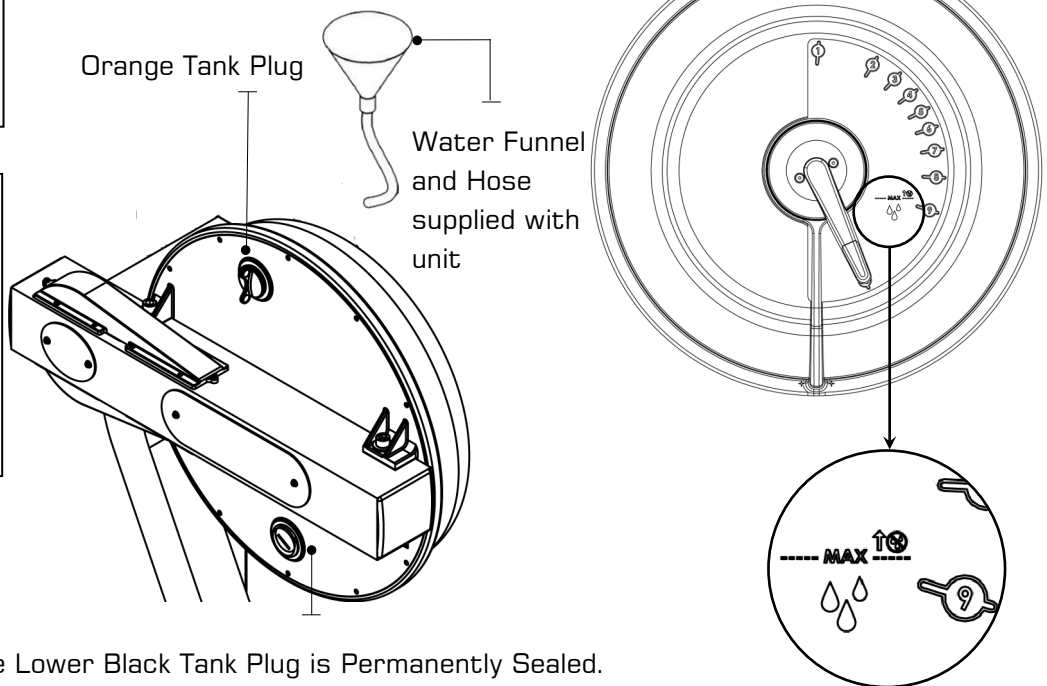

NOTE: For simple, fast and efficient filling and/or drainage of the Fluid Tank, we have a battery operated pump (rechargeable via USB) available as an option. We recommend this to any commercial facility, with multiple units, that has a need to drain and refill Tanks from time to time. To purchase, contact your nearest First Degree Fitness distributor or go to our website on www.firstdegreefitness.com for details.

INITIAL WATER TREATMENT

Add One Water Treatment Tablet per full Tank. Do NOT, UNDER ANY CIRCUMSTANCE, USE A WATER TREATMENT TABLET OTHER THAN THOSE SUPPLIED WITH YOUR UNIT. Your unit purchase includes 4xWater Treatment Tablets, which is sufficient for several years of use.

To purchase additional Water Treatment Tablets, please consult your nearest regional dealer/distributor or check our website at www.firstdegreefitness.com

»» Operation Instructions

CHANGING RESISTANCE LEVEL

Changing resistance on your Unit is simple. The level of resistance is determined by the level indicator located on the front of the Tank. Level one indicates lightest resistance, level ten represents heaviest resistance. The Tank's variable fluid resistance technology ensures an instant catch and constant resistance throughout the movement.

Your Unit computer will automatically adjust to the resistance level selected on the Tank. Allow three to four seconds after adjusting resistance handle for the correct resistance level to be achieved.

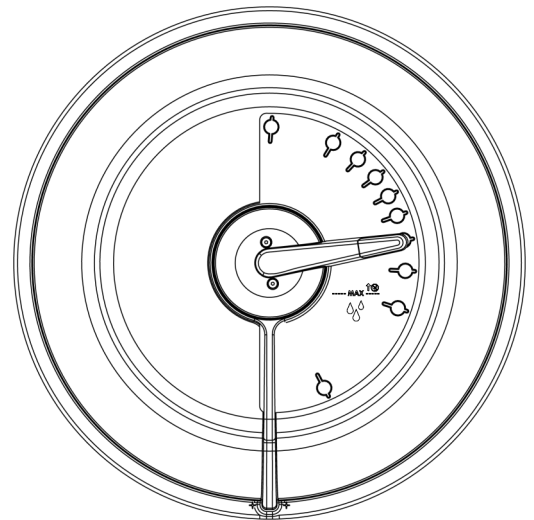

LONG-TERM WATER TREATMENT

WARNING: DO NOT USE ANY OTHER WATER TREATMENT TABLET OTHER THAN THOSE SUPPLIED WITH YOUR UNIT.

The amount of time between water treatments can vary greatly depending on your unit's location and exposure to sunlight. Typically you can expect to treat your Tank water every 12-24 months. If water becomes discolored or shows signs of algae / bacterial growth simply add one Water Treatment Tablet.

» Bluetooth Auto-Adjust Monitor

Auto Start: Commence exercise to activate.

Reset all values: Press and hold RESET button for 3 seconds.

Auto Power Down: Over 5 minutes. All values revert to zero after restart.



- | **WATT:** Power measured in watts
- | **WORK:** Duration of exercise segment
- | **REST:** Duration of rest period
- | **POWER GRAPH:** Press RESET to change display from Power Curve to Cumulative Power Graph
- | **LEVEL:** Auto-level adjust to Fluid Force lever

PULSE: Compatible with Polar Heart Rate Receiver and Transmitter Chest Strap.

CAL: Calories burned per hour at the current Watts. Shows total calories burned when exercise is stopped.

TIME: Auto start elapsed time.

WATT: Measures peak power in watts, calculating the strength and acceleration provided to accurately measure a user's power.

TRAINING DATA: Data gathered from each workout is displayed in a power curve and cumulative power graph, enabling real-time comparisons for effective progressive training.

AUTO ADJUST LEVEL: Built in potentiometer automatically adjusts the computer's resistance level according to the position of the Fluid Force Lever on the Tank .

BLUETOOTH CONNECTIVITY: Each Unit is fitted with the most advanced console technology, enabling Bluetooth connectivity with any compatible smart device. Designed to integrate with rowing and fitness apps, the console will assist with effective training progression, capturing and comparing data for the competitive individual. (Including FDF Power Zone APP available via FDF Website)

NOTE: Heart Rate Transmitter Chest Strap is sold separately.

 WARNING:	<p>Heart rate monitoring systems may be inaccurate, Over exercising may result in serious injury or death. If you feel faint stop exercising immediately and seek professional medical advice.</p>
--	--

» Calibration Procedure

STEP 1

Press and hold 「RESET」 and 「REST」 for 5 seconds.
Display will show “ - - - - ”

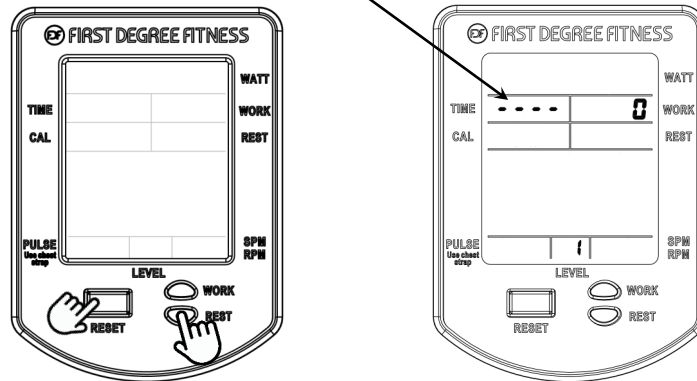

STEP 2

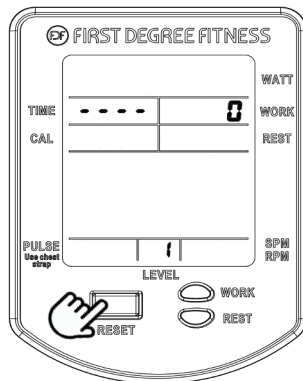
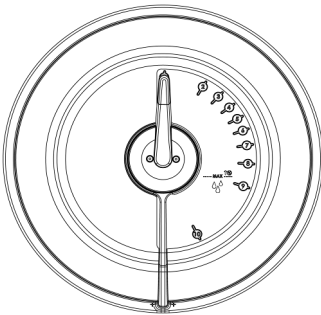

Turn handle to Level 1.
Press Reset.
Display will now show Level 2.
Level 1 Calibration is complete.

STEP 3

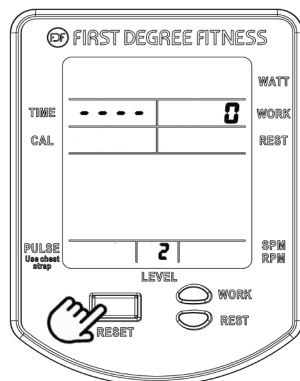
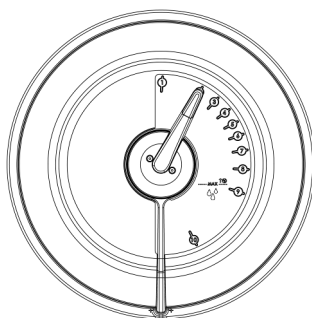

Turn handle to Level 2.
Press Reset.
Display will now show Level 3.
Level 2 Calibration is complete.

STEP 4

Repeat for 3,4,5,6,7,8,9,10. Level 10
Press Reset.

Repeat the steps back to level 1.

Calibration is complete.

» Maintenance & Troubleshooting

For further information, manuals and warranty requests visit
www.firstdegreefitness.com/support

Problem	Solution
Water changer color or becomes cloudy.	Change Unit location to reduce direct exposure to sunlight. Add water treatment or change Tank water as directed in the water treatment section of this manual. Consider using distilled water to refill Tank.
I want to drain the fluid Tank on my E720A.	It is recommended to take your unit outdoors, open the Orange fill plug, and lay unit on its back to facilitate draining process. For simple, fast and efficient filling and/or drainage of the Fluid Tank, we have a battery operated pump (rechargeable via USB) available as an option. We recommend this to any commercial facility, with multiple units, that has a need to drain and refill Tanks from time to time. To purchase, contact your nearest First Degree Fitness distributor or go to our website on www.firstdegreefitness.com for details.
The computer display is erratic and illuminates, but does not register with movement.	It is possible that there is a loose connection. Check that the computer lead is connected properly to the unit. If connected properly check Sensor gap. Contact your local dealer if this fails to address the problem.
The computer does not illuminate after battery installation.	Replace/reinstall batteries in correct position and try again. If the LCD screen fails to illuminate, try rotating the batteries slightly in the computer. If this fails, contact your local service center.
The Bluetooth Auto-Adjust Monitor LEVEL is not synchronized with the Tank LEVEL.	Bluetooth Auto-Adjust Monitor LEVEL needs to be recalibrated. Please refer to "Calibration Procedure" page 15 of this manual.
Knocking noise from inside the control arm while training, especially when changing directions Chain requires tightening or adjustment.	Open inspection plate located on front of control arm and check tension using a screwdriver or other tool. Use the chain tensioning Bolts located at the rear of the control arm to tighten or adjust as needed. The chain should have approx. 3mm of slack when properly adjusted. See P.11 for details.
Pedal is loose (either left or right) and cannot be retightened. Aluminum crank arm threads are stripped.	Contact service center for replacement. Then check weekly as recommended.
Pedals slip during hard training. PK Tank belt requires tightening.	Remove large inspection plate next to the Tank, insert a long tool to push the rear end cap out from the inside, exposing the Tank belt tensioning Bolt. Loosen Tank Bolts slightly. Remove upper rubber belt cover to expose the PK belt. Tighten the Tank tensioning Bolt until the belt is too tight to be twisted from side to side more than 45 degrees by hand.

» Maintenance & Troubleshooting

Item	Time Frame	Instructions
Seat and Frame.	Weekly.	Wipe down weekly with lint free cloth or more often with heavy club use.
PK Belt Tension.	Monthly.	Check monthly for signs of slippage. Adjust/tighten as required.
Tank and Water Treatment.	12 months to 2 years.	Follow instructions as specified in the "Water Treatment" section of this manual.
Chain Drive.	Check every 100 hours for correct tension.	Open the inspection plate and check tension using a screwdriver or other tool. Tighten as required using chain tensioning Bolts located at the end of the control arm.
Handle Assembly.	Check weekly using Multi-Tool (supplied) to ensure Handle Assembly is securely tightened into Crank Arm.	The handle should be checked on a regular basis. Continued use of a loose Handgrip can cause damage to the Crank Arm threads, necessitating replacement.

To ensure maximum lifespan and optimal performance follow these steps:

1. Keep your E720A in a dry, clean climate controlled environment at room temperature.
2. Only treat water with FDF genuine Water Treatment Tablets. Refer to 'water treatment' section on page 12.
3. Periodically clean your machine with disinfectant, applied using a lint free cloth.
4. Wipe dust off the machine.
5. For information on how to service your machine visit firstdegreefitness.com/support

» Tank Belt Adjustment

1. Remove large metal inspection plate.

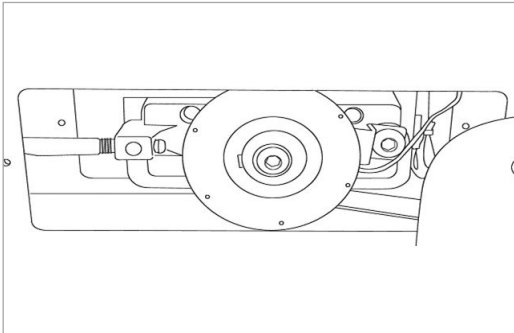

2. Using a long tool, push out the rear end cap as pictured below left. This will give you access to the Tank tensioning Bolt (shown lower right).

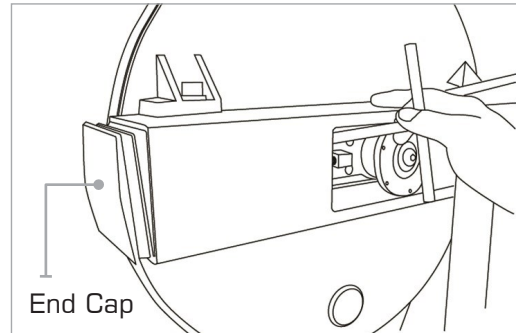

3. Loosen both the rear and front Tank Bolts slightly as shown. Remove front Rubber Belt Cover.

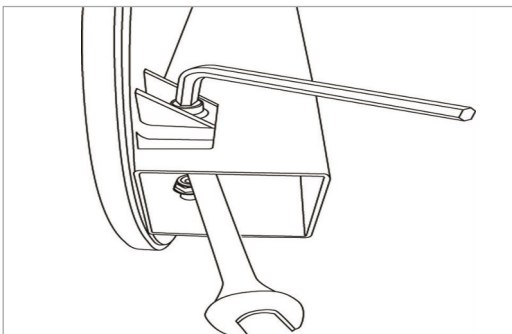

4. Using a 6mm Allen Key, tighten the Belt using the Tank Tensioning Bolt until the belt no longer slips during hard rowing.

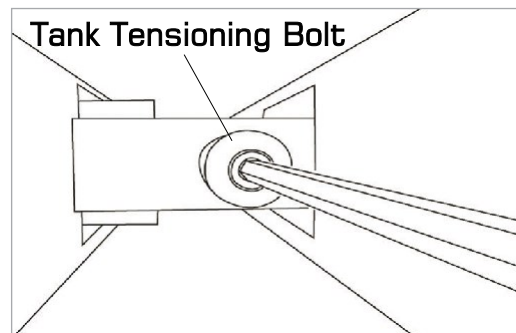

Note: Do not over tighten Tank Bolts.

Tip: Twist the Belt by hand to gauge tightness. Correct tension should be obtained when no longer able to twist more than 45 degrees

FULL COMMERCIAL USE

This product is designed and constructed for use in any Health Club / Fitness Studio application.

First Degree Fitness Limited warrants that the **E720A Cycle XT (model E720A)**, purchased from an authorized agent and in its undamaged original packaging, is free from defects in materials and workmanship. First Degree Fitness Limited or its agent will, at their discretion, repair or replace parts that become defective within the warranty period, subject to the specific inclusions and exclusions below.

Metal Frame – 10 Year Limited Warranty

First Degree Fitness will repair or replace the metal Main Frame should it fail due to any defect in materials or workmanship within 10 years of the original purchase. Warranty does not apply to frame coating.

Polycarbonate Tank & Seals – 5 Year Limited Warranty

First Degree Fitness will repair or replace the polycarbonate Tank or seals should they fail due to any defect in materials or workmanship within 5 years of the original purchase.

Mechanical Components (of a non-wearing nature) – 2 Year Limited Warranty

First Degree Fitness will repair or replace any mechanical component should it fail due to any defect in materials or workmanship within 2 years of the original purchase.

All Other Components (of a wearing nature) – 2 Year Limited Warranty

First Degree Fitness will repair or replace any component should it fail due to any defect in materials or workmanship within 2 year of the original purchase.

Specific Inclusions

- Pedals & toe straps
- Hand grip assemblies
- Seat
- All rubber components
- Computer & speed Sensor (excluding replaceable batteries)
- All drive belts & chains
- Crank arms
- All pulleys, rollers & bearings

General Exclusions

- Damage to the finish of any part of the machine
- Damage due to neglect, abuse, incorrect assembly or use of the machine
- Any charges for freight or customs clearance associated with the return or dispatch of parts
- Any damage to or loss of goods during transport of any kind
- Any labour cost associated with a warranty claim

General Conditions

- The serial number of the machine must be correctly registered with First Degree Fitness Limited or one of its appointed distributors
- First Degree Fitness Limited reserve the right to examine any part where replacement is claimed under warranty
- Warranty commences at time of sale but no later than six (6) months from date of original shipment
- Warranty period applies only to the original purchaser from the date of purchase and is not transferable
- The product must be returned to your place of purchase in original packaging with transportation, insurance and associated charges paid for by you and risk of loss or damage assumed by you
- First Degree Fitness makes no other warranties except as stated here and expressly disclaims all warranties not stated in this warranty. Neither First Degree Fitness nor its associates shall be responsible for incidental or consequential damages
- Manufacturer's warranty automatically commences upon sale of the product to end user or upon the expiration of one (1) year from month of manufacture, whichever occurs first



FIRST DEGREE FITNESS
Fluid INNOVATION

FITNESS PRODUCTS INSPIRED BY REAL LIFE

WWW.FIRSTDEGREEFITNESS.COM

NOUS CONTACTER

Pour le soutien à la clientèle, veuillez visiter firstdegreefitness.com/support

TAÏWAN

T: +886 3 478 3306
764 Chung Shan South Rd
Yangmei Taoyuan
Taiwan R.O.C.

