

VIKING 2 PLUS

RESIDENTIAL FLUIDROWER

The FDF Viking 2 Plus FluidRower is a sleek and modern rower designed for casual cardio or high-intensity training. This Viking 2 Plus features a durable, sturdy constructed frame from ethically sourced American Ash woodgrain.

The Viking 2 Plus has 4 levels of adjustable Fluid Resistance provided by our patented Twin Tank system. Manually adjust the resistance by turning a tactile and audible selector dial, assuring accurate and even level selection.

The 4 levels of Adjustable Fluid Resistance provide a consistent resistance throughout the entire rowing stroke. The range of adjustability from level 1 "feather light" to level 4 for an intense workout.

Easy to stow-away, stand this model on its end for compact storage.

It is appealing to a broad market, including rehab and seniors. The Viking 2 Plus is also compatible with FDF's optional Seat Back Kit for extra lumbar support, and the Elevate Kit for easier on-off access.



FLUID ROWER



MINIMUM

MAXIMUM

AMERICAN ASH
WOOD FRAME

Industrial nylon belt for
smooth and quiet rowing

Multi-level monitor

Premium ergonomic
contoured handle

Transport
wheels

Height adjustable
footplate

Textured seat
to prevent slipping

Double sealed precision aligned
twin fluid resistance tank

Hand-lacquered American
Ash woodgrain frame

View the full range of rowers at [FLUIDROWER.COM](https://www.fluidrower.com)

Visit [FIRSTDEGREEFITNESS.COM](https://www.firstdegreefitness.com) to view all FDF product ranges.

VIKING 2 PLUS FLUIDROWER

PRODUCT SPECIFICATIONS

PRODUCT MODEL NO:	VK2P
FLUID RESISTANCE:	Horizontal FDF Twin Tank - 4 Levels
MONITOR:	FDF PLUS Colsole
PRODUCT NET WEIGHT:	32.70kg [72.08lb]
PRODUCT GROSS WEIGHT:	38.20kg [84.21lb]
DIMENSIONS:	L 2,130mm [83.85"] x W 540mm [21.25"] x H 520mm [20.47"]
MIN ACTIVE AREA REQUIRED:	L 2,450mm [96.45"] x W 1,150mm [45.27"]
STORED VERTICAL DIMENSIONS:	L 520mm [20.47"] x W 540mm [21.25"] x H 2,130mm [83.85"]
MAX USER WEIGHT:	150kg [330lb]
COMMERCIAL WARRANTY:	Frame 10 years - Fluid Tank 5 years Mechanical and all other non wearing components - 2 years

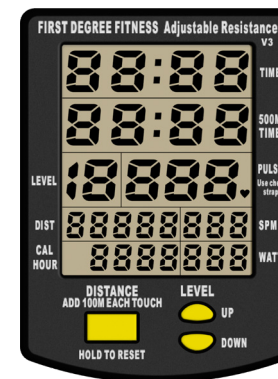

CONSOLE FEATURES

- + Auto start
- + Time - Elapsed time
- + 500M Time - Time to row 500 meters
- + Watt - Unit of power per stroke
- + Distance - Updated every meter
- + SPM - Strokes per minute
- + Calories burned per hour
- + Level - Up/Down to align level of selected fluid resistance
- + Pulse - Requires optional fitted receiver and chest strap (sold separately)

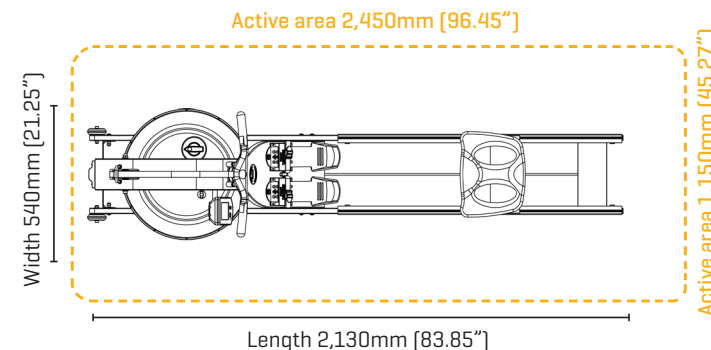

ABOUT FDF (FIRST DEGREE FITNESS)

FDF is the leader in designing and manufacturing a range of adjustable Fluid Resistance fitness machines for commercial and residential applications. At the heart of the fitness range is our unique and patented Twin Tank Fluid Resistance system. The adjustable Fluid Resistance system challenged the conventional thinking of how water could work to provide adjustable resistance rather than just a liquid mass flywheel. The patented Twin Tank system provides silky smooth resistance at any speed and is perfect for cardio training, warm-ups, cool downs, intense HIIT workouts or rehabilitation programs. FDF categorizes the range of adjustable Fluid Resistance machines under the banners, **FluidRower**, **FluidExercise** and **FluidPowerZone**, see the adjacent web links. FDF products are distributed throughout the globe and are popular in Fitness Centers, Hotels and Apartments, Sporting Clubs, Universities, First Responders, Defence Force Training Facilities and Physical Rehabilitation Clinics.

OPTIONAL FLUIDROWER ACCESSORIES



SEAT BACK KIT



ELEVATE KIT



View all products ranges at
FLUIDPOWERZONE.com

FLUIDROWER.com
FLUIDEXERCISE.com