



TAURUS 450

SERVICE MANUAL

NOTICE

This manual was produced by the NUBULA Group primarily for use by NUBULA dealers and their qualified mechanics. It is not possible to include all the knowledge of a mechanic in one manual, so it is assumed that anyone who uses this book to perform maintenance and repairs on NUBULA vehicle has a basic understanding of the mechanical ideas and the procedures of vehicle repair. Repairs attempted by anyone without this knowledge are likely to render the vehicle unsafe and unfit for use.

NUBULA Group is continually striving to improve all its models. Modifications and significant changes in specifications or procedures will be forwarded to all authorized dealers and will appear in future editions of this manual where applicable.

NOTE:

Designs and specifications are subject to change without notice.

IMPORTANT INFORMATION

Particularly important information is distinguished in this manual by the following notations.



The Safety Alert Symbol means ATTENTION! BECOME ALERT! YOUR SAFETY IS INVOLVED!

WARNING

Failure to follow WARNING instructions could result in severe injury or death to the vehicle operator, passenger, a bystander, or a person checking or repairing the vehicle.

CAUTION:

A CAUTION indicates special precautions that must be taken to avoid damage to the vehicle.

NOTE:
clearer.

A NOTE provides key information to make procedures easier or

CONTENTS

| | |
|----------------|----------------------------|
| CHAPTER1 | <i>General Information</i> |
| CHAPTER2 | <i>Maintenance</i> |
| CHAPTER3..... | <i>Dynamic system</i> |
| CHAPTER4..... | <i>Chassis</i> |
| CHAPTER5..... | <i>Final Drive</i> |
| CHAPTER6..... | <i>Brakes</i> |
| CHAPTER7..... | <i>Electrical</i> |

 **WARNING**

Never run an engine in an enclosed area. Carbon monoxide exhaust gas is poisonous and can cause severe injury or death. Always start engines outdoors.

Gasoline is extremely flammable and explosive under certain conditions. Battery electrolyte is poisonous. It contains sulfuric acid. Serious burns can result from contact with skin, eyes or clothing. Always keep alert and wear protection.

Exhaust system components are very hot during and after use of UTV. Never service when the engine is warm or hot. Escaping steam from cooling system or hot oil from the machine can cause severe burns. The engine must be cool before service.

Crate of the UTV and parts in the UTV maybe have sharp edge, always pay attention and wear protection.

CHAPTER 1 GENERAL INFORMATION

 WARNING

The parts of different types/ variants/ versions maybe un-interchangeable, even some parts have almost same appearance. Always refer to Parts Manual of each UTV model for spare parts information and service.

1.1 IMPORTANT INFORMATION

1.2 V.I.N AND MOTOR SERIAL NUMBER

1.3 VEHICLE DIMENSIONS

1.1 IMPORTANT INFORMATION

PREPARATION FOR REMOVAL PROCEDURES

1. Remove all dirt, mud, dust and foreign material before removal and disassembly.
2. Use proper tools and cleaning equipment.
3. When disassembling the machine, always keep mated parts together. This includes gears, cylinders, pistons and other parts that have been “ mated ”through normal wear. Mated part must always be reused or replaced as an assembly.
4. During machine disassembly, clean all parts and place them in trays in the order of disassembly. This will speed up assembly and allow for the correct installation of all parts.
5. Keep all parts away from any source of fire.

REPLACEMENT PARTS

Use only genuine parts for all replacements. Use recommended oil and grease for all lubrication jobs. Other brands may be similar in function and appearance, but inferior in quality.

GASKETS,OIL SEALS AND O-RINGS

1. Replace all gaskets seals and O-rings when overhauling the engine. All gasket surfaces, oil seal lips and O-rings must be cleaned.
2. Properly oil all mating parts and bearings during reassembly. Apply grease to the oil seal lips.

LOCK WASHERS/PLATES AND COTTER PINS

Replace all lock washers/plates and cotter pins after removal. Bend lock tabs along the bolt or nut flats after the bolt or nut has been tightened to specification.

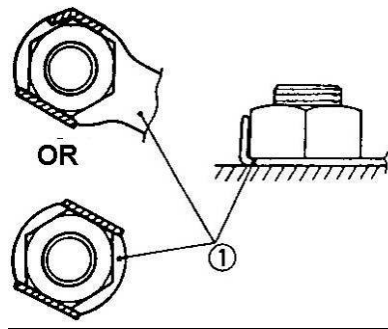

BEARINGS AND OIL SEALS

Install bearings and oil seals so that the manufacturer’s marks or numbers are visible. When installing oil seals, apply a light coating of lightweight lithium base grease to the seal lips. Oil bearings liberally when installing, if appropriate.

① oil seal

CAUTION:

Do not use compressed air to spin the bearings dry. This will damage the bearing surfaces.

① Bearing

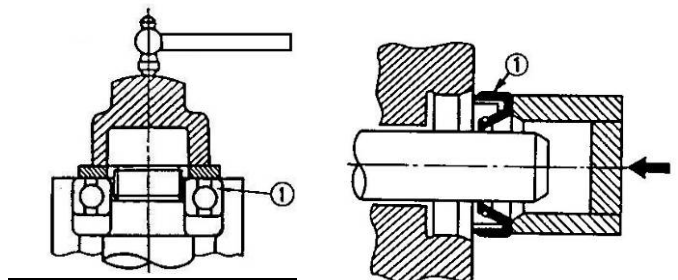

CIRCLIPS

1. Check all circlips carefully before reassembly. Always replace piston pin clips after one use.

Replace distorted circlips. When installing a circlip ①, make sure that the sharp-edged corner ② is positioned opposite the thrust ③ it receives. See sectional view.

④ Shaft

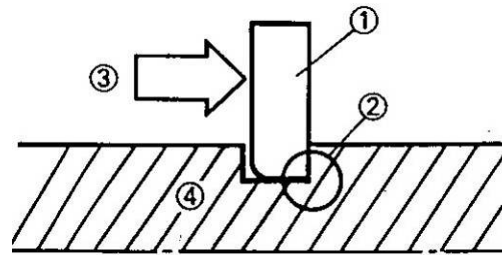

CHECKING OF CONNECTIONS

Dealing with stains, rust, moisture, etc. on the connector.

1. Disconnect:
 - Connector
2. Dry each terminal with an air blower.
3. Connect and disconnect the connector two or three.
4. Pull the lead to check that it will not come off.
5. If the terminal comes off, bend up the pin ① and reinsert the terminal into the connector.
6. Connect:
 - Connector

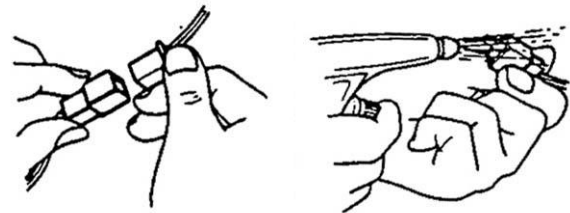

NOTE:

The two connectors "click" together.

7. Check for continuity with a tester.

NOTE:

- If there is no continuity, clean the terminals.
- Be sure to perform the steps 1 to 7 listed above when checking the wire harness.
- Use the tester on the connector as shown.

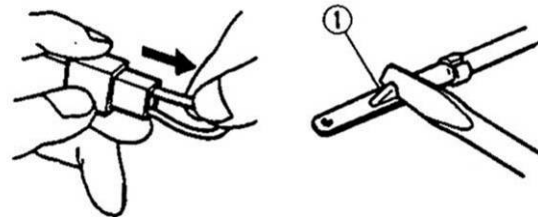

⚠ WARNING

Never run an engine in an enclosed area. Carbon monoxide exhaust gas is poisonous and can cause severe injury or death. Always start engines outdoors.

Gasoline is extremely flammable and explosive under certain conditions. Battery electrolyte is poisonous. It contains sulfuric acid. Serious burns can result from contact with skin, eyes or clothing. Always keep alert and wear protection.

Exhaust system components are very hot during and after use of UTV. Never service when the engine is warm or hot. Escaping steam from cooling system or hot oil from the machine can cause severe burns. The engine must be cool before service.

Crate of the UTV and parts in the UTV maybe have sharp edge, always pay attention and wear protection.

CONVERSION TABLE

How to use the CONVERSION TABLE

Use this table to convert METRIC unit data to IMPERIAL unit data.

Ex.

| | | | | |
|--------|---|------------|---|------|
| METRIC | | MULTIPLIER | | IMP |
| **mm | x | 0.3937 | = | **in |
| **cm | x | 0.03937 | = | **in |

CONVERSION TABLE

| METRIC TO IMP | | | |
|---------------------|----------------------|------------|--------------------------|
| | Known | Multiplier | Result |
| Torque | m • kg | 7.233 | ft • lb |
| | m • kg | 86.794 | ln • lb |
| | cm • kg | 0.0723 | ft • lb |
| | cm • kg | 0.8679 | ln • lb |
| Weight | kg | 2.205 | lb |
| | g | 0.03527 | oz |
| Distance | km/h | 0.6214 | mph |
| | km | 0.6214 | mi |
| | m | 3.281 | ft |
| | m | 1.094 | yd |
| | cm | 0.3927 | in |
| Volume/ Capacity | mm | 0.03927 | in |
| | cc(cm ³) | 0.03527 | oz(IMP liq.) |
| | cc(cm ³) | 0.06102 | cu • in |
| | lit(liter) | 0.8799 | qt (IMP liq.) |
| Miscellaneous | lit(liter) | 0.2199 | gal(IMP liq.) |
| | kg/mm | 55.997 | lb/in |
| | kg/cm ² | 14.2234 | psi(lb/in ²) |
| | Centigrade | 9/5(°C)+32 | Fahrenheit(° F) |

1.2 V.I.N AND ENGINE SERIAL NUMBER

The vehicle identification number ① is stamped into the left side of the rear frame tube.

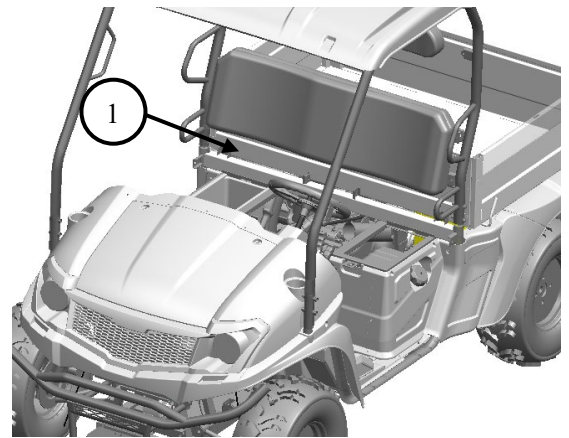

The engine serial number ② is stamped into left side of engine crankcase.

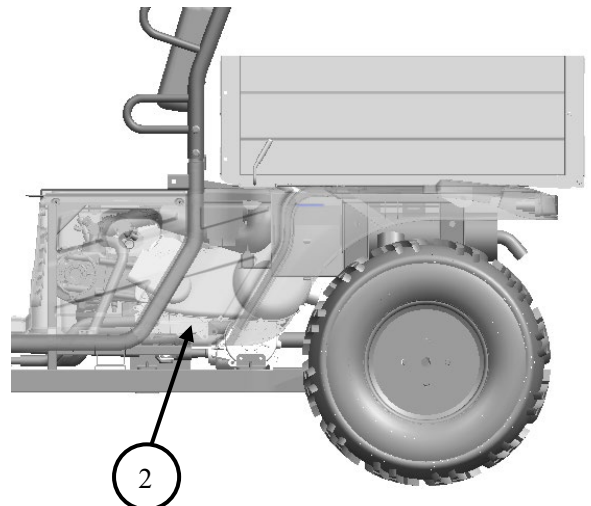

The transmission serial number ③ is stamped into back side of transmission case.

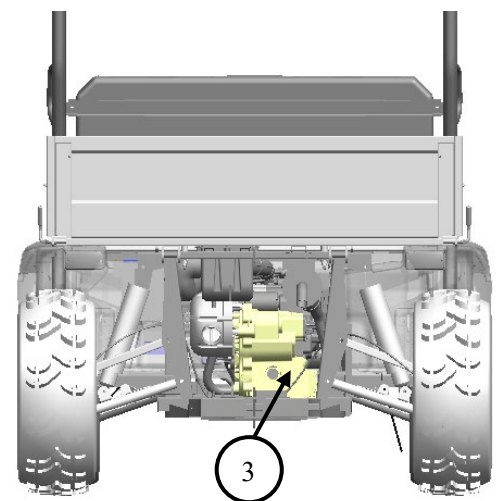

1.3 VEHICLE DIMENSIONS

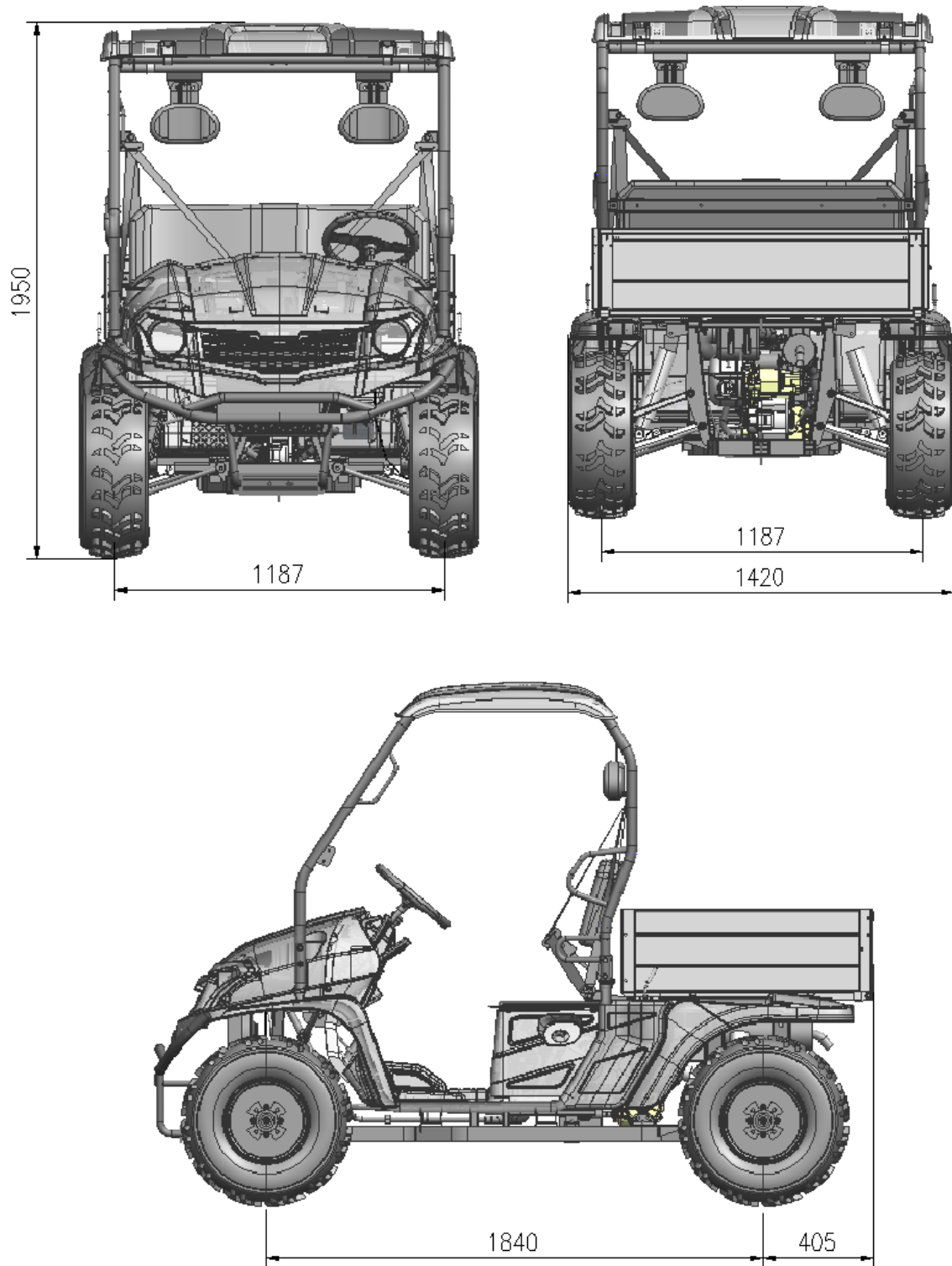

Note.

The on-road equipments (rear view mirror, turn lights, etc.) are not Standard Equipment for USA.

CHAPTER 2 MAINTENANCE

WARNING

The parts of different types/ variants/ versions maybe un-interchangeable, even some parts have almost same appearance. Always refer to Parts Manual of each UTV model for spare parts information and service.

2.1 PERIODIC MAINTENANCE

2.2 THROTTLE PEDAL INSPECTION

2.3 FUEL SYSTEM

2.4 TOE ALIGNMENT

2.5 BRAKING SYSTEM INSPECTION

2.6 SUSPENSION SPRING RPELOAD ADJUSTMENT

2.7 WHEELS

2.8 TIRE PRESSURE

2.9 FRAME, NUTS, BOLTS, FASTENERS

2.1 PERIODIC MAINTENANCE



CAUTION

Due to the nature of the adjustments marked with a **D** on the following chart, it is recommended that service be performed by an authorized dealer.

- More often under severe use, such as dirty or wet conditions to purge water or dirt contamination from grease fittings and other critical components.

PERIODIC MAINTENANCE SCHEDULE:

Careful periodic maintenance will help keep your vehicle in the safest, most reliable condition. Inspection, adjustment and lubrication intervals of important components are explained in the following chart on the following pages.

Maintenance intervals are based upon average riding conditions and an average vehicle speed of approximately 16km/h (10 miles per hour). Vehicles subjected to severe use, such as operation in wet or dusty areas, should be inspected and serviced more frequently.

Inspect, clean, lubricate, adjust or replace parts as necessary.

NOTE:

Inspection may reveal the need for replacement parts. Always use genuine parts available from your dealer.

Service and adjustments are critical. If you are not familiar with safe service and adjustment procedures, ask for a qualified dealer perform these operations.

| | Item | Hours | When | Remarks |
|----------|--------------------------------|--------------|-------------|--|
| ● | Brake System | Pre-ride | Pre-ride | Pre-ride inspection item |
| | Accelerator pedal | Pre-ride | Pre-ride | Inspect –adjust, lubricate, replace if necessary; pre-ride inspection item |
| | Fuel System | Pre-ride | Pre-ride | Check for leaks at tank cap, lines, fuel valve, filter, and carburetor |
| ● | Tires | Pre-ride | Pre-ride | Inspect daily, pre-ride inspection item |
| ● | Front and Rear Wheels/ Hubs | Pre-ride | Pre-ride | Pre-ride inspection item |
| ● | Steering | Pre-ride | Pre-ride | Inspect daily, lubricate |
| D | Wheels Bearings | 10 hrs | Monthly | Check for looseness/ damage. Replace if damaged |
| | Frame Nuts, Bolts Fasteners | Pre-ride | Pre-ride | Pre-ride inspection item |
| ● | Air Filter-Pre-Cleaner | Daily | Daily | Inspect-Clean |
| | Coolant/Level Inspection | Daily | Daily | Replace engine coolant every one year |

| | | | | |
|---|--|-------------|-------------|---|
| ● | Air Box Sediment Tube | Daily | Daily | Drain deposits whenever visible |
| | Headlamp Inspection | Daily | Daily | Check operation daily; apply dielectric grease to connector when replaced |
| | Tail / Indicator Lamp Inspection | Daily | Daily | Check operation daily; apply dielectric grease to socket when replaced |
| ● | Air Filter-Main Element | Weekly | Weekly | Inspect –Replace if necessary |
| ● | Transmission Oil Level | 20 hrs | Monthly | Inspect monthly; change annually |
| | Battery | 20 hrs | Monthly | Check/clean Terminals; check fluid level |
| D | Brake Pad Wear | 10 hrs | Monthly | Inspect periodically |
| ● | Front/Rear axle Gear case Oil | 100 hrs | Monthly | Check yearly or every 100 hours |
| | Engine Cylinder Head and Cylinder Base Fasteners | 25 hrs | 3 months | Inspect (re-torque required at first service only) |
| ● | General Lubrication | 50 hrs | 3 months | Lubricate all fittings, pivots, cables, etc. |
| ● | Engine Oil-Level/Change | 30 hrs | 3 months | Check Level Daily; Break in Service at 1 month. Change oil more often in cold weather use |
| ● | Dipstick | 50 hrs | 6 months | Inspect - clean |
| | Engine Breather Hose | 100 hrs | 6 months | Inspect |
| D | Throttle Cable / Accelerator Pedal | 20 hrs | monthly | Inspect – adjust, lubricate, replace if necessary; pre-ride inspection item |
| | Shift Linkage | 50 hrs | 6 months | Inspect, adjust |
| D | Drive Belt | 50 hrs | 6 months | Inspect, replace if necessary |
| D | Steering System | 50 hrs | 6 months | Check operation and for looseness, worn, damage, binding feeling / Adjust, repair, Replace if necessary. Check toe alignment /Adjust if necessary. |
| D | Toe Alignment Adjustment | As required | As required | Periodic inspection, adjust when parts are replaced |
| D | Shaft | 50 hrs | 6 months | Check for looseness/ damage |
| ● | Axle | 50 hrs | 6 months | Inspect bearings, Lube |
| ● | Front Prop Shaft & Shaft Yoke | 50 hrs | 6 months | Check for looseness/ damage |
| ● | Rear Prop Shaft, Shaft Yoke & Boots | 50 hrs | 6 months | Check for/ boots/ looseness/ damage |
| ● | Front Suspension | 50 hrs | 6 months | Inspect - lubricate, tighten fasteners |
| ● | Rear Suspension | 50 hrs | 6 months | Inspect, tighten fasteners |
| | Spark Plug | 100 hrs | 12 months | Inspect - replace if necessary |
| D | Ignition Timing | 100 hrs | 12 months | Inspect and adjust as needed |

| | | | | |
|----------|-----------------------------|-------------|-------------|---|
| D | Fuel System | 50 hrs | 6 months | Check for leaks at tank cap, lines, fuel filter. Replace lines every one year |
| D | Fuel Filter | 100 hrs | 12 months | Replace annually |
| | Radiator | 100 hrs | 12 months | Inspect/clean external surface |
| | Spark Arrestor | 50 hrs | 3 months | Clean out-replace if necessary |
| D | Clutches (drive and driven) | 25 hrs | 3 months | Inspect, clean |
| | Engine Mounts | 25 hrs | 3 months | Inspect |
| D | Valve Clearance | 100 hrs | 12 months | Inspect/adjust |
| D | Brake Fluid | 200 hrs | 24 months | Change every two years |
| | Idle Speed | As required | As required | Adjust |
| | Headlight Aim | As required | As required | Adjust if necessary |

LUBRICANT AND FLUID

| | Item | Lube Rec | Method | Frequency |
|---|--|-----------------|---|---|
| ● | 1. Engine Oil | SAE 15W/40SG | Add to proper level on dipstick | Check level daily |
| | 2. Brake Fluid | DOT 3 Only | Maintain level between fill lines | As require; change every two years or 200 hours |
| | 3. Transmission Oil | SAE 80W/90GL5 | Add to proper level on dipstick | Change annually or 100 hours |
| | 4. Front / Rear Axle Gear Case Oil | SAE 80W/90GL5 | Fill the bottom of the fill plug threads | Change annually or 100 hours |
| ● | 5. Steering System | Grease | Lubricate the pivoting and sliding parts | Every 3 months or 50 hours |
| ● | 6. Shift Linkages | Grease | Locate fittings and Grease | Semi-annually |
| ● | 7. Tie Rods | Grease | Grease | Semi-annually |
| ● | 8. Ball Joints | Grease | Inspect, Locate fittings and Grease, or replace it if necessary | Semi-annually |
| ● | 9. Prop Shaft & Shaft Yoke, Spline Joint | Grease | Locate fitting and Grease | Semi-annually |
| ● | 10. Cooling Liquid | HEC-II -35 | Maintain level between fill lines | Check level daily |
| ● | 11. Front / Rear A-arm Pivot Shaft | Grease | Locate fitting on pivot shaft and grease with grease gun | Every 3 months or 50 hours |
| ● | 12. Throttle Cable | Grease M | Grease, inspect and replace it if necessary | Monthly or 20 hours |
| ● | 13. Accelerator Pedal and brake pedal | Grease | Grease, inspect | Monthly or 20 hours |

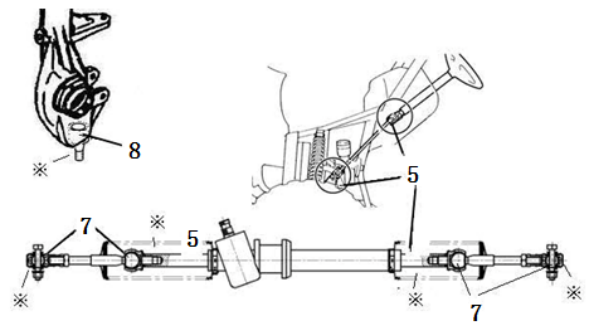
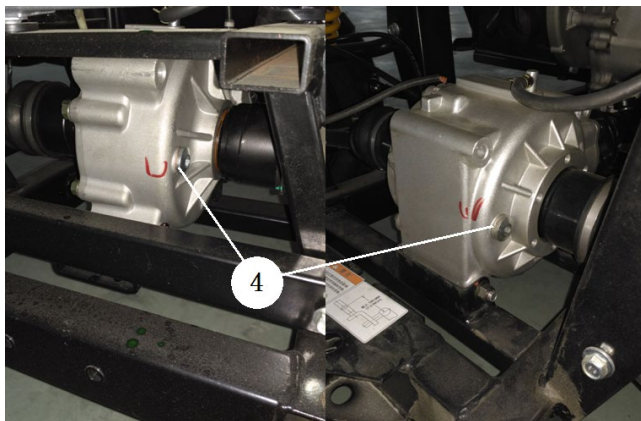
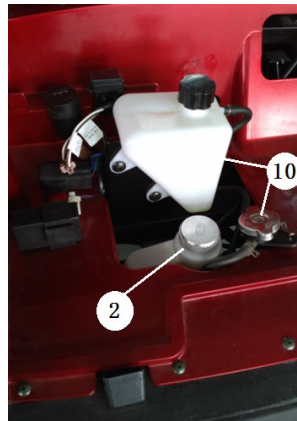
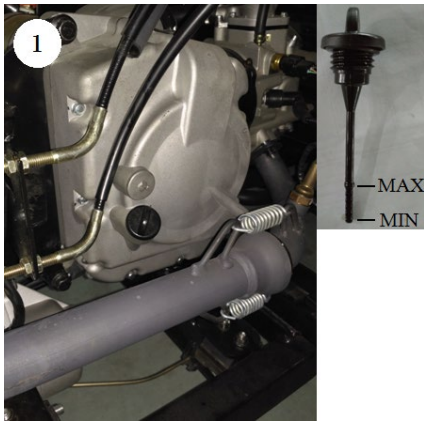

※---Check the protective boots for holes or tears. If any damage is found, have them replaced by an authorized dealer.

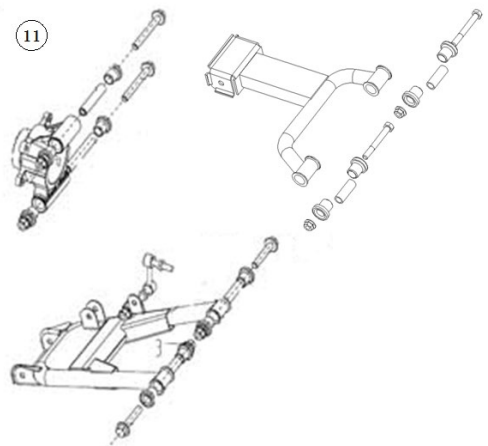
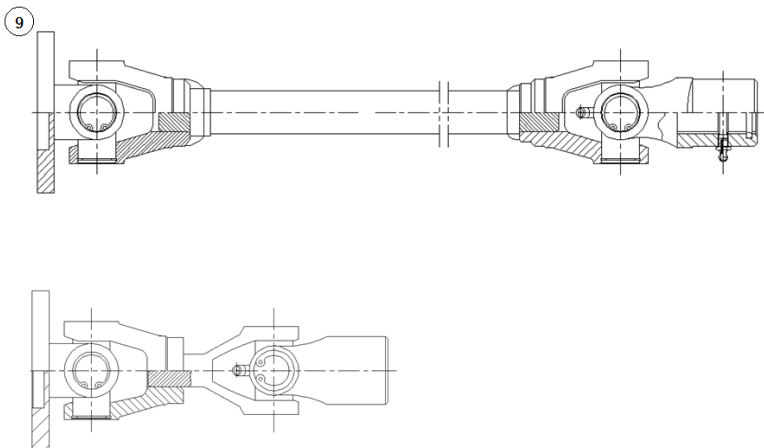

LUBRICATION RECOMMENDATIONS

NOTE:

1. More often under severe use, such as wet or dusty conditions.
2. Grease: Light weight lithium-soap grease.
3. Grease M: Molybdenum disulfide (MoS₂) grease (water resistant).
4. When suspension action becomes stiff or after washing.
5. Hours are based on 10 mph(16Km/h) average.

2.2 THROTTLE PEDAL INSPECTION

THROTTLE FREEPLAY

If the throttle pedal has excessive play due to cable stretch or cable misadjustment, it will cause a delay in throttle speed. Also, the throttle may not open fully. If the throttle pedal has no play, the throttle may be hard to control, and the idle speed may be erratic. Check the throttle pedal play periodically in accordance with the Periodic Maintenance Chart and adjust the play if necessary.

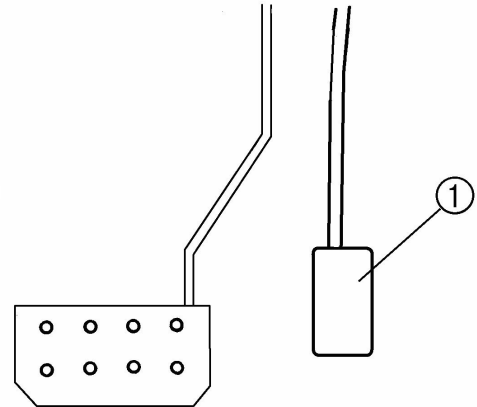

THROTTLE FREEPLAY INSPECTION

1. Apply the parking brake.
2. Put the gear shift lever in the N(Neutral) position.
3. Start the engine, and warm it up thoroughly.
4. Measure the distance the throttle pedal moves before the engine begins to pick up speed. Free play should be 1.5 – 3 mm.

Adjustment

1. Slide the boot off inline cable adjuster sleeve. Loosen adjuster locknut.
2. Turn adjuster until 1.5 to 3 mm, free play is achieved pedal. NOTE: While adjusting free play, it is important you flip the throttle lever back and forth.
3. Tighten locknut.

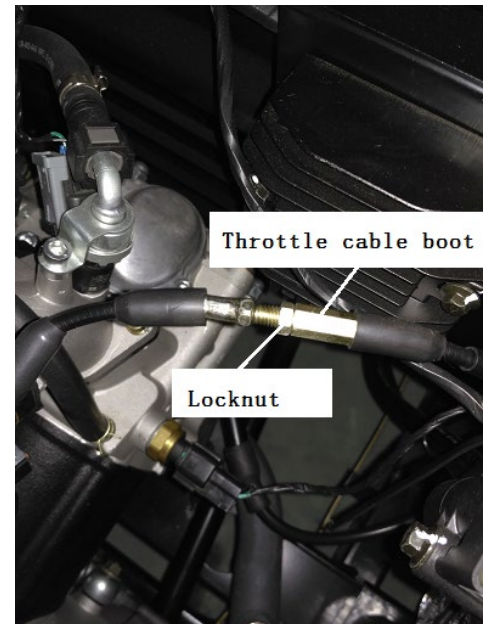

2.3 FUEL SYSTEM

! WARNING

Gasoline is extremely flammable and explosive under certain conditions.

- !** Always stop the engine and refuel outdoors or in a well ventilated area.
- !** Do not smoke or allow open flames or sparks in or near the area where refueling is performed or where gasoline is stored.
- !** Do not overfill the tank. Do not fill the tank neck.
- !** If you get gasoline in your eyes or if you swallow gasoline, see your doctor immediately.
- !** If you spill gasoline on your skin or clothing, immediately wash it off with soap and water and change clothing.
- !** Never start the engine or let it run in an enclosed area. Gasoline powered engine

exhaust fumes are poisonous and can cause loss of consciousness and death in a short time.

 Never drain the float bowl when the engine is hot. Severe burns may result.

FUEL LINES

1. Check fuel lines for signs of wear, deterioration, damage or leakage. Replace if necessary.
2. Be sure fuel lines are routed properly and secured with cable ties.

CAUTION:

Make sure lines are not kinked or pinched.
 Replace all fuel lines every two years.

FUEL FILTER

The fuel filter should be replaced in accordance with the Periodic Maintenance Chart or whenever sediment is visible in the filter.

1. Remove line connectors at both ends of fuel filter.
2. Install new fuel filter onto fuel lines (the direction of fuel flow should be IN → OUT).
3. Start engine and inspect for leaks.

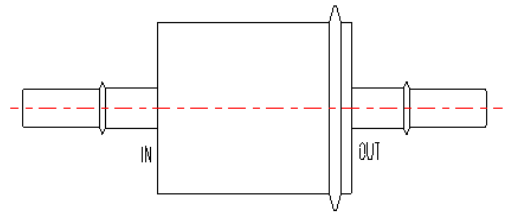
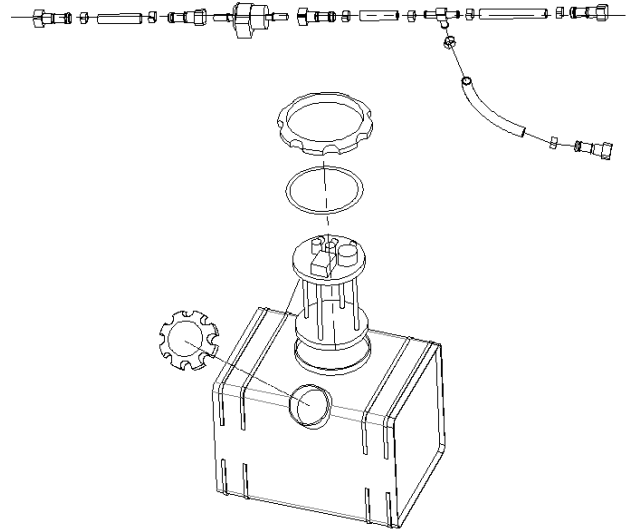

2.4 TOE ALIGNMENT

METHOD: STRAIGHTEDGE OR STRING

Be sure the steering wheel in a straight ahead position.

NOTE: String should just touch side surface of rear tire on each side of the UTV.

The recommended toe alignment is 0 to 13/64”(0 to 5mm) toe in.

1. Set the steering wheel in a straight ahead position and hold them in this position.
2. Measure A and B, A minus B should be 0 to 6/64” (0 to 2.5mm).

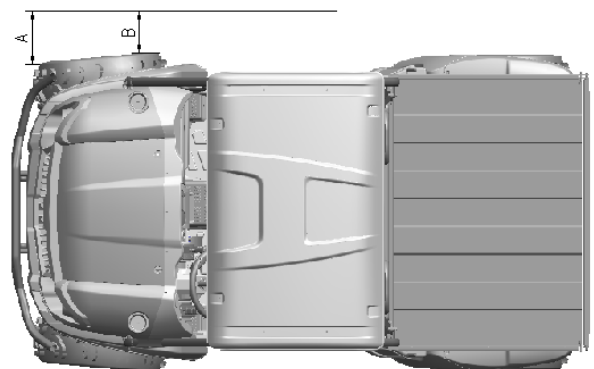

⚠ WARNING

Always pay attention to tie rods assembly, Both ends must screw in same and enough threads length.

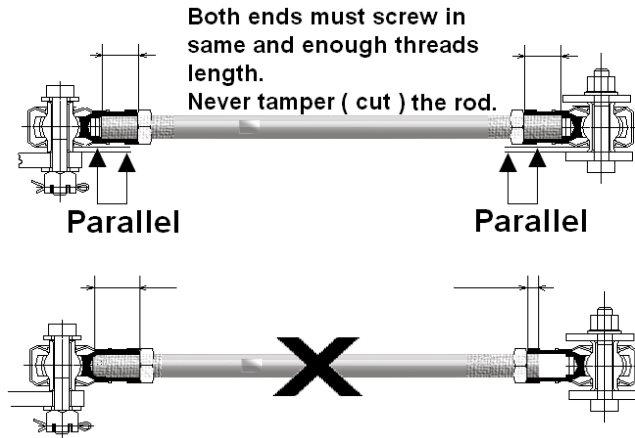

2.5 BRAKING SYSTEM INSPECTION

The following checks are recommended to keep the braking system in good operating condition. Service life of braking system components depends on operating conditions. Inspect brakes in accordance with the maintenance schedule and before each ride

- Keep fluid level in the master cylinder reservoir to the indicated level on reservoir.
- Use DOT 3 brake fluid.

NOTE: Use new brake fluid or brake fluid from a sealed container to avoid contamination to system.

- Check brake system for fluid leaks.
- Check brake for excessive travel or spongy feel.
- Check friction pads for wear, damage and looseness.
- Check surface condition of the disc.

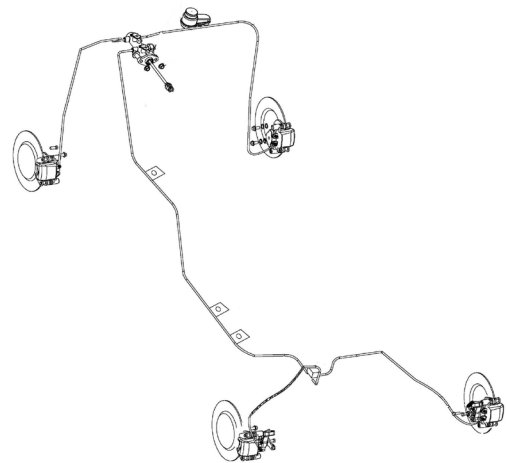

BRAKE PAD INSPECTION

Pads should be changed when friction material is worn to 3/64" (1mm).

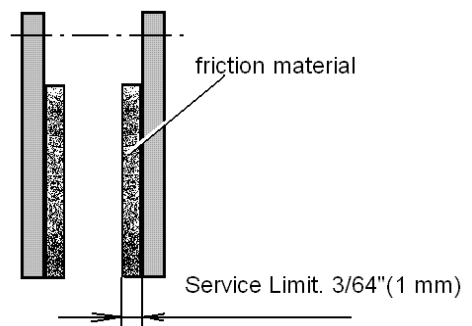

HOSE/FITTING INSPECTION

Check braking system hoses and fittings for cracks, deterioration, abrasion, and leaks. Tighten any loose fittings and replace any worn or damaged parts.

ADJUSTING THE BRAKE PEDAL

Check the brake pedal free play. Free play should be 8 – 12mm. Out of specification →Adjust.

1. Loosen the locknut
2. Turn brake rod in or out until the correct free play is obtained.
Turning in: Free play is increased.
Turning out: Free play is decreased.
3. Tighten the locknut

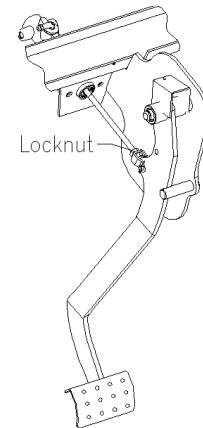
**ADJUSTING THE PARKING BRAKE**

Although the parking brake has been adjusted at the factory, the brake should be checked for proper operation. The mechanical brake must be maintained to be full functional.

1. With the engine off, apply the parking brake lever and attempt to move the UTV.
2. If the rear wheels are locked, it is adjusted properly.
3. If the wheels are not locked, it must be adjusted.

To adjust (set up) the mechanical parking brake, use the following procedure

Note: The adjusting on the caliper is for the wear out of the pads.

1. With the engine off, loosen the adjustor on the lever.
2. Loosen the jam nut of the adjuster on the caliper.
3. Turn the adjuster (bolt) CW (clockwise) by hand till the pad touch the brake disc, turn the adjuster bolt CCW (counterclockwise) by 1/4 to one turn for 10 to 20mm free play at the end of the parking lever.
4. Tighten the jam nuts securely against the adjusters.
5. Make sure the rear wheels turns freely without dragging.
6. Turn the adjustor (the one on the lever) and apply the lever. While adjusting, it is important you apply the lever back and forth for operation, free play and the locking of the parking position.
7. Make sure the rear wheels turns freely without dragging and parking brake works properly.
8. Field test for parking. It must be capable of holding the laden UTV stationary on an 18% up and down gradient.

A temporary adjusting can also be done to the brake cable on the parking lever side by turn the adjuster (nut) directly. But the adjust range is limited. Always do the **procedure 1 to 8** when necessary.

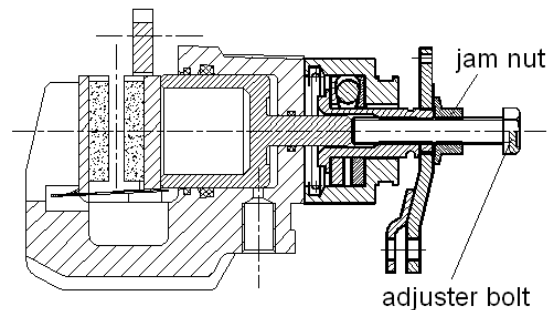

2.6 SUSPENSION SPRING RPELOAD ADJUSTMENT

Operator weight and vehicle loading affect suspension spring preload requirements. Adjust as necessary.

FRONT SUSPENSION

Compress and release front suspension. Damping should be smooth throughout the range of travel.

Check all front suspension components for wear or damage.

Inspect from strut cartridges for leakage. Shock spring preload can not be adjusted, replace if necessary.

REAR SUSPENSION

Compress and release rear suspension. Damping should be smooth throughout the range of travel. Check all rear suspension components for wear or damage.

Inspect shock for leakage

Shock spring preload can be adjusted using the shock spanner wrench.

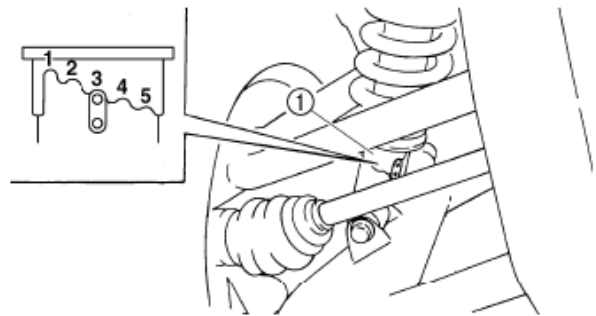

⚠ WARNING

Always adjust both shock absorber spring preload to the same setting. Uneven adjustment can cause poor handling and loss of stability.

Turn the adjuster ① to increase or decrease the spring preload.

Standard position: 3

Minimum (Soft) position: 1

Maximum (Hard) position: 5

2.7 WHEELS

Inspect all wheels for runout of damage.

Check wheel nuts and ensure they are tight.

Do not over tighten the wheel nuts.

WHEEL REMOVAL

1. Stop the engine, place the transmission in gear and lock the parking brake.
2. Loosen the wheel nuts slightly.
3. Elevate the side of the vehicle by placing a suitable stand under the footrest frame.
4. Remove the wheel nuts and remove the wheel.

WHEEL INSTALLATION

1. With the transmission in gear and the parking

brake locked, place the wheel in the correct position on the wheel hub. Be sure the valve stem is toward the outside and rotation arrows on the tire point toward rotation.

2. Install the wheel nuts and tighten them by hand.
3. Lower the vehicle to the ground.
4. Securely tighten the wheel nuts to the proper torque listed in the table. On wheel nuts, Make sure tapered end of nut goes into taper on wheel.

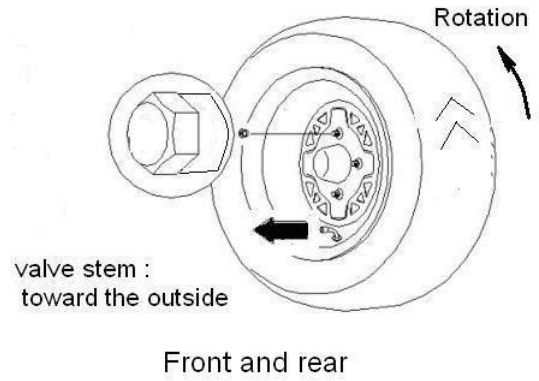

Wheel Nut Torque Specifications

| Bolt Size | | Specification | |
|-----------|----------|---------------|------|
| Front | M12X1.25 | 59Ft.Lbs | 66Nm |
| Rear | M12X1.25 | 59Ft.Lbs | 66Nm |

CAUTION:

If wheels are improperly installed it could affect Vehicle handling and tire wear.

2.8 TIRE PRESSURE

TIRE INSPECTION

CAUTION:

- Maintain proper tire pressure. Refer to the warning tire pressure decal applied to the vehicle.
- Improper tire inflation may affect UTV maneuverability.
- When replacing a tire always use original equipment size and type and replace in pairs.
- The use of non- standard size or type tires may affect UTV handling and cause machine damage.

| Tire Pressure | |
|---------------|------------|
| front | rear |
| 48kPa/7SI | 48kPa/7PSI |

TIRE TREAD DEPTH

Always replace tires when tread depth is worn to 1/8" (3mm) or less.

⚠ WARNING

Operating an UTV with worn tires will increase the possibility of the vehicle skidding easily with possible loss of control.

Worn tires can cause an accident. Always replace tires when the tread depth measures 1/8" (3mm) or less.

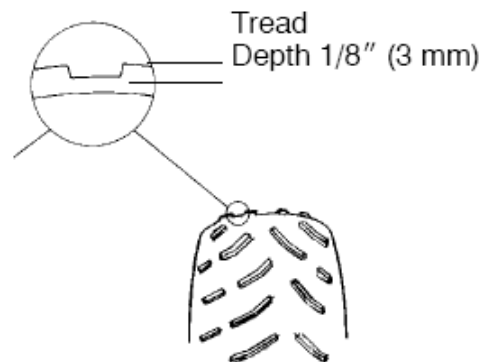

2.9 FRAME , NUTS, BOLTS, FASTENERS

Periodically inspect the tightness of all fasteners in accordance with the maintenance schedule. Check that all cotter pins are in place. Refer to specific fastener torques listed in each chapter.

CHAPTER 3 ENGINE

3.1 MAINTENANCE SPECIFICATIONS

- 3.1.1 SPECIFICATIONS
- 3.1.2 TIGHTENING TORQUES

3.2 PARTS INSPECTION AND SERVICE

- 3.2.1 VALVE CLEARANCE ADJUSTMENT
- 3.2.2 IDLING SPEED ADJUSTMENT
- 3.2.3 SPARK PLUG INSPECTION
- 3.2.4 COMPRESSION PRESSURE
- 3.2.5 ENGINE OIL LEVEL INSPECTION
- 3.2.6 COOLANT LEVEL INSPECTION

3.3 CYLINDER HEAD

3.4 CAMSHAFT AND ROCKER ARMS

3.5 VALVES AND VALVE SPRINGS

3.6 CYLINDER AND PISTON

3.7 V-BELT, CLUTCH AND SECONDARY/PRIMARY SHEAVE

3.8 A.C. MAGNETO AND STARTER CLUTCH

3.9 OIL PUMP

3.10 CRANKCASE AND CRANKSHAFT

3.11 COOLING SYSTEM

- 3.11.1 RADIATOR
- 3.11.2 WATER PUMP
- 3.11.3 THERMOSTAT

3.1 MAINTENANCE SPECIFICATIONS

3.1.1 SPECIFICATIONS

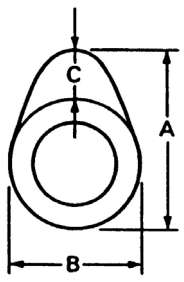
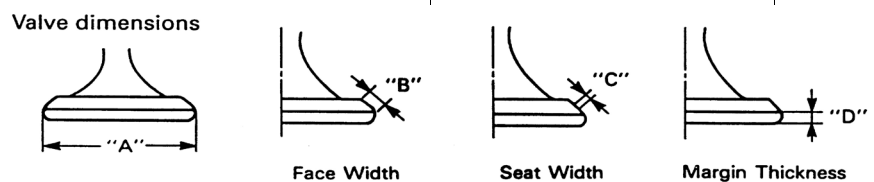
| Item | Standard | Limit |
|--|--|--|
| Cylinder head : Warp limit | | 0.03 mm |
| Cylinder: Bore size Out of round limit | 82.000- 82.014 mm | 82.025 mm 0.03 mm |
| Camshaft: Cam dimensions Intake "A" "B" "C" Exhaust "A" "B" "C" Camshaft runout limit |  36 .545-36 .645 mm 30.021-30.121 mm 6.524 mm 36 .547- 36 .647 mm 30 .067- 30.167 mm 6.48 mm | 36 .45 mm 29.92 mm ... 36 .45 mm 29 .97 mm ... 0.03m m |
| Cam chain: Cam chain type/No. of links | DID SC.A-0404A SDH/108 | ... |
| Rocker arm /rocker arm shaft: Rocker arm inside diameter Rocker shaft outside diameter Rocker arm - to- rocker arm shaft Clearance | 12.000- 12.018 mm 11.981- 11.991 mm 0.009- 0.012 mm | 12 .03 mm 11.95 mm ... |
| Valve, Valve seat, Valve guide: Valve clearance (cold) Valve dimensions | IN 0.12-0.14 mm EX 0.14-0.16 mm  | |
| "A" head diameter | IN 37.4-37.6mm EX 33.5-33.6mm | |
| "B" face width | IN 3.394-3.960mm EX 3.394-3.960 mm | |
| "C " seat width | IN 0.9-1.1mm EX 0.9-1.1 mm | |
| "D" margin thickness | IN 0.8-1.2 mm EX 0.8-1.2 mm | |
| Stem outside diameter | IN 5.973- 5.995 mm EX 5.960-5.977 mm | 5.94 mm 5.92 mm |
| Guide inside diameter | IN 6.000- 6.012 mm EX 6.000- 6.012 mm | 6.05 mm 6.05 mm |

| Item | Standard | Limit |
|------|----------|-------|
|------|----------|-------|

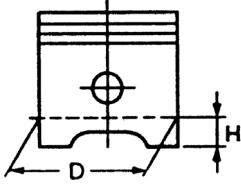
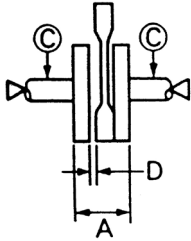
| | | | |
|-----------------------------------|---|-----------------------------------|-------------------|
| Stem-to-guide clearance | IN EX | 0.010- 0.037 mm 0.025-0.052 mm | 0.08 mm 0.1 mm |
| Stem runout limit | | ... | 0.01 mm |
| Valve seat width | IN EX | 0.9-1.1 mm 0.9-1.1 mm | 1.6 mm 1.6 mm |
| Valve spring : | | | |
| Free length (Inner) | IN/EX | 38mm | 36.1 mm |
| (Outer) | IN/EX | 37.5mm | 35.0 mm |
| Set length (valve closed) (Inner) | IN/EX | 30 mm | ... |
| (Outer) | IN/EX | 31.6 mm | ... |
| Com pressed pressure (Inner) | IN/EX | 7.8- 9.0 kg | ... |
| (Outer) | IN/EX | 37.22-42.83 kg | ... |
| Tilt limit (Inner) | IN/EX | ... | 2.5° /1.7mm |
| (Outer) | IN/EX | ... | 2.5° /1.7mm |
| Piston: | | | |
| Piston to cylinder Clearance |  | 0.02 - 0.049mm | 0.15m m |
| Piston size "D" | | 81.965-81.980 mm | ... |
| Measuring point "H" | | 5mm | ... |
| Piston pin bore inside diameter | | 18.004-18.015 mm | 18.045 mm |
| Piston pin outside diameter | | 17 .994-18 .005 mm | 17 .975 mm |
| Piston rings : | | | |
| Top ring : | | | |
| Type | | Barrel | ... |
| End gap (installed) | | 0.2-0.35 mm | 0.5 mm |
| Side clearance (installed) | | 0.03-0.065 mm | 0.1 mm |
| 2nd ring : | | | |
| Type | | Taper | ... |
| End gap (installed) | | 0.28-0.48 mm | 0.73 mm |
| Side clearance | | 0.02-0.052 mm | 0.1 mm |
| Oil ring : | | | |
| End gap (installed) | | 0. 15-0.45 mm | ... |
| Crankshaft: | | | |
| |  | | |
| Crank width "A" | | 59.90-60.00 mm | ... |
| Runout limit "C " | | 0.03 mm | ... |
| Big end side clearance "D" | | 0.35- 0.85 mm | ... |

| Item | Standard | Limit |
|------|----------|-------|
|------|----------|-------|

| | | |
|--|---|--|
| Automatic centrifugal clutch: Clutch shoe thickness Clutch hosing inside diameter Clutch shoe spring free length Weight outside diameter Clutch operating speed | 3.0 mm 160 mm 28.1 mm 20 mm 2 ,900- 3,000 r/m in | 2.0 mm 160.5 mm ... 19 .5 mm ... |
| V-belt: V-belt width | 22.6 mm | 21.0 mm |
| Throttle: Type | No Adjustment | |
| Oil pump: Type Tip clearance Side clearance Housing and rotor clearance | Trochoid 0.1- 0.34 mm 0.013- 0.036 mm 0 .04- 0.09 mm | 0 .4 mm 0.15 mm 0.15 mm |
| Radiator: Type Width/height/thickness Radiator cap opening pressure Radiator capacity Reservoir tank capacity | Cooling fin with electric fan 360/246/68 mm 110-140kPa 2 L 0.35 L | |
| Thermostatic valve: Valve opening temperature Valve full open temperature Valve full open lift | 64-67°C 83 °C 7mm | |

3.1.2 TIGHTENING TORQUES

| Part to be tightened | Part name | Thread size | Q'ty | Tightening Torque | | Remarks |
|---------------------------------------|-----------|-------------|------|-------------------|------|---------|
| | | | | N.m | m.kg | |
| Magneto motor stator | Bolt | M6 | 3 | 10 | 1 | |
| Trigger | Bolt | M5 | 2 | 6 | 0.6 | |
| Oil pump | Bolt | M6 | 2 | 10 | 1 | |
| Drain cock | — | — | 1 | 30 | 3 | |
| Magneto motor rotor | Bolt | M8 | 6 | 26 | 2.6 | |
| Compression plate | Bolt | M6 | 2 | 10 | 1 | |
| Peep hole | Bolt | M6 | 1 | 10 | 1 | |
| Spark plug | — | — | 1 | 26 | 2.6 | |
| Water temperature sensor | — | — | 1 | 18 | 1.8 | |
| Thermostat | — | — | 1 | 15 | 1.5 | |
| Inlet pipe | Bolt | M6 | 2 | 10 | 1 | |
| Left box | Bolt | M6 | 8 | 10 | 1 | |
| Pull rod | — | — | 1 | 6 | 0.6 | |
| Water pump gears | Bolt | M6 | 2 | 6 | 0.6 | |
| Starting motor | Bolt | M6 | 2 | 10 | 1 | |
| Magneto motor rotor | Bolt | M16 | 1 | 190 | 19 | |
| Right cover | Bolt | M6 | 10 | 10 | 0.1 | |
| Cylinder head cover | Bolt | M6 | 2 | 10 | 0.1 | |
| Cylinder head cover | Nut | M8 | 4 | 26 | 2.6 | |
| Timing sprocket | Bolt | M10 | 1 | 32 | 3.2 | |
| Inlet / exhaust valve cover | Bolt | M6 | 5 | 10 | 1 | |
| Respirator | Bolt | M6 | 2 | 10 | 1 | |
| Timing chain adjuster assy | Bolt | M6 | 2 | 10 | 1 | |
| Water pump | Bolt | M6 | 2 | 10 | 1 | |
| Water pump connection pipe | Bolt | M6 | 2 | 10 | 1 | |
| Peep cover | — | — | — | — | — | |
| Peep cover | — | — | 1 | 10 | 1 | |
| Transmission case | Bolt | M8 | 4 | 26 | 2.6 | |
| Transmission case | Bolt | M10 | 2 | 32 | 3.2 | |
| Connecting plate | Bolt | M10 | 3 | 32 | 3.2 | |
| Clutch | Nut | M14 | 2 | 120 | 12 | |
| Left cover | Bolt | M6 | 10 | 6 | 0.6 | |
| Injector | Bolt | M6 | 1 | 10 | 1 | |
| Air inlet temperature pressure sensor | Bolt | M6 | 1 | 10 | 1 | |
| Throttle body | — | — | — | — | — | |
| Throttle body | — | — | 1 | 6 | 0.6 | |

3.2 PARTS INSPECTION AND SERVICE

3.2.1 VALVE CLEARANCE ADJUSTMENT

NOTE:

Valve clearance adjustment should be made with the engine cool, at room temperature.

When the valve clearance is to be measured or adjusted, the piston must be at Top Dead Center (T.D.C.) on the compression.

1. Remove :
 - Right cover
 2. Remove :
 - Spark plug
 - Valve cover (intake side)
 - Valve cover (exhaust side)
 3. Remove:
 - Timing check plug
 4. Remove:
 - Left cover
 - 5.Measure:
 - Valve clearance
- Out of specification → Adjust.

Valve clearance (cold):

Intake valve **0.12- 0.14m m**
Exhaust valve **0.14- 0.16mm**

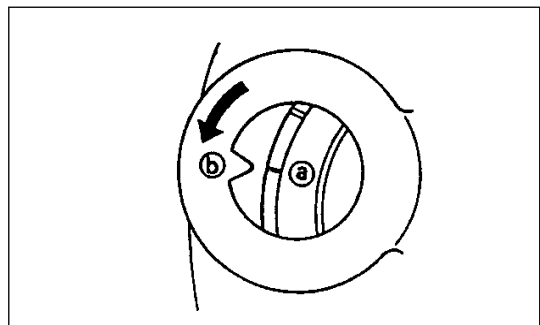

Measurement steps:

- Turn the impeller clockwise to align the mark ① on the rotor of the magneto machine with the mark ② on the right cover.
- Measure the valve clearance by using a feeler gauge.

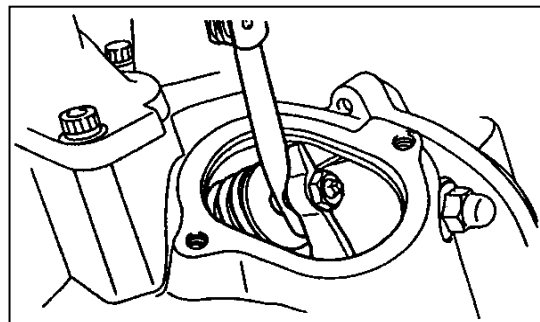



6. Adjust

- Valve clearance

Adjustment steps:

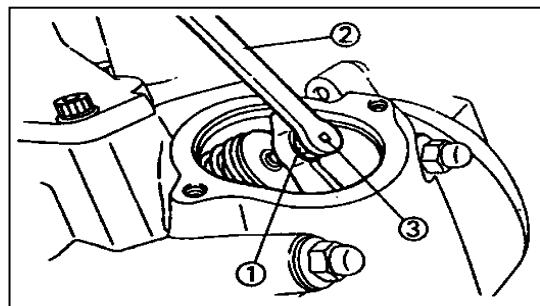
- Loosen the locknut ①
- Turn the adjuster ③ in or out with the valve adjusting tool ② until specified clearance is obtained .
- Turning in → Valve clearance is decreased.
- Turning out → Valve clearance is increased.
- Hold the adjuster to prevent it from moving and



tighten the locknut.  14Nm(1.4m·kg)

- Measure the valve clearance.
- If the clearance is incorrect, repeat above steps until specified clearance is obtained.

7. Install:

- Valve cover (intake side) ①  10Nm(10m·kg)
- O-ring②

8 . Install:

- Valve cover(exhaust side)  10Nm(1.0m·kg)
- O-ring

- Spark plug  18Nm(1.8m·kg)

- Timing check plug

- Right cover  10Nm(1.0m·kg)

9 . Install:

- Left cover  10Nm(1.0m·kg)

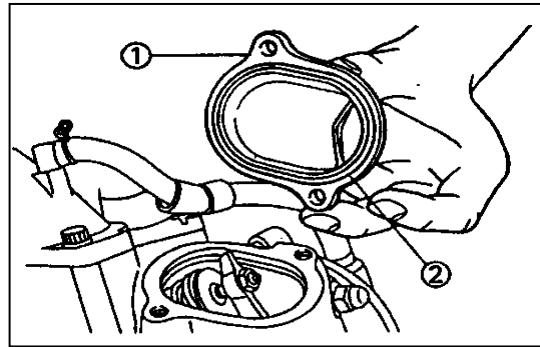

3.2.2 IDLING SPEED ADJUSTMENT

CAUTION:

NO IDLING SPEED ADJUSTMENT

Barring abnormal conditions, the throttle idle screws shall not be adjusted. Otherwise, replace the throttle.

3.2.3 SPARK PLUG INSPECTION

1.Remove :

- Spark plug cap
- Spark plug

CAUTION:

Before removing the spark plug, use compressed air to blow away any dirt accumulated in the spark plug wells to prevent it from falling into the cylinder.

1. Check:

- Spark plug type
- Incorrect → Replace.



**Standard spark plug:
DR8EA(NGK)**

2. Inspect:

- Electrode ①

Wear/ damage → Replace.

- Insulator ②

Abnormal color → Replace.

Normal color is a medium - to- light tan color.

3. Clean:

- Spark plug

(with spark plug cleaner or wire brush)

4. Measure:

- Spark plug gap ③

(with a wire gauge)

Out of specification → Adjust gap.

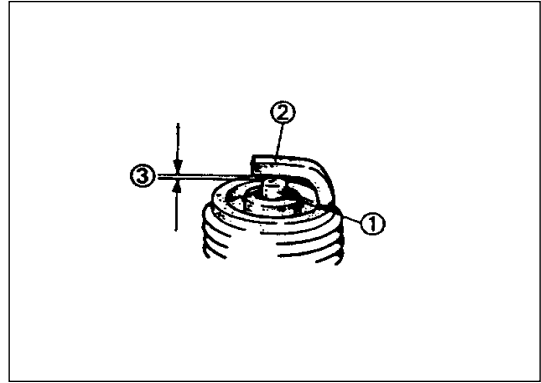

Spark plug gap :
0.6-0.7 mm

6. Install:

- Spark plug

 18Nm(1.8m·kg)

NOTE :

Before installing a spark plug, clean the Gasket surface and plug surface.

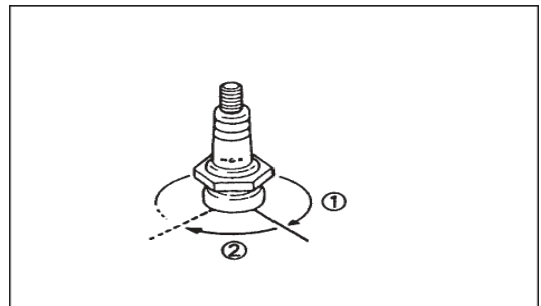

3.2.4 COMPRESSION PRESSURE MEASUREMENT

NOTE :

Insufficient compression pressure will result in performance loss.

1. Check:

- Valve clearance

Out of specification → Adjust.

Refer to “CALCE CLEARANCE ADJUSTMENT” section.

2. Start the engine and let it warm up for several minutes.

3. Turn off the engine.

4. Remove:

- Spark plug

Before removing the spark plug, use compressed air to blow away any dirt accumulated in the spark plug well to prevent it from falling into the cylinder.

5. Attach:

- Compression gauge ①

6. Measure:

- Compression pressure

If it exceeds the maximum pressure allowed → Inspect the cylinder head, valve surfaces and piston crown for carbon deposits.

If it is below the minimum pressure → Squirt a few drops of oil into the affected cylinder and measure again.

Follow the table below.

| Compression pressure (With oil applied into cylinder) | |
|--|---|
| Reading | Diagnosis |
| Higher than without oil | Worn or damaged pistons |
| Same as without oil | Possible defective ring (s), valves, cylinder head gasket or Piston → Repair. |

| | |
|--|---|
|  | Compression pressure(at sea level): |
| | Standard: |
| | 1,400 kPa (14Kg/cm ² , 14 bar) |
| | Minimum : |
| | 1,120 kPa (11.2 kg /cm ² , 11.2 bar) |

Measurement steps :

- Crank the engine with the throttle wide open until reading on the compression gauge stabilizes.

WARNING :

Before cranking the engine, ground all spark plug leads to prevent sparking.

8. Install:

- Spark plug  18Nm(1.8m·kg)

3.2.5 ENGINE OIL LEVEL INSPECTION

1. Start the engine and let it warm up for a few minutes .

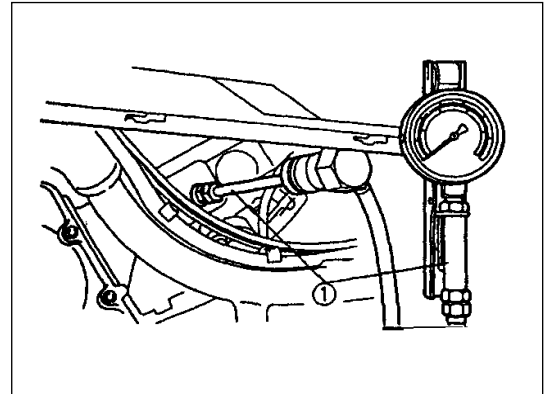

2. Turn off the engine.
3. Inspect: (Do not thread dipstick in)
 - Engine oil level
 Oil level should be between maximum ① and minimum ①marks .
 Oil level is below the minimum mark. Add oil up to the proper lever.

RECOMMENDED ENGINE OIL

Refer to the chart for selection of the oils suited to the atmospheric temperature.

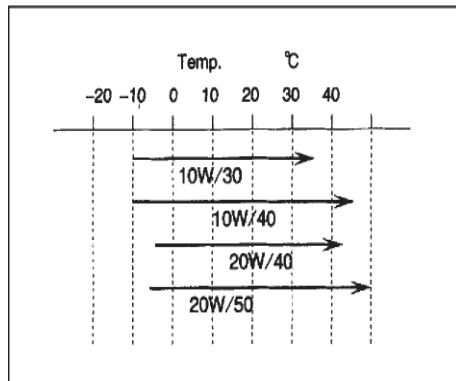

| | |
|---|--|
|  | API STANDARD:API API SE or higher grade |
|---|--|

CAUTION:

- Do not put in any chemical additives or use oils with a grade of CD or higher.
- Be sure not to use oils labeled "ENERGY CONSERVING I" or higher.
 Engine oil also lubricates the clutch and additives could cause clutch slippage.
- Be sure no foreign material enters the crankcase.

4. Start the engine and let it warm up for a few minutes.
5. Turn off the engine.

NOTE:

Wait a few minutes until the oil settles before inspecting the oil level.

ENGINE OIL REPLACEMENT

1. Start the engine and let it warm up for several minutes .
2. Turn off the engine and place an oil pan under the engine.

3. Remove :

- Drain plug ①  32Nm(3.2m·kg)
- Compression spring ②
- Oil strainer ③
- O-ring

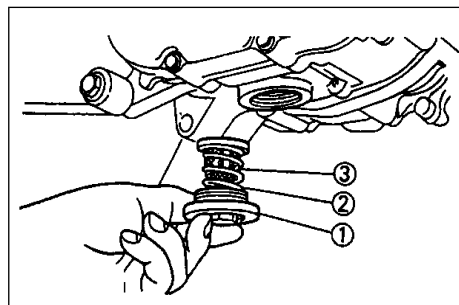

- Drain the crankcase of its oil.

4. Install:

- O-ring ① NEW
- Compression spring ②
- Oil strainer ③
- Drain plug ④

NOTE :

Check the drain plug O-ring. If damaged, replace it with a new one.

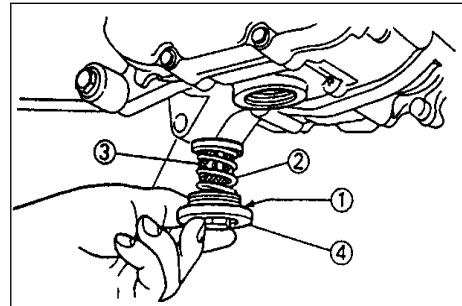

5. Fill:

- Crankcase

| | |
|--|-----------------------|
|  | Oil quantity: 1.4L |
|--|-----------------------|

6. Check:

- Engine oil level
- Refer to "ENGINE OIL LEVEL INSPECTION" section.

ENGINE OIL PRESSURE INSPECTION

Inspection steps:

- Slightly loosen the oil check bolt ①
- Start the engine and keep it idling until the oil begins to seep from the oil check bolt. If no oil comes out after one minute, turn the engine off so it will not seize.

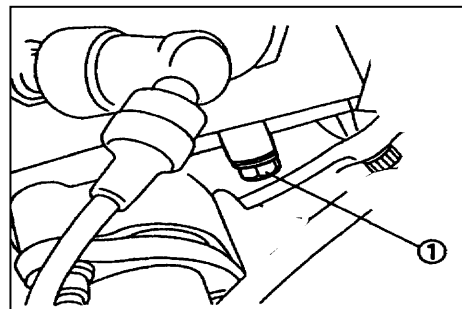

- Check oil passages and oil pump for damage or leakage.

- Start the engine after solving the problem (s), and recheck the oil pressure.

- Tighten the oil check bolt to specification.  10Nm(1.0m·kg)

CAUTION:

- Start the engine and check the oil pressure with the oil check bolt loosened.
- Do not apply at high speeds more than specified when checking the pressure.

NOTE:

Wipe any spilled oil off the engine.

3.2.6 COOLANT LEVEL INSPECTION

Inspect:

- Coolant level

Coolant level should be between the maximum[Ⓐ] and minimum[Ⓑ] marks.

Coolant level is below the "LOWER " level line
Add soft water (tap water) up to the proper level.

CAUTION:

Hard water or salt water is harmful to engine parts.
Use only distilled water if soft water is not available.
If you use tap water, make sure it is soft water.

1. Start the engine and let it warm up for several minutes.
2. Turn off the engine and inspect the coolant level again.

NOTE:

Wait a few minutes until the coolant settles before inspecting the coolant level.

COOLANT REPLACEMENT

1. Remove:

- Front cover of UTV plastic body work.
- Seat.

2. Remove:

- Hose ① (reservoir tank)

Drain the reservoir tank of its coolant.

3. Loosen:

- Engine inlet pipe

- 4.Remove:

- Radiator cap

WARNING:

Do not remove the radiator cap when the engine and radiator are hot. Scalding hot fluid and steam may be blown out under pressure, which could cause serious injury. When the engine has cooled, open the radiator cap as follows:

Place a thick rag or a towel over the radiator cap. Slowly rotate the cap counterclockwise toward the detent. This allows any residual pressure to escape. When the hissing sound has stopped, press down on the cap while turning counterclockwise and remove it.

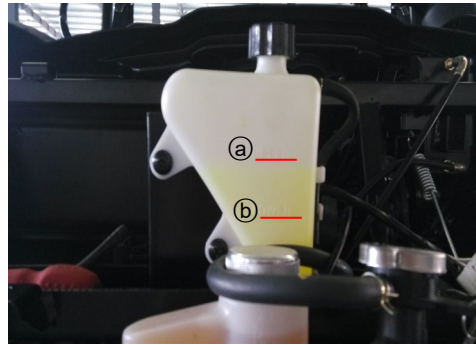

NOTE:

- Remove the radiator cap after loosening engine inlet pipe.

5. Clean:

- Radiator

Fill soft water into the filler neck support (reservoir tank)

6. Connect:

- Hose (reservoir tank)
- Engine inlet pipe ①

7. Fill:

- Radiator (to specified level)

Fill the coolant slowly, until the coolant comes out from the head hose.

- Reservoir tank (to maximum level ①)

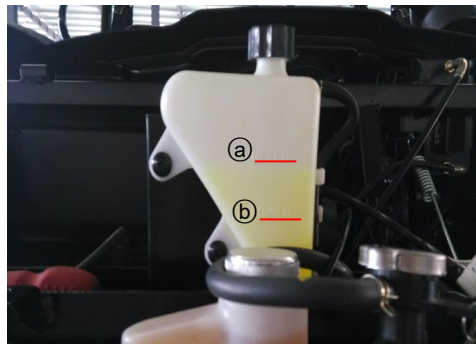
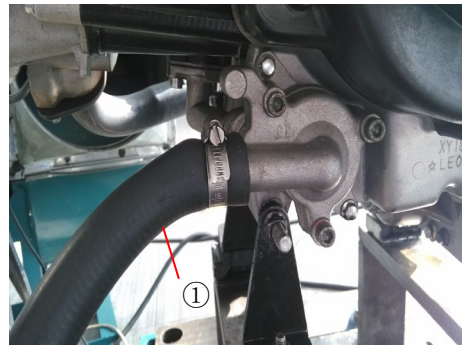

| | |
|---|---|
|  | <p>Recommended coolant: High quality ethylene glycol anti-freeze containing corrosion inhibitors for aluminum engine.</p> |
|---|---|

| | |
|--|---|
|  | <p>Coolant ② and water ③ (soft water) : Mixed ratio: min50% /max50% follow the instruction of the coolant</p> <p>Total amount: 2L</p> <p>Reservoir tank capacity: 0.35L</p> |
|--|---|

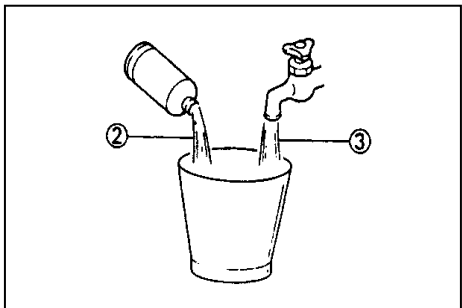

Handling notes for coolant:

Coolant is potentially harmful and should be handled with special care.

WARNING:

Splashes in your eyes:

Thoroughly wash your eyes with water and consult a doctor.

If coolant splashes on your clothes:

- Quickly wash it away with water and then with soap and water.

If coolant is swallowed:

Vomit immediately and see a physician.

CAUTION:

- Hard water or salt water is harmful to engine parts. Use only distilled water if soft water is not available.
- If you use tap water, make sure it is soft water.
- Do not use water containing impurities or oil.
- Take care that no coolant splashes onto painted surfaces. If it does, wash them immediately with water.
- Do not mix different types of ethylene glycol antifreeze containing corrosion inhibitors for aluminum engines.

9. Tighten:

- Hose

Fill the coolant slowly to the specified level.

10. Install:

- Radiator cap

11. Start the engine and let it warm up for several minutes.

12. Stop the engine and inspect the level.

NOTE:

Wait a few minutes until the coolant settles before inspecting the coolant level.

13. Install: Remain parts.

3.3 CYLINDER HEAD AND CYLINDER COMPONENTS

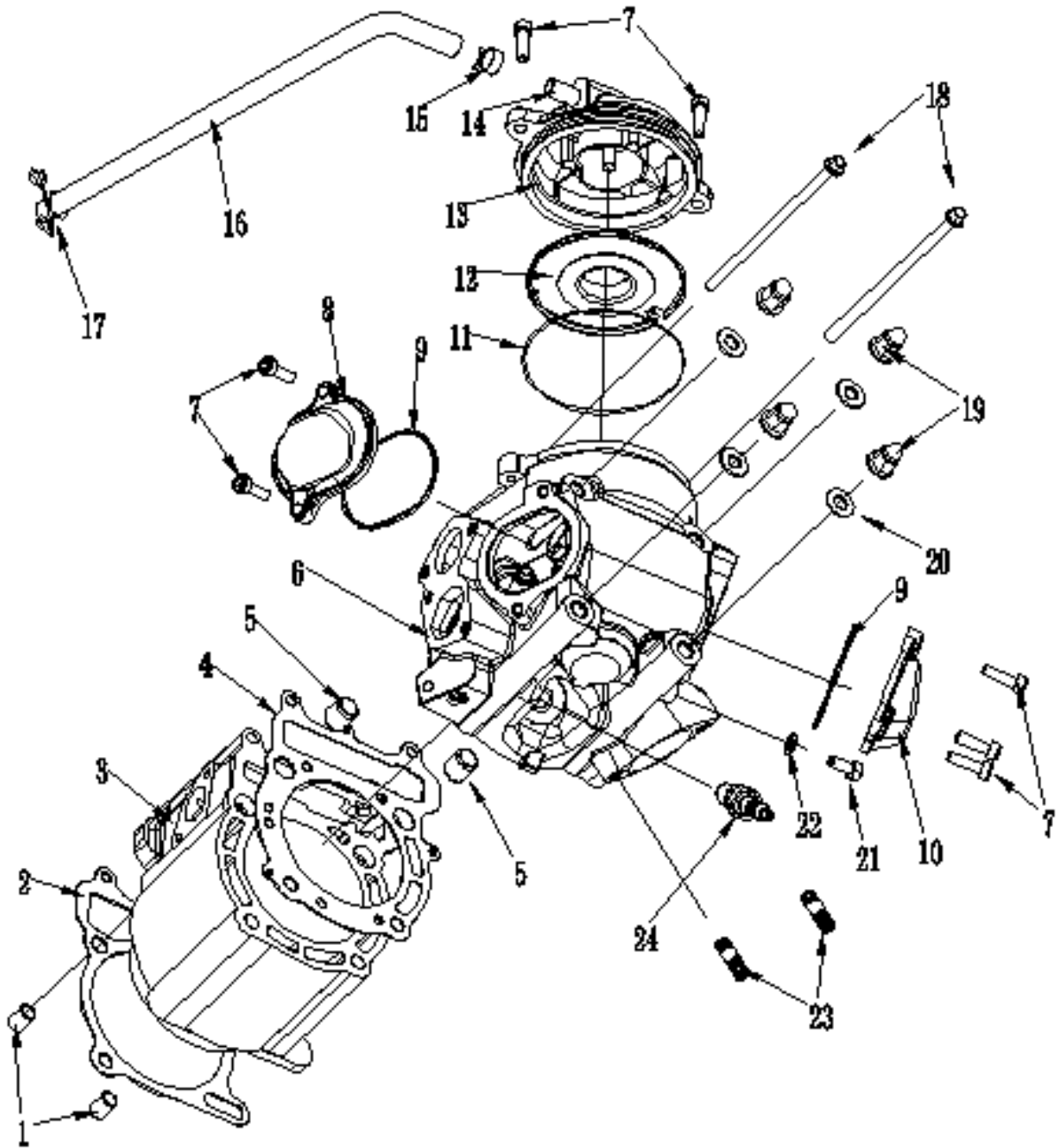

| Order | Job name / Part name | Q 'ty | Remarks |
|-------|--------------------------|-------|-----------------------------|
| | Cylinder head removal | | Remove the parts in order. |
| 1 | Pin dowel 10X14 | 2 | |
| 2 | Cylinder gasket | 1 | |
| 3 | Cylinder | 1 | |
| 4 | Cylinder head gasket | 1 | Refer to " Throttle valve " |
| 5 | Pin dowel 14X16 | 2 | section . |
| 6 | Cylinder head ASSY | 1 | |
| 7 | Bolt socket head M6X20 | 7 | |
| 8 | Valve cover intake side | 1 | |
| 9 | O-ring 57.5X2.3 | 2 | |
| 10 | Valve cover exhaust side | 1 | |
| 11 | O-ring 95X3.3 | 1 | |
| 12 | Breather ASSY I | 1 | |
| 13 | Breather ASSY | 1 | |
| 14 | Pipe joint | 1 | |
| 15 | Clip 13MM | 1 | |
| 16 | Pipe breather 1 | 1 | |
| 17 | Steel wire clamp 15 | 1 | |
| 18 | Bolt flange M6X130 | 2 | |
| 19 | Acorn nuts M8 | 4 | |
| 20 | Washer plate 8 | 4 | |
| 21 | Bolt M6X12 | 1 | |
| 22 | Gasket 6.5 | 1 | |
| 23 | Bolt stud M8X25 | 2 | |
| 24 | Plug spark | 1 | |

CYLINDER HEAD REMOVAL

1. Align:

"I" mark ① on the rotor (with stationary pointer ② on the crankcase cover)

NOTE: If any special mark found, contact the UTV manufacture via the agent for the parts and special instruction.

NOTE:

Turn the primary sheave counterclockwise with a wrench and align the "I" mark ③ with the cylinder head match mark ④ when the piston is at TDC on the compression.

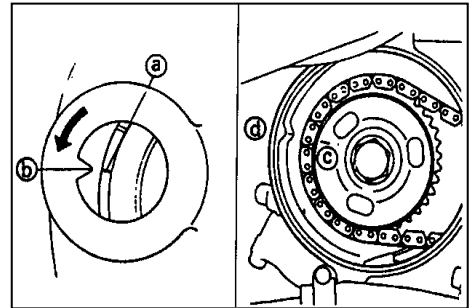

2. Loosen:

- Bolt ①

3. Remove:

- Timing chain tensioner assembly
- Timing chain tensioner gasket

4. Remove:

- Breather plate ②
- Cam sprocket ③
- Timing chain ④

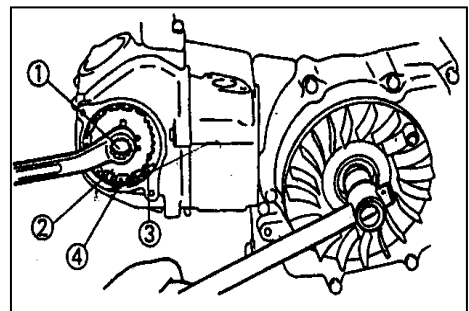

NOTE:

- Fasten a safety wire to the timing chain to prevent it from falling into the crankcase.
- Remove the bolt ① while holding the rotor mounting bolt with a wrench.

5. Remove:

- Cylinder head

NOTE:

- Loosen the nuts in their proper loosening sequence.
- Start by loosening each nut 1/2 turn until all are loose.

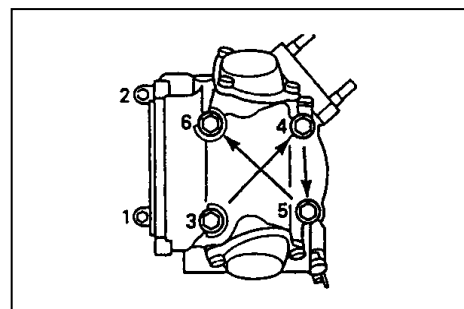

CYLINDER HEAD INSPECTION:

1. Eliminate:

- Carbon deposits (from combustion chambers)
- Use a rounded scraper.

NOTE:

Do not use a sharp instrument to avoid damaging or scratching:

- Spark plug threads
- Valve seats

2. Inspect:

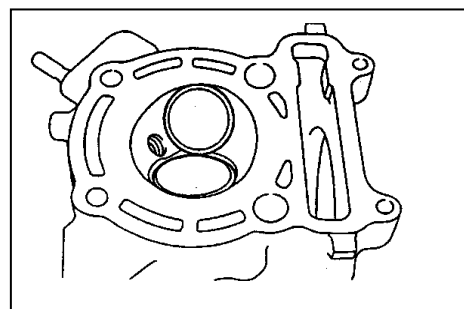

- Cylinder head
Scratches/damage → Replace.

3. Measure:

- Cylinder head warp age
Out of specification → Resurface .

| | |
|--|--|
|  | Cylinder head warpage : Less than 0.03 mm |
|--|--|

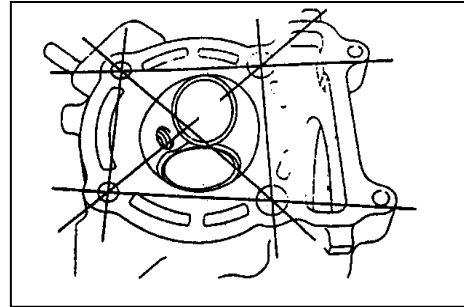

Warpage measurement and resurface ment.

steps: ●Place a straight edge and a feeler gauge across the cylinder head.

- Measure the warpage.
If the warpage is out of specification, resurface the cylinder head.
- Place a 400 ~ 600 grit wet abrasive pape on the surface plate, and resurface the head.

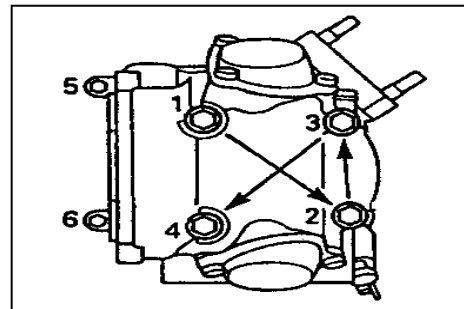

NOTE:

Rotate the cylinder head several times for an even resurface ment. .

CYINDER HEAD INSTALLATION



1. Install:

- Gasket (cylinder head) (NEW)
- Dowel pins
- Cylinder head

NOTE:

- Apply engine oil onto the nut threads.
- Tighten the nuts in a crisscross pattern.

2. Tighten:

- Nuts (cylinder head)  22Nm(2.2m·kg)
- Bolts (cylinder)  10Nm(1.0m·kg)

3. Install:

- Cam sprocket ①
- Timing chain ②

Installing steps :

- Turn the primary sheave counterclockwise until the TDC mark ① matches the stationary pointer ②.
- Align the "I" mark ③ on the cam sprocket with the stationary pointer ④ on the cylinder head.

NOTE: If any special mark found, contact the UTV manufacture via the agent for the parts and

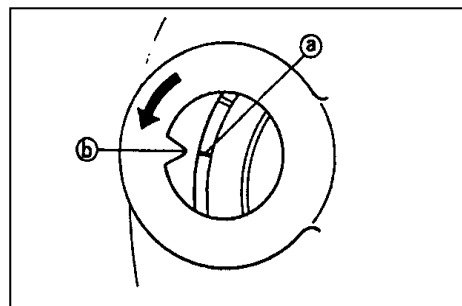
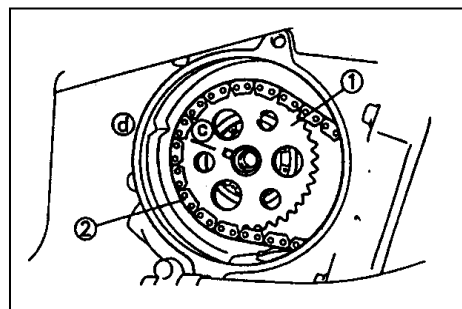

special instruction.

- Fit the timing chain onto the cam sprocket and install the cam sprocket on the camshaft.

NOTE:

- When installing the cam sprocket, keep the timing chain as tense as possible on the exhaust side.

- Align the match mark © on the cam sprocket with the stationary pointer @ on the cylinder head.

- Align the pin on the cam shaft with the slot in the cam sprocket.

CAUTION:

Do not turn the crankshaft during installation of the cam shaft. Dam age or improper valve timing will result.

- While holding the camshaft, temporarily tighten the bolts .
- Remove the safety wire from the timing chain.

4. Install:

- Breather plate ①
- Plane washer ②

5. Install:

- Timing chain tensioner

Installing steps:

- Rotate the hole in the timing chain tensioner with "one letter" to make ① indent, and hold "one letter".
- Install the tensioner with a new gasket ② onto the cylinder.
- Tighten the bolt (with gasket) to the specified torque .
- Put O-ring into the bolt (the timing chain tensioner).
- Tighten the bolt (the timing chain tensioner) to the timing chain tensioner.  8Nm(0.8m·kg)

6. Tighten:

- Bolt (cam sprocket)

7. Check:

- Valve timing
- Out of alignment → Adjust.

8. Check:

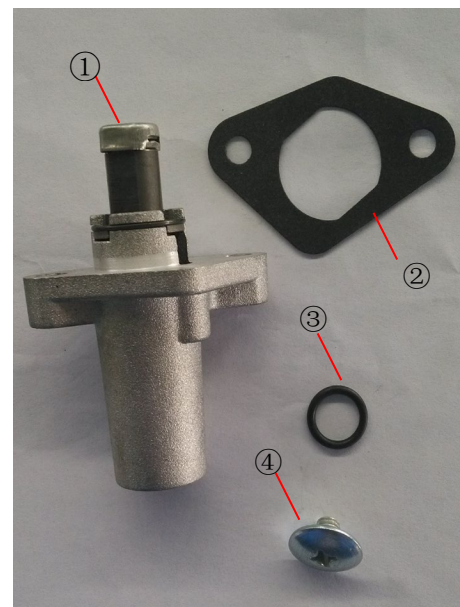
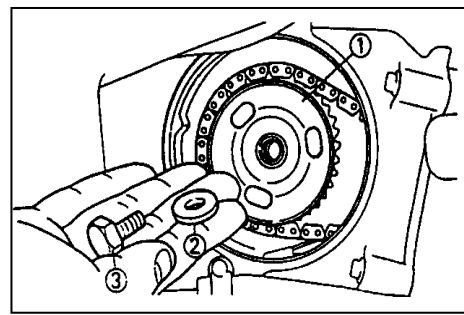

●Valve clearance

Out of specification → Adjust.

Refer to the "VALVE CLEARANC ADJUSTMENT"
section.

3.4CAMSHAFT AND ROCKER ARMS

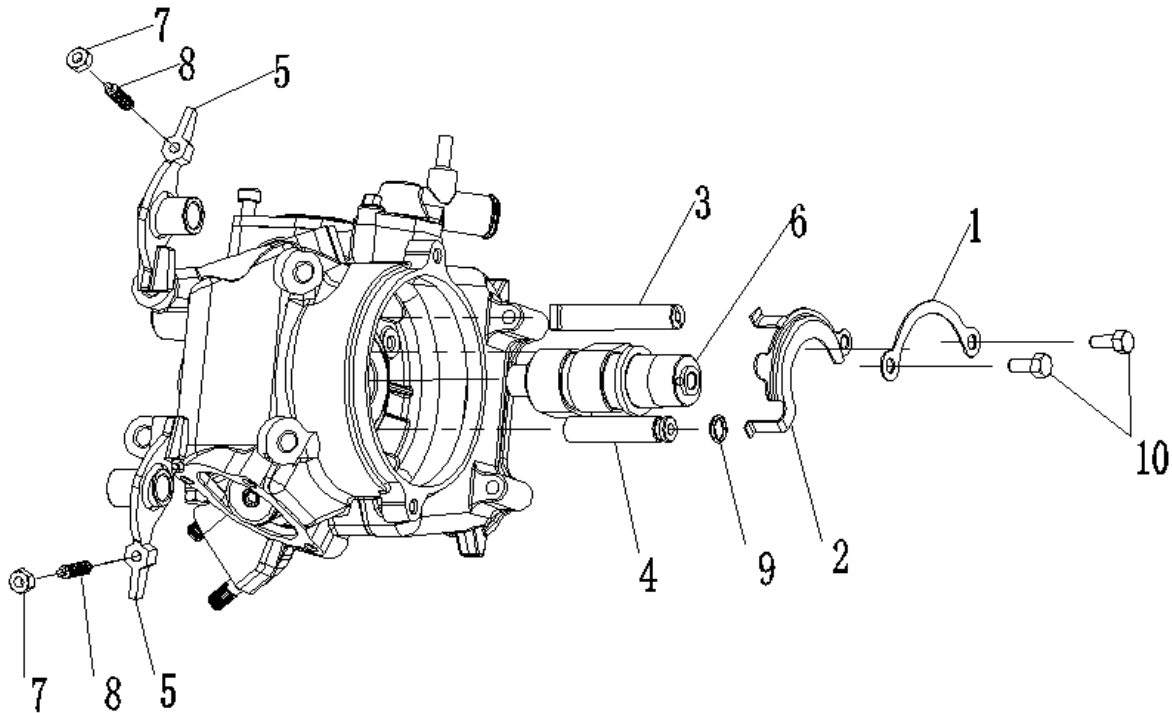

| Order | Job name / Part name | Q 'ty | Remarks |
|-------|--|-------|--|
| | Cam shaft and rocker arms Removal | | Remove the parts in order. Refer to "CYLINDER HEAD" section. |
| 1 | Cylinder head | | |
| 1 | Lock washer | 1 | |
| 2 | Plate | 1 | Refer to "ROCKER ARM AND ROCKER ARM SHAFT REMOVAL AND INSTALLATION" section. |
| 3 | Rocker arm shaft (intake) | 1 | |
| 4 | Rocker arm shaft (exhaust) | 1 | |
| 5 | Rocker arm | 2 | |
| 6 | Camshaft | 1 | Refer to "CAMSHAFT INSTALLATION" section . |
| 7 | Locknut | 2 | |
| 8 | Adjuster | 2 | |
| 9 | O-ring | 1 | |
| | | | Reverse the removal procedure for Installation |

ROCKER ARM AND ROCKER ARM SHAFTRE MOVAL

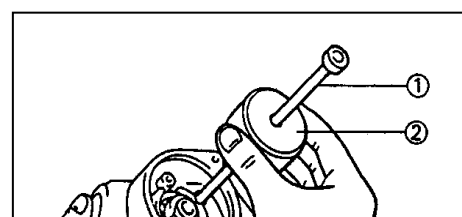

1. Remove:

- Rocker arm shaft (intake)
- Rocker arm shaft (exhaust)

NOTE:

Attach a rocker arm shaft puller bolt ① and weight ② to the rocker arm shaft and slide out the shaft.

CAM SHAFT INSPECTION

1. Inspect:

- Cam lobes
- Pitting/Scratches/Blue discoloration → Replace .

2. Measure:

- Cam lobes length ① and ②
- Out of specification → Replace.



Cam lobes length:

Intake:

- ① 36 .545- 36 .645 mm
<Limit: 36.45 mm>
- ② 30.021-30.121 mm
<Limit: 29.92 mm>

Exhaust:

- ① 36 .547- 36 .647 mm
<Limit: 36.45 mm>
- ② 30.067- 30.167 mm
<Limit: 29.97 mm>

3. Inspect:

- Cam shaft oil passage
- Stuffed → Blow out oil passage with compressed air.

ROCKER ARMS AND ROCKER ARM SHAFTS INSPECTION

1. Inspect:

- Cam lobe contact surface ①
 - Adjuster surface ②
- Wear/Pitting/Scratches/Blue discoloration → Replace.

Inspection steps:

- Inspect the two contact areas on the rocker arms for signs of unusual wear.

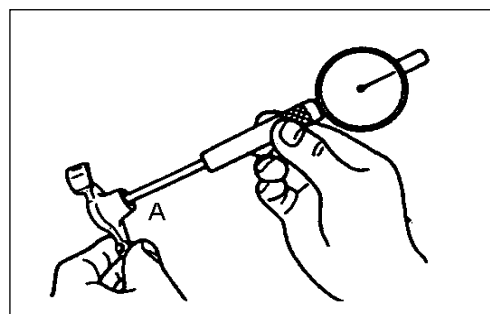
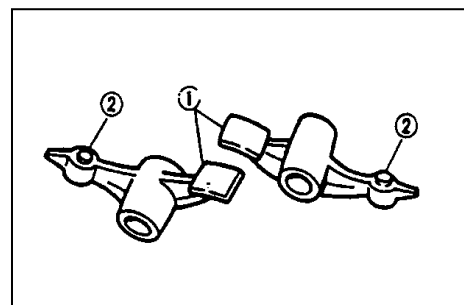
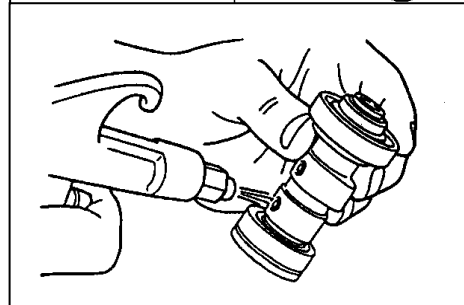
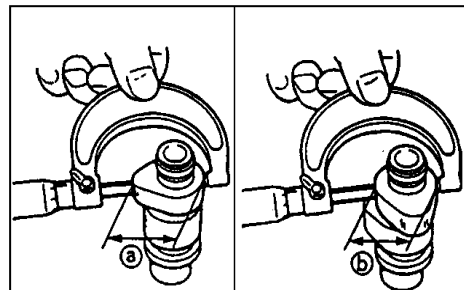
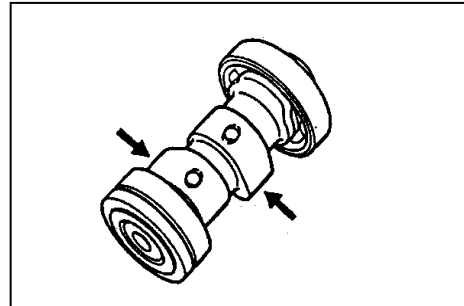

- Rocker arm shaft hole.
- Cam-lobe contact surface.
Excessive wear → Replace.
- Inspect the surface condition of the rocker arm shafts.
Pitting/scratches/blue discoloration → Replace or check lubrication.
- Measure the inside diameter A of the rocker arm holes.
Out of specification → Replace.

| | |
|--|--|
|  | Inside diameter (rocker arm): 12.000- 12.018mm < Lim it: 12.030 mm > |
|--|--|

- Measure the outside diameter B of the rocker arm shafts.
Out of specification → Replace.

| | |
|--|--|
|  | Outside diameter(rocker arm shaft): 11.981-11.991 mm <Lim it: 11.95 mm> |
|--|--|

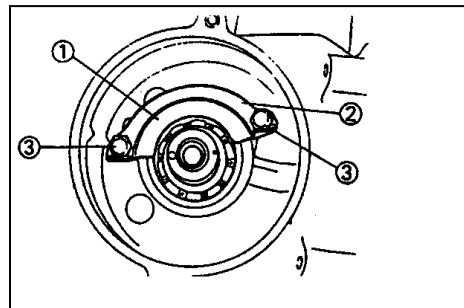
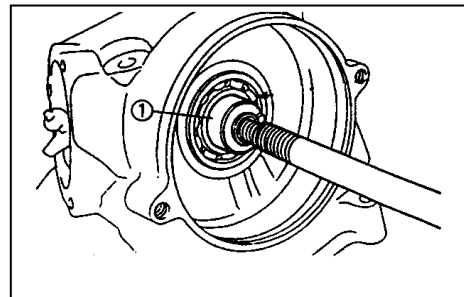
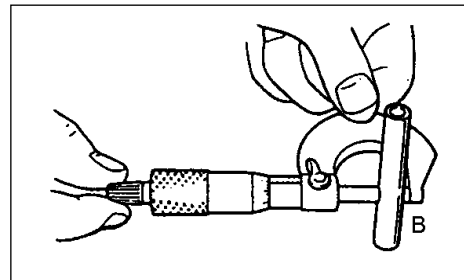

CAMSHAFT AND ROCKER ARM INSTALLATION

1. Lubricate:

- Cam shaft ①

| | |
|--|--|
|  | Camshaft: Molybdenum disulfide oil Camshaft bearing: Engine oil |
|--|--|

2. Install:

- Plate ①
- Lockwasher ② **NEW**
- Bolt ③  8Nm(0.8m·kg)

NOTE:

Bend the lockwasher tabs along the bolt ③ faults.

3. Apply:

- Molybdenum disulfide oil onto the rocker arm and rocker arm shaft.

| | |
|--|---------------------------------|
|  | Molybdenum disulfide oil |
|--|---------------------------------|

4. Install:

- Rocker arm ①
- Rocker arm shaft ② (exhaust)

NOTE:

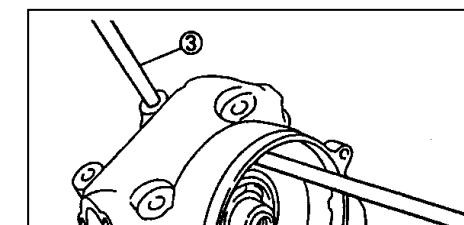
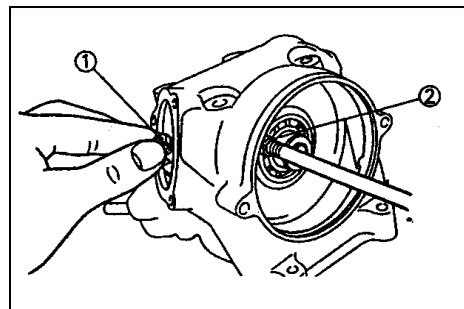

Exhaust:

Install the rocker arm shaft (exhaust) completely pushed in.

5. Install:

- Rocker arm ①
- Rocker arm shaft ② (intake)

NOTE:

Intake:

Insert the guide shaft (8 mm) ③ into the stud bolt hole in the cylinder head to the rocker arm shaft (intake).

CAUTION:

Do not confuse the installation direction of rocker arm shaft. Be sure to install the threaded part facing outward.

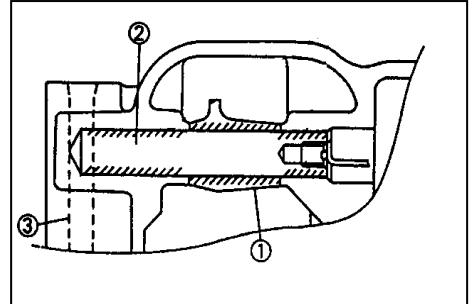

3.5 VALVES AND VALVE SPRINGS

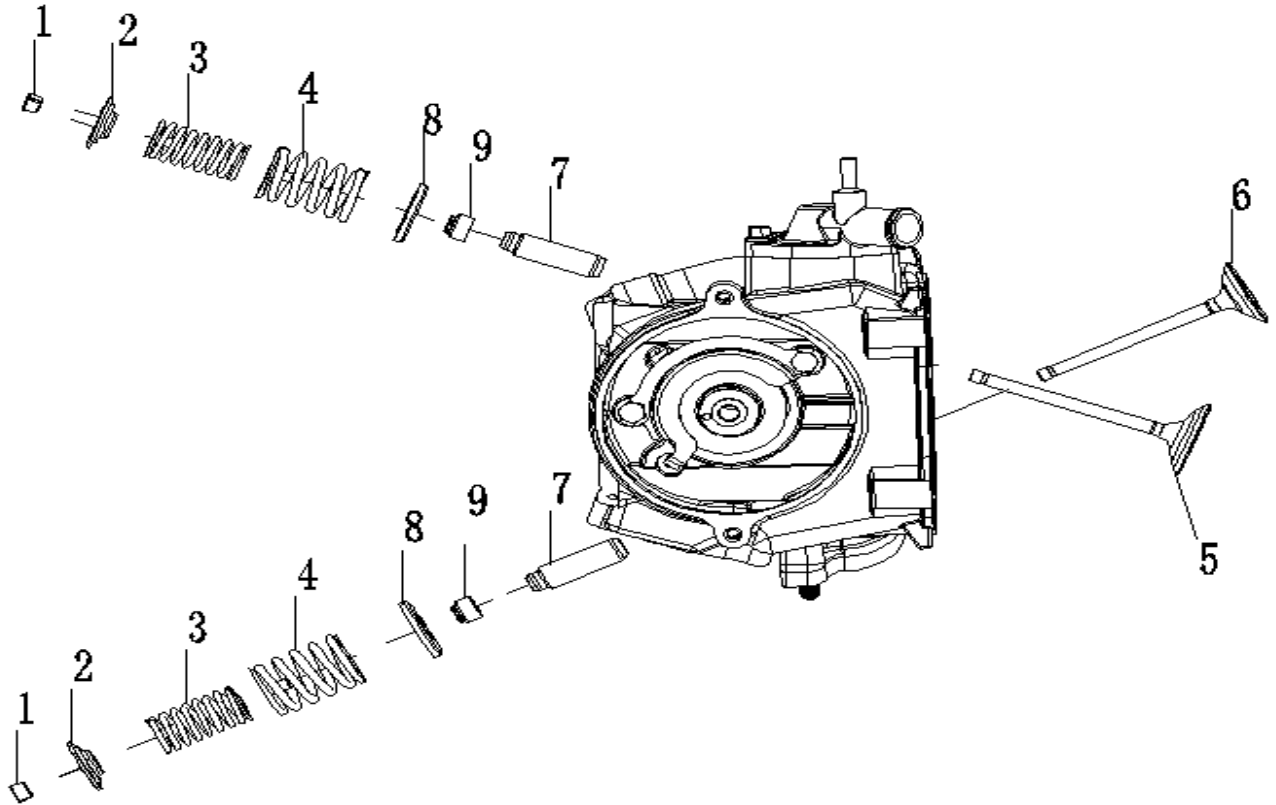

| Order | Job name / Part name | Q 'ty | Remarks |
|-------|---|-------|--|
| | Valves and valve springs removal Cylinder head | | Remove the parts in order. Refer to "CYLINDER HEAD " section . Refer to "ROCKER ARM SHAFT AND ROCKER ARMS" section. |
| 1 | Valve cotters | 4 | Refer to "VALVES AND VALVE SPRINGS REMOVAL/INSTALLATION" section. |
| 2 | Spring retainer | 2 | Refer to "VALVES AND VALVE SPRINGS INSTALLATION" section |
| 3 | Valve spring (inner) | 2 | |
| 4 | Valve spring (Outer) | 2 | |
| 5 | Valve (intake) | 1 | |
| 6 | Valve (exhaust) | 1 | |
| 7 | Valve guide | 2 | |
| 8 | Spring seat | 2 | Reverse the removal procedure for installation |
| 9 | Valve seal | 2 | |

VALVES AND VALVE SPRINGS REMOVAL

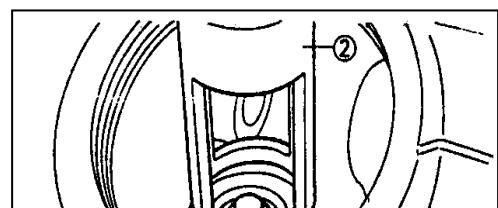

1. Remove:
 - Valve cotters ①

NOTE:

Attach a valve spring compressor and attachment ② between the valve spring retainer and cylinder head to remove the valve cotters.

CAUTION:

Do not compress so much as to avoid damage to the valve spring.

VALVE AND VALVE SPRINGS INSPECTION

1. Measure:
 - Valve stem diameter
 Out of specification → Replace.

| | |
|---|---|
|  | <p>Valve stem diameter:</p> <p>Intake: 5.973-5.995mm <Limit: 5.94mm></p> <p>Exhaust: 5.960-5.975mm <Limit: 5.92mm></p> |
|---|---|

2. Measure:
 - Runout (valve stem)
 Out of specification → Replace.

| | |
|---|---|
|  | <p>● Runout limit: 0.01 mm</p> |
|---|---|

3. Measure:
 - Free length (valve spring)
 Out of specification → Replace.

| | |
|---|---|
|  | <p>Valve spring free length:</p> <p>Inner spring: 38 mm <Limit: 36mm></p> <p>Outer spring: 37.5 mm <Limit: 34.5mm></p> |
|---|---|

4. Measure:

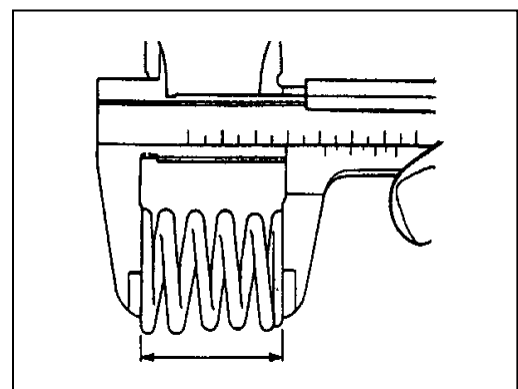
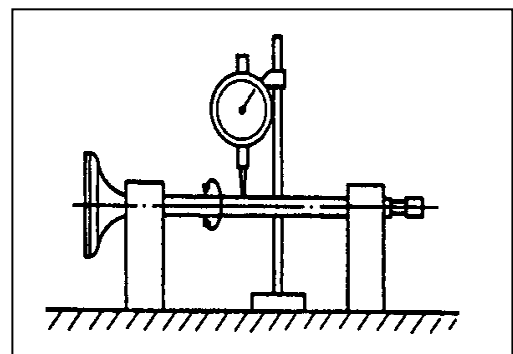
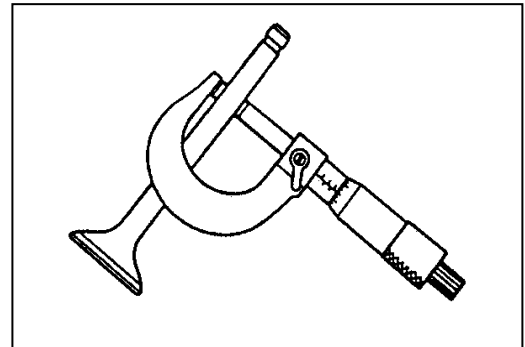

- Spring tilt
- Out of specification → Replace.

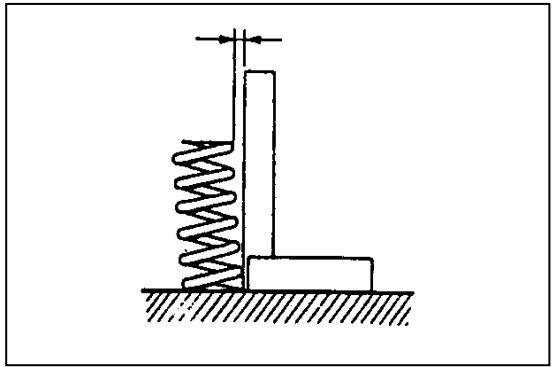

| | |
|--|------------------------------------|
|  | Spring tilt limit: 1.7mm (2.5°) |
|--|------------------------------------|

5. Inspect:
- Spring contact face
- Wear/Pitting/Scratches → Replace.

6. Measure:
- Valve guide inside diameter
- Out of specification → Replace.

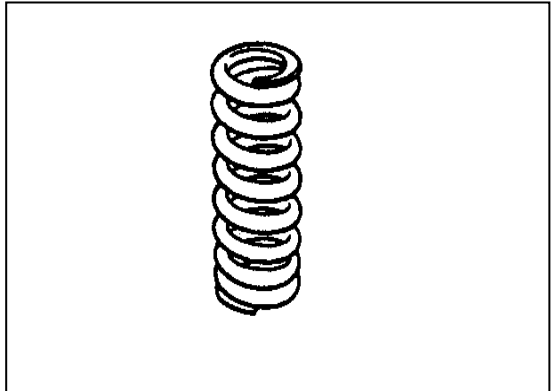

| | |
|--|---|
|  | Valve guide inside diameter: Intake: 6.000-6.012 mm <Limit: 6.05mm> Exhaust: 6.000-6.012 mm <Limit: 6.05 mm> |
|--|---|

7. Measure:
- | |
|--|
| Stem-to guide clearance Valve guide inside diameter Valve stem diameter |
|--|
- Out of specification → Replace the valve guide.

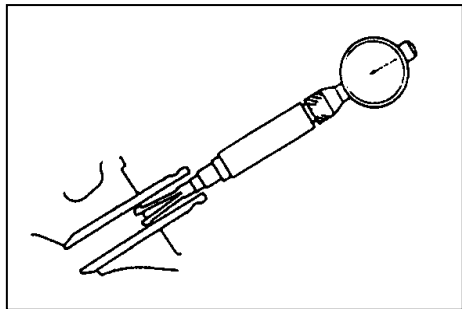

| | |
|--|--|
|  | Stem-to-guide clearance limit: Intake: 0.08 mm Exhaust: 0.10 mm |
|--|--|

VALVE SEATS INSPECTION

1. Eliminate:
- Carbon deposits
(from the valve face and valve seat)
2. Inspect:
- Valve seats
- Pitting/wear → Reface the valve seat.

3. Measure:

- Valve seat width ②
- Out of specification → Reface the valve seat.

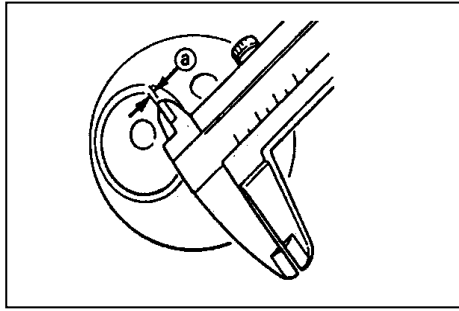

| | |
|--|--|
|  | <p>Valve seat width:</p> <p>Intake:</p> <p>0.9-1.1mm</p> <p><Limit:1.6mm></p> <p>Exhaust:</p> <p>0.9-1.1mm</p> <p><Limit:1.6mm></p> |
|--|--|

Measurement step:

- Apply Mechanic's bluing dye (Dykem)① to the valve face.
- Install the valve into the cylinder head.

Press the valve through the valve guide and onto the valve seat to make a clear pattern.

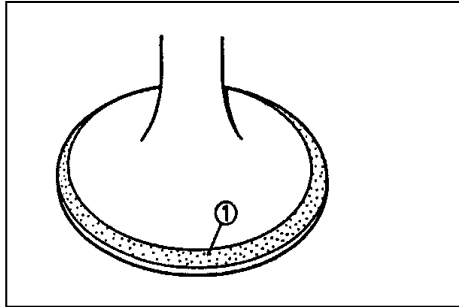

- Measure the valve seat width. Where the valve seat and valve face made contact, bluing will have been removed.

- If the valve seat is too wide, too narrow, or the seat is not centered, the valve seat must be replaced.

4. Lap:

- Valve face
- Valve seat

NOTE:

After replacing the valve seat, valve and valve guide, the valve seat and valve face should be lapped.

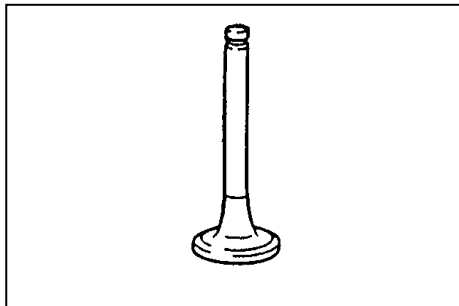

Lapping steps:

- Apply a coarse lapping compound ② to the valve face.

CAUTION:

Do not let compound enter the gap between the valve stem and the guide.

- Apply molybdenum disulfide oil to the valve stem.
- Install the valve into the cylinder head.
- Turn the valve until the valve face and valve seat are evenly polished, then clean off all compound.

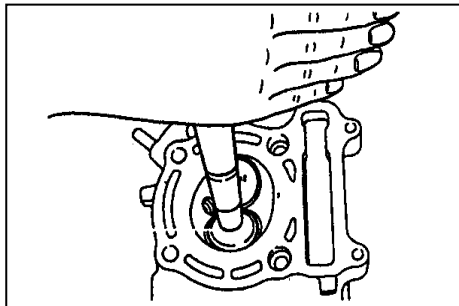

NOTE:

For best lapping results, lightly tap the valve seat while rotating the valve back and forth between your hand.

- Apply a fine lapping compound to the valve face and repeat the above steps.

NOTE:

Make sure to clean off all compound from the valve face and valve seat after every lapping operation.

- Apply Mechanic's bluing dye (Dykem) ⑥ to the valve face.

- Install the valve into the cylinder head.

- Press the valve through the valve guide and onto the valve seat to make a clear pattern.

- Measure the valve seat with ③ again.

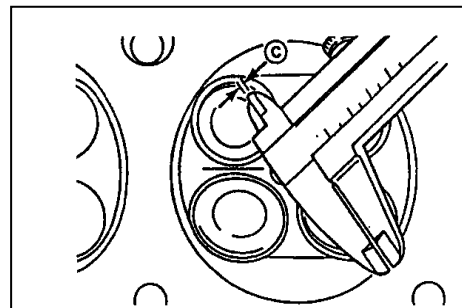
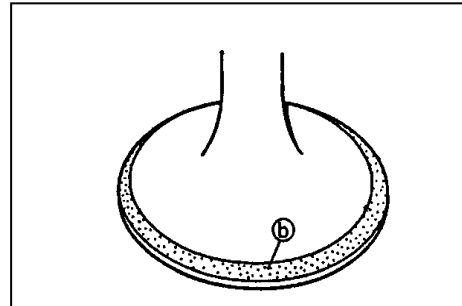

VALVES AND VALVE SPRINGS INSTALLATION

1. Deburr:

- Valve stem end

Use an oilstone to smooth the stem end.

2. Apply:

- Molybdenum disulfide oil (onto the valve stem ③ and oil seal ②)

3. Install:

- Valve spring seat ①
- Valve stem seal ② (NEW)
- Valve ③ (into the cylinder head)
- Valve spring (under) ④
- Valve spring (outer) ⑤
- Spring retainer ⑥

NOTE:

Install the valve spring with the larger pitch ④ facing upwards.

⑥ Smaller pitch

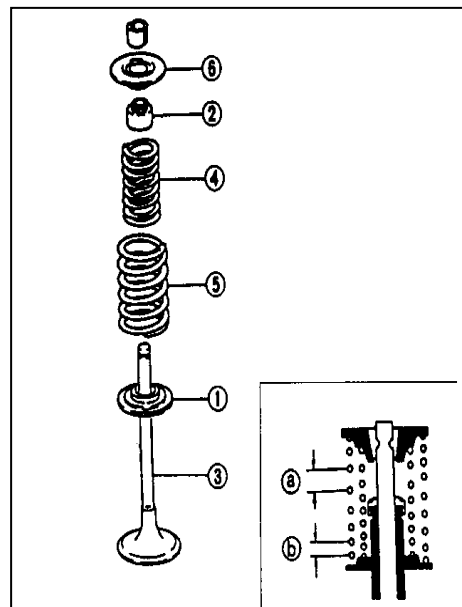

| | |
|--|---------------------------------|
|  | Molybdenum disulfide oil |
|--|---------------------------------|

4. Install:

- Valve cotters ①

NOTE:

Install the valve cotters while compressing the valve spring with a valve spring compressor and attachment ②.

5. Secure the valve cotters onto the valve stem by tapping lightly with a piece of wood.

CAUTION:

Do not hit so much as to damage the valve.

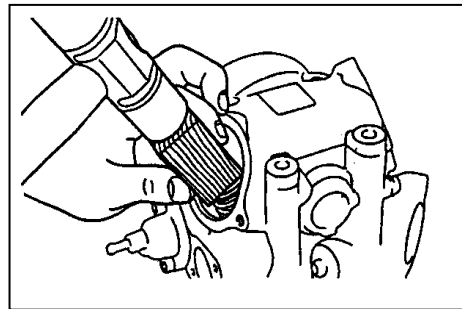
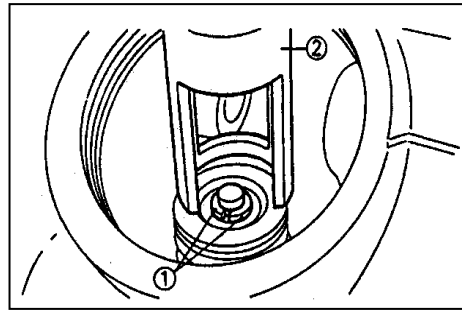

3.6 CYLINDER AND PISTON

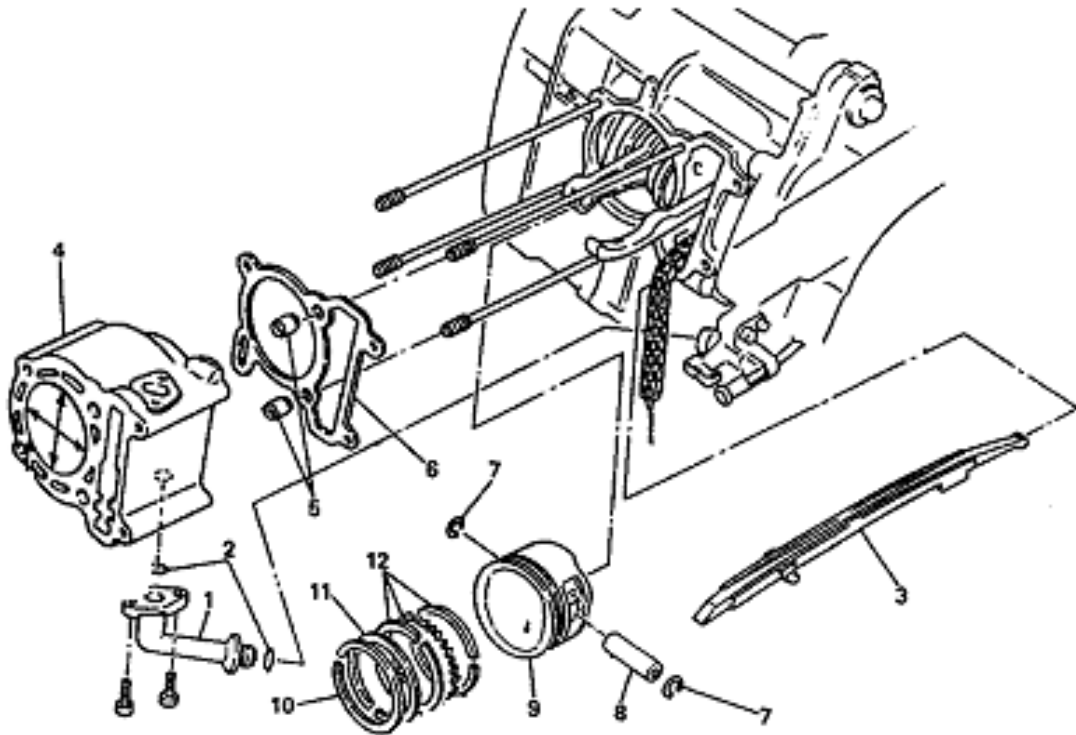

| Order | Job name / Part name | Q 'ty | Remarks |
|-------|-----------------------------------|-------|---|
| | Cylinder and piston removal | | Remove the parts in order. |
| | Cylinder head | | Refer to " CYLINDER HEAD " |
| 1 | Joint | 1 | section . |
| 2 | O-ring | 2 | |
| 3 | Timing chain guide (exhaust side) | 1 | Refer to " PISTON RINGS, |
| 4 | Cylinder | 1 | PISTON AND CYLINDER |
| 5 | Dowel pin | 2 | |
| 6 | Cylinder gasket | 1 | |
| 7 | Piston pin circ lip | 2 | Refer to "PISTON AND |
| 8 | Piston pin | 1 | PISTON RINGS REMOVAL" |
| 9 | Piston | 1 | section . |
| 10 | Piston ring (top) | 1 | Refer to "PISTON RINGS, |
| 11 | Piston ring (2nd) | 1 | PISTON AND CYLINDER |
| 12 | Side rail/Spacer | 2/1 | INSTALLATION " section . |
| | | | Reverse the removal procedure for installation |

PISTON AND PISTON RINGS REMOVAL

1. Remove:

- Piston pin circ lip ①
- Piston pin ②
- Piston ③

NOTE:

Before removing the piston pin circ lip, cover the crankcase opening with a clean tow el or rag to prevent the circ lip from falling into the crankcase cavity.

2. Remove:

- Top ring
- 2nd ring
- Oil ring

NOTE:

When removing the piston ring, open the end gap of the ring by fingers, and push up the other side of the ring.

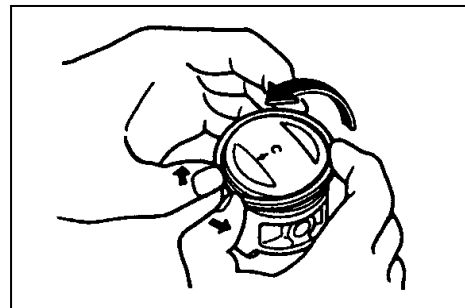
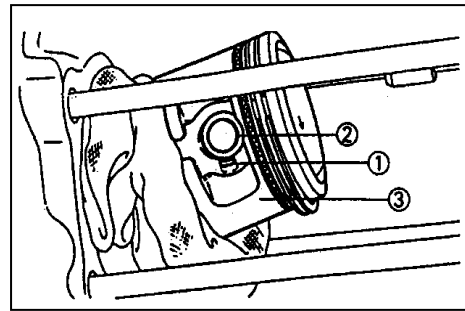

CYLINDER INSPECTION

1. Measure:

- Cylinder bore

Out of specification → Rebore or replace.

NOTE:

●Measure the cylinder bore with a cylinder bore gauge.

●Measure the cylinder bore in parallel to and a right angle to the crankshaft. Then, find the average of the measurements.

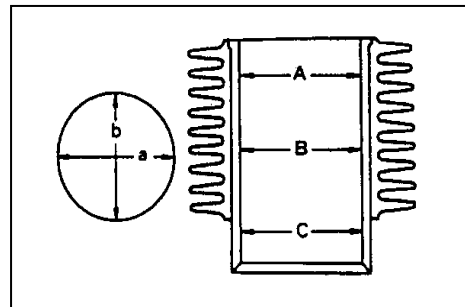

| | |
|--|---|
|  | <p>Cylinder bore: 82.000- 82.014mm < Limit:82.025mm> < Difference limit between A,B and C :0.03m m ></p> |
|--|---|

2. Measure:

- Warpage

Out of specification → Replace.

| | |
|--|--|
|  | <p>Cylinder warpage limit: 0.03mm</p> |
|--|--|

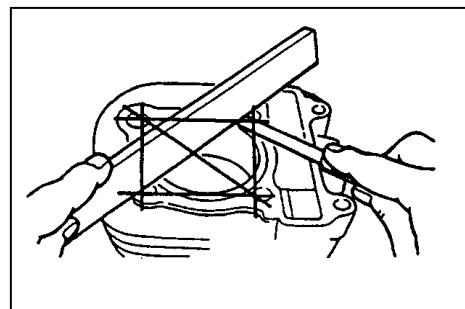

PISTON AND PISTON PIN INSPECTION

1. Measure:

- Piston skirt diameter

Out of specification → Replace .

Ⓐ 5.0mm from the piston bottom edge.

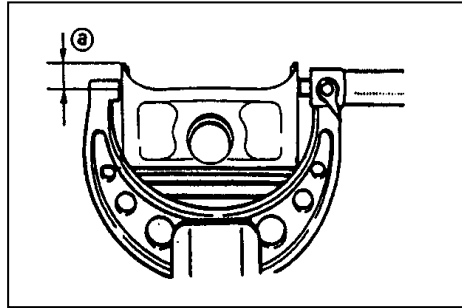

| | |
|--|---|
|  | Valve skirt diameter: 81.965-81.980 mm |
|--|---|

2. Calculate:

- Piston-to-cylinder clearance

| |
|---|
| Piston-to-cylinder clearance Cylinder bore-Piston skirt diameter |
|---|

Refer to “CYLINDER” section for cylinder bore measurement.

Out of specification → Replace the piston and piston rings as a set.

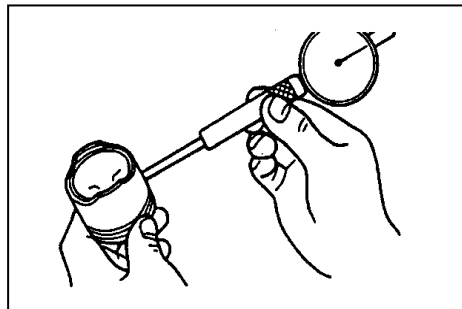

| | |
|--|--|
|  | Piston-to-cylinder clearance: 0.02-0.04mm |
|--|--|

3. Measure:

- Piston pin bore diameter

Out of specification → Replace.

| | |
|--|---|
|  | Piston pin bore diameter: 18.000-18.015mm <Limit:18.045mm> |
|--|---|

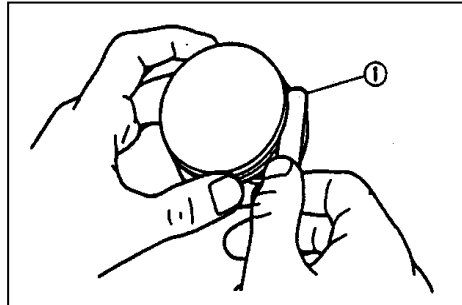

4. Measure:

- Piston pin outside diameter

Out of specification → Replace.

| | |
|--|---|
|  | Piston pin bore diameter: 17.994-18.005mm <Limit:17.975mm> |
|--|---|

5. Inspect:

- Piston pin

Blue discoloration/groove → Clean or replace.

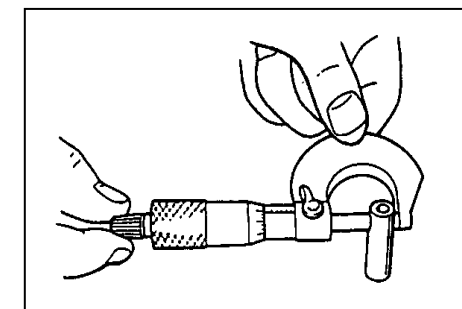

PISTON RINGS INSPECTION

1. Measure:

- Side clearance ①

Out of specification → Replace the piston and the piston rings as a set.

NOTE:

Eliminate the carbon deposits from the piston ring grooves and rings before measuring the side clearance.

| | |
|--|---|
|  | <p>Side clearance (piston ring):</p> <p>Top ring: 0.04- 0.08m m <Limit: 0.12mm></p> <p>2nd ring: 0.03 - 0.07mm <Limit: 0.12mm></p> |
|--|---|

2.Position:

- Piston ring into the cylinder

NOTE :

Push the ring with the piston crown so that the ring will be at a right angle to the cylinder bore.

① 5.0mm

3. Measure:

- End gap
- Out of specification → Replace.

NOTE:

You cannot measure the end gap on the expander spacer of the oil ring. If the oil ring rails show excessive gap, replace all three rings.

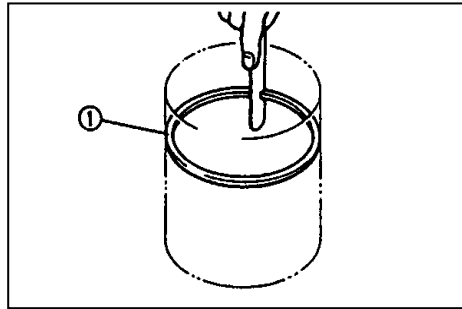

| | |
|--|--|
|  | <p>End gap:</p> <p>Top ring: 0.15-0.30mm <Limit:0.45mm></p> <p>2nd ring: 0.30-0.45mm <Limit:0.70m m></p> <p>Oil ring: 0.20-0.70mm</p> |
|--|--|

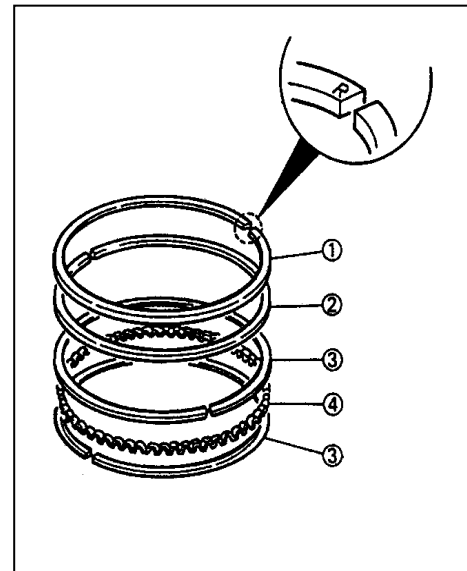

PISTON RINGS, PISTON AND CYLINDER INSTALLATION

1. Install:

- Top ring ①
- 2nd ring ②
- Side rails (oil ring) ③
- Expander spacer (oil ring) ④

NOTE:

●Make sure to install the piston rings so that the manufacturer's marks or numbers are located on the upper side of the rings.

●Lubricate the pistons and piston rings liberally with engine oil.

3. Install:

- Piston ①
- Piston pin ②
- Piston pin clip ③ NEW

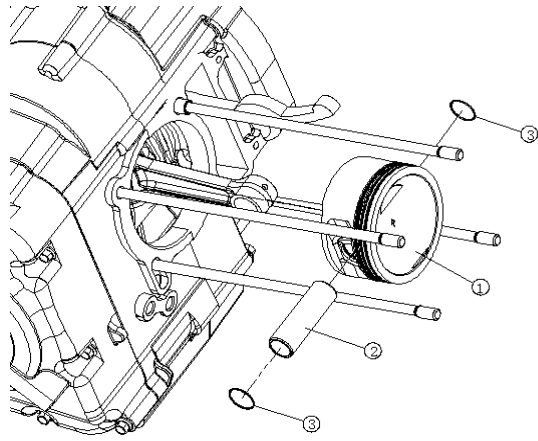

NOTE:

- Apply engine oil to the piston pins.
- The " → " mark ④ on the piston must face the intake side of the cylinder.

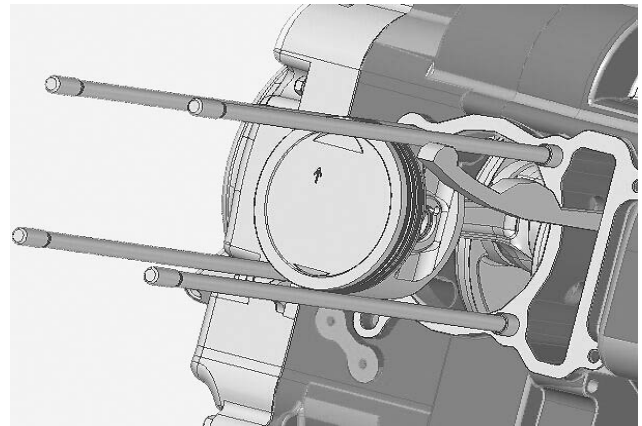

4. Position:

- Piston rings

NOTE: 注

Offset the piston ring end gaps as shown.

- ④ Top ring end
- ⑥ Oil ring end (lower)
- ⑦ Oil ring end (upper)
- ⑧ 2nd ring end

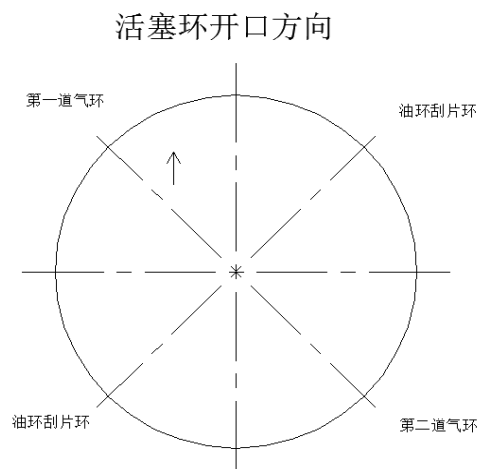

5. Lubricate:

- Piston outer surface
- Piston ring
- Cylinder inner surface

| | |
|--|-------------------|
| | Engine oil |
|--|-------------------|

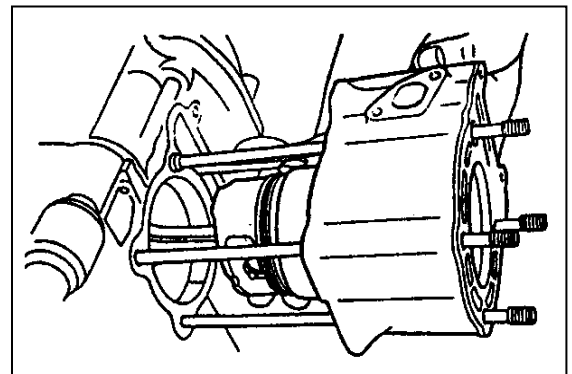

- 6. Install:
- Cylinder

NOTE:

- Install the cylinder with one hand while com pressing the piston rings with the other hand.
- Pass the timing chain and timing chain guide (exhaust side) through the timing chain cavity.

3.7V-BELT,CLUTCH AND SECONDARY/PRIMARY SHEAVE
CRANKCASE COVER (LEFT)

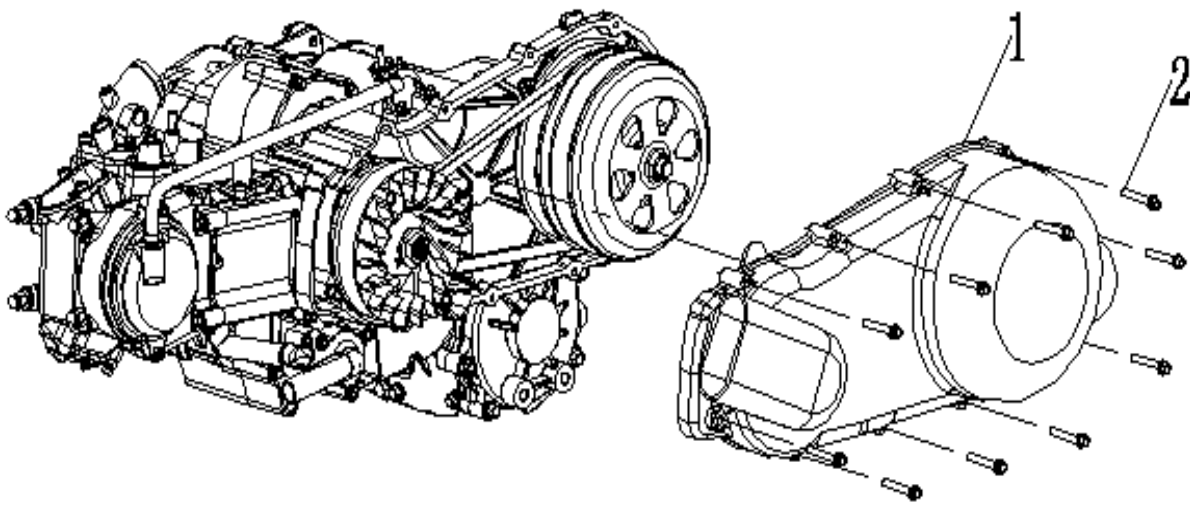

| Order | Job name / Part name | Q 'ty | Remarks |
|-------|----------------------|-------|--|
| 1 | Left cover removal | | Remove the parts in order. |
| 2 | Left cover | 1 | |
| | Bolt | 10 | Reverse the removal procedure for installation . |

PRIMARY SHEAVE

*Apply molybdenum disulfide grease

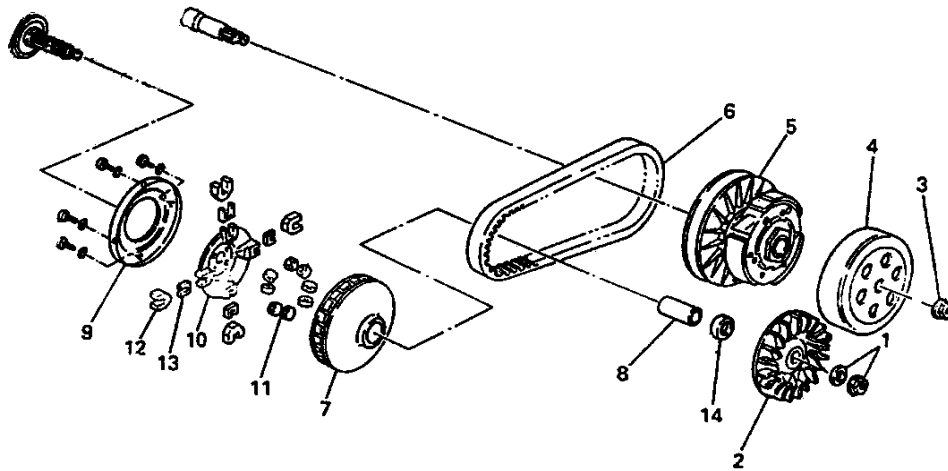

| Order | Job name / Part name | Q 'ty | Remarks |
|-------|---|-------|---|
| | V-belt, clutch and secondary/ primary sheave removal | | Remove the parts in order |
| 1 | Nut/Plain washer | 1/1 | Refer to "PRIMARY SHEAVE REMOVAL" section. |
| 2 | Primary fixed sheave | 1 | |
| 3 | Nut | 1 | Refer to "SECONDARY SHEAVE AND V-BELT REMOVAL" section. |
| 4 | Clutch housing | 1 | |
| 5 | Clutch assembly | 1 | |
| 6 | V-belt | 1 | Refer to "SECONDARY SHEAVE INSTALLATION" section. |
| 7 | Primary sliding sheave | 1 | |
| 8 | Collar | 1 | |
| 9 | Primary sheave cap | 1 | Refer to "PRIMARY SHEAVE ASSEMBLY" section. |
| 10 | Cam | 1 | |
| 11 | Weight | 8 | |
| 12 | Slider | 4 | Refer to "PRIMARY SHEAVE ASSEMBLY" section. |
| 13 | Spacer | 4 | |
| 14 | Oil seal | 1 | Reverse the removal Procedure for installation. |

SECONDARY SHEAVE

**Apply lightweight lithium-soap base grease

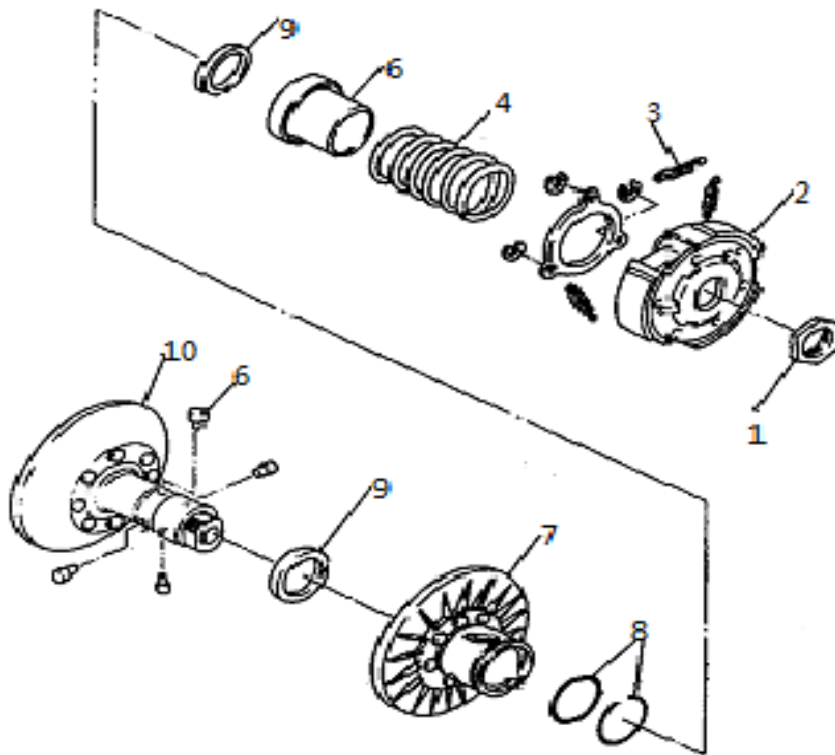

| Order | Job name / Part name | Q 'ty | Remarks |
|-------|------------------------------|-------|---|
| | Secondary sheave disassembly | | Disassemble the parts in order. |
| 1 | Nut | 1 | |
| 2 | Clutch carrier | 1 | Refer to "SECONDARY SHEAVE DISASSEMBLY" section. |
| 3 | Clutch shoe spring | 3 | |
| 4 | Compression spring | 1 | |
| 5 | Spring seat | 1 | Refer to "SECONDARY SHEAVE INSTALLATION " section . |
| 6 | Guide pin | 4 | |
| 7 | Secondary sliding sheave | 1 | |
| 8 | O-ring | 2 | Refer to "SECONDARY SHEAVE INSTALLATION" section. |
| 9 | Oil seal | 2 | |
| 10 | Secondary fixed sheave | 1 | Reverse the disassembly procedure for assembly. |

PRIMARY SHEAVE REMOVAL

1. Remove:

- Nut ①(primary sheave)
- Plate washer
- Primary fixed sheave②

NOTE:

Loosen the nut (primary fixed sheave) while holding the primary fixed sheave with the rotor holder③.

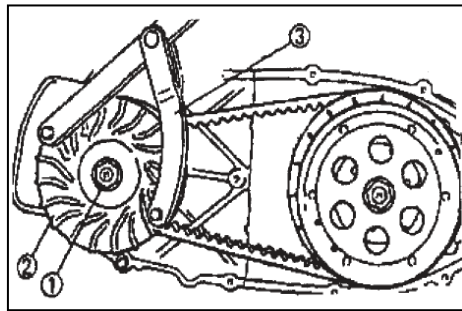

SECONDARY SHEAVE AND V-BELT REMOVAL

1. Remove:

- Nut ① (secondary sheave)
- Clutch housing ②

NOTE:

Loosen the nut (secondary sheave) while holding the clutch housing with the sheave holder③.

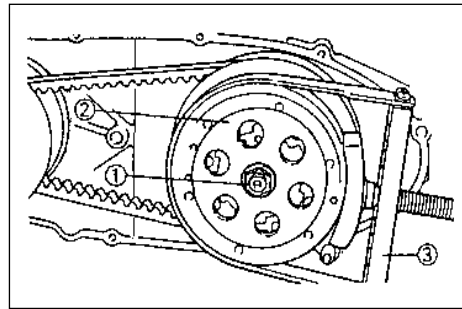

2. Remove:

- Nut ① (clutch carrier)

CAUTION:

Do not remove the nut (clutch carrier) yet.

NOTE:

Loosen the nut (clutch carrier) one turn using the locknut wrench ③ while holding the clutch carrier with the rotor holder②.

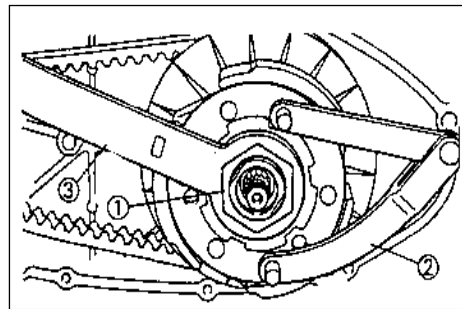

3. Remove:

- Clutch assembly ①
- V-belt ②

NOTE:

Remove the V-belt from the primary sheave side with clutch assembly.

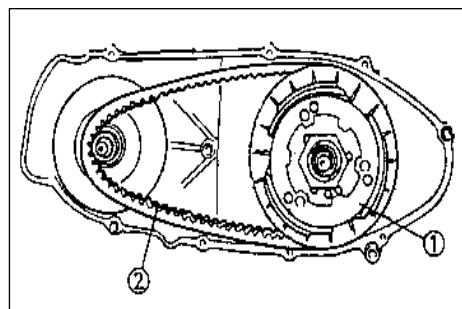

SECONDARY SHEAVE DISASSEMBLY

1. Remove:

- Nut ① (secondary sheave)

NOTE:

Loosen the nut ① while attaching the clutch spring compressor ② and clutch spring holder arm ③ and release the compressed spring after removing the nut.

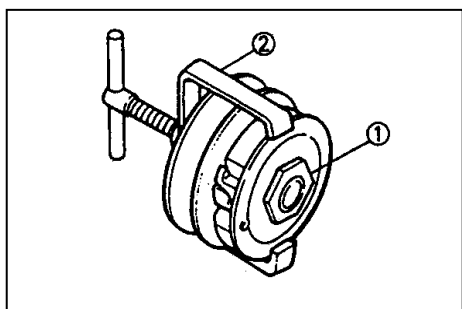

CAUTION:

Use the spacer ④ (diameter: Φ 30mm ; thickness: 2-3mm).

CLUTCH INSPECTION

1.Measure:

- Clutch shoe thickness

Scratches → Glaze using coarse sandpaper.

Wear /Damage → Replace

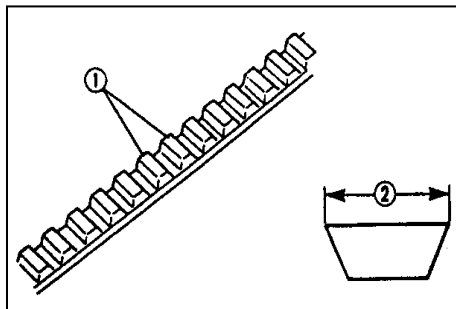
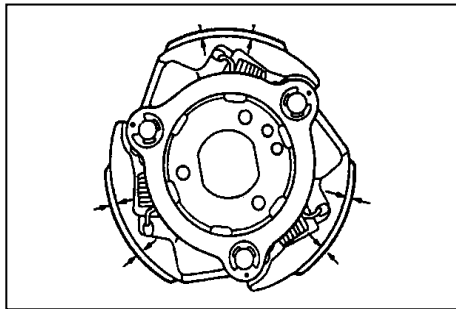
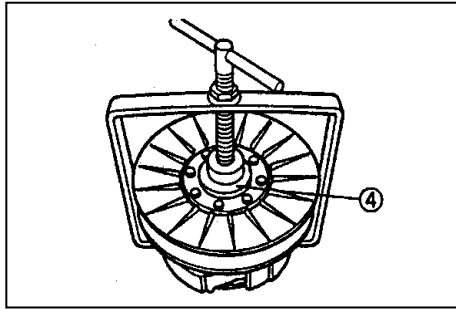

| | |
|--|---|
|  | <p>Clutch shoe thickness: 3.0mm <Limit:2.0mm></p> |
|--|---|

NOTE:

- After using the sandpaper, clean off the polished particles.

- Inspect the other clutch shoes.

- Replace all three as a set.

V-BELT INSPECTION

1.Inspect:

- V-belt ①

Cracks/Wear /Scaling /Chipping → Replace.

Oil/Grease → Check primary sheave and secondary sheave.

2. Measure:

- V-belt width ②

Out of specification → Replace

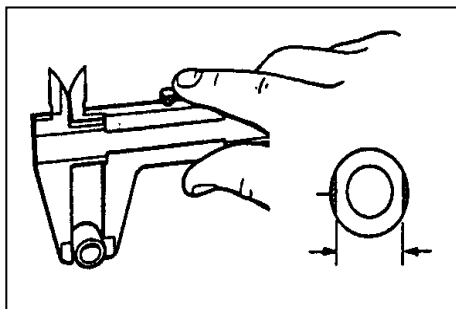

| | |
|--|--|
|  | <p>V-belt width: 22.6mm (Limit:21.0mm)</p> |
|--|--|

ROLLER INSPECTION

1. Inspect:

- Roller minimum outside diameter

Cracks/Wear /Scaling /Chipping → Replace.

Out of specification → Replace

| | |
|--|---|
|  | <p>Roller outside diameter: 20.0 mm <Limit: 19.5mm></p> |
|--|---|

SECONDARY SHEAVE INSPECTION

1. Inspect:

- Secondary fixed sheave smooth operation
- Secondary sliding sheave smooth operation

2. Inspect:

- Torque cam groove ①

Wear /Damage → Replace.

3. Inspect:

- Guide pin ②

Wear /Damage → Replace.

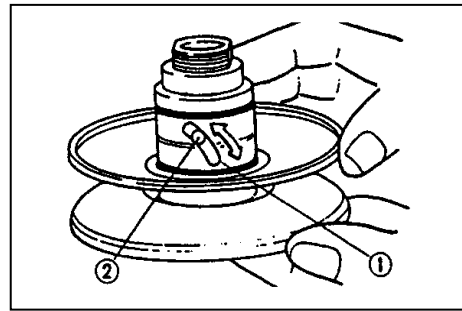

PRIMARY SHEAVE ASSEMBLY

1. Clean:

- Primary fixed sheave face ②
- Collar ③
- Weight ④
- Primary sliding sheave cam face

NOTE:

Remove any excess grease.

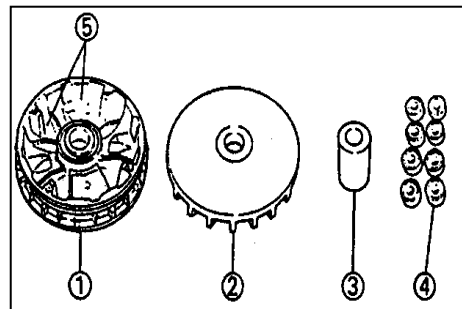

2. Install:

- Roller ①
- Collar ②

NOTE:

●Apply molybdenum disulfide grease to all of the outside of the roller and install.

●Apply lightweight lithium-soap base grease to the inside of the collar.

3. Install:

- Spacer ①
- Slider ②
- Cam ③
- Primary sliding sheave cap. 3Nm(0.3m·kg)

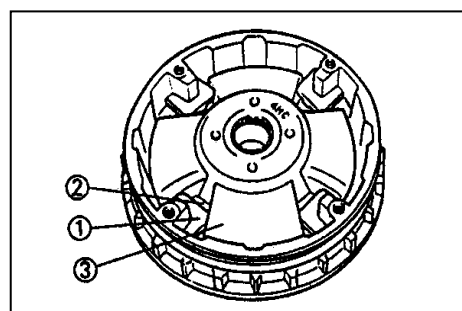
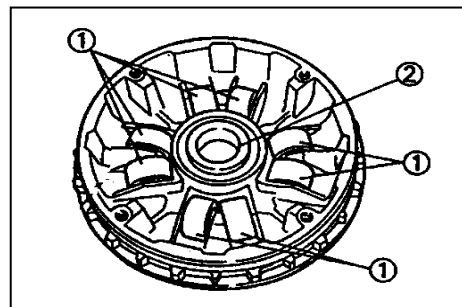

SECONDARY SHEAVE INSTALLATION

1. Apply:

- Lightweight lithium-soap base grease (to the secondary sliding sheave ① inner surface, grease nipple groove, and oil seals)
- Lightweight lithium-soap base grease (to the bearings, oil seals and inner surface of

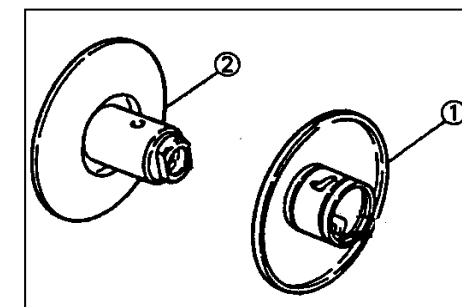

the secondary fixed sheave ②)

2. Install:

- Secondary sliding sheave ①

NOTE:

Install the secondary sliding sheave ① using the oil seal guide ② to the secondary fixed sheave ③.

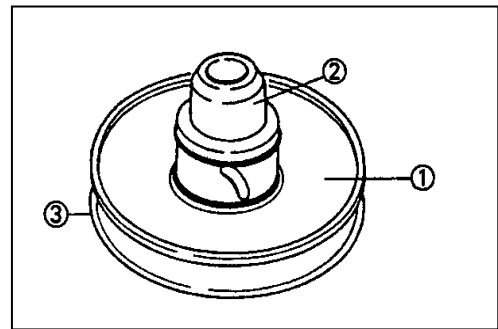

3. Install:

- Guide pin ①

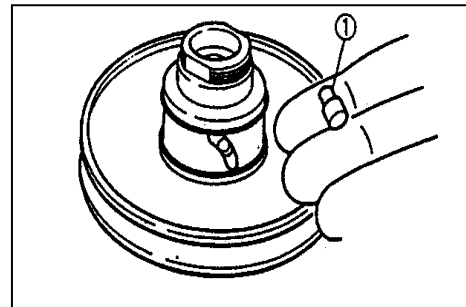

4. Apply:

- Lightweight lithium-soap base grease (to the guide pin sliding groove ①, and oil seal ② (NEW))

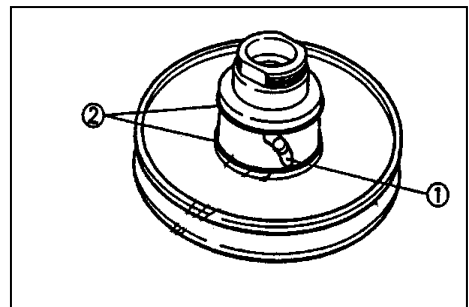

5. Install:

- Secondary sheave complete ①
- Compression spring
- Clutch carrier ②

NOTE:

Temporarily tighten the nut ⑤ while attaching the clutch spring holder ③ and clutch spring holder arm ④ and compress the spring.

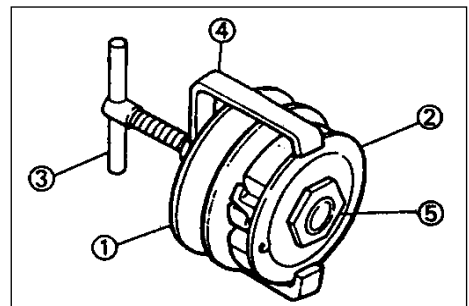

CAUTION:

Use the spacer ⑥ (30mm, thickness: 2-3mm).

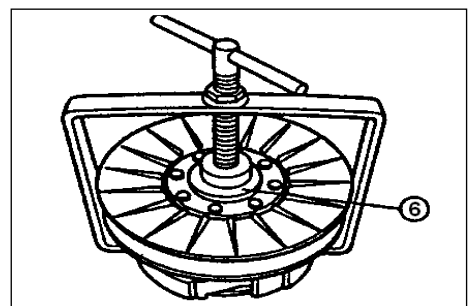

6. Install:

- V-belt ①
- Clutch assembly ②

NOTE:

Install the V-bet with clutch assembly to the primary sheave side.

CAUTION:

Never smear grease to the V-belt, secondary sheave and clutch.

7. Install:

- Nut ① (clutch carrier)

NOTE:

Tighten the nut (clutch carrier), using the locknut wrench ③ while holding the clutch carrier with the rotor holder ②.

8. Install:

- Clutch housing ①
- Nut (clutch housing) ②

NOTE:

Tighten the nut (clutch housing),using the sheave holder ③).

9. Set:

- V- belt ①

NOTE:

Move the V-belt to minimum diameter of the primary sheave ①, maximum diameter of the secondary sheave ② and make the V-belt tense.

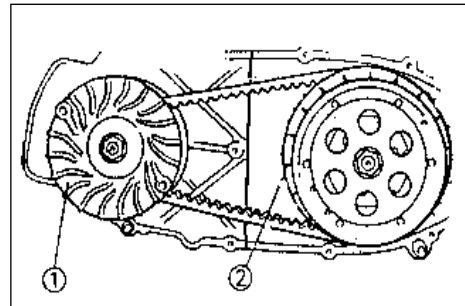
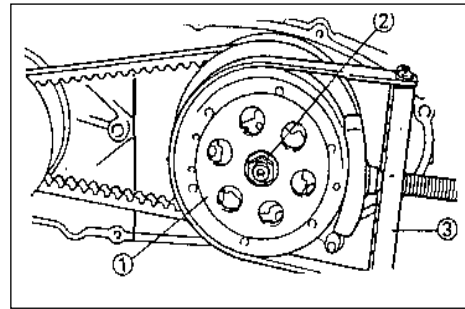
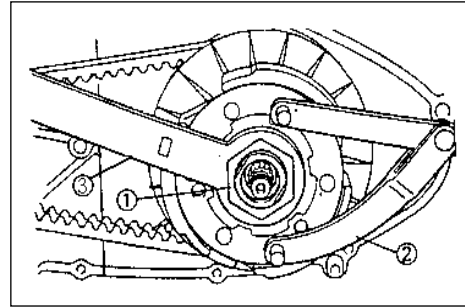
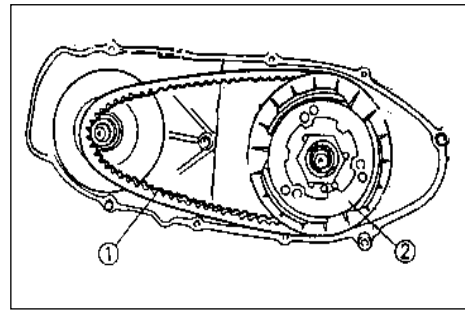

3.8A.C. MAGNETO AND STARTER CLUTCH
MAGNETO COVER AND STATOR COIL

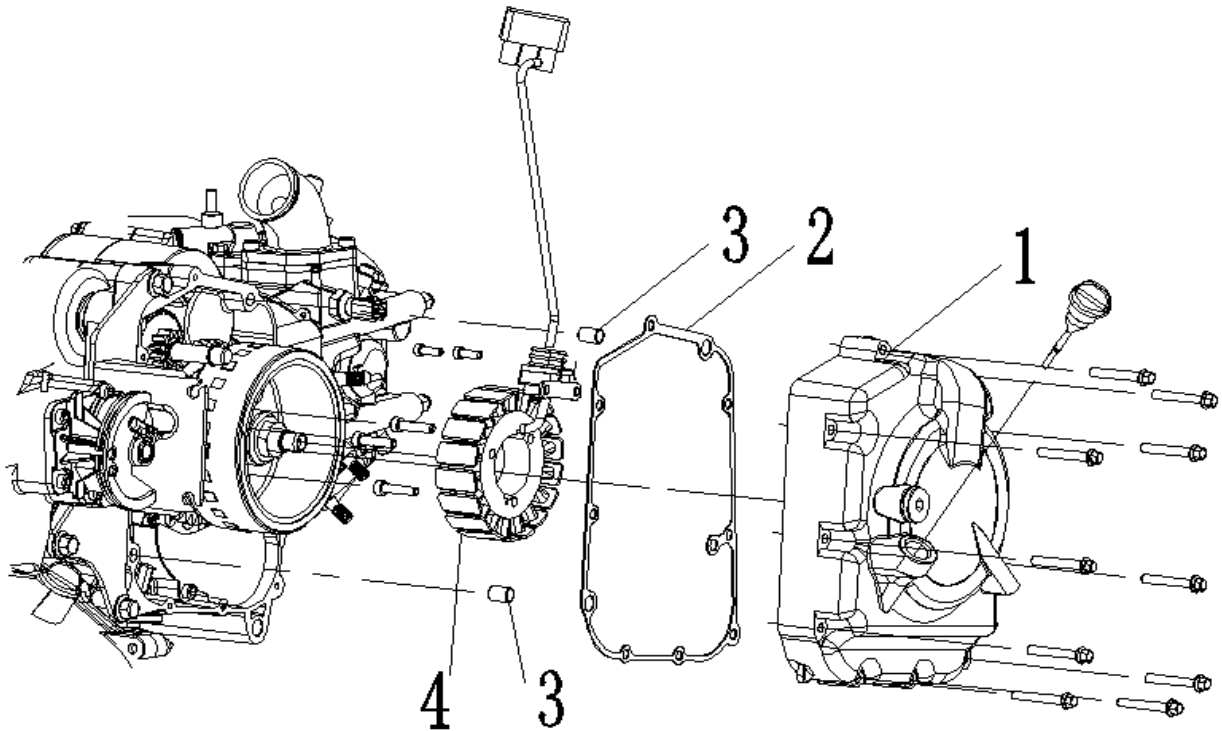

| Order | Job name/ Part name | Q'ty | Remarks |
|-------|--|------|---|
| | <p>Magneto cover and stator coil Removal Drain the engine oil.</p> | | <p>Remove the parts in order. Refer to "ENGINE OIL REPLACEMENT" section.</p> |
| 1 | Magneto cover | 2 | |
| 2 | Gasket (magneto cover) | 1 | |
| 3 | Dowel pins | 1 | Reverse the removal procedure for installation. |
| 4 | Stator coil | 1 | |

A. C. MAGNETO AND STARTER CLUTCH

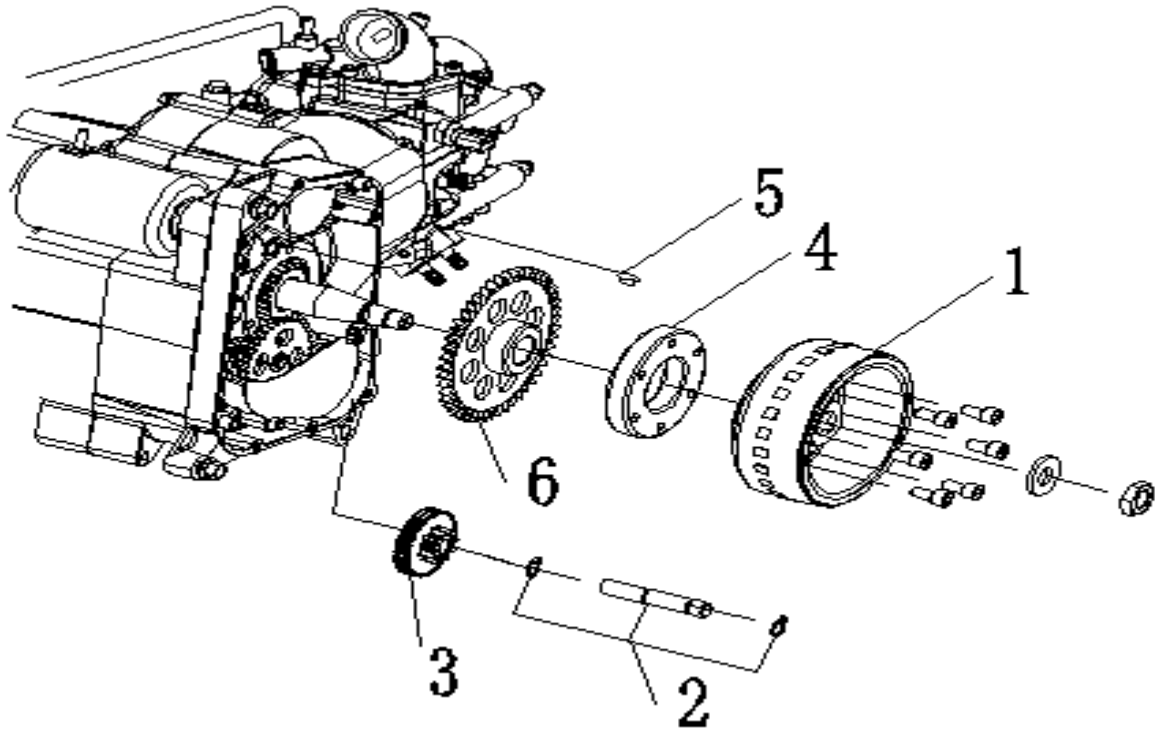

| Order | Job name/ Part name | Q'ty | Remarks |
|-------|--|------|---|
| | A.C. magneto and starter clutch Removal | | Remove the parts in order. Refer to "A.C. MAGNETO ROTOR REMOVAL /INSTALLATION" section |
| 1 | Rotor | 1 | |
| 2 | Shaft (idle gear) | 1 | Refer to "ROTOR INSTALLATION" section. |
| 3 | Idler gear | 1 | |
| 4 | Starter one way clutch assembly | 1 | Reverse the removal procedure for installation. |
| 5 | Woodruff key | 1 | |
| 6 | Starter wheel gear | 1 | |

A.C. MAGNETO ROTOR REMOVAL

1. Remove:

- Nut ① (rotor)
- Plain washer②

NOTE:

- Loosen the nut (rotor) ①while holding the rotor with a sheave holder③ .
- Do not allow sheave the holder touch to the projection on the rotor.

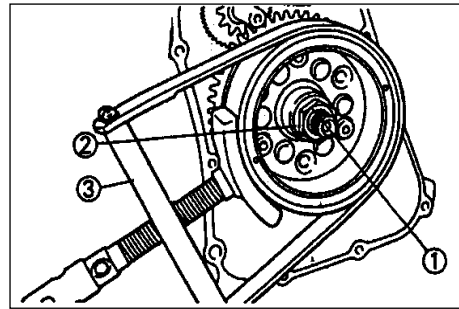

2. Remove:

- Rotor ①
- Woodruff key

NOTE:

- Remove the rotor ②using the flywheel puller.
- Center the flywheel puller over the rotor.

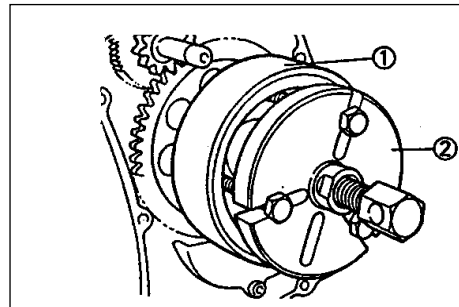

Make sure after installing the holding bolts that the clearance between the flywheel puller and the rotor is the same everywhere. If necessary, one holding bolt may be turned out slightly to adjust the flywheel puller's position.

CAUTION:

Cover the crankshaft end with the box wrench for protection.

STARTER DRIVE GEAR INSPECTION

1. Inspect:

- Starter idle gear teeth
- Starter drive gear teeth
- Starter wheel gear teeth

Burrs /chips /roughness /wear → Replace.

2. Check:

- Starter clutch operation

Push the dowel pins to the arrow direction.

Unsmooth operation → Replace.

Checking steps:

- When turning the starter wheel gear clockwise, the starter clutch and the starter wheel gear should be engaged.
- If not, the starter clutch is faulty. Replace it.
- When turning the starter wheel gear counter clockwise, it should turn freely.
- If not, the starter clutch is faulty. Replace it.

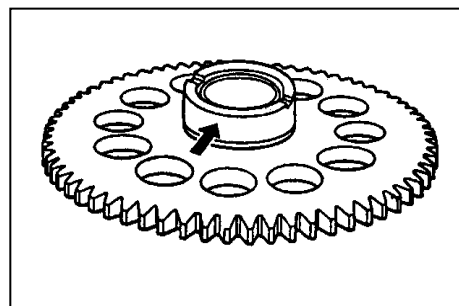
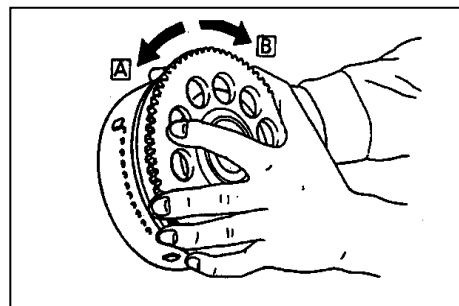

A.C. MAGNETO ROTOR INSTALLATION

1. Install:

- Starter wheel gear ①.
- Woodruff key ②

NOTE:

Install the starter wheel gear①, then install the woodruff key②.

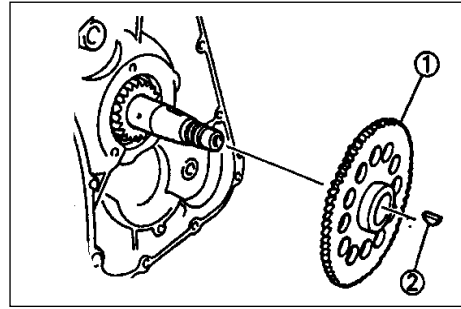

2. Install:

- Plain washer
- Rotor ①

NOTE:

- Clean the tapered portion of the crankshaft and the rotor hub.
- When installing the magneto rotor, make sure the woodruff key is properly seated in the key way of the crankshaft.

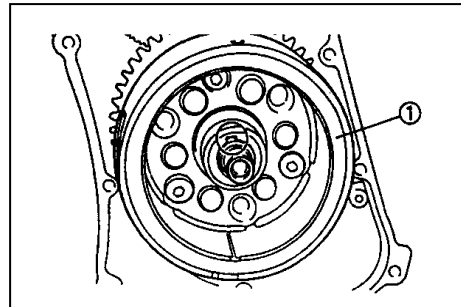

3. Tighten:

- Nut(rotor)①  80Nm(8.0m·kg)

NOTE:

Tighten the nut (rotor)① while holding the magneto rotor② with a sheave holder③.

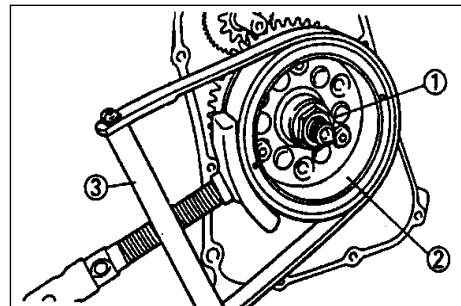

3.9 OIL PUMP

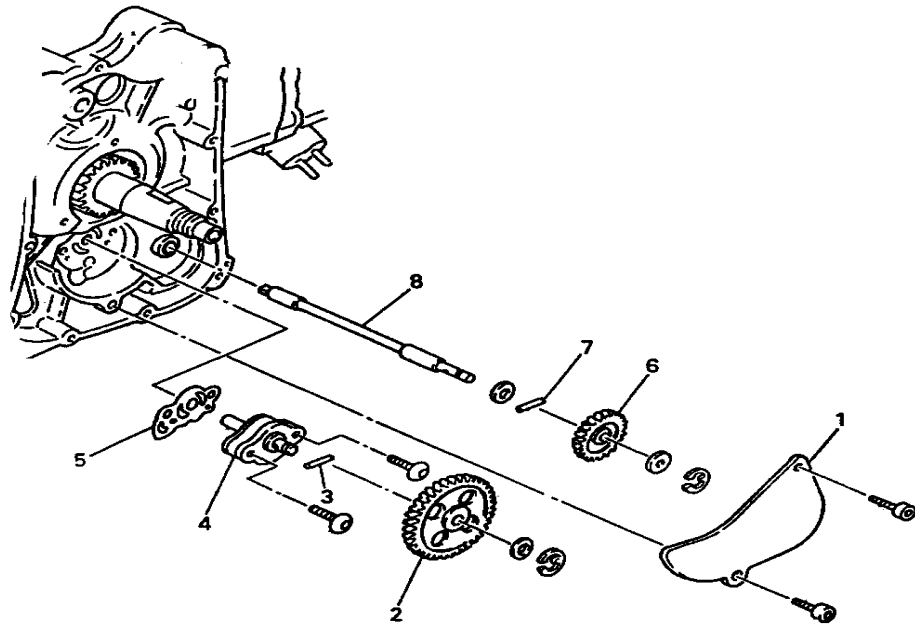

| Order | Job name/ Part name | Q'ty | Remarks |
|-------|-------------------------|------|---|
| | Oil pump removal | | Remove the parts in order. |
| | A.C. magneto | | Refer to "A.C. MAGNETO AND STARTER CLUTCH" section. |
| 1 | Cover | 1 | |
| 2 | Pump driven gear | 1 | |
| 3 | Dowel pin | 1 | |
| 4 | Oil pump assembly | 1 | |
| 5 | Gasket | 1 | |
| 6 | Impeller shaft gear | 1 | |
| 7 | Dowel Pin | 1 | |
| 8 | Shaft | 1 | |
| | | | Reverse the removal procedure for installation. |

OIL PUMP INSPECTION

1. Inspect:

- Drive gear (oil pump) ①
- Pump housing
- Pump housing cover

Wear /cracks/ damage → Replace.

2. Measure:

- Tip clearance (between the inner rotor ① and the outer rotor ②)
- Side clearance (between the outer rotor ② and the pump housing ③)
- Housing and rotor clearance (between the pump housing ③ and the rotors ① ②)

Out of specification → Replace the oil pump assembly.

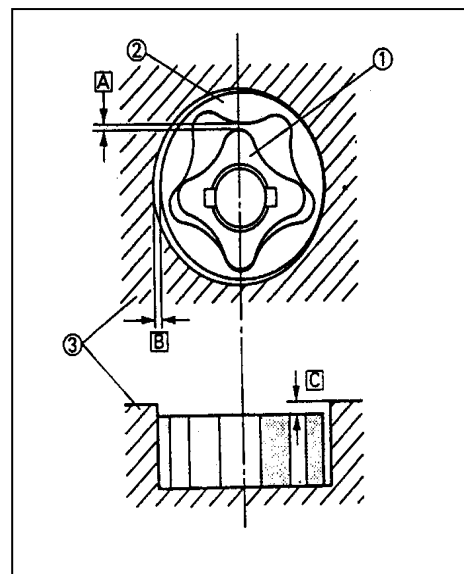
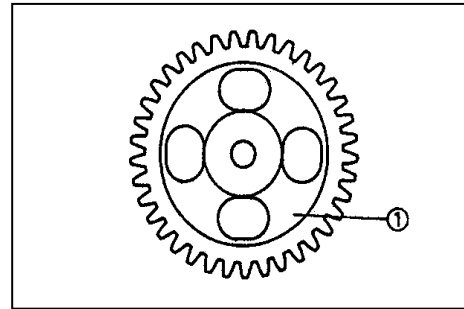

| | |
|---|---|
|  | Tip clearance A : 0.10-0.34 mm <Limit: 0.40mm> |
| | Side clearance B : 0.013-0.036mm <Limit:0.15mm> |
| | Housing and rotor clearance C : 0.04-0.09 mm <Limit: 0.15mm> |
| | |

3.10 CRANKCASE AND CRANKSHAFT

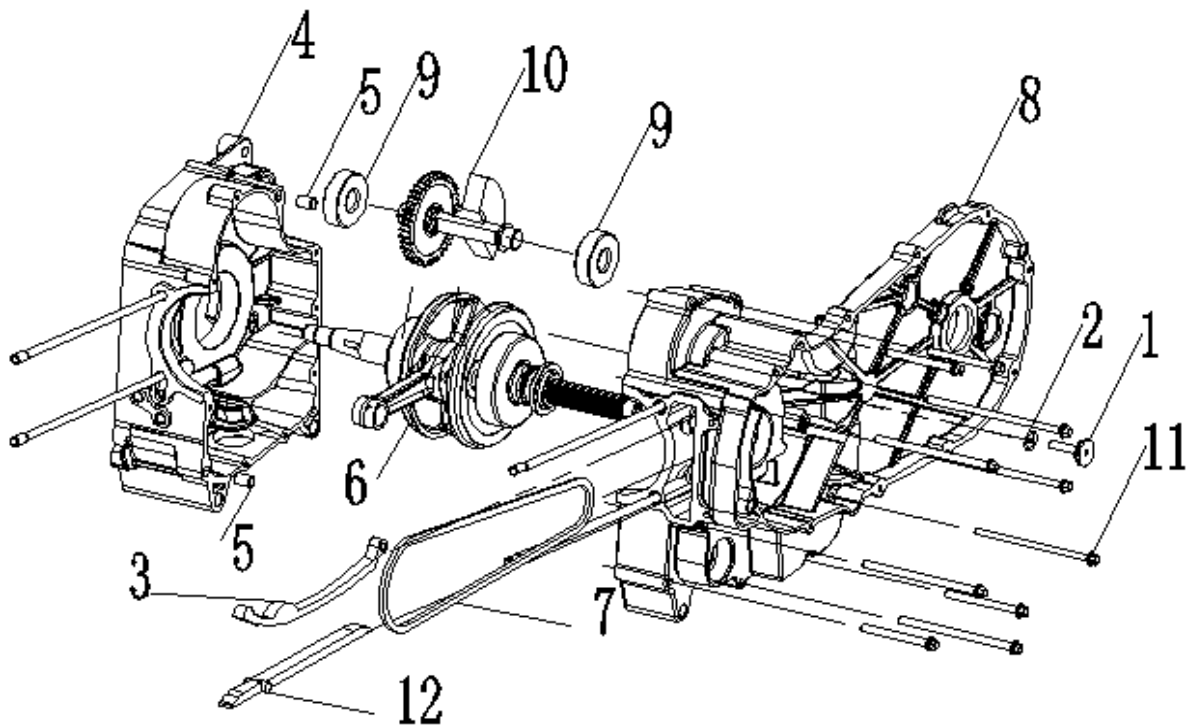

| Order | Job name/ Part name | Q'ty | Remarks |
|-------|---|------|---|
| | Crankcase and crankshaft Removal | | Remove the parts in the order. |
| | Engine removal | | Refer to "ENGINE REMOVAL" section. |
| | Cylinder head | | Refer to "CYLINDER HEAD" section. |
| | Cylinder, and piston | | Refer to "CYLINDER AND PISTON" section. |
| | V-belt, clutch, secondary/ primary Sheave | | Refer to "V BELT, CLUTCH AND SECONDARY/PRIMARY SHEAVE" section. |
| | A.C. magneto and starter clutch | | Refer to "A.C. MAGNETO AND STARTER CLUTCH" section. |
| 1 | Pull rod screw | 1 | Refer to "A.C. MAGNETO AND STARTER CLUTCH" section. |
| 2 | O-ring | 1 | Refer to "OIL PUMP" section. |
| 3 | Guide plate(on) | 1 | Refer to "WATER PUMP" section. |
| 4 | Right box | 1 | Refer to "REAR WHEEL AND REAR BRAKE" section. |
| 5 | Dowel pin | 2 | Refer to "CRANKSHAFT INSTALLATION" section. |
| 6 | Camshaft ASSY | 1 | Refer to "CRANKSHAFT REMOVAL/ INSTALLATION" section. |
| 7 | Timing chain | 1 | |
| 8 | Left box | 1 | |
| 9 | Bearing | 2 | |
| 10 | Balance shaft ASSY | 1 | |
| 11 | Bolt | 10 | Reverse the removal procedure for installation. |
| 12 | Guide plate(down) | 1 | |

CRANKSHAFT REMOVAL

1. Remove:

- Crankshaft assembly
- Timing chain

NOTE:

- Before removing the crankshaft assembly, remove the timing chain from the crankshaft sprocket.
- If the timing chain hooks to the crankshaft sprocket, the crankshaft cannot be removed.

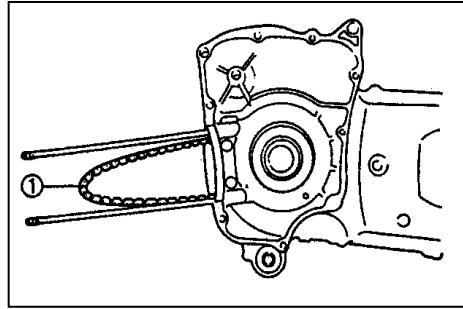

CRANKSHAFT INSPECTION

1. Measure:

- Crankshaft runout

Out of specification → Replace crankshaft and / or bearing.

NOTE:

Measure the crankshaft runout with the crankshaft assembly running slowly.

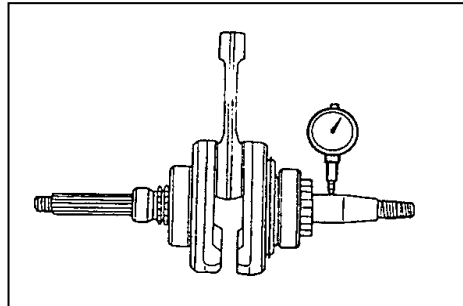

**Runout limit:
0.03 mm**

2. Measure:

- Big end side clearance

Out of specification → Replace big end bearing, crank pin and/or connecting rod.

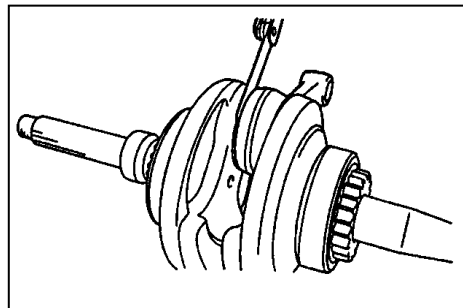

**Big end side clearance:
0.35-0.85 mm**

3. Measure:

- Crank width

Out of specification → Replace crankshaft.

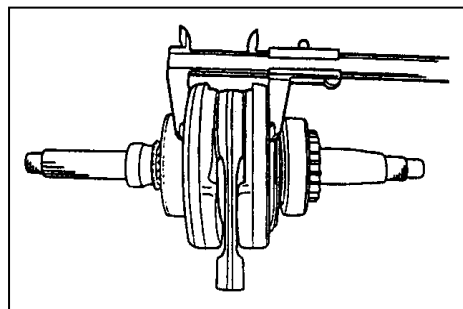

**Crank width:
59.95-60.00 mm**

4. Inspect:

- Crankshaft sprocket ①
Wear/ Damage → Replace crankshaft.
- Bearing ②
Wear/ Crack /Damage → Replace crankshaft.
- Pump drive gear ③
Wear/ Damage → Replace crankshaft.

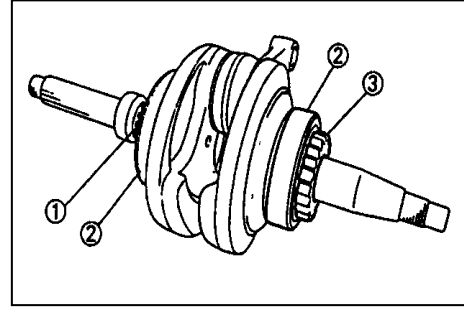

5. Inspect:

- Crankshaft journal
Clogged → Blow out the journal with compressed air.

CRANKCASE INSTALLATION

1. Clean all the gasket mating surface and crankcase mating surface thoroughly.

2. Apply:

- Sealant
(onto the crankcase mating surfaces)

NOTE:

DO NOT ALLOW any sealant to come into contact with the oil gallery.

3. Install:

- Dowel pins
- Timing chain ①

NOTE:

Install the timing chain not to be seen through the crankshaft holeⒶ on the crankcase (left)Ⓒ.

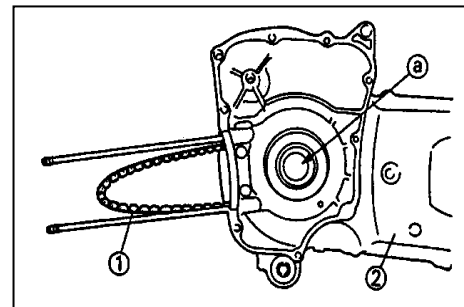
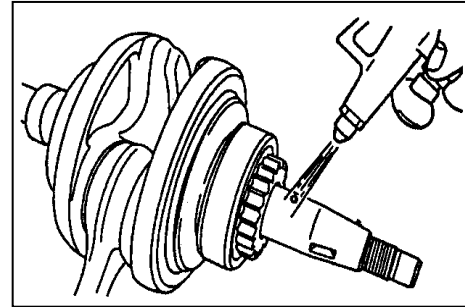

3.11 COOLING SYSTEM

3.11.1 RADIATOR

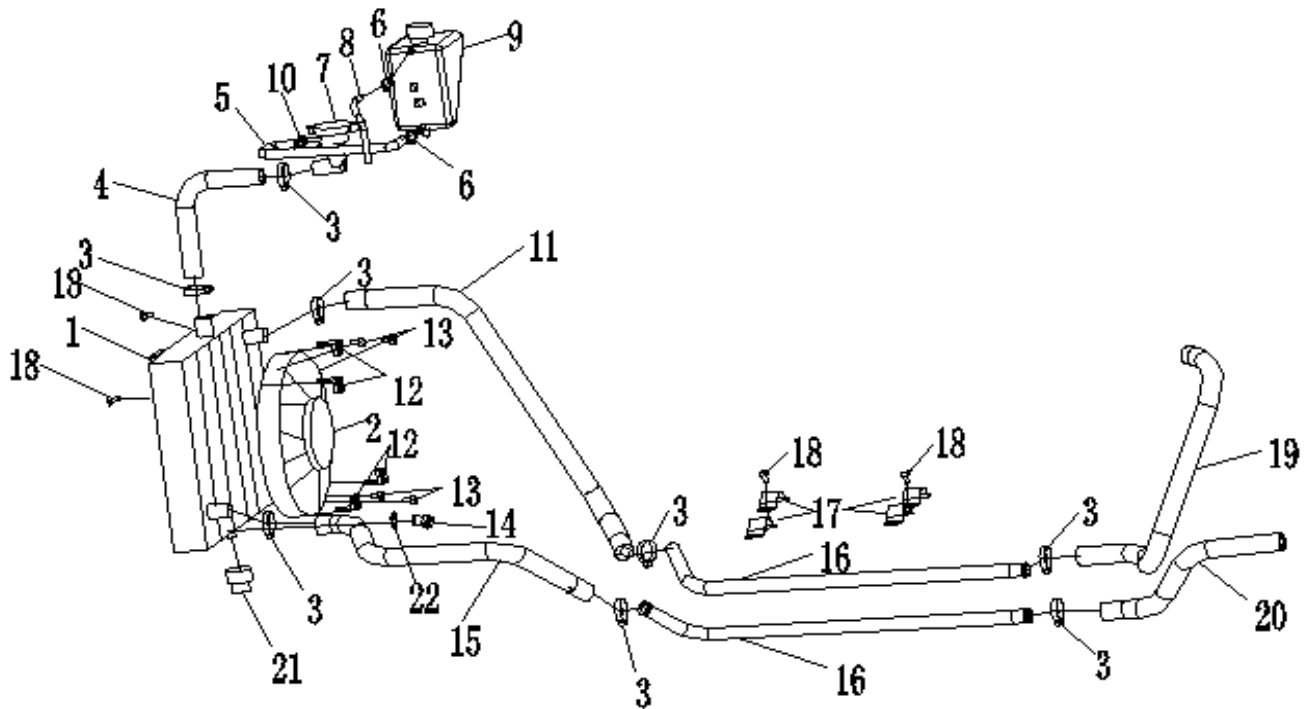

| Order | Job name/ Part name | Q'ty | Remarks |
|-------|------------------------|------|-----------------------------------|
| | Radiator removal | | Remove the parts in order |
| | Drain the coolant. | | Remove the parts in order. |
| 1 | Radiator ASSY | 1 | Refer to "COOLANT REPLACEMENT" |
| 2 | Blower ASSY | 1 | section. |
| 3 | Clamp | 8 | Reverse the removal procedure for |
| 4 | Water supply pipe | 1 | installation. |
| 5 | Return pipe | 1 | |
| 6 | Clamp 9 | 2 | |
| 7 | RADIATOR CAP | 1 | |
| 8 | Leaky pipe | 1 | |
| 9 | Leaking kettle | 1 | |
| 10 | Clamp 10 | 1 | |
| 11 | Feed hose | 1 | |
| 12 | Fan fixing card | 4 | |
| 13 | Flange Bolt | 4 | |
| 14 | THERMOSTAT SWITCH ASSY | 1 | |
| 15 | Return hose | 1 | |
| 16 | connecting pipe | 1 | |
| 17 | Water pipe fixing card | 2 | |
| 18 | Flange Bolt | 4 | |

| | | |
|----|-----------------------------------|---|
| 19 | Return hose, cylinder | 1 |
| 20 | Feed hose, valve | 1 |
| 21 | Water tank rubber cushion | 1 |
| 22 | Temperature control switch gasket | 1 |

INSPECTION

1. Inspect:

- Radiator ①

Obstruction → Blow out with compressed air through the rear of the radiator.

Flattened fins → Repair or replace.

If flattened over the 20% of radiator fin, repair or replace the radiator.

CAUTION:

Use only specified adhesive to repair the radiator.

2. Inspect:

- Radiator hoses
- Radiator pipes

Cracks/damage → Replace.

3. Measure:

- Radiator cap opening pressure
- Radiator cap opens at a pressure below the specified pressure → Replace.

| | |
|--|--|
|  | <p>Radiator cap opening pressure: 110-140kPa (1.1-1.4kg/cm² , 1.1-1.4 bar)</p> |
|--|--|

Measurement steps:

- Attach the radiator cap tester ① and adapter ② to the radiator cap ③.
- Apply the specified pressure for 10 seconds, and make sure there is no pressure drop.

4. Inspect:

- Fan motor assembly

Damage → Replace.

Malfunction → Check and repair.

Refer to "COOLING SYSTEM " section.

5. Inspect:

- Pipes

Cracks/damage → Replace.

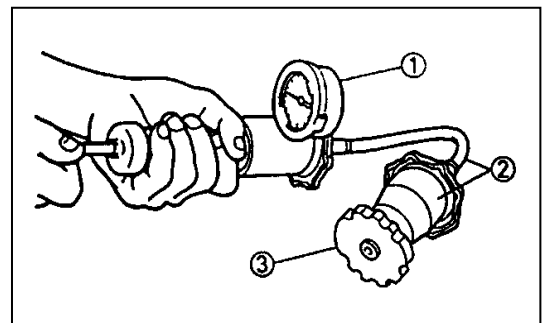
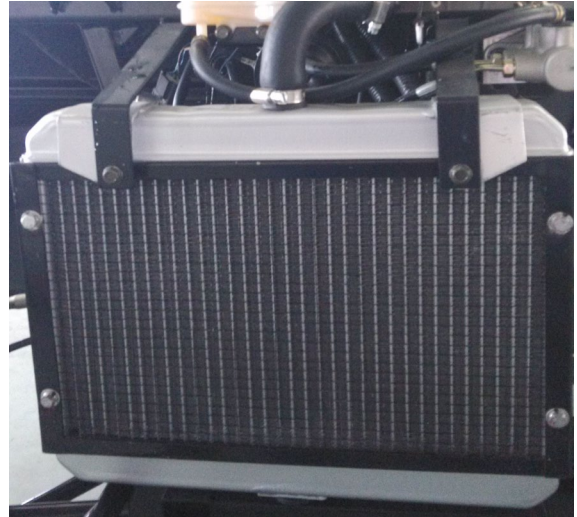

3.11.2 WATER PUMP

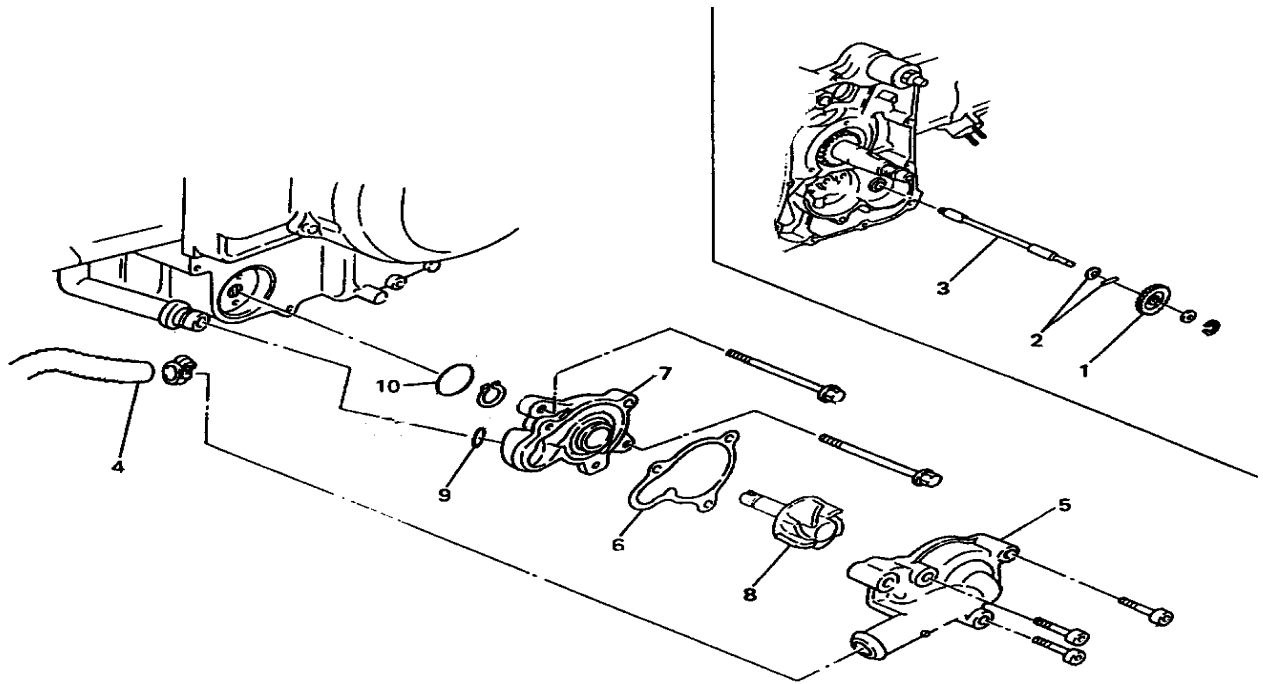

| Order | Job name/ Part name | Q'ty | Remarks |
|-------|--|------|---|
| | Water pump removal Drain the coolant. | | Remove the parts in order. Refer to "COOLANT REPLACEMENT" section. |
| | A.C. magneto | | Refer to "A.C. MAGNETO AND STARTER CLUTCH" section. |
| 1 | Impeller shaft gear | 1 | |
| 2 | Dowel pin/plain washer | 1/1 | |
| 3 | Shaft | 1 | Refer to "WATER PUMP INSTALLATION" section. |
| 4 | Outlet hose (radiator) | 1 | |
| 5 | Housing cover | 1 | |
| 6 | Housing cover gasket | 1 | Refer to "WATER PUMP INSTALLATION" section. |
| 7 | Water pump housing | 1 | |
| | Impeller shaft | 1 | Reverse the removal procedure for installation. |
| | O-ring | | |
| | O-ring | 1 | |

NOTE:

●It is not necessary to disassemble the water pump, unless there is an abnormality such as excessive change in coolant temperature and/or level, discoloration of coolant, or milky transmission oil.

●If necessary, replace water pump as an assembly.

INSPECTION

1. Inspect:

●Impeller shaft

Wear/damage → Replace.

Fur deposits → Clean.

2. Inspect:

●Impeller shaft gear

Wear/damage → Replace.

3. Inspect:

●Oil seal ①

Damage/worn/wear → Replace.

WATER PUMP INSTALLATION

1. Install:

●Oil seal ① NEW

Installation steps:

●Apply the bond to the outside of the oil seal.

●Install the oil seal by using the oil seal installer ② and middle shaft bearing driver ③

② and middle shaft bearing driver ③

2. Install:

●Oil seal ① NEW

Apply coolant to the outside of the oil seal

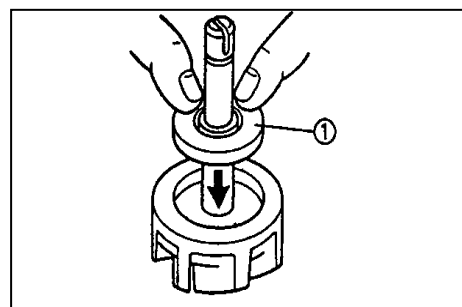
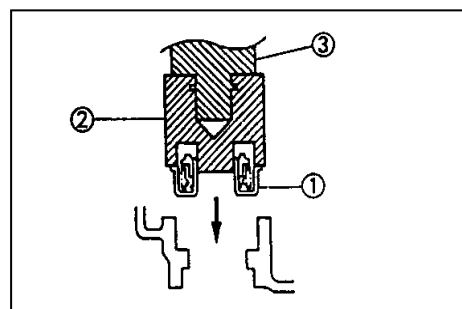
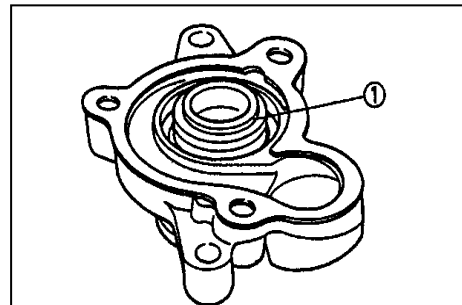
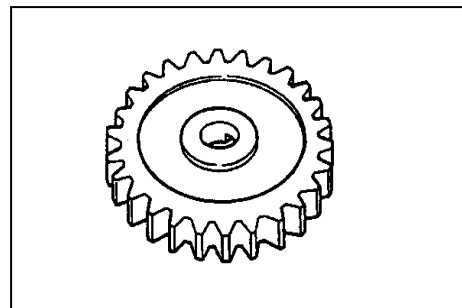
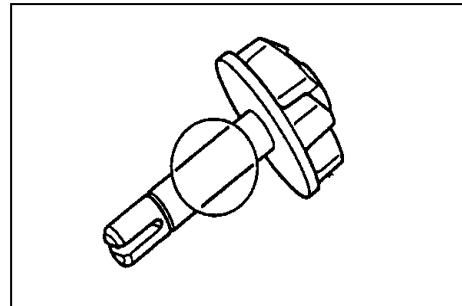

before installing.

NOTE:

Do not smear any oils or grease on the ring side of the oil seal.

3. Inspect:

- Mechanical sea , slip ring side ①
- Inspect the slip ring side of the oil seal and the impeller ② for level installation.
Incorrect level → Reinstall.

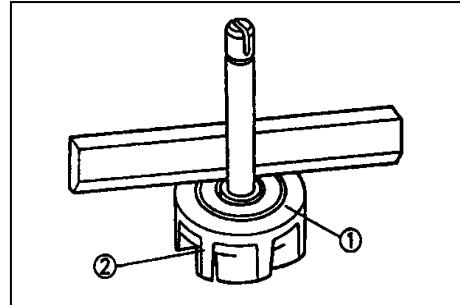

4. Install:

- Impeller shaft①
- Circ lip ② NEW

Installation steps:

- Apply a small amount of grease to the impeller shaft tip.
- Install the impeller shaft while turning it. Use care so that the oil seal is not damaged or the spring does not slip off its position.

NOTE:

After installing the impeller shaft, check it for smooth rotation.

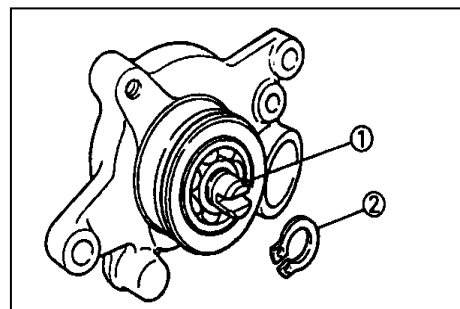

5. Install:

- O-ring①(NEW)

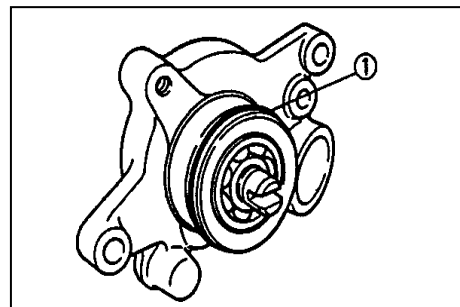

6. Install:

- Water pump housing
- Housing cover 10Nm(1.0m·kg)

7. Install:

- Shaft①
- Align the slot on the impeller shaft with the projection on the shaft when installing.

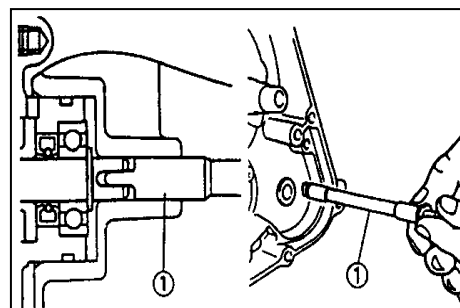

3.11.3 THERMOSTAT

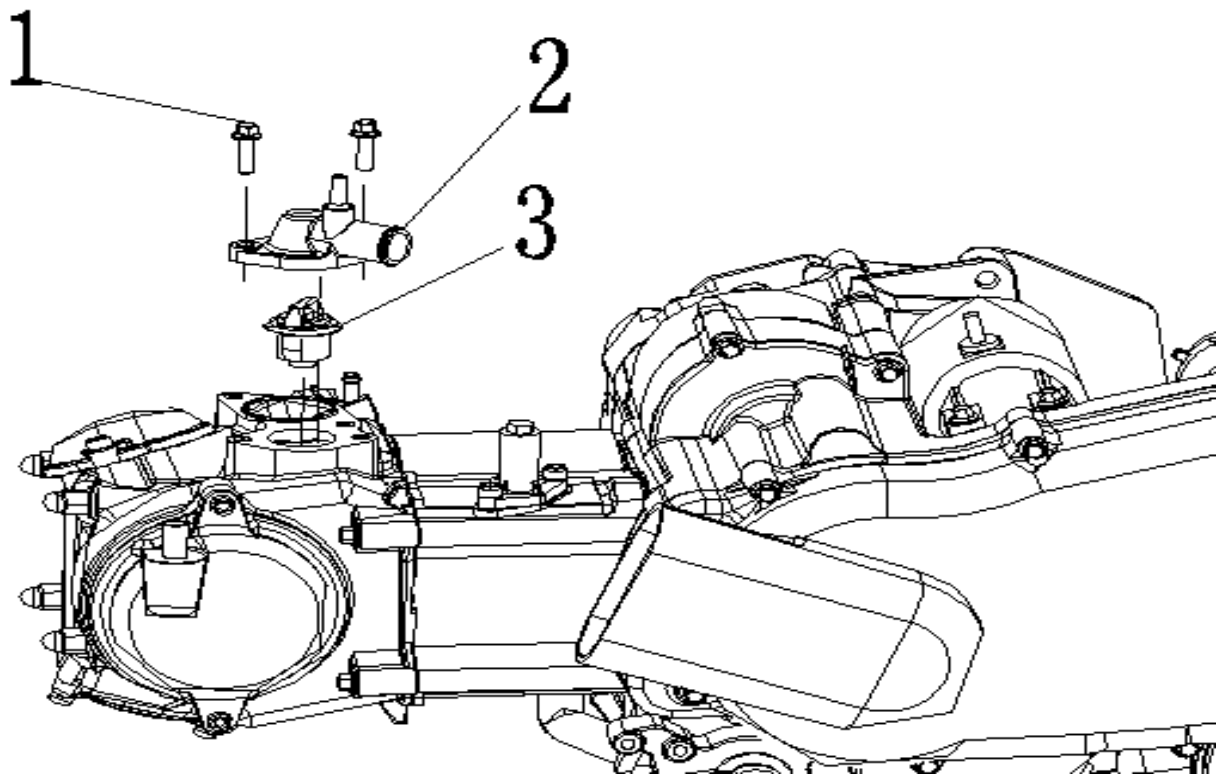

| Order | Job name/ Part name | Q'ty | Remarks |
|-------|--|------|---|
| | Thermostat removal Drain the coolant | | Remove the parts in order. Refer to "COOLANT REPLACEMENT" section. |
| 1 | Bolt | 2 | Refer to "THERMOSTAT INSTALLATION" section. |
| 2 | Thermostatic cover | 1 | |
| 3 | Thermostatic valve | 1 | Reverse the removal procedure for installation. |

INSTALLATION

1. Inspect:
- Thermostatic valve
- Valve does not open at 70-74°C → Replace.

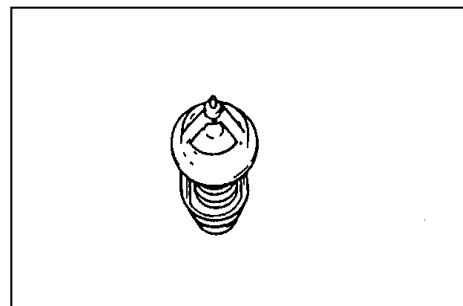

Inspection steps:

- Suspend the thermostatic valve in a vessel.
- Place a reliable thermometer in water.

● Observe the thermometer, while continually stirring the water.

- ① Thermostatic valve
- ② Vessel
- ③ Thermometer
- ④ Water

- A CLOSE
- B OPEN

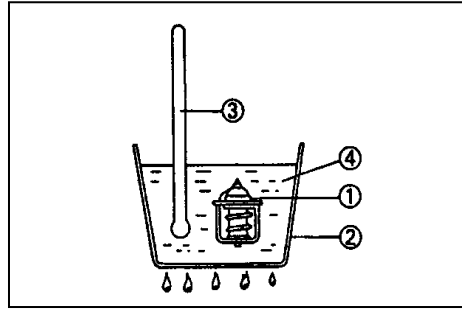

NOTE:

The thermostatic valve is sealed and its setting requires specialized work. If its accuracy is in doubt, replace. A faulty unit could cause serious over-heating or over cooling.

2. Inspect:

- Thermostatic cover
- Cracks /damage → Replace.

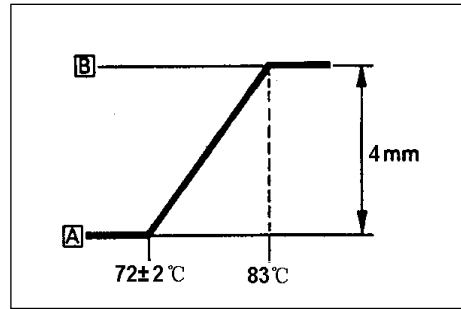

INSTALLATION

1. Install:

- Thermostatic valve
- Thermostatic cover

3.12 Transmission assembly (Independent)

Failure analysis and repair of the transmission assembly refer to the table:

| Fault type | | Possible causes of failure | Measures | Maintenance Reference |
|---|---------------------------------|--|---|---------------------------------------|
| leakage | Shift shaft leakage | O-ring damage | replace | Remove the gearshift mechanism |
| | V-belt with slip | Spindle oil seal is damaged | replace | Remove the left cover of the gearbox |
| | Front output shaft leakage | The front output shaft oil seal is damaged | replace | Remove the front cover of the gearbox |
| | | The front output shaft is damaged | replace | Remove the front output shaft |
| | Rear output shaft leakage | The rear output shaft oil seal is damaged | replace | Removal |
| | | The rear output shaft is damaged | replace | Remove the rear output shaft assembly |
| gear unclear | The shifter fork is damaged | replace | Remove the gear control | |
| | The shifting cam is damaged | replace | | |
| | The shift stop lever is damaged | replace | | |
| | Damage of shift drum | replace | Refer to "Removing the main shaft and auxiliary shaft assemblies" | |
| Difficulty in shifting or unable to shift gears | The shifter fork is damaged | replace | | |
| | Shift drum wear / damage | replace | | |
| | The shift disc is damaged | replace | | |
| | The shift shaft is damaged | replace | | |
| | Defective shift cable | replace | Refer to the vehicle section to replace the shift cable | |

3.12.1 The transmission is connected to the engine

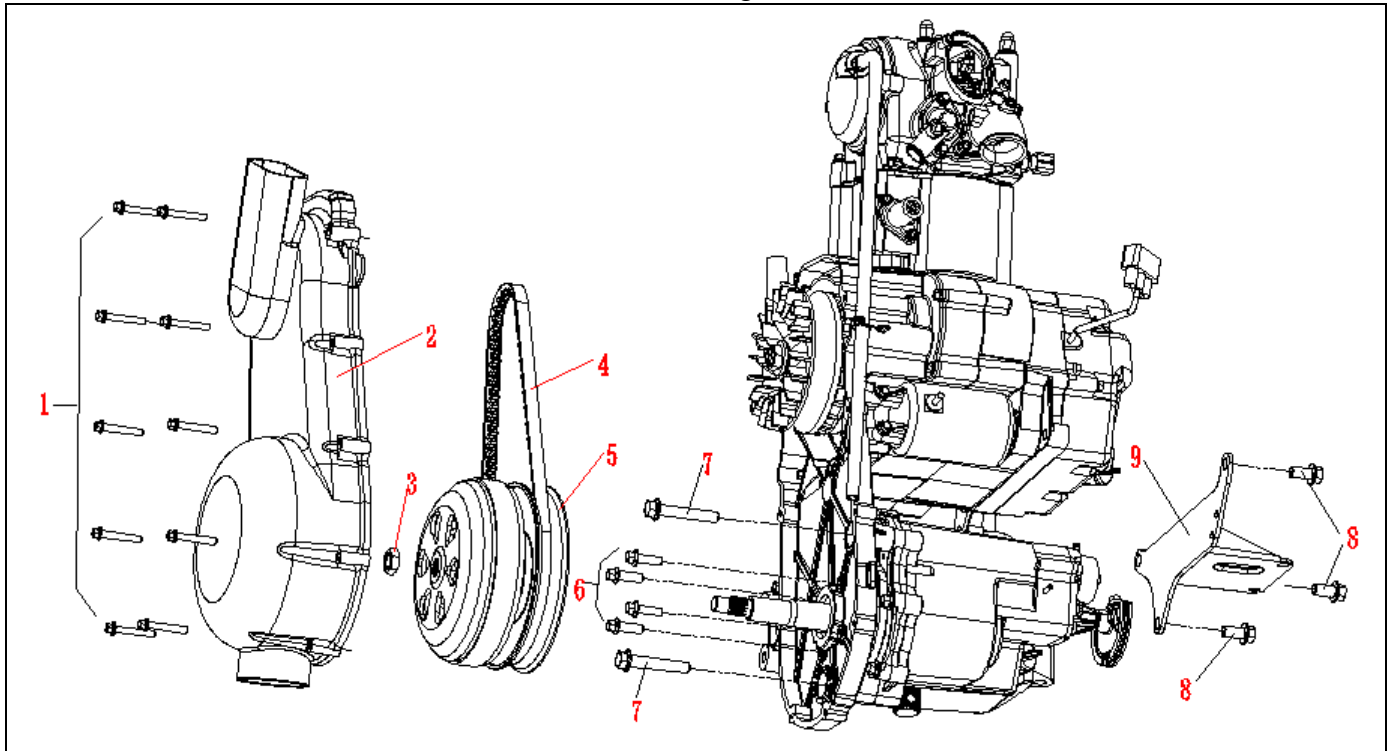

| order | Process Name / Part Name | Quantity | Remarks |
|-------|--|----------|---|
| | Remove the transmission assembly | | Refer to "V type belt, clutch and driven / active pulley" |
| | Remove the transmission assembly from the engine | | |
| 1 | Bolt M6X40 | 10 | |
| 2 | Left cover | 1 | |
| 3 | Nut M14X1 | 1 | |
| 4 | Follower clutch assembly | 1 | |
| 5 | Drive belt | 1 | |
| 6 | Bolt M8 | 4 | |
| 7 | Bolt M10 | 2 | |
| 8 | Bolt M10 | 3 | |
| 9 | Connection plate | 1 | |

Examination

1、leakage

- Shift Shaft (O-ring)
- Shift drum (O-ring, at the inside of transfer indicator)
- Transmission left cover
- Transmission (rear output shaft oil seal)
- Transmission front cover (front output shaft oil seal)

3.12.2 Shifting mechanism

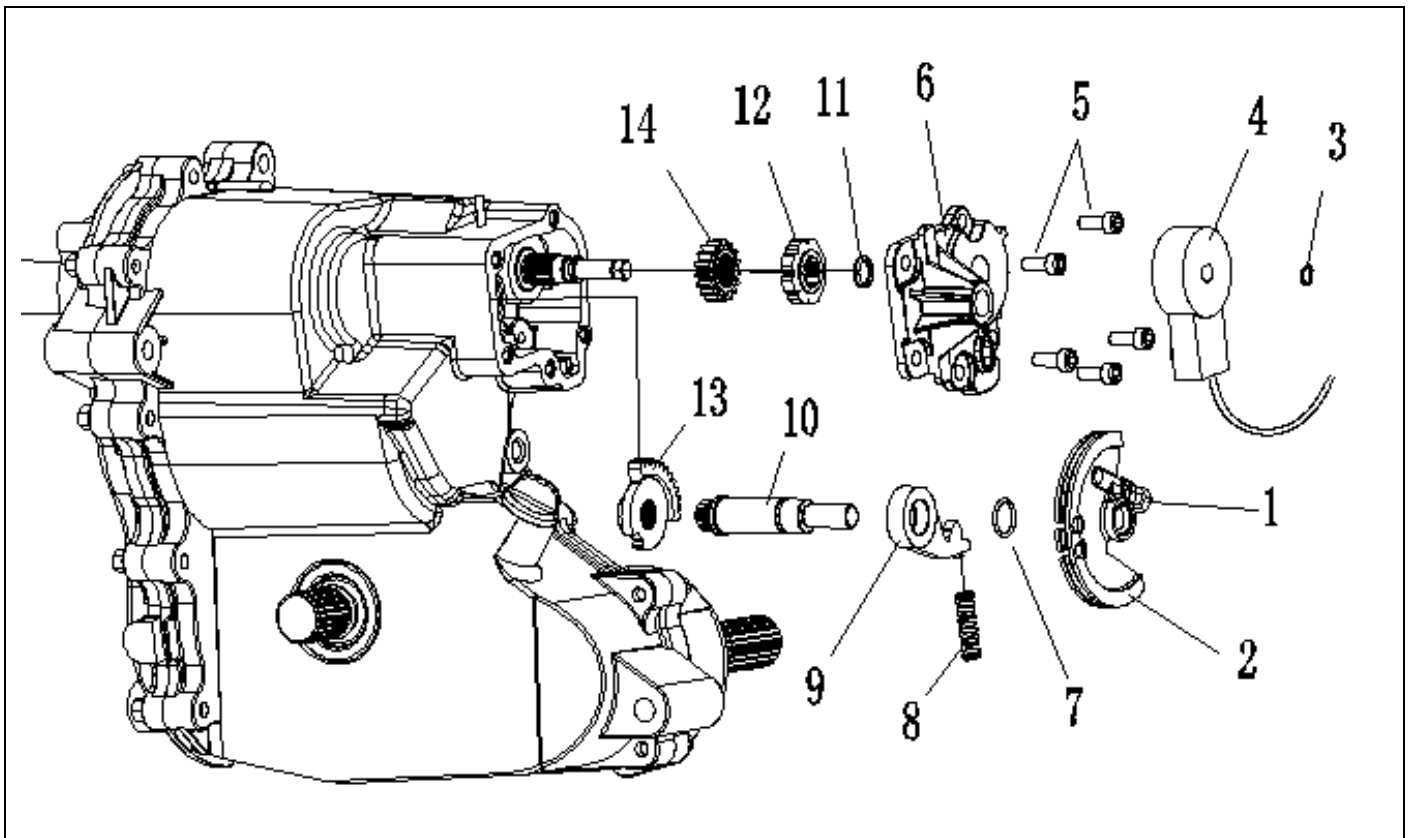

| order | Process Name / Part Name | Quantity | Remarks |
|-------|------------------------------------|----------|----------------|
| | Remove the shifting mechanism | | When necessary |
| | Remove the gearbox from the engine | | |
| 1 | Loosen the M6 bolts | 1 | |
| 2 | Shift cable tray | 1 | |
| 3 | Shaft Collar | 1 | |
| 4 | Shift switch | 1 | |
| 5 | Bolt M6 | 5 | |
| 6 | Shift small cover | 1 | |
| 7 | O-ring | 1 | |
| 8 | Shift positioning spring | 1 | |
| 9 | Shift stop lever | 1 | |
| 10 | Shift shaft | 1 | |
| 11 | O-ring | 1 | |
| 12 | Shift cam | 1 | |
| 13 | Shift drive gear | 1 | |
| 14 | Shift driven gear | 1 | |

1、 Inspect

- The spline of the shift cable tray
Wear / damage → replacement.
- Shaft collar 9 → Replace with new one.
- Shift positioning spring
Fail / Out of Standard → Replace.

| | |
|---|------------------------|
|  | Limit height: 28 mm |
|---|------------------------|

- Shift stop lever
Wear / Out of Standard → Replace.

| | |
|---|---|
|  | Standard value h: 15 ± 0.5mm Limit value: 14mm |
|---|---|

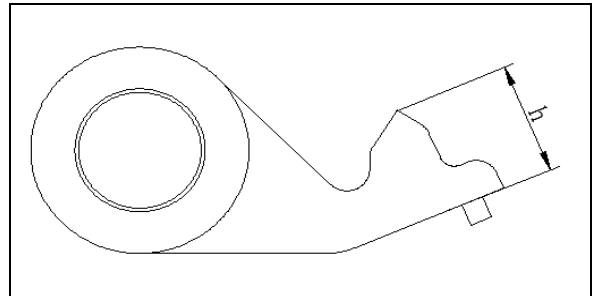

- Spline of the shift shaft
Wear / damage → replacement
- Shift drive gear
Wear / damage → replacement
- Shift cam
Wear / damage → replacement
- Shift driven gear
Wear / damage → replacement

2、 Installation

●Shift drive gear

Note:

The side of the shift driven gear with the marked side facing up.

●Shift driven gear

Note:

The gears of the shift driving gear and the shifting driven gear are in a one-to-one correspondence, and when the shift driving gear is mounted, it is ensured that the shift driven gear has a marked one tooth meshed

- Shift shaft
- Shift cam
- Shift stop lever
- Shift positioning spring
- O-ring 13.8X1.8 (shift shaft)
- O-ring 9X1.8 (shift drum)

with the two gear teeth marked by the shifting driving gear . Otherwise, it will cause the shift is not accurate, must be re-adjusted. When the teeth, you can turn the shift drum to ensure that the mark is aligned.

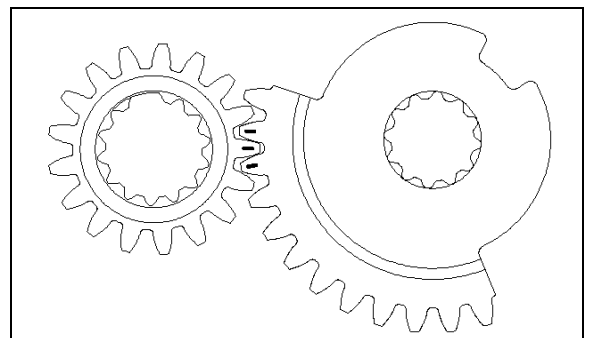

Note:

Apply a small amount of grease to the

O-ring to prevent the O-ring from being cut when installing the small shift cover.

- Shift small cover

Sealant (applied to the transmission cover surface)

Note:

Do not apply too much sealant on the bonding surface to prevent excessive of the sealant into the gearbox interior, blocking the oil path and airway.

Do not apply the sealant to the threaded hole to prevent plugging of the threaded hole.

- Bolt M6

Use a rag to wipe out at the junction of excess sealant.

3.12.3 A spindle assembly and a countershaft assembly

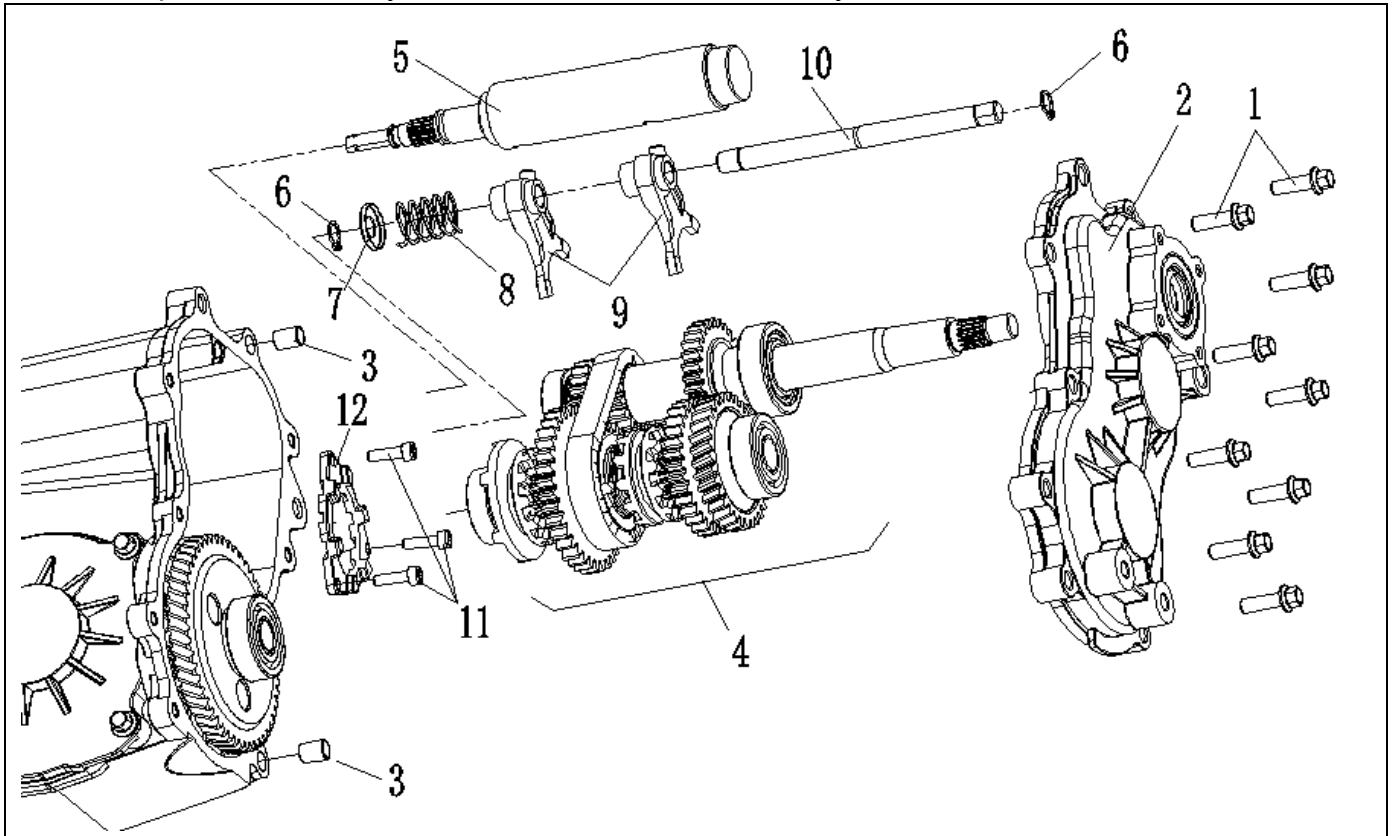

| order | Process Name / Part Name | Quantity | Remarks |
|-------|--|----------|---|
| | Remove the spindle assembly and the countershaft assembly Remove the gearbox assembly Drain the oil (remove drain screw and gasket) Remove the gearshift mechanism Bolt M8 Left cover of transmission | | Refer to "Disconnecting the Transmission from the Engine" Refer to "Removing the Shift Mechanism" The whole removed If necessary, decomposition If there is |
| 1 | Locating Pins | 9 | If there is |
| 2 | Spindle assembly, vice shaft assembly, shift drum and fork, fork shaft | 1 | If there is |
| 3 | Shift drum | 2 | |
| 4 | Shifter fork assembly Shaft Collar Fork spring cover | | |
| 5 | Low-speed fork spring | 1 | |

| | | | |
|----|--------------|---|--|
| | Fork | | |
| 6 | Fork shaft | 2 | |
| 7 | Bolt M6 | 1 | |
| 8 | Parking seat | 1 | |
| 9 | | 2 | |
| 10 | | 1 | |
| 11 | | 3 | |
| 12 | | 1 | |

1、 Examination

●Oil seal

Damage / wear / failure of inner spring → Replacement.

●Shift drum

Spline damage / wear → Replacement.

Drum 2 groove width

Substandard → replacement.

| | |
|---|---|
|  | Standard values: 8.0-8.2mm Limit value: 8.75mm (except low gear) |
|---|---|

●Shifter fork

Damage / wear → replacement.

Shifter fork substandard →

| | | |
|--|----------------------------------|---|
| | Symmetry with respect to the pin | Standard value: 0.1mm Limit value: 0.175mm |
|--|----------------------------------|---|

replacement.

| | | |
|---|-----------|--|
|  | thickness | Standard value: 4.9-5.1mm Limit value: 4.75mm |
|---|-----------|--|

Note:

Check, if found fork burns, discoloration, please check whether the corresponding shift plate burns, discoloration or damage. If so, please also replace.

To remove the shift disc, refer to "Disassembling the Main and Secondary Shaft Assemblies".

●Low-speed fork spring

Failure → replacement

●Shifter fork shaft

Wear / damage / substandard → replacement

| | | |
|---|-------------------------|---------------|
|  | Diameter standard value | 11.66—11.84mm |
|---|-------------------------|---------------|

| | |
|----------------------|---------|
| Diameter limit value | 11.41mm |
|----------------------|---------|

2. Installation

- Parking gear
- Bolt M6
- Shifter fork and shifter fork shaft assembly
Disassembly shifter fork and shifter fork shaft
⑤ components
Install shaft collar 12 ①
Install the shifter fork spring cover ②
Install low-speed shifter fork spring ③
2 shifter forks installed ④ (with pin a side up)
Shifter forks were installed on the vice shaft on the shift

disc

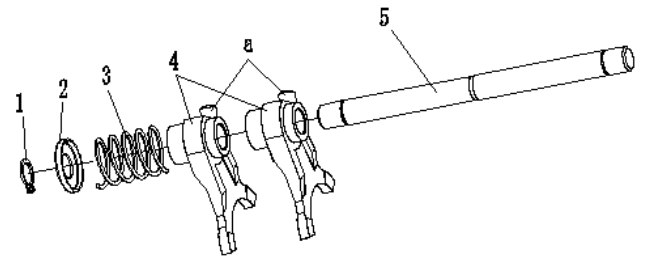

- Shift drum

Note:

The pin a of the shifter fork is attached to the guide groove of the shift drum,
The small end of the shift drum faces toward the spring.

- The overall installation of the main and vice-axis components and fork components, shift drum
- Locating Pins

●Sealant (applied to the transmission cover surface)

Note:

Do not apply too much sealant on the bonding surface to prevent excessive of the sealant into the gearbox interior, blocking the oil path and airway.
Do not apply the sealant to the threaded hole to prevent plugging of the threaded hole.

- Bolt M8

Use a cloth to wipe away any excess sealant from the bond surface.

3. The main and auxiliary shaft components are disassembled

1601

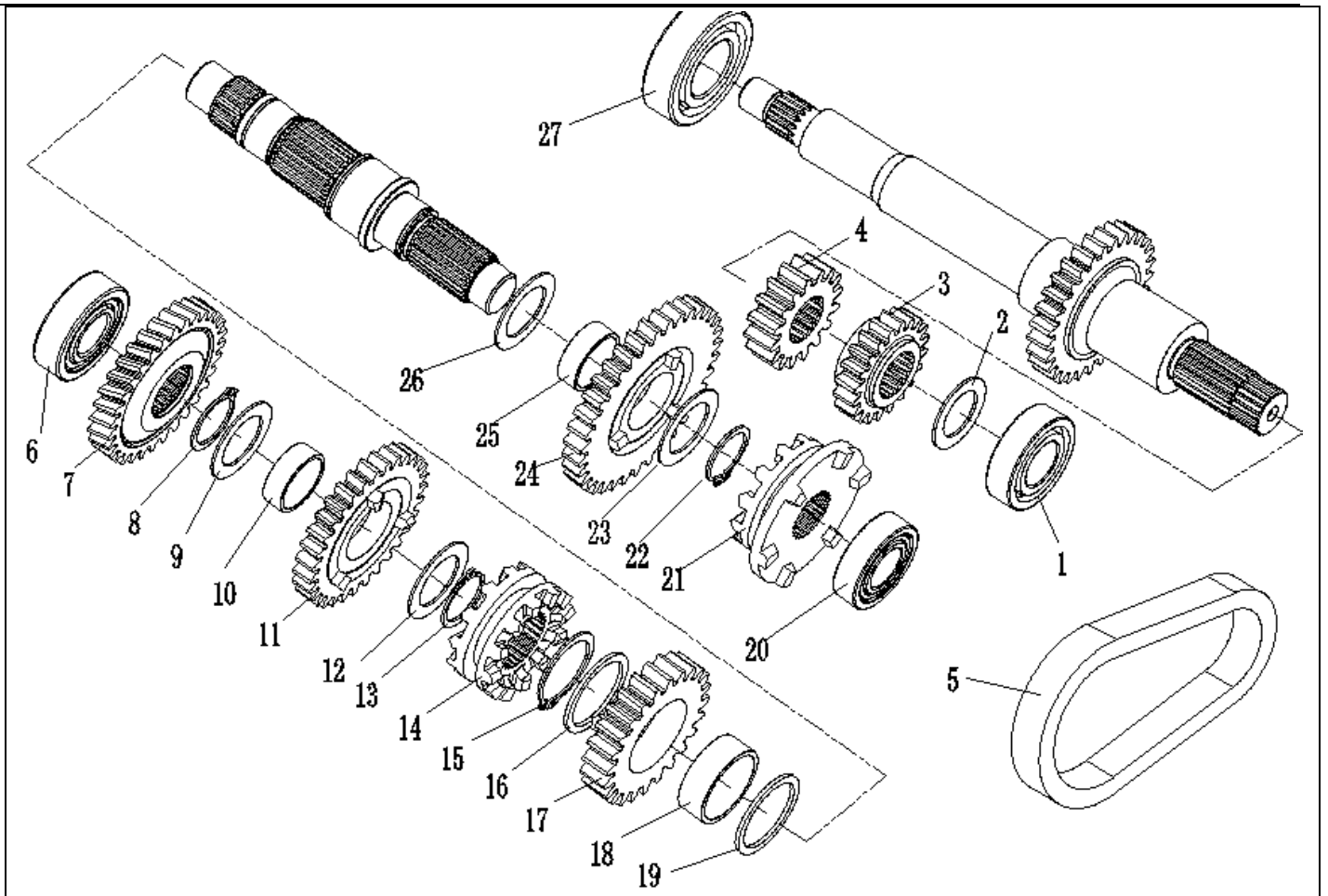

| order | Process Name / Part Name | Quantity | Remarks |
|-------|------------------------------------|----------|---------|
| 1 | Bearing 6004 | 1 | |
| 2 | Washer 21X30X2 | 1 | |
| 3 | Low speed driving gear | 1 | |
| 4 | Drive sprocket | 1 | |
| 5 | Toothed chain | 1 | |
| 6 | Bearing 6204 | 1 | |
| 7 | Transition gear 1 | 1 | |
| 8 | Shaft Collar 25 | 1 | |
| 9 | Washer 25X38X1.2 | 1 | |
| 10 | Needle roller bearings 25X29X10 | 1 | |
| 11 | High speed driven gear | 1 | |
| 12 | Washer 25X38X1.2 | 1 | |
| 13 | Shaft Collar 25 | 1 | |
| 14 | Reverse high speed shift | 1 | |
| 15 | Shaft Collar 32 | 1 | |
| 16 | Washer 32X39.2X1.8 | 1 | |
| 17 | Driven sprocket (reverse gear) | 1 | |
| 18 | Needle Roller Bearings 32X37X13 | 1 | |

| | | | |
|----|------------------------------------|---|--|
| 19 | Washer 32X39.2X1.8 Bearing 6004 | 1 | |
| 20 | Low-speed parking shift | 1 | |
| 21 | Shaft Collar 25 | 1 | |
| 22 | Washer 25X38X1.2 | 1 | |
| 23 | Low speed driven gear | 1 | |
| 24 | Needle roller bearings | 1 | |
| 25 | 25X29X10 Washer 25X38X1.2 | 1 | |
| 26 | Bearing 6205 | 1 | |
| 27 | | 1 | |

Examination

●Reverse high speed shift

Worn / damaged / broken → replaced

●Low-speed parking shift

Worn / damaged / broken → replaced

●Reverse high speed gear

Worn / damaged / broken → replaced

●Low speed parking gear

Worn / damaged / broken → replaced

●Spindle

Thread damage / teeth → replacement

Gear wear / damage / fracture → replacement

●Shaft Collars

Deformation / distortion / damage → replacement

Assembly:

Refer to "Decomposition of Main and Secondary Shaft Components".in reverse order of decomposition.

3.12.4Output shaft assembly

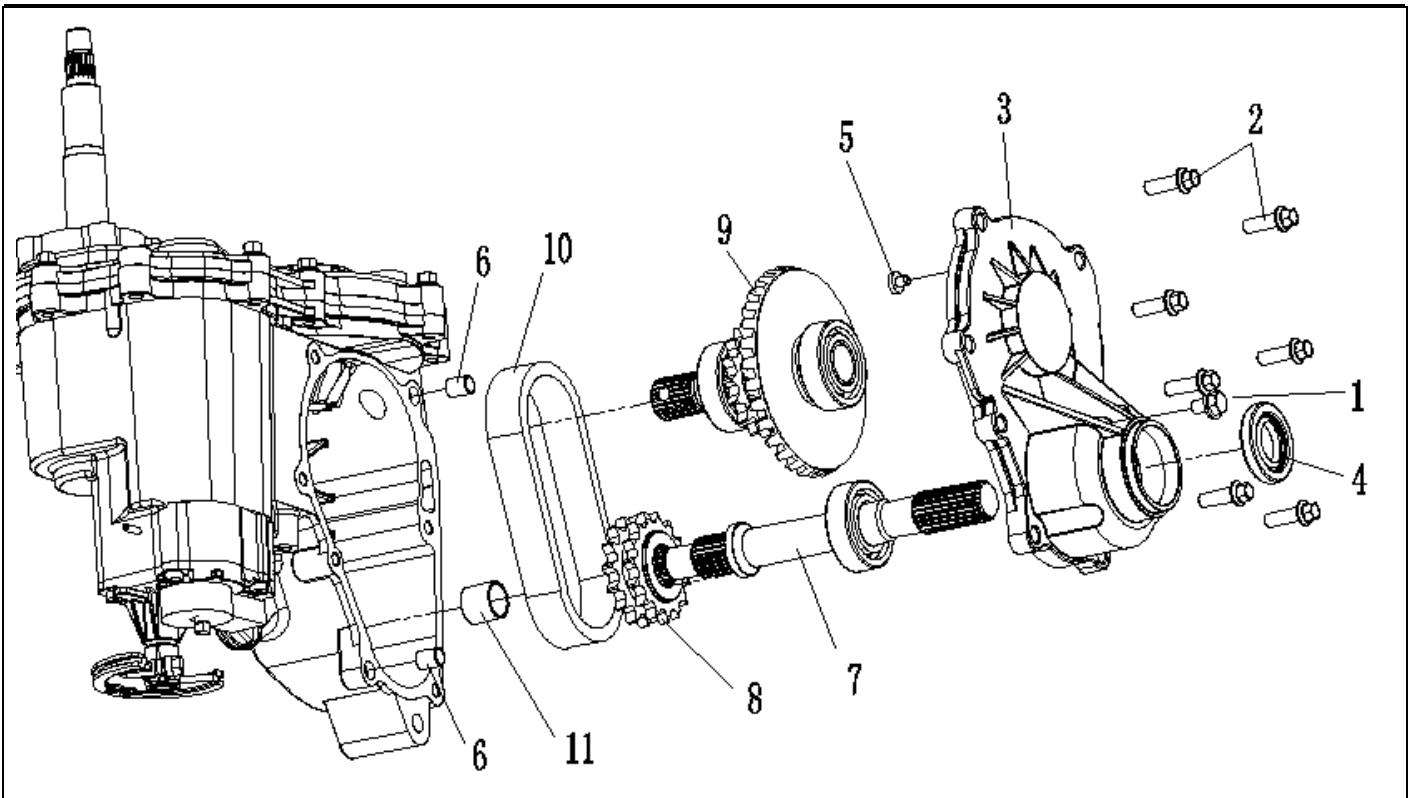

| order | Process Name / Part Name | Quantity | Remarks |
|-------|---|----------|---|
| 1 | Remove the output shaft assembly Remove the gearbox assembly | | Refer to "Disconnecting the Transmission from the Engine" |
| 2 | Drain the oil (remove drain screw and gasket) | 1/1 | when necessary when necessary |
| 3 | Bolt M8 | 7 | |
| 4 | Transmission front cover | 1 | |
| 5 | Oil seal | 1 | when necessary |
| 6 | Limit pin | 2 | |
| 7 | Locating Pins | 1 | |
| 8 | Front output shaft assembly Rear output shaft assembly | 1 | |
| 9 | Transmission chain Remove the shaft sleeve | 1 | |
| 10 | | 1 | |
| 11 | | 1 | |

Examination

- Oil seal

Damage / wear / failure of inner spring → Replacement.

- Front output shaft

Spline damage / distortion / break / crack → replacement

●Bearings

Wear / Gap / Crack → Replace

●Rear output shaft

Spline damage / distortion / break / crack → replacement

●Bearings

Wear / Gap / Crack → Replace

●Large bevel gear

Tooth surface damage / distortion / fracture / crack → replacement

Note:

If you replace the output shaft, while complete sets of replacement, with the assembly of large bevel gear, drive sprocket, both ends of the bearing and paired with small bevel teeth.

●Chain

Damage / distortion / fracture / crack / elongation → **replacement**

| | |
|---|--------------------|
|  | h Standard value: |
| | 0.2-0.96mm |
| | Limit value: 2.9mm |

Note: When measuring, measure the chain by pressing forward.

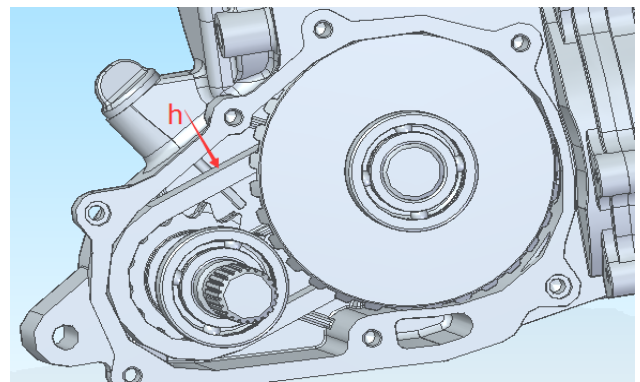

●Shaft sleeve

Damage / wear → replacement.

| | |
|---|------------------|
|  | standard value: |
| | 19-19.021mm |
| | limits: 19.039mm |

Note:

When removing damaged bushings, be careful not to damage the bores.

Assembly:

Refer to disassembly in reverse order.

- Shaft sleeve

In the sleeve hole is coated with a little grease.

- Rear output shaft assembly and chain

Apply a small amount of grease to the lip of the oil seal.

- Driven sprocket

- Output shaft assembly

- Locating Pins

- Apply a small amount of sealant to the lid

- Transmission front cover

Note:

Install the stop pin on the front cover of the gearbox. Before installing the limit pin, apply a small amount of grease to the stop pin hole on the front cover of the gearbox to prevent dropping during assembly. If you fall into the gearbox, but not found in time, the gearbox is very dangerous, there may be serious accidents.

- Bolt M8

- Drain bolts and gaskets

NOTES

CHAPTER 4 CHASSIS

WARNING

The parts of different types/ variants/ versions maybe un-interchangeable, even some parts have almost same appearance. Always refer to Parts Manual of each CUV model for spare parts information and service.

4.1 FRONT A-ARM REPLACEMENT

4.2 REAR A-ARM REPLACEMENT

4.3 REAR STABILIZER BAR REMOVAL/INSTALLATION

4.4 FRONT STRUT REPLACEMENT

4.5 FRONT STRUT BALL JOINT REPLACEMENT

4.6 BOX REMOVAL/INSTALLATION

4.7 STEERING ASSEMBLY REMOVAL/INSTALLATION

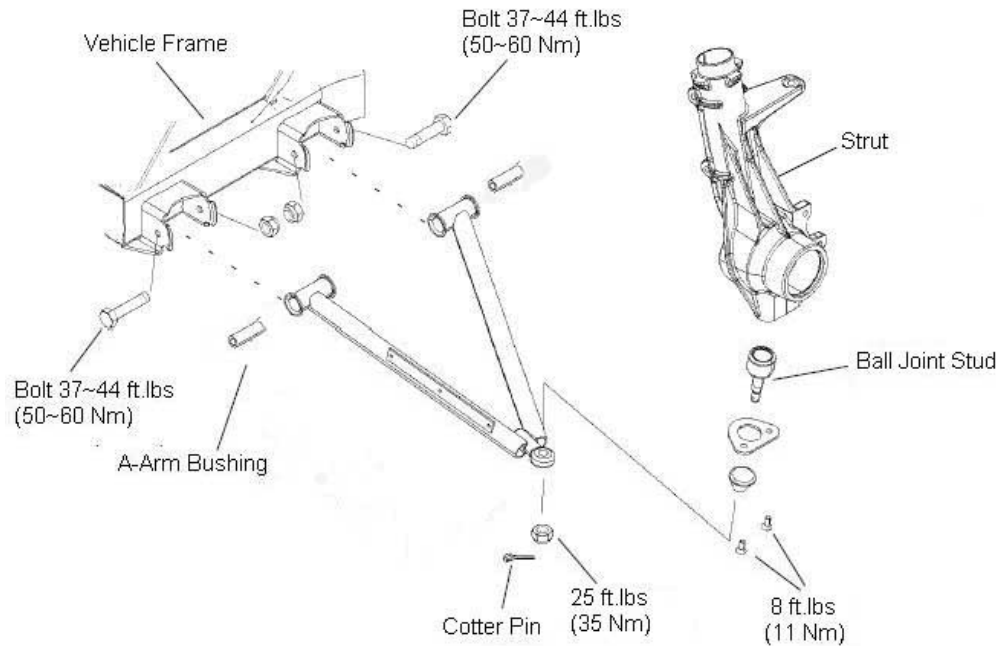
4.1 FRONT A-ARM REPLACEMENT

1. Elevate and safely support vehicle with weight removed from front wheel(s).
2. Remove cotter pin from ball joint stud at wheel end of A- arm and loosen nut until it is flush with end of stud.
3. Using a soft face hammer, tap nut to loosen A- arm from bolt. Remove nut and A-arm from hub strut assembly.
4. Loosen and remove two bolts on A-arm, and remove A-arm.
5. Examine A-arm bushing. Replace if worn or tore. Discard hardware.
6. Install new A-arm assembly onto vehicle frame. Install new bolts and new nuts.

NOTE:

Tighten the nuts only finger-tighten at this time. They will be tightened to the final torque after the front wheels are installed and the vehicle is on the ground.

⚠ WARNING

DO NOT reuse old bolts. Serious injury or death could result if fasteners come loose during operation.

7. Attach A-arm to strut assembly. Tighten ball joint nut to 25 ft. lbs. (35 Nm). If cotter pin holes are not aligned, tighten nut slightly to align. Install a new cotter pin with open ends toward rear of machine. Bend both ends in opposite directions around nut.
8. Install hubs, calipers and wheels, lower the vehicle to the ground. Apply Loctite™ 242 to screw threads of the A arm bolts and torque bolts to 37-44 ft. lbs. (50-60 Nm).

⚠ WARNING

Upon A-arm installation completion, test vehicle at low speeds before putting into regular service.

4.2 REAR A-ARM REPLACEMENT

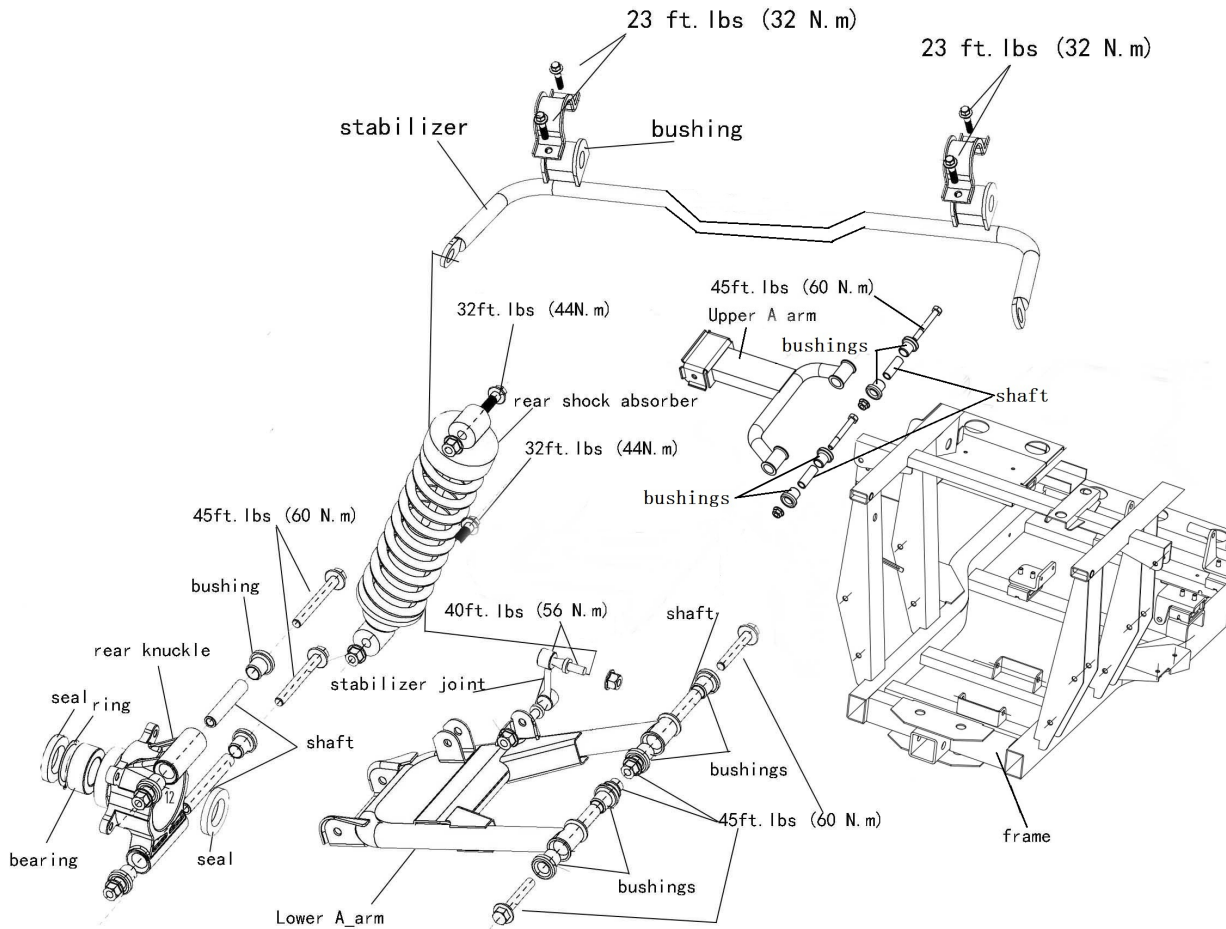

1. Elevate and safely support vehicle with weight removed from the rear wheel(s).

2. Remove the wheel nuts and wheel.
NOTE: To ease the removal of the spindle bolt, remove the hub cap and loosen the spindle bolts before removing the wheel.

3. Remove the hub cap, cotter pin, spindle bolt, and washer.

4. Remove the brake caliper. Suspend the brake caliper from the frame with a wire.
NOTE: Do not let the brake caliper hang from the brake line or damage may occur.



5. Loosen two bolts that secure the rear knuckle to the A-arm. Remove the rear knuckle assembly by sliding it off of the axle.



6. Remove the bolt that secures the shock absorber to the lower A-arm.

7. Remove the bolts that secure the upper A-arm to frame.



8. Remove the bottom stabilizer bar nut.

9. Remove the bolts that secure the lower A-arm to frame.

10. Examine all the A-arm bushings and A-arm shafts. Replace if worn. Discard hardware.

11. Insert new A-arm bushings and new A-arm shafts into new A-arm.

12. Install new A-arm assembly onto vehicle frame. Apply Loctite™ 242 to screw threads of the A arm bolts and torque bolts to 44 ft. lbs. (60 Nm).

⚠ WARNING

DO NOT reuse old bolts. Serious injury or death could result if fasteners come loose during operation.

13. Attach A-arm to rear knuckle. Tighten upper and lower bolts to 44 ft. lbs. (60 Nm).

14. Install the shock absorber and tighten shock bolt to 32 ft.lbs. (44 Nm).

15. Install the stabilizer and tighten nut to 40 ft.lbs. (56 Nm).

16. Re-install wheel and caliper.

⚠ WARNING

Upon A-arm installation completion, test vehicle at low speeds before putting into regular service.

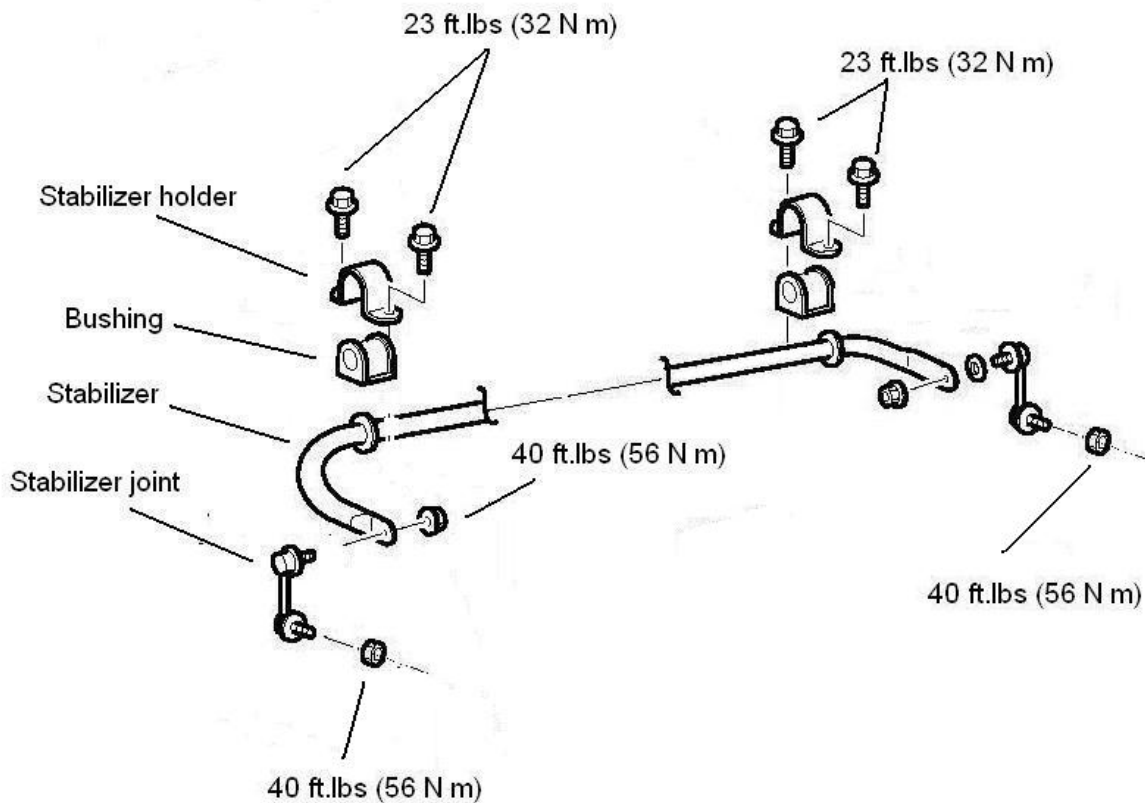
4.3 REAR STABILIZER BAR REMOVAL/INSTALLATION

1. Elevate and safely support vehicle with weight removed from the rear wheel(s).
2. Remove the rear wheel to gain access to the stabilizer bar, each side.
3. Remove the stabilizer bar nut from the lower A-arm, each side.
4. Remove the two bolts that secure the stabilizer bar to the main frame, each side.



5. Remove the stabilizer from the frame.
6. Inspect the stabilizer bar. Inspect the bushings and replace if needed.
7. Inspect the stabilizer joint and replace if needed.
8. Reverse the procedure for installation. Torque the stabilizer bolts to 23 ft.lbs (32 Nm).



4.4 FRONT STRUT REPLACEMENT

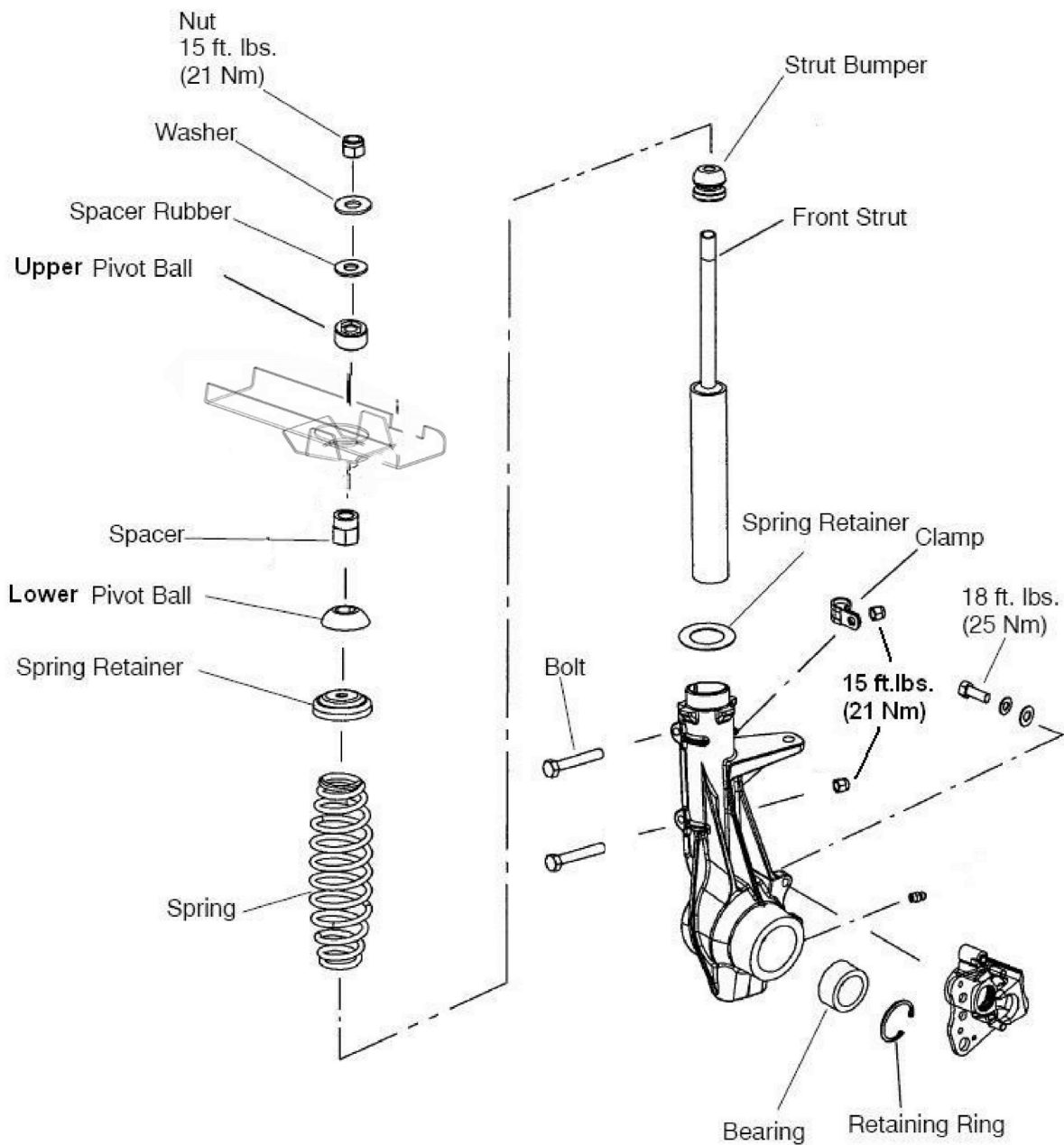

1. Hold strut rod with wrench and remove top nut.
2. Compress spring.
3. Remove all strut pivot assembly.
4. Remove coil spring and collapse strut body.
5. Remove two pinch bolts from strut body.
6. Remove strut body.
7. Install front shock cartridge until bottomed in strut casting.
8. Install pinch bolts with clamp(s). Torque pinch bolts to 18ft.lbs.(25Nm).
9. Reassemble spring and top pivot assembly. Be sure all parts are installed properly and seated fully.
10. Torque strut rod nut to specification. Do not over torque nut.

Strut Rod Nut Torque :15 ft. lbs. (21 Nm)

4.5 FRONT STRUT BALL JOINT REPLACEMENT

1. Loosen front wheel nuts.
2. Elevate and safely support CUV under footrest / frame area. .

CAUTION: Serious injury may result if CUV tips or falls. Be sure CUV is secure before beginning this service procedure.

3. Remove wheel nuts and wheels.
4. Remove cotter pin from ball joint
5. Remove castle nut and separate A-arm from ball joint stud.
6. Remove screws and ball joint mounting bracket.
7. Using ball joint cup removal/installation toolkit, remove ball joint cup from strut housing. Refer to photos at right.

- Install puller guide (1) .
- Thread bolt (2) with nut (3) onto ball joint stud as shown .
- Hold bolt (2) and turn nut (3) clockwise until ball joint is removed from strut housing.

8. To install new ball joint cup.
 - Insert new ball joint into driver (installation toolkit).
 - Drive new ball joint cup into strut housing until fully seated.
9. Apply Loctite 242 (blue) to threads of mounting bracket new screws.

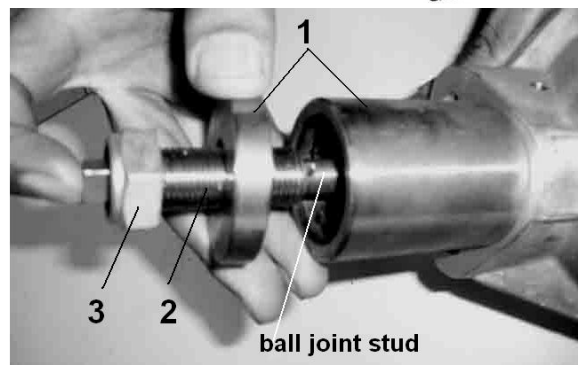
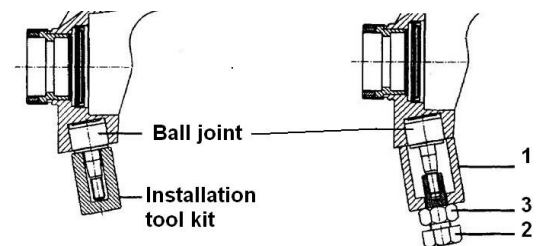
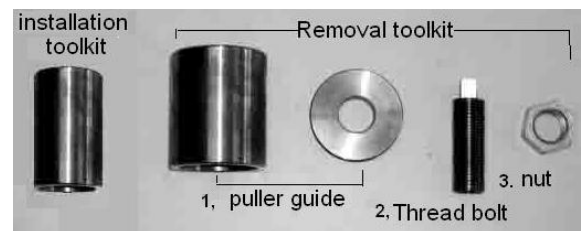
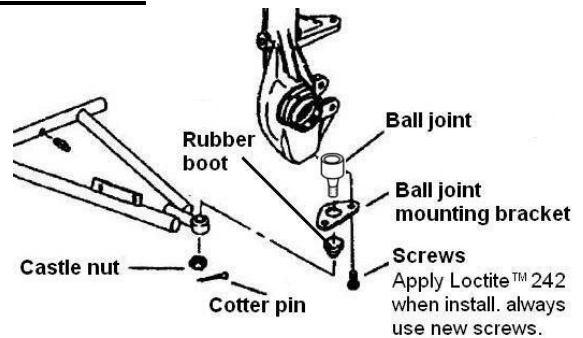

Torque screws to 8 ft.lbs. (11 Nm).

10. Install A-arm on ball joint cup and torque castle nut to 25 ft. lbs. (35 Nm).
11. Reinstall cotter pin with open ends toward rear of machine.

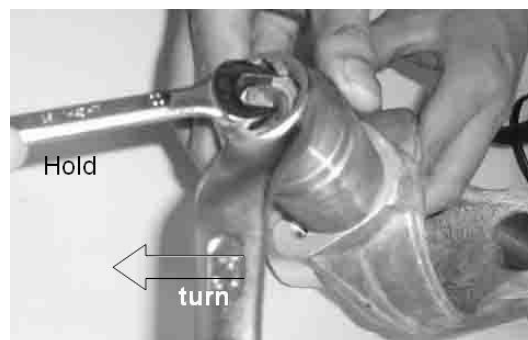

4.6 BOX REMOVAL/INSTALLATION

Box Removal

1. Disconnect the taillight coupler.
2. Lift the box into the dump position.
3. Remove the box shock pin from the frame (both sides).
4. Remove the shocks from the shock brackets. Let the shocks fully extend.

CAUTION: Safely support the box during the rest of the removal process. The box is not as stable with the shocks removed.

5. Remove the cotter pin from the hinge pin.
6. Remove the hinge pin (both sides).

CAUTION: Safely support the box during the rest of the removal process. The box is not as stable with the hinge pin removed.

7. With the hinge pins removed, remove the box from the frame. Two people may be needed to remove the bed from the frame.

CAUTION: Use caution when removing the box. It is recommended to have two people to carefully remove the box from the frame.

Box Installation

1. Place the box onto the frame. Align the hinges of the box with the frame.
2. Install the box hinges (both sides).
3. Secure the box hinges with the cotter pins (both sides).
4. With the hinges installed, decompress the box shocks and place them into the shock brackets on the frame (both sides).
5. Secure the box shocks with the shock pin (both sides).
6. Lower the box and secure the latch.
7. Connect the taillight coupler.

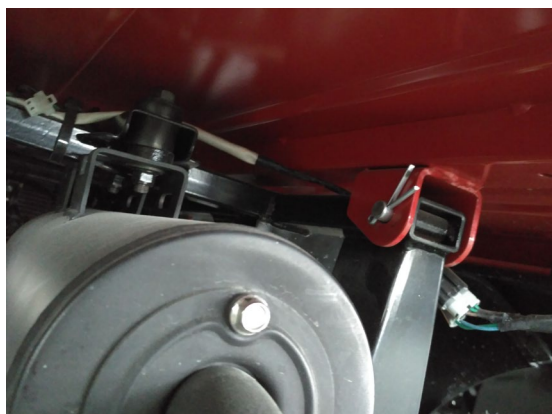

4.7 STEERING ASSEMBLY REMOVAL/INSTALLATION

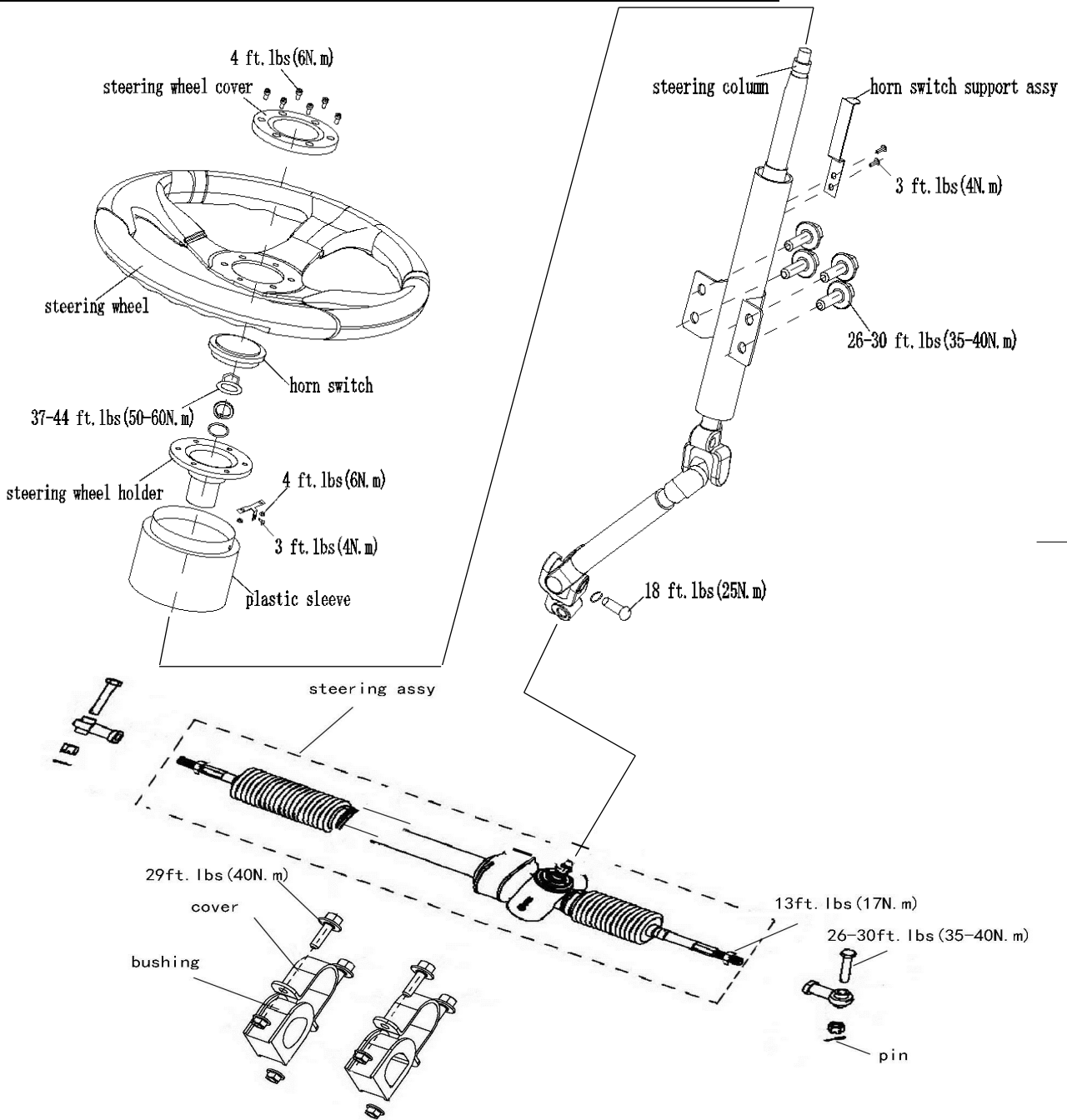

1. Remove the bolt and nuts that fixed the plastic sleeve.
2. With the steering wheel cover bolts removed, remove the steering wheel cover and steering wheel and horn switch.
3. With the steering wheel holder nut / spring washer / flat washer removed, remove the steering wheel holder and plastic sleeve.
4. With the steering column bolts removed, remove the upper of the steering column.
5. Remove the cotter pins and the tie rod end bolts (both sides).
6. With the cover bolts removed, remove the steering assy and the lower of the steering column.
7. Reverse the procedure for installation.

CHAPTER 5 FINAL DRIVE

WARNING

The parts of different types/ variants/ versions maybe un-interchangeable, even some parts have almost same appearance. Always refer to Parts Manual of each CUV model for spare parts information and service.

- 5.1 WHEEL, HUB, AND SPINDLE TORQUE TABLE
- 5.2 FRONT HUB EXPLODED VIEW
- 5.3 FRONT HUB REMOVAL/INSPECTION
- 5.4 FRONT HUB INSTALLATION
- 5.5 FRONT HUB BEARING REPLACEMENT
- 5.6 REAR HUB EXPLODED VIEW
- 5.7 REAR HUB AND KNUCKLE REMOVAL/INSPECTION
- 5.8 REAR HUB AND KNUCKLE INSTALLATION
- 5.9 REAR DRIVE SHAFT REMOVAL
- 5.10 REAR DRIVE SHAFT INSTALLATION

5.1 WHEEL, HUB, AND SPINDLE TORQUE TABLE

| Item | Specification |
|--|--------------------|
| Front Wheel Nuts | 59 Ft.Lbs 66 N.m |
| Rear Wheel Nuts | 59 Ft.Lbs 66 N.m |
| Front Hub Nut on Spindle/ outer CV joint | 101 Ft.Lbs 137 N.m |
| Rear Hub Retaining Nut | 101 Ft.Lbs 137 N.m |

Refer to exploded views and text for torque values of other fasteners.

CAUTION: Locking nuts, and bolts with pre-applied locking agent should be replaced if removed. The self- locking properties of the nut or bolt are reduced or destroyed during removal.

5.2 FRONT HUB EXPLODED VIEW

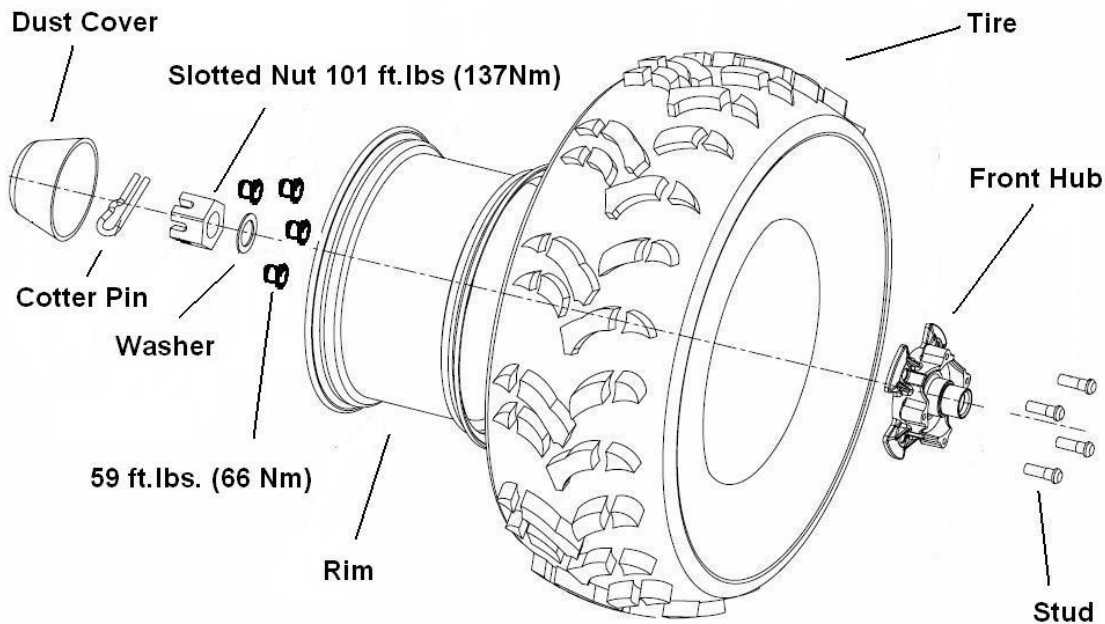

5.3 FRONT HUB REMOVAL/INSPECTION

1. Elevate front end and safely support machine under footrest / frame area.

CAUTION: Serious injury may result if machine tips or falls. Be sure machine is secure before beginning this service procedure. Wear eye protection when removing bearings and seals.

2. Check bearings for side play by grasping the tire/Wheel firmly and checking for movement.

3. Grasp the top and bottom of the tire. The tire should rotate smoothly without binding or rough spots.
4. Remove wheel nuts and wheel.
5. Remove the two brake caliper mounting bolts.

CAUTION: Do not hang the caliper by the brake line. Use wire to hang the caliper to prevent possible damage to the brake line.

6. Remove hub cap, cotter pin, front spindle nut, and washer, separate hub from front driveshaft.
7. Rotate break disc by hand and check for smooth rotation. Visually inspect bearing for moisture, dirt, or corrosion, or roughness is evident.

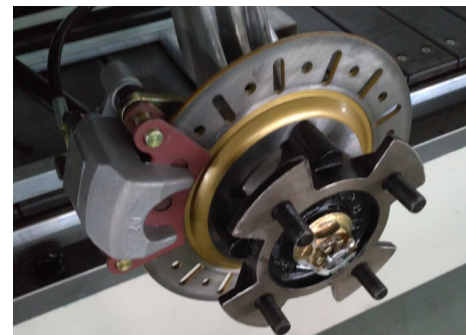
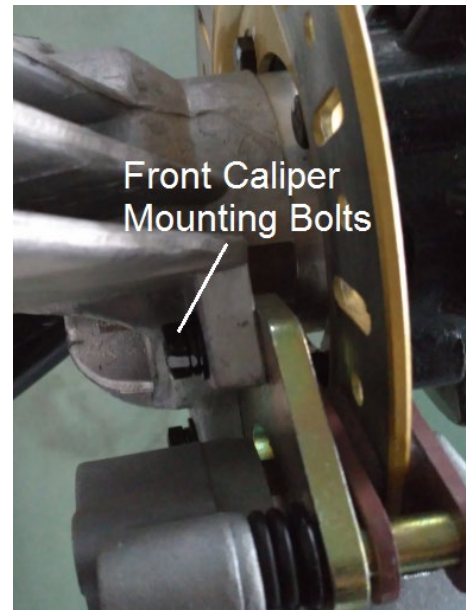

5.4 FRONT HUB INSTALLATION

1. Inspect the rotate bearing surface for wear or damage.
2. Install the hub into the bearing.
3. Apply grease to the spline of front driveshaft. Install driveshaft through the backside of the HUB.
4. Install washer and spindle nut and tighten to 101 ft.lbs (137 N.m).
5. Install a new cotter pin. Tighten nut slightly if necessary to align cotter pin holes. bend both ends of cotter pin around end of spindle in different directions. Install hub cap.

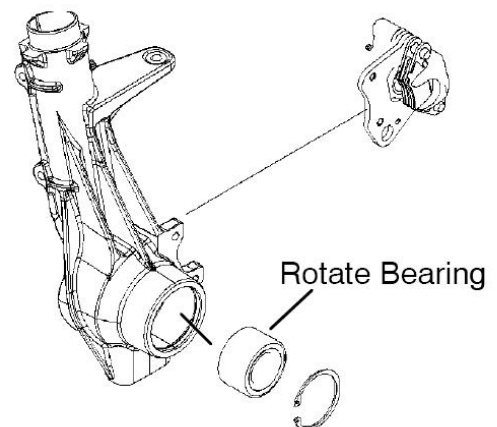

6. Rotate hub. It should rotate smoothly without binding or rough spots or side play.

7. Install brake caliper using new bolts. (Apply Loctite™ 242 to threads) Tighten bolts to 18 ft.lbs (25 N.m)

CAUTION: New bolts have a pre-applied locking agent which is destroyed bolts upon removal. Always use new brake caliper mounting bolts upon assembly.

8. Install wheel and wheel nuts and tighten evenly in a cross pattern to specified torque.

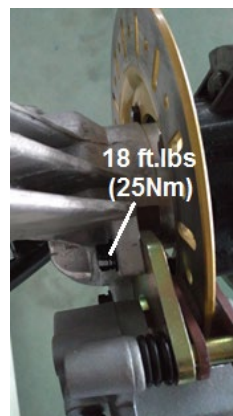

5.5 FRONT HUB BEARING REPLACEMENT

1. Remove outer snap ring.

2. From the back side, tap on the outer bearing race with a drift punch in the reliefs as shown.

3. Drive bearing out evenly by tapping on outer race only. Once bearing is at bottom of casting, support casting on outer edges so bearing can be removed.



4. Inspect bearing.

NOTE: Due to extremely close tolerances and minimal wear, the bearings must be inspected visually, and by feel. While rotating bearings by hand, inspect for rough spots, discoloration, or corrosion. The bearings should turn smoothly and quietly, with no detectable up and down movement and minimal movement sideways between inner and outer race.



5. Inspect bearing housing for scratches, wear or damage. Replace housing if damaged.

5.6 REAR HUB EXPLODED VIEW

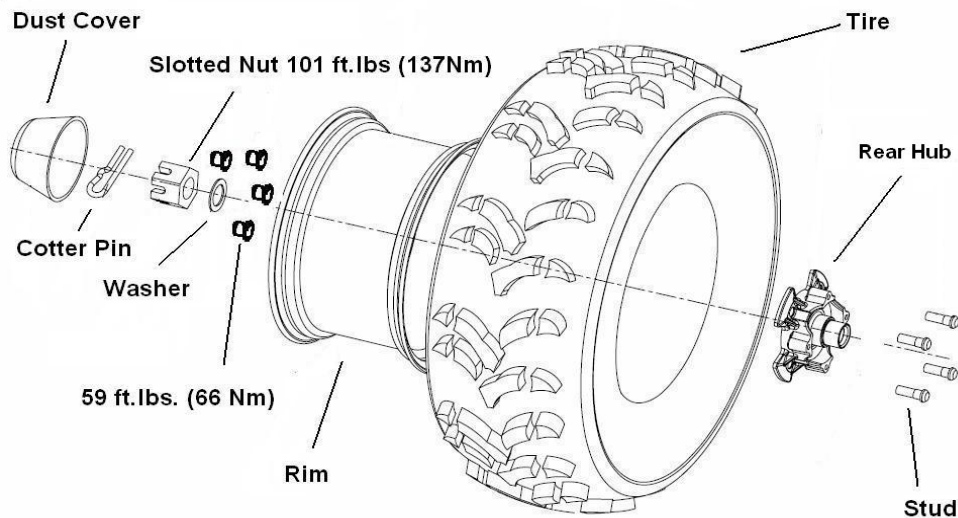

5.7 REAR HUB AND KNUCKLE REMOVAL/INSPECTION

1. Elevate rear end and safely support machine under main frame area.

CAUTION: Serious injury may result if machine tips or falls. Be sure machine is secure before beginning this service procedure. Wear eye protection when removing bearings and seals.

2. Check bearings for side play by grasping the tire/wheel firmly and checking for movement. Grasp the top and bottom of the tire. The tire should rotate smoothly without binding or rough spots.



3. Remove wheel nuts and wheel.

4. Remove the two brake caliper attaching bolts.

CAUTION: Do not hang the caliper by the brake line. Use wire to hang the caliper to prevent possible damage to the brake line.

5. Remove hub cap, cotter pin, rear spindle nut, and washer.



6. Remove the upper and lower control arm bolts.
7. Slide the rear hub and knuckle from the rear drive shaft.
8. Inspect the rear hub and knuckle assembly by hand for smoothness and side to side movement, replace as needed.



5.8 REAR HUB AND KNUCKLE INSTALLATION

1. Install the rear hub and knuckle assembly onto the drive shaft.
2. Align the bottom of knuckle and lower control arm. Secure with the lower control arm bolt.
3. With the driveshaft placed in the knuckle, align the knuckle with the top control arm. Secure with the upper control arm bolt.
4. Tighten upper and lower bolts to 45 ft.lbs (60 N.m).
5. Install the washer and the spindle retainer nut, tighten bolts to 101 ft.lbs (137 N.m), install a new cotter key and hub cap.
6. Install brake caliper using new bolts. (Apply Loctite™ 242 to threads) Tighten bolts to 18 ft.lbs (25 N.m).
7. Install the wheel and wheel nuts. Torque wheel nuts to 59 ft.lbs. (66 N.m).

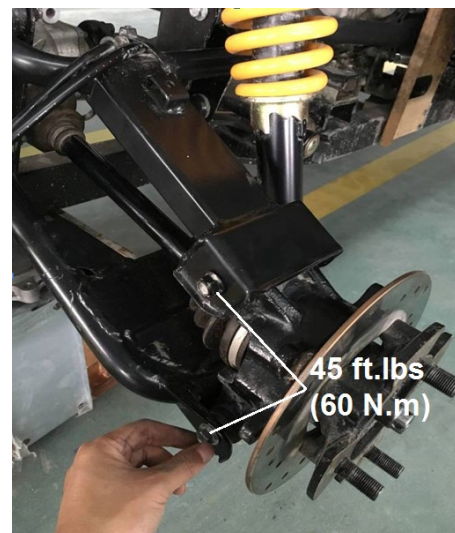

5.9 REAR DRIVE SHAFT REMOVAL

1. Repeat of the steps in the "REAR HUB AND KNUCKLE REMOVAL" section.
2. Pull the rear drive shaft straight out of the frame. Use short sharp jerks to free the circlip from the gearcase. (The circlip holds the shaft in the gearcase)



3. Inspect the shaft splines and cv boots for any damage.



5.10 REAR DRIVE SHAFT INSTALLATION

1. Install a new circlip onto the rear drive shaft. Apply Anti-Seize Compound onto the rear driveshaft splines (both ends).
2. Reinstall the rear driveshaft into the rear gearcase. Be sure the circlip is securely fit into the rear gearcase. Use a rubber mallet to tap on the outboard end of the driveshaft if necessary.

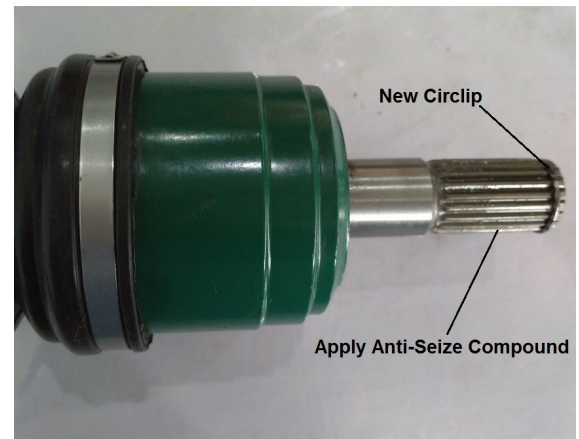

3. Slide the rear drive shaft into the knuckle.
4. Lift knuckle into place and install bolt to upper and lower control arm. Torque bolt to 45 ft.lbs (60 N.m).
5. Install the washer and the spindle retainer nut, tighten bolts to 101 ft.lbs (137 N.m), install a new cotter key and hub cap.
6. Install brake caliper using new bolts. (Apply Loctite™ 242 to threads) Tighten bolts to 18 ft.lbs (25 N.m).
7. Install the wheel and wheel nuts. Torque wheel nuts to 59 ft.lbs. (66 N.m).

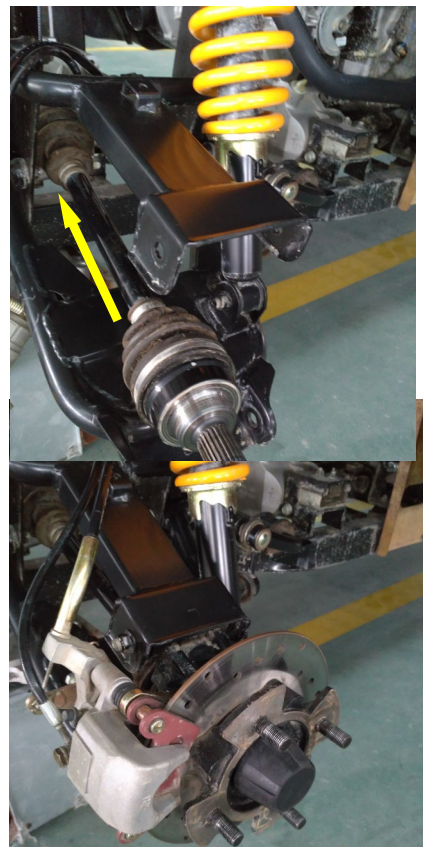

CHAPTER 6 BRAKES

WARNING

The parts of different types/ variants/ versions maybe un-interchangeable, even some parts have almost same appearance. Always refer to Parts Manual of each ATV model for spare parts information and service.

NOTE: Also See Chapter 2 for Maintenance Information.

6.1 SPECIFICATIONS

6.2 TORQUE

6.3 BRAKE SYSTEM SERVICE NOTES

6.4 BURNISHING PROCEDURE

6.5 BRAKE BLEEDING-FLUID CHANGE

6.6 PARKING BRAKE AND BRAKE LINE INSPECTION

6.7 PARKING BRAKE ADJUSTMENT

6.8 REAR PADS REMOVAL/INSTALL

6.9 FRONT PADS INSPECTION / REMOVAL / REPLACEMENT

6.10 FRONT DISC INSPECTION / REMOVAL / REPLACEMENT

6.11 FRONT CALIPER REMOVAL/ INSPECTION / INSTALLATION

6.12 REAR CALIPER REMOVAL/ INSPECTION/ INSTALLATION

6.13 REAR BRAKE DISC INSPECTION / REMOVAL / REPLACEMENT

6.1 SPECIFICATIONS

| Front Brake Caliper | | |
|--|-------------------------------|----------------------|
| Item | Standard | Service Limit |
| Brake Pad Friction material Thickness | 0.157"/ 4mm | 0.04"/ 1mm |
| Brake Disc Thickness | 0.150- 0.164"/3.810- 4.166mm | 0.140"/ 3.556mm |
| Brake Disc Thickness Variance Between Measurements | - | 0.002 " / .051m m |
| Brake Disc Runout | - | 0.005 " / .127mm |
| Rear Brake Caliper | | |
| Item | Standard | Service Limit |
| Brake Pad Friction material Thickness | hydraulic | 0.04"/ 1mm |
| | Hydraulic with mechanics park | |
| | mechanics park | |
| Brake Disc Thickness | 0.177-0.187"/4.496-4.750m m | 0.167"/4.242mm |
| Brake Disc Thickness Variance Between Measurements | - | 0.002 " / 0.051mm |
| Brake Disc Run out | - | 0.005 " / 0.127mm |

6.2 TORQUE

| Item | Torque (ft. lbs. except where noted*) | Torque (N.m) |
|------------------------------|--|--------------------------|
| Front Caliper Mounting Bolts | 18.0 | 25 |
| Rear Caliper Mounting Bolts | 18.0 | 25 |
| Front Brake Disc | 18.0 | 25 |
| Rear Brake Disc | 18.0 | 25 |

6.3 BRAKE SYSTEM SERVICE NOTES

- It is strongly recommended always change the caliper and (or) the master cylinder as an assembly. The parts inside maybe not interchangeable due to different brake manufactures and (or) different brake type.
- Do not over – fill the master cylinder fluid reservoir.
- Make sure the brake lever and pedal returns freely and completely.
- Check and adjust master cylinder reservoir fluid level after pad service.
- Make sure atmospheric vent on reservoir is unobstructed.

- Adjust foot brake after pad service.
- Test for brake drag after any brake system service and investigate cause if brake drag is evident.
- Make sure caliper moves freely on guide pins (where applicable) .
- Inspect caliper piston seals for foreign material that could prevent caliper pistons from returning freely.
- Perform a brake burnishing procedure after install new pads to maximize service life.
- DO NOT lubricate or clean the brake components with aerosol or petroleum products. Use only approved brake cleaning products.

6.4 BURNISHING PROCEDURE

Brake pads (both hydraulic and mechanical) must be burnished to achieve full braking effectiveness. Braking distance will be extended until brake pads are properly burnished. To properly burnish the brake pads, use the following procedure.

1. Choose an area large enough to safely accelerate the CUV to 50 km/h (30 mph) and to brake to stop.
2. Using hi gear, accelerate to 50 km/h (30 mph); then compress brake lever (pedal) to decelerate to 0-8km/h (5 mph).
3. Repeat procedure on each brake system 20 times until brake pads are burnished.
4. Adjust the mechanical parking brake (if necessary).
5. Verify that the brake light illuminates when th e hand lever is compressed or the brake pedal is depressed.

WARNING

Failure to properly burnish the brake pads could lead to premature brake pad wear or brake loss. Brake loss can result in severe injury.

6.5 BRAKE BLEEDING-FLUID CHANGE

NOTE: When bleeding the brakes or replacing the fluid always start with the caliper farthest from the master cylinder.

CAUTION:

Always wear safety glasses.

CAUTION:

Brake fluid is highly corrosive. Do not spill brake fluid on any surface of the CUV. This procedure should be used to change fluid or bleed brakes during regular maintenance.

1. Clean reservoir cover thoroughly.
2. Remove cover from reservoir.
3. If changing fluid, remove old fluid from reservoir with a brake fluid pump or similar tool.
4. Add brake fluid between the MIN line and MAX line of reservoir.

DOT 3 Brake Fluid

5. Begin bleeding procedure with the caliper that is farthest from the master cylinder. Install a box end wrench on the caliper bleeder screw. Attach a clean, clear hose to the fitting and place the other end in a clean container. Be sure the hose fits tightly on the fitting.
 6. Slowly pump foot pedal until pressure builds and holds.
 7. Hold brake pedal on to maintain pedal pressure, and open bleeder screw. Close bleeder screw and release foot pedal.
- NOTE:** Do not release foot pedal before bleeder screw is tight or air may be drawn into master cylinder.
8. Repeat procedure until clean fluid appears in bleeder hose and all air has been purged. Add fluid as necessary to maintain level in reservoir.

CAUTION:

Maintain at least 1/2 " (13mm) of brake fluid in the reservoir to prevent air from entering the master cylinder.

9. Tighten bleeder screw securely and remove bleeder hose.
10. Repeat procedure steps 5- 9 for the remaining calipers.
11. Add brake fluid to MAX level inside reservoir.

Master Cylinder Fluid Level

Between the MIN line and the MAX line of reservoir.

12. Install master cylinder reservoir cover.
13. Field test machine at low speed before putting into service. Check for proper braking action and pedal reserve. With pedal firmly applied, pedal reserve should be no less than 1/2 " (13mm).
14. Check brake system for fluid leaks and inspect all hoses and lines for wear or abrasion. Replace hose if wear or abrasion is found.

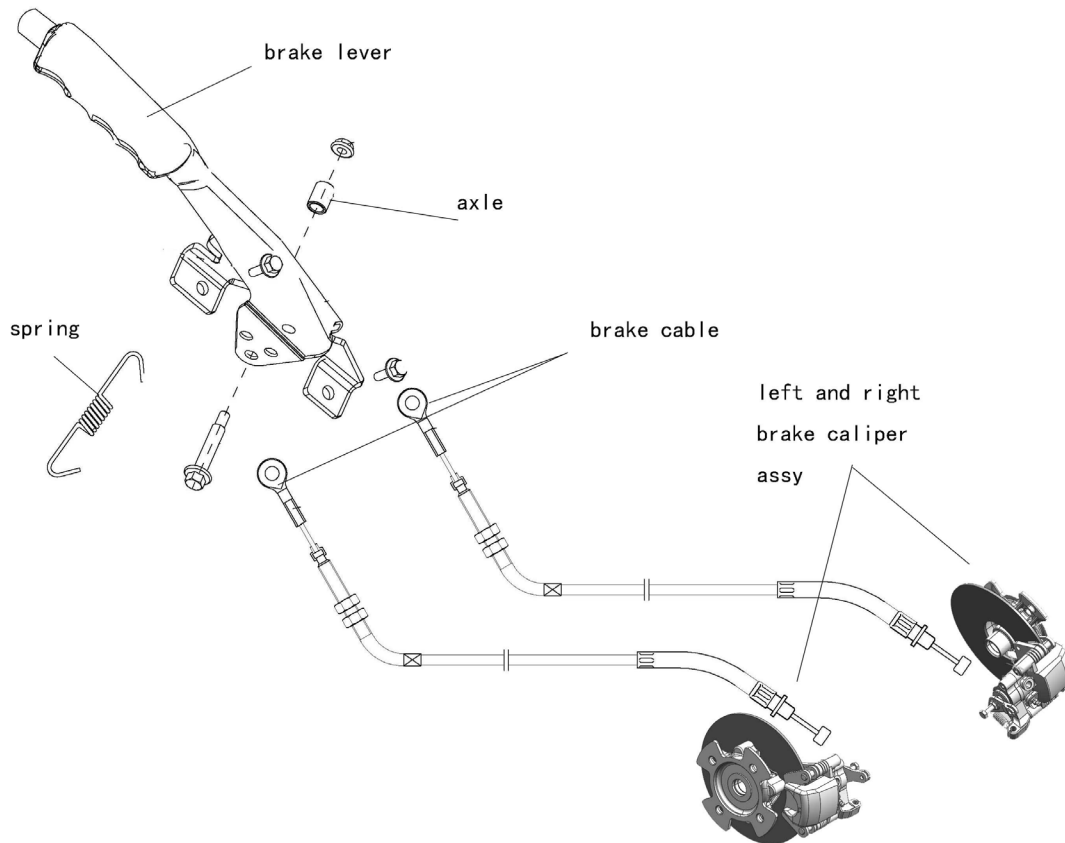

6.6 PARKING BRAKE AND BRAKE LINE INSPECTION

1. Inspect the spring on the parking brake lever assembly.
2. Inspect the parking brake cable at the parking brake lever assembly on the brake caliper.
3. Inspect the brake lines and brake line connections for possible leaks or loose lines.

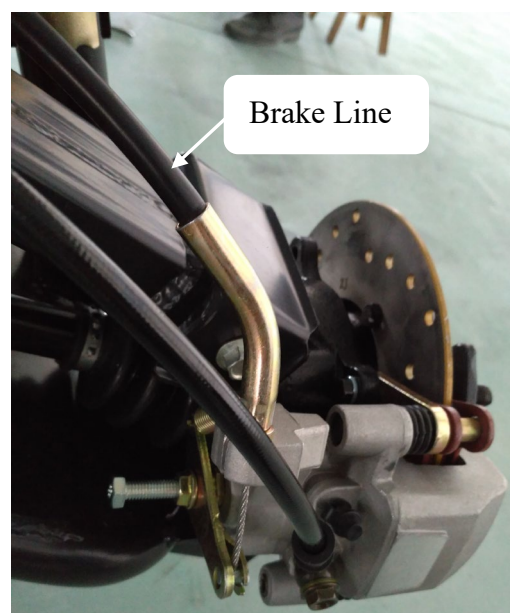

6.7 PARKING BRAKE ADJUSTMENT

Parking Brake Inspection

1. Push the parking brake up with your hand.
2. After 7 to 9 clicks of lever travel, the vehicle should not roll while parked.
3. If the vehicle moves, adjustment is necessary.
4. Adjust the parking brake where the cable attaches to the lever assembly on the rear brake caliper.



Parking Brake Adjustment

1. Place the vehicle in neutral on a flat level surface.
2. Carefully lift the rear of the vehicle off the ground and stabilize on jack stands.
3. Loosen the jam nut on the rear caliper adjustment bolt.
4. Tighten the adjustment bolt until the rear tire will not rotate.
5. Back off the adjustment bolt 1/4 turn.
6. Tighten the jam nut while holding the adjustment nut in place.

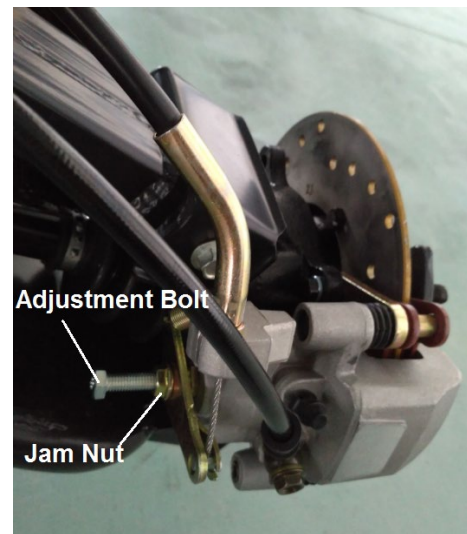

6.8 REAR PADS REMOVAL / INSTALL

NOTE: The brake pads should be replaced as a set.

1. Elevate and support rear of CUV safely.

CAUTION:

Be care when supporting vehicle so that it does not tip or fall. Severe injury may occur if machine tips or falls.

2. Remove the rear wheels.
3. Remove the two caliper bolts and caliper from mounting bracket.

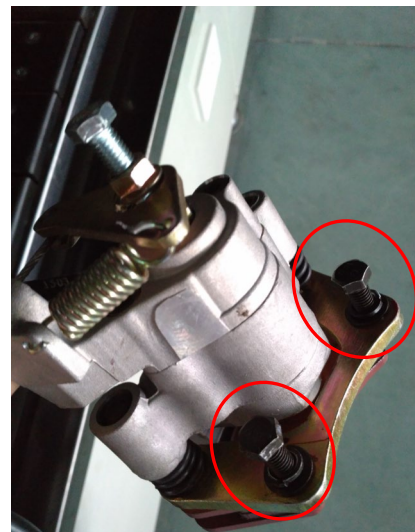

4. Measure the thickness of the caliper parking brake pads. Replace pads if worn beyond the service limit.

Service Limit 3/64"(1 mm)

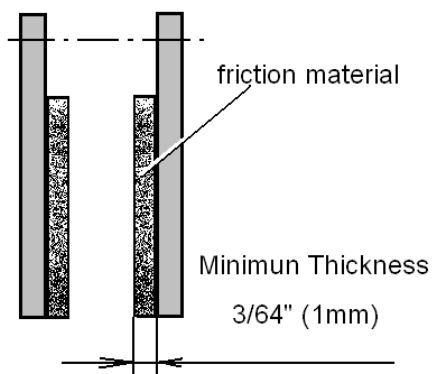

The Procedure of Pads Replacement

1. Push caliper piston into caliper bore slowly using a C-clamp or locking pliers with pads installed.

NOTE: Brake fluid will be forced through compensating port into master cylinder fluid reservoir when piston is pushed back into caliper. Remove excess fluid from reservoir as required.

2. Push mounting bracket inward and slip outer brake pad past edge. Remove inner pad.



3. Lubricate mounting bracket pins with a light film of All Season Grease, and install rubber dust boots.

4. Compress mounting bracket and make sure dust boots are fully seated. Install pads with friction material facing each other.

NOTE: Do not get oil, grease or fluid on the park brake pads. Damage to the pads may cause the pads to function improperly.



Rear Brake Caliper Installation

1. Install the park brake assembly into place. Tighten the two bolts for proper installation.
2. Torque the two bolts to 18 ft.lbs. (25 N.m).
3. Test the park brake for proper function.

6.9 FRONT PADS REMOVAL / INSPECTION / INSTALLATION

NOTE: The brake pads should be replaced as a set.

REMOVAL

1. Elevate and support front of CUV safely.

CAUTION:

Be care when supporting vehicle so that it does not tip or fall. Severe injury may occur if machine tips or falls.

2. Remove the front wheels.
3. Remove the two caliper bolts and caliper from mounting bracket.

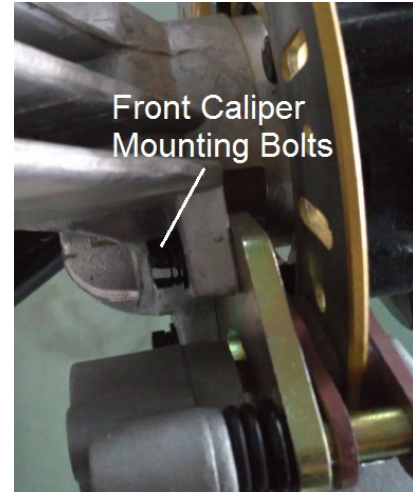

INSPECTION

Measure the thickness of the pads friction material. Replace pads if worn beyond the service limit.

Service Limit 3/64"(1 mm)

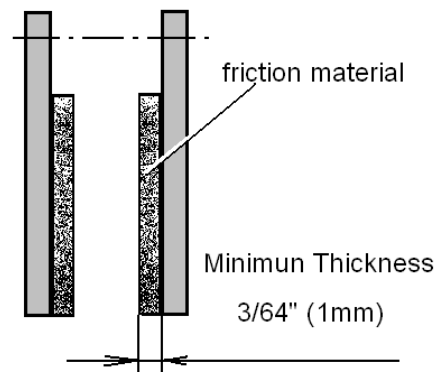

The procedure of pads replacement

1. Repeat of the **Replacement Steps** in the "REAR PADS REMOVAL / INSTALL" section.

Front Caliper Installation

1. Install caliper on hub strut, and torque mounting bolts.
Front Caliper Mounting Bolts Torque 18 ft. lbs. (25 N.m)

NOTE: The Following Procedure Should Be Done After Front / Rear Brake Pads Replacement.

1. Slowly pump the brake lever until pressure has been built up. Maintain at least 1/2 "(13 mm) of brake fluid in the reservoir to prevent air from entering the brake system.
2. Turn the adjustment bolt clockwise until stationary pad contacts disc, then back off 1/4 turn (counter clockwise), then lock the jam nut.
3. Be sure fluid level in reservoir is up to MAX line inside reservoir and install reservoir cap.
4. Install wheels and torque wheel nuts.
5. It is recommended that a burnishing procedure be performed after installation of new brake pads to extend service life and reduce noise. Start machine and slowly increase speed to 30 mph. Gradually apply brakes to stop machine. Repeat procedure 10 times.

6.10 FRONT DISC INSPECTION / REMOVAL / REPLACEMENT**INSPECTION**

1. Visually inspect the brake disc for nicks, scratches, or damage.
2. Measure the disc thickness at 8 different points around the pad contact surface using a 0-1" micrometer and a dial indicator. Replace disc if worn beyond service limit.

Brake Disc Thickness**New 0.150-0.164" (3.810 - 4.166 mm)****Service Limit 0.140" / 3.556 mm****Brake Disc Thickness Variance****Service Limit 0.002 " (0.051 mm)****difference between measurements**

3. Mount dial indicator as shown to measure disc runout on the dial indicator. Replace the disc if runout exceeds specifications.

Brake Disc Runout**Service Limit 0.005" (0.127 mm)****REMOVAL/ REPLACEMENT**

1. Remove caliper and hub. Apply heat to the hub in the area of the brake disc mounting bolts to soften the bolt.
2. Remove bolts and disc.
3. Clean mating surface of disc and hub.
4. Install new disc on hub and tighten to specified.

Front Brake Disc Mounting Bolt Torque**18 ft. lbs (25 N.m)****CAUTION:**

Always use new brake disc mounting bolts.



6.11 FRONT CALIPER REMOVAL/ INSPECTION / INSTALLATION**CAUTION:**

The caliper is a non-serviceable Component, it must be replaced as an assembly.

NOTE: If any special service needed, contact the CUV manufacture via the agent for the parts and special instruction.

REMOVAL

1. Remove wheel, remove caliper from the strut.
2. Loosen and remove brake hose to caliper. Place a container under caliper to catch fluid draining.

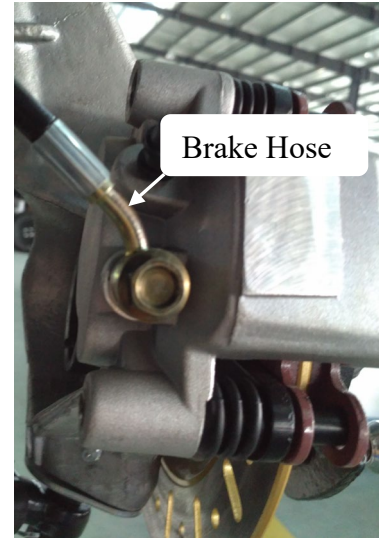
**INSPECTION**

Inspect caliper body for nicks, scratches or worn. Replace caliper as an assembly if any problem exists.

INSTALLATION

1. Install caliper on hub strut, Apply Loctite™ 242 to screw threads and Install new bolts.
Front Caliper Mounting Bolt Torque: 18 ft. lbs (25 N.m)
2. Install brake hose and tighten to specified torque.
Bolt Torque: 15 ft. lbs (21 N.m)

NOTE: If new brake pads are installed, it is recommended that a burnishing procedure be performed after installation of new brake pads to extend service life and reduce noise. Start machine and slowly increase speed to 30 mph. Gradually apply brakes to stop machine. Repeat procedure 10 times.

6.12 REAR CALIPER REMOVAL/ INSPECTION/ INSTALLATION**CAUTION:**

The caliper is a non-serviceable Component; it must be replaced as an assembly.

NOTE: If any special service needed, contact the CUV manufacture via the agent for the parts and special instruction.

1. Safely support the rear of the machine.
2. Remove the brake hose and park brake line. Place a container to catch brake fluid draining

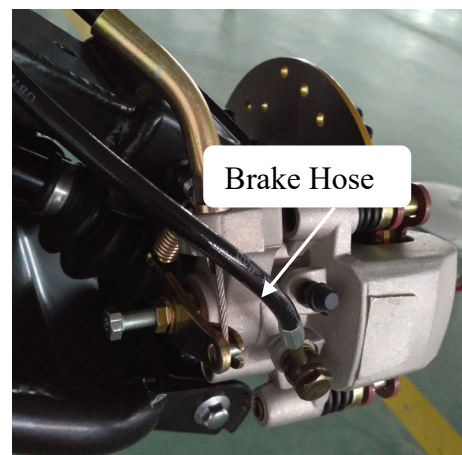

from brake hose.

3. After the fluid has drained into the container, remove the caliper mounting bolts and remove caliper.
4. Remove brake pads as described above.
5. Inspect surface of caliper for nicks, scratches or damage and replace if necessary.
6. Install brake pads in caliper body with friction material facing each other, with the spacer between the pads. Install retaining pin through outer pad, pad spacer and inner pad.
7. Install caliper and torque mounting bolts to 18 ft.lbs (25 N.m).
8. Install park brake line, brake hose and tighten to specified torque.
Bolt Torque: 15 ft. lbs(21 N.m)
9. Field test unit for proper braking action before putting into service. Inspect for fluid leaks and firm brakes. Make sure the brake is not dragging when lever is released. If the brake drags, recheck assembly and installation.
10. Install the rear wheel and wheel nuts. Carefully lower the vehicle.

NOTE: If new brake pads are installed, it is recommended that a burnishing procedure be performed after installation of new brake pads to extend service life and reduce noise.

6.13 REAR BRAKE DISC INSPECTION / REMOVAL / REPLACEMENT

INSPECTION

1. Visually inspect the brake disc for nicks, scratches, or damage.
2. Measure the disc thickness at 8 different points around the pad contact surface using a 0-1" micrometer and a dial indicator. Replace disc if worn beyond service limit.

Brake Disc Thickness

New 0.150-0.164" (3.810 - 4.166 mm)

Service Limit 0.140" / 3.556 mm

Brake Disc Thickness Variance

Service Limit 0.002 " (0.051 mm)

difference between measurements

3. Mount dial indicator to measure disc runout on the dial indicator. Replace the disc if runout exceeds specifications.

Brake Disc Runout Service Limit 0.005" (0.127 mm)

REMOVAL/ REPLACEMENT

1. Removal wheel/ hub and caliper.
2. Remove bolts and disc from the flange.
3. Clean mating surface of disc and hub.
4. Install new disc on flange.
Rear Brake Disc Mounting Bolt Torque : 18 ft. lbs (25 N.m)

CAUTION:

Always use new brake disc mounting bolts.

CHAPTER 7 ELECTRICAL

- 7.1 PARTS INSPECTION AND SERVICE
- 7.2 BATTERY
- 7.3 IGNITION SYSTEM
- 7.4 CHARGING SYSTEM
- 7.5 ELECTRICS STARTING SYSTEM
- 7.6 COOLING SYSTEM
- 7.7 LIGHTING SYSTEM
- 7.8 REVERSE LIMIT SYSTEM
- 7.9 GEAR POSITION INDICATOR SWITCH TEST
- 7.10 SPEEDOMETER SYSTEM
- 7.11 MAIN SWITCH AND HANDLE SWITCH
- 7.12 FUEL GAUGE/ FUEL LEVEL SENSOR
- 7.13 THE OPERATION PRINCIPLE OF THE ELECTRIC 4WD SHIFT
- 7.14 WIRING DIAGRAM

7.1 PARTS INSPECTION AND SERVICE**A HEADLIGHT ADJUSTMENT**

1. Use bulb 12V 35W/35W.
2. Remove the black sheath, turning the socket counterclockwise and take it out.
Turning the bulb counterclockwise and Remove it from the socket.
3. Change the bulb.

**HEADLIGHT ADJUSTMENT**

1. The headlight beam can be adjusted vertically.
2. Place the vehicle on a level surface with the headlight approximately 33in(10m) from a wall.
3. Measure the distance from the floor to the center of the headlight and make a mark on the wall at the same height.
4. Start the engine and turn the headlight switch to high beam.
5. Observe headlight aim. The most intense part of the headlight beam should be aimed 86mm to 129mm below the mark placed on the wall in step 2.
NOTE : Riding weight must be included on the seat.
6. Loosen but not remove pivot bolt/ screw and adjust beam to desired position.
7. Tighten nut and bolt / screw.



To turn the two adjusting screws backward is to lower the beam. To turn the two adjusting screws forward is to heighten the beam.

TAILLIGHT / BRAKELIGHT LAMP REPLACEMENT

1. From the rear of the taillight remove two screws holding lens cover in place and remove lens cover.
2. Remove lamp and replace it with recommended lamp.
3. Reinstall the lens cover removed in step 1.
4. Test the taillight / brake light.

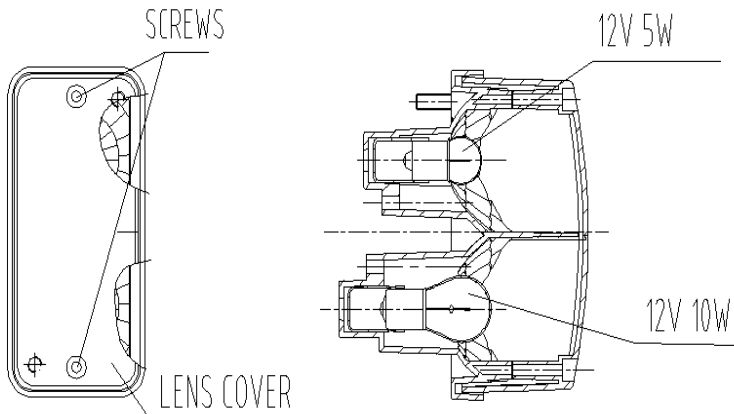

7.2 BATTERY

Battery electrolyte is poisonous. It contains sulfuric acid. Serious burns can result from contact with skin, eyes or clothing Antidote:

External: Flush with water.

Internal: Drink large quantities of water or milk. Follow with milk of magnesia, beaten egg, or vegetable oil. Call physician immediately.

Eyes: Flush with water for 15 minutes and get prompt medical attention.

Batteries produce explosive gases. Keep sparks, flame, cigarettes, etc. away.

Ventilate when charging or using in an enclosed space. Always shield eyes when working near batteries.

KEEP OUT OF REACH OF CHILDREN

INSTRUCTIONS FOR SEALED TYPE DRY CHARGED STORAGE BATTERY

This battery is dry and charged, which means that it starts operating when being filled with the electrolyte and sealed with the sealing plugs.

To fill the electrolyte proceed as follows:

- (1) Place the battery on a level place, and tear down the sealed tape on even place.
- (2) Softly inlay the filling funnel on the ports the storage battery.
- (3) Take out the electrolyte container. Put it down straightly. Then pour through the funnel to the ports.

CAUTION: Unless the electrolyte container is pushed in straightly, the battery may fall down, from which spillages may cause loss of eyesight and/or burns.

- (4) Be sure that bubbles are generating in all 6 cells of the electrolyte container and the level of electrolyte should be down.

CAUTION: If there is any cell which does not produce bubbles, tap it softly with finger and filling will start.

Removing the electrolyte container from the battery is not necessary.

BATTERY TESTING

Whenever a service complaint is related to either the starting or charging systems, the battery

should be checked first.

Following are three tests which can easily be made on a battery to determine its condition: OCV Test, Specific Gravity Test and Load Test.

MF (Maintenance Free) battery does not require the Specific Gravity Test and Refill**Open Circuit Voltage Test**

Battery voltage should be checked with a multimeter

NOTE: Lead acid batteries should be kept at or near a full digital multimeter. Readings of 12.6 or less require further battery testing and charging. charge as possible.

Load test

CAUTION: Remove spark plug high tension leads and connect securely to engine ground before proceeding.

NOTE: This test can only be performed on machines with electric starters. This test cannot be performed with an engine or starting system that is not working properly.

A battery may indicate a full charge condition in the OCV test and the specific gravity test, but still may not have the storage capacity necessary to properly function in the electrical system. For this reason, a battery capacity or load test should be conducted whenever poor battery performance is encountered. To perform this test, hook a multimeter to the battery in the same manner as was done in the OCV test. The reading should be 12.6 volts or greater. Engage the electric starter and view the registered battery voltage while cranking the engine. Continue the test for 15 seconds. During this cranking period, the observed voltage should not drop below 9.5 volts. If the beginning voltage is 12.6 or higher and the cranking voltage drops below 9.5 volts during the test, replace the battery.

7.3 IGNITION SYSTEM

IGNITION SYSTEM TROUBLESHOOTING

No Spark, Weak or Intermittent Spark

- Spark plug gap incorrect
- Fouled spark plug
- Faulty spark plug cap or poor connection to high tension lead
- Related wiring loose, disconnected, shorted, or corroded
- Emergency switch faulty
- Terminal board or connections wet, corroded
- Poor ignition coil ground (e.g. coil mount loose or corroded)
- Faulty stator (measure resistance of all ignition related windings)
- Incorrect wiring (inspect color coding in connectors etc.)
- Faulty ignition coil winding (measure resistance of primary and secondary)
- Worn magneto (RH) end crankshaft bearings
- Sheared flywheel key
- Flywheel loose or damaged
- Trigger coil air gap too wide (where applicable) should be 0.030-0 .050" (0. 75-1.25 mm)
- Excessive crankshaft run out on magneto (RH) end should not exceed 0.005" (0.13mm)
- Faulty ECU module
- Faulty Electric relay

CIRCUIT DIAGRAM

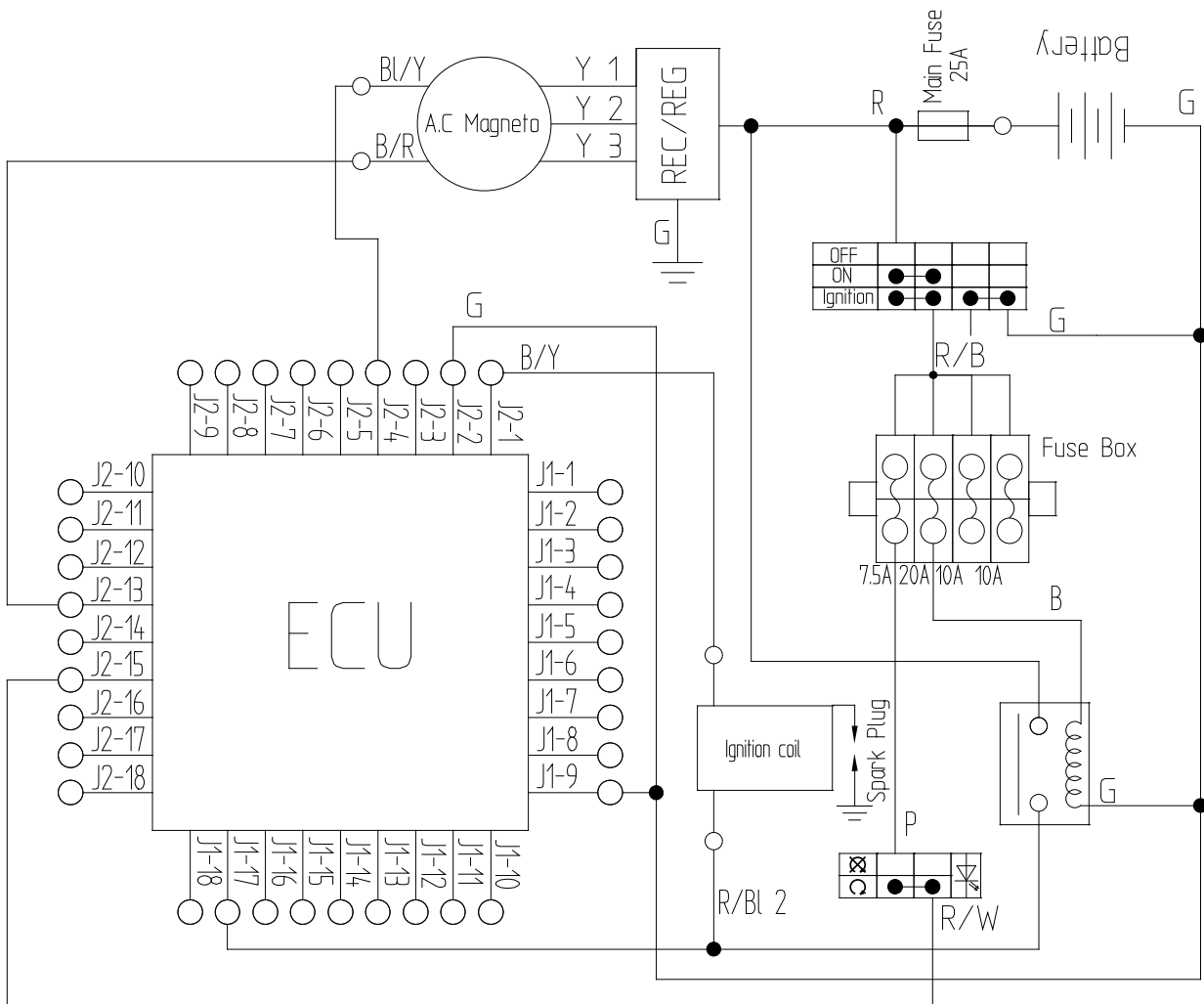

IF THE IGNITION SYSTEM FAILS TO OPERATE

Procedure

Check:

- | | |
|--|---|
| <ol style="list-style-type: none"> 1. Fuse (Main) 2. Battery 3. Spark plug 4. Ignition spark gap 5. Spark plug cap resistance 6. Ignition coil | <ol style="list-style-type: none"> 7. Main switch 8. Emergency stop switch 9. Wiring connection (entire ignition system) |
|--|---|

1. Fuse

INCONTINUITY



Check switches

Replace the fuse.

⇩ CONTINUITY

2. Battery

INCORRECT



- Check the battery condition.
Refer to "BATTERY TESTING"

- Clean battery terminals.
- Recharge or replace the battery.

⇩ CORRECT

3. Spark plug

OUT OF SPECIFICATION



- Check the spark plug condition.
- Check the spark plug type.
- Check the spark plug gap.

Repair or replace the spark plug



Spark plug gap: 0.8 ± 0.1 mm

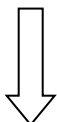

*

*



4. Ignition spark gap

- Disconnect the spark plug cap from the spark plug
- Connect the ignition tester 1 as shown.
- 2 Spark plug
- Turn the main switch to "ON".
- Check the ignition spark gap .
- Check the spark by pushing the starter switch, and increase the spark gap until a misfire occurs.

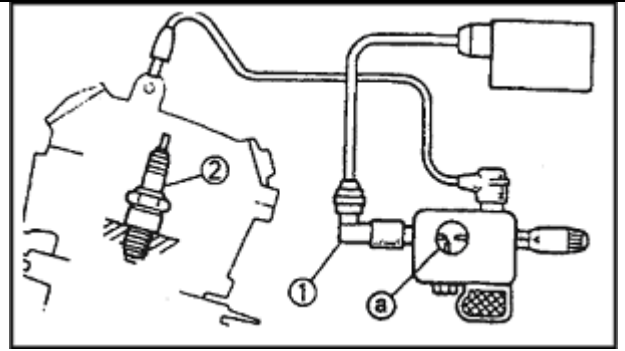

MEETS SPECIFICATION

The ignition system is not faulty.



**Minimum spark gap:
6mm (0.24 in)**

OUT OF
SPECIFICATION
OR
NO SPARK

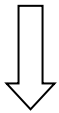

5. Spark plug cap resistance

- Remove the spark plug cap.
 - Connect the pocket tester ($\Omega \times 1k$) to the spark plug cap.
- NOTE:
- When removing the spark plug cap, do not pull the spark plug cap from high tension cord.
 - Remove → Turning counterclockwise
 - Connect → Turning clockwise.
 - Check the high tension cord when connecting the spark plug cap.
 - When connecting the spark plug cap, cut the high tension cord about 5mm.

Tester (+) lead →
Spark plug side ①
Tester (-) lead →
High tension cord side ②

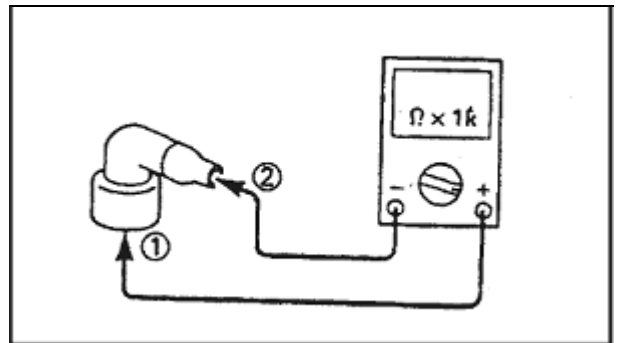

OUT OF SPECIFICATION

Replace the spark plug cap



**Spark plug cap
resistance:
5K Ω (20 °C)**



CORRECT

*



6. Ignition coil resistance

Disconnect the ignition coil connector from the wire harness.

- Connect the pocket tester (1) to the ignition coil.
- Check if the primary coil has the specified resistance.

Tester (+) lead
Pink Terminal
Tester (-) lead B/Y Terminal

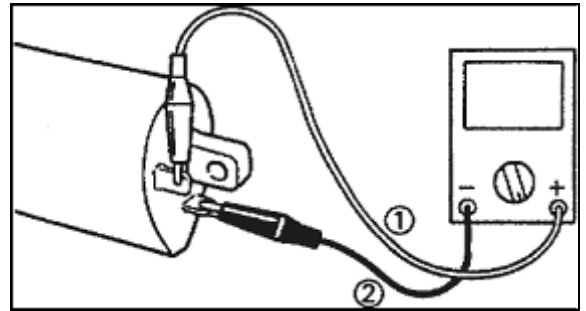

Primary coil resistance:
0.8Ω (20 °C)

- Connect the pocket tester to the ignition coil.
- Check the secondary has the specified resistance

Tester (+) lead
Spark plug lead
Tester (-) lead
Pink Terminal

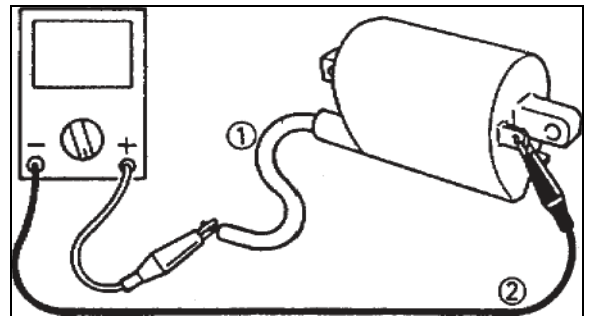

Secondary coil resistance:
6.8KΩ(20°C)

BOTH MEET SPECIFICATION

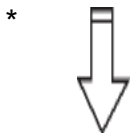

7. Main switch
CHECK SWITCHES

OUT OF SPECIFICATION

Replace the ignition coil.

NO CONTINUITY

Replace the main switch



CONTINIUTY

8. Emergency stop switch

CHECK SWITCHES



CONTINIUTY

NO CONTINIUTY



Replace the emergency stop switch

9. Wiring connection

● Check the connection of the entire ignition system

Refer to —CIRCUIT DIAGRAM II

POOR CONNECTIONS



Correct

CORRECT

Replace the igniter unit.

7.4 CHARGING SYSTEM

CHARGING SYSTEM CIRCUIT DIAGRAM

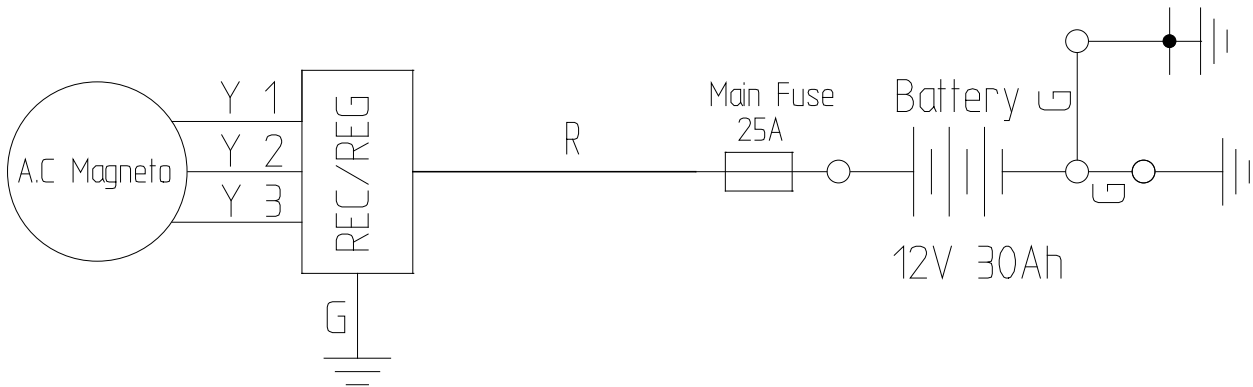

CURRENT DRAW - KEY OFF

CAUTION: Do not connect or disconnect the battery cable or ammeter with the engine running. Damage will occur to light bulbs and speed limiter. Connect an ammeter in series with the negative battery cable. Check for current draw with the key off, if the draw is excessive, loads should be disconnected from the system one by one until the draw is eliminated. Check component wiring as well as the component for partial shorts to ground to eliminate the draw.

| |
|---------------------------------|
| Current draw key off: |
| Maximum of 0.01DCA(10mA) |

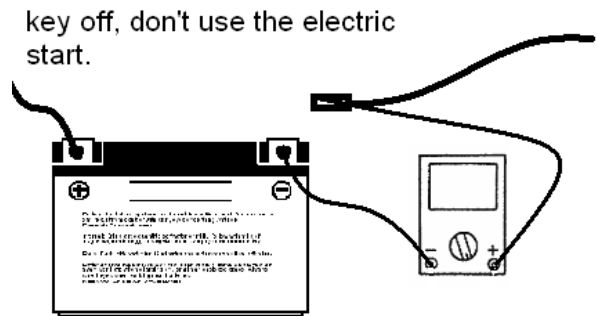

CHARGING SYSTEM

Procedure

Check:

1. Fuse (Main)
2. Battery
3. Charging voltage
4. Stator coil resistance
5. Wiring system (entire charging system)

1. fuse

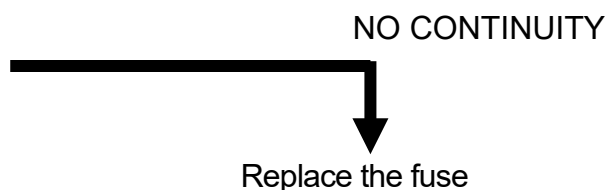

2. Battery

Check the battery condition.
Refer to "BATTERY INSPECTION"

INCORRECT



Clean battery terminals
Recharge or replace the battery

3. Charging voltage

Connect the engine tachometer to the spark plug lead.

●Connect the pocket tester (DC20V) to the battery

Test (+) lead →

Battery (+) terminal ①

Test (-) lead →

Battery (-) terminal ②

Measure the battery terminal voltage.

start the engine and accelerate to about 5,000rpm

●check the terminal voltage

Measured voltage-terminal

Voltage:

0.2-2.5V up

NOTE: Use a fully charged battery.

OUT OF SPECIFICATION



The charging circuit is not faulty
Replace the battery

MEETS SPECIFICATION



4. Starter coil resistance

Remove the A.C. magneto coupler from wire harness

Connect the pocket tester (ΩX1) to the stator coil

Tester (+) lead –yellow terminal

Tester (-) lead –yellow terminal

Measure the stator coil resistance

Stator coil resistance 0.5-0.8Ω (20°C)

OUT OF SPECIFICATION



Replace the stator coil

MEETS SPECIFICATION



5. Wiring connection
check the entire charging system for
connections
Refer to "CIRCUIT DIAGRAM"

POOR CONNECTION



correct

CORRECT



Replace the rectifier/regulator

**7.5 ELECTRICS STARTING SYSTEM
DIAGRAM**

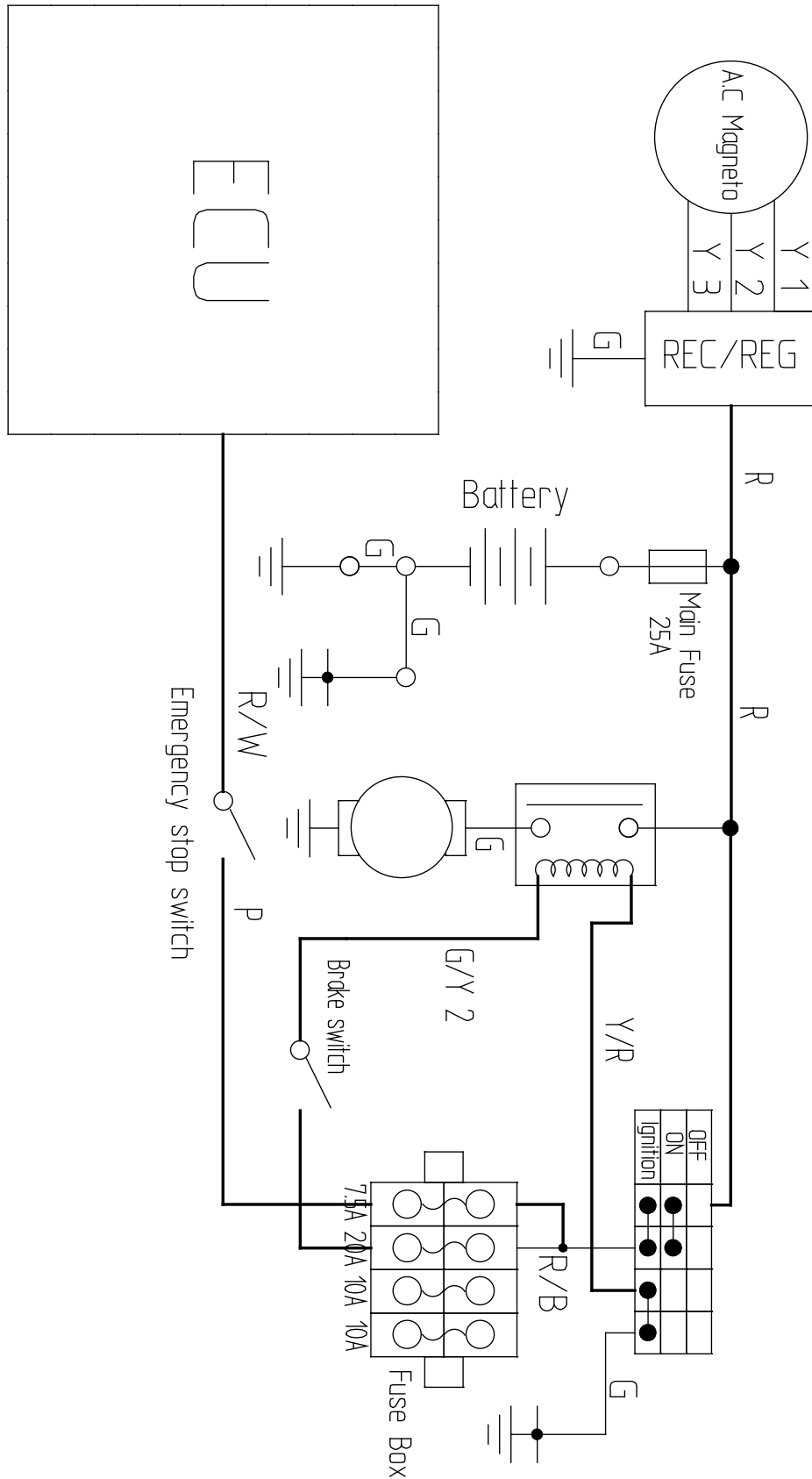

TROUBLESHOOTING

IF THE STARTER MOTOR FAILS TO OPERATE

Procedure

Check:

- | | |
|--|---|
| <ol style="list-style-type: none"> 1. Fuse (Main) 2. Battery 3. starter motor 4. starter relay 5. main switch | <ol style="list-style-type: none"> 6. Engine stop switch 7. front/rear brake switch 8. Starter switch 9. wiring connection (entire starting system) |
|--|---|

1. fuse
refer to "CHECKING SWITCHES" section



NO CONTINUITY



Replace the fuse

2. Battery
Check the battery condition.
Refer to "BATTERY INSPECTION" section in CHAPTER 3



INCORRECT



Clean battery terminals
Recharge or replace the battery

3. Starter motor
Connect the battery positive terminal and starter motor cable using a jumper lead.
Check the starter motor operation

DOES NOT MOVE



Repair or replace the starter motor

4. Starter relay

- Disconnect the relay unit coupler from the wire harness.
- Connect the pocket tester ($\Omega \times 1$) and battery (12V) to the relay unit coupler terminals.

Battery (+) lead →
Green/Yellow terminal ①
Battery (-) lead →
Yellow/Red terminal ②

- Check the starter relay for continuity.

Test (+) lead → ③ terminal
Test (-) lead → ④ terminal

WARNING

A wire used as a jumper lead must have the equivalent capacity as that of the battery lead or more, otherwise it may burn.

This check is likely to produce sparks, so be sure that no flammable gas or fluid is in the vicinity

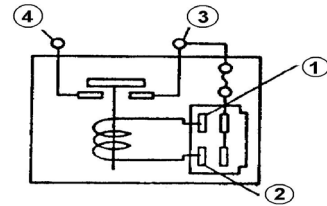

CONTINUITY



Replace the starter replay

5. Main switch
CHECK SWITCHES



NO CONTINUITY

Replace the main switch

6. Emergency stop switch



NO CONTINUITY

Replace emergency stop switch

7. Front /rear brake switch

CHECKING SWITCHES

NO CONTINUITY

Replace the brake switch

8. Starter switch

CHECKING SWITCHES



NO CONTINUITY



Replace the handlebar switch

9. Wiring connection

Check the connections of the entire starting system.

Refer to "CIRCUIT DIAGRAM

POOR CONNECTION



Correct

7.6 COOLING SYSTEM

IF THE FAN MOTOR FAILS TO TURN

Procedure

Check:

- | | |
|---|---|
| <ol style="list-style-type: none"> 1. Fuse (Main, Fan) 2. Battery 3. Main switch | <ol style="list-style-type: none"> 4. Fan motor (inspection) 5. Thermo switch 6. Relay 7. Wiring connection (entire cooling system) |
|---|---|

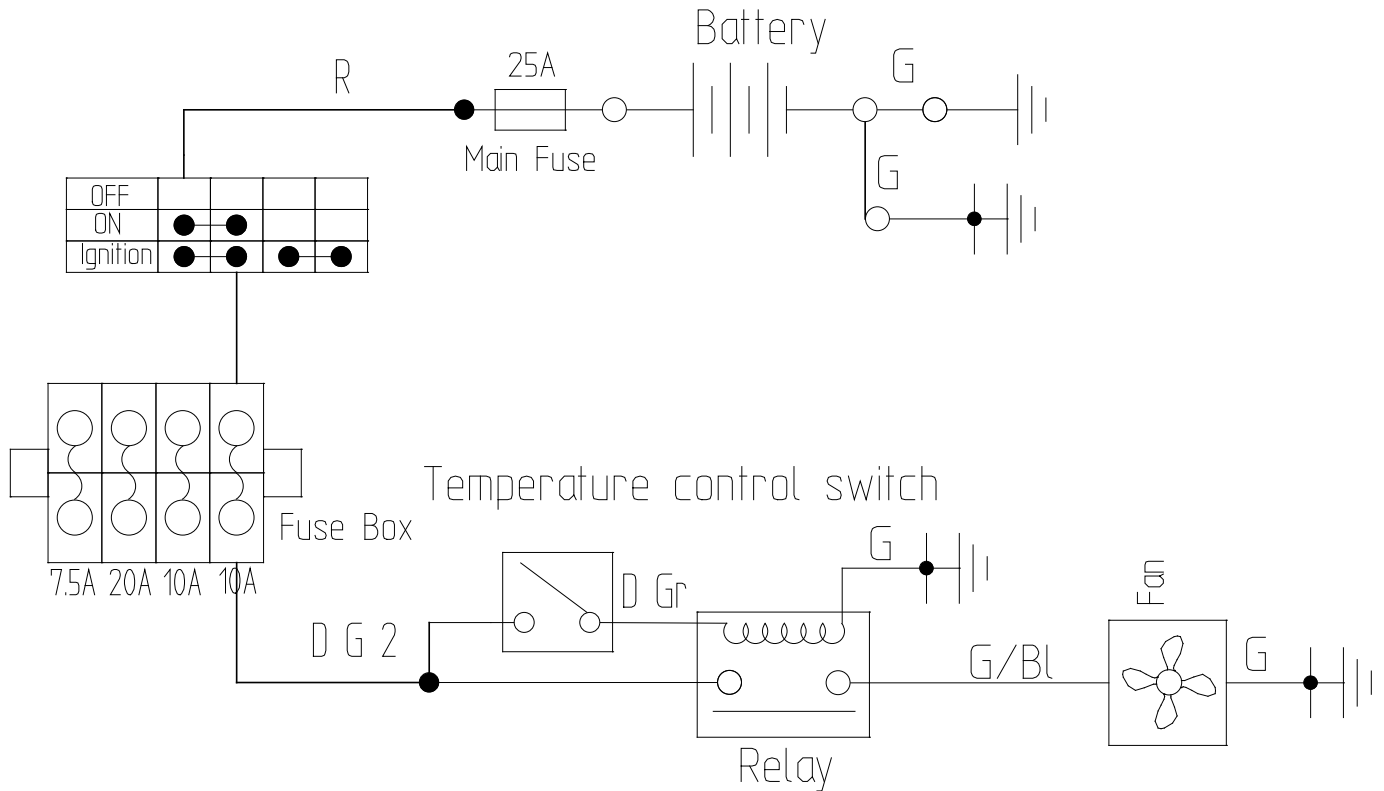

1. fuse
CHECK SWITCHES



2. Battery
Check the battery condition.
Refer to "BATTERY INSPECTION" section



NO CONTINUITY



Replace the fuse

INCORRECT



Clean battery terminals
Recharge or replace the battery

3 Main switch
CHECK SWITCHES

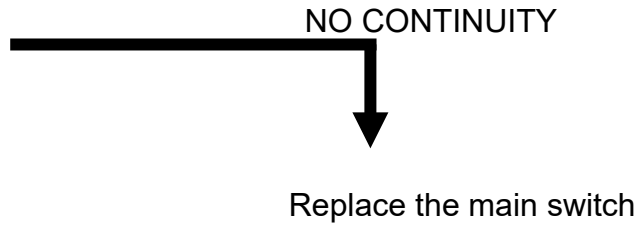

4. Fan motor(inspection 1)
Connect the battery to the fan motor.
Battery (+) lead→**Green/Blue terminal**
①
Battery (-) lead→**Green ground** ②
Check the fan motor operation

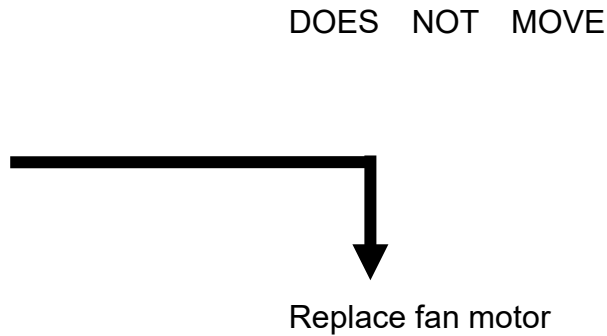

5. Fan motor (inspection 2)
Turn the main switch to off.
●Remove the thermo switch lead from thermo switch.
●Connect jumper lead to thermo switch leads.
●Turn the main switch to on

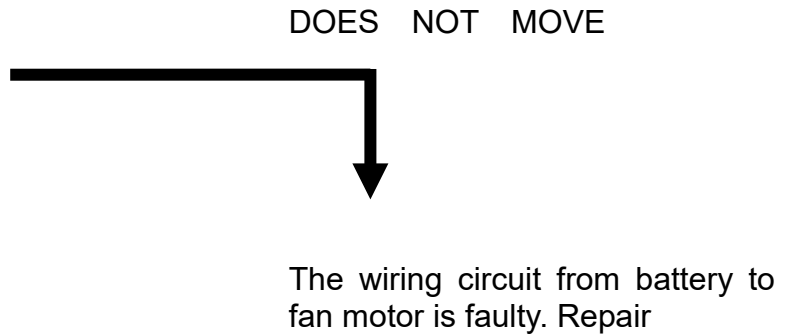

6. Thermo switch
Remove the thermo switch from the radiator.
●Connect the pocket tester (ΩX1) to the thermo switch①.
●Immerse the thermo switch in the water ②
●Check the thermo switch for continuity.
NOTE:
Measure temperatures while heating the coolant with the temperature gauge

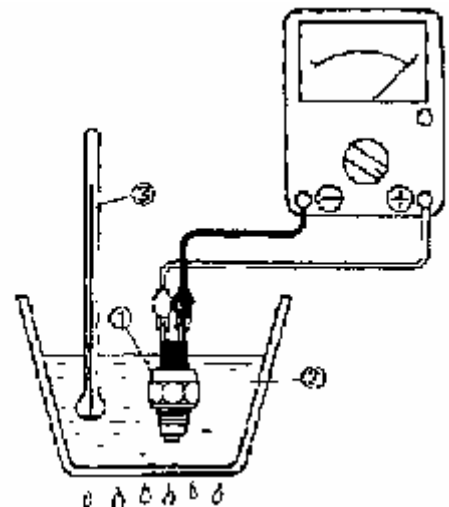

7. Starter relay

- Disconnect the relay unit coupler from the wire harness.
- Connect the pocket tester ($\Omega \times 1$) and battery (12V) to the relay unit coupler terminals.

Battery (+) lead →
Dark Gray terminal ①
Battery (-) lead →
Green terminal ②

- Check the relay for continuity.
- Test (+) lead → ③ terminal
- Test (-) lead → ④ terminal



8. Wiring connection
- Check the connection of the entire cooling system.
 - Refer to "CIRCUIT DIAGRAM"

WARNING

A wire used as a jumper lead must have the equivalent capacity as that of the battery lead or more, otherwise it may burn.

This check is likely to produce sparks, so be sure that no flammable gas or fluid is in the vicinity.

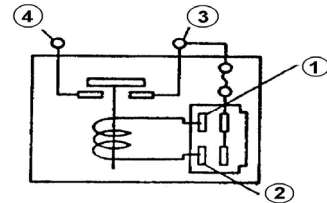

Replace the relay



UPPER CONNECTION

Correct

IF THE HEAT ALARM UNIT WORKING

When the main switch is turned on, the temperature of the engine begins to go up. As it comes to 75±3°C the thermostat is connected and the fan starts to work, cooling the coolant, if the thermostat or the fan, fails to work; the coolant temperature will keep rising. The heat alarm unit operates the moment the temperature reaches 115°C with the buzzer sounding and the signal flashing. Stop the engine now to have the circuit fixed.

Procedure

Check:

- | | |
|--------------------|--|
| 1. Fuse(Main, Fan) | 4. Thermo unit |
| 2. Battery | 5. Voltage |
| 3. Main switch | 6. Relay |
| | 7. Wiring connection (entire cooling system) |

1. fuse

CHECKING SWITCHES



2. Battery

Check the battery condition.
Refer to "BATTERY INSPECTION"



3. Main switch

CHECKING SWITCHES



NO CONTINUITY



Replace the fuse

INCORRECT



Clean battery terminals
Recharge or replace the battery

NO CONTINUITY



Replace the main switch

4. Thermo unit

- Drain the coolant and remove the thermo unit from the cylinder head.
- Immerse the thermo unit ② in the coolant ③ .
- ① Thermometer.

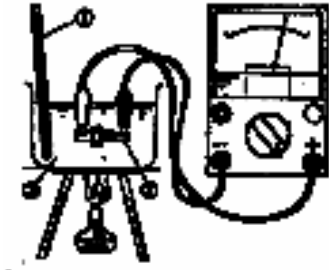

| Coolant temperature | Resistance |
|---------------------|------------|
| 80°C | 47.5~56.8Ω |
| 100°C | 26.2~29.3Ω |

Handle the thermo unit with special care. Never subject it to strong shocks or allow it to be dropped. Should it be dropped, it must be replaced. Do not touch the thermo unit to the bottom of the heated vessel.

OUT OF SPECIFICATION



Replace the thermo unit

MEETS SPECIFICATION



5. Voltage

- Connect the pocket tester (DC20V) to the Temperature gauge couple.
- Tester (+) lead → Green/Blue terminal**
- Tester (-) lead → Green ground**
- Turn the main switch to on.
- Check for voltage (12V) on the temperature gauge lead.

OUT OF SPECIFICATION



The wiring circuit from main switch to temperature gauge is faulty. Repair.



6. Relay

Measure the relay.

NOT CONDUCTION



Replace the relay



7. Wiring connection check the connections of the entire cooling system.
Refer to "CIRCUIT DIAGRAM"



Replace the temperature gauge

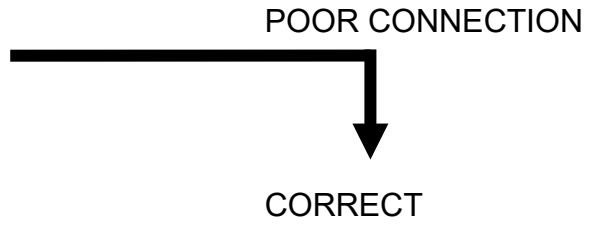

**7.7 LIGHTING SYSTEM
FOR USA MODEL**

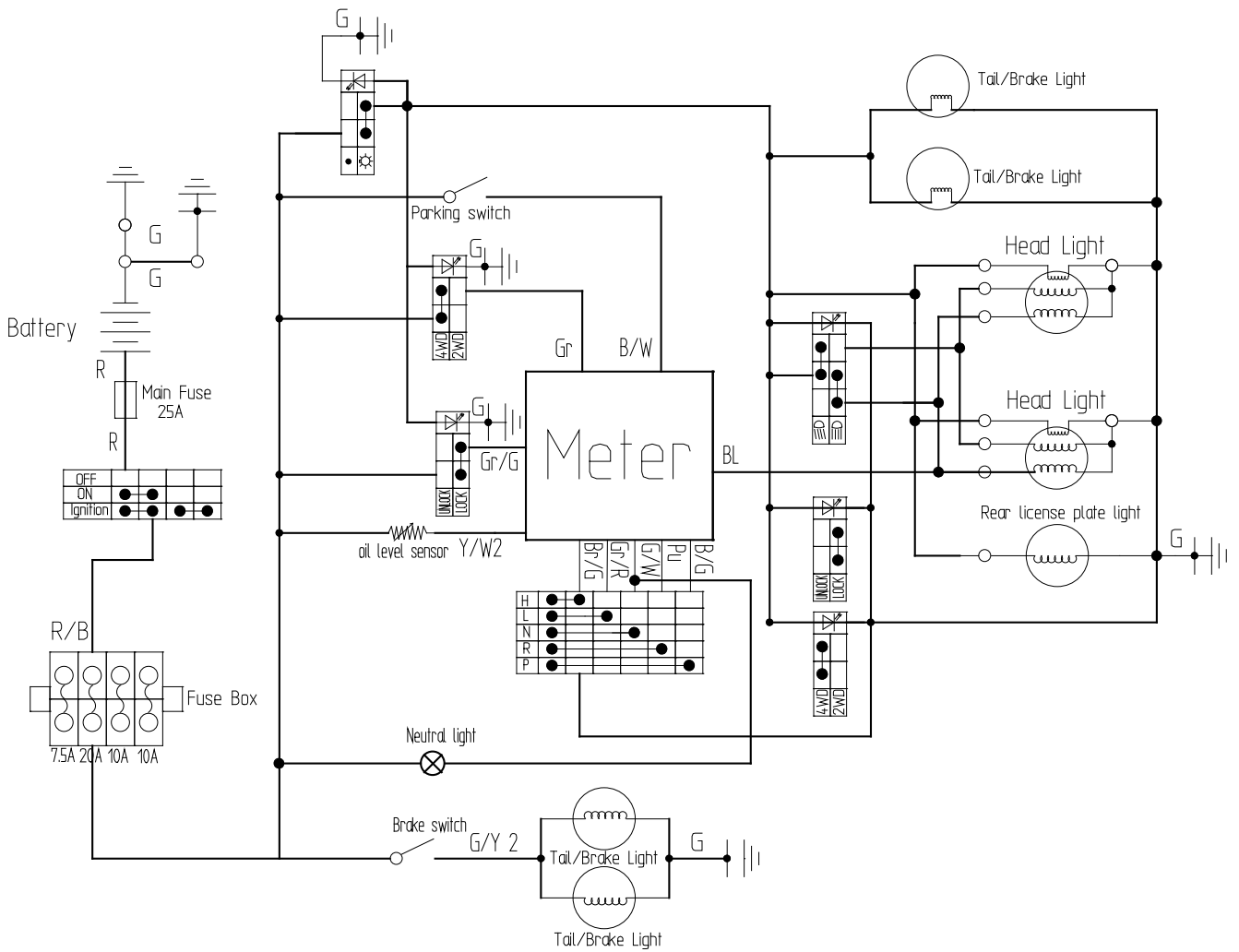

FOR EUROPE MODEL

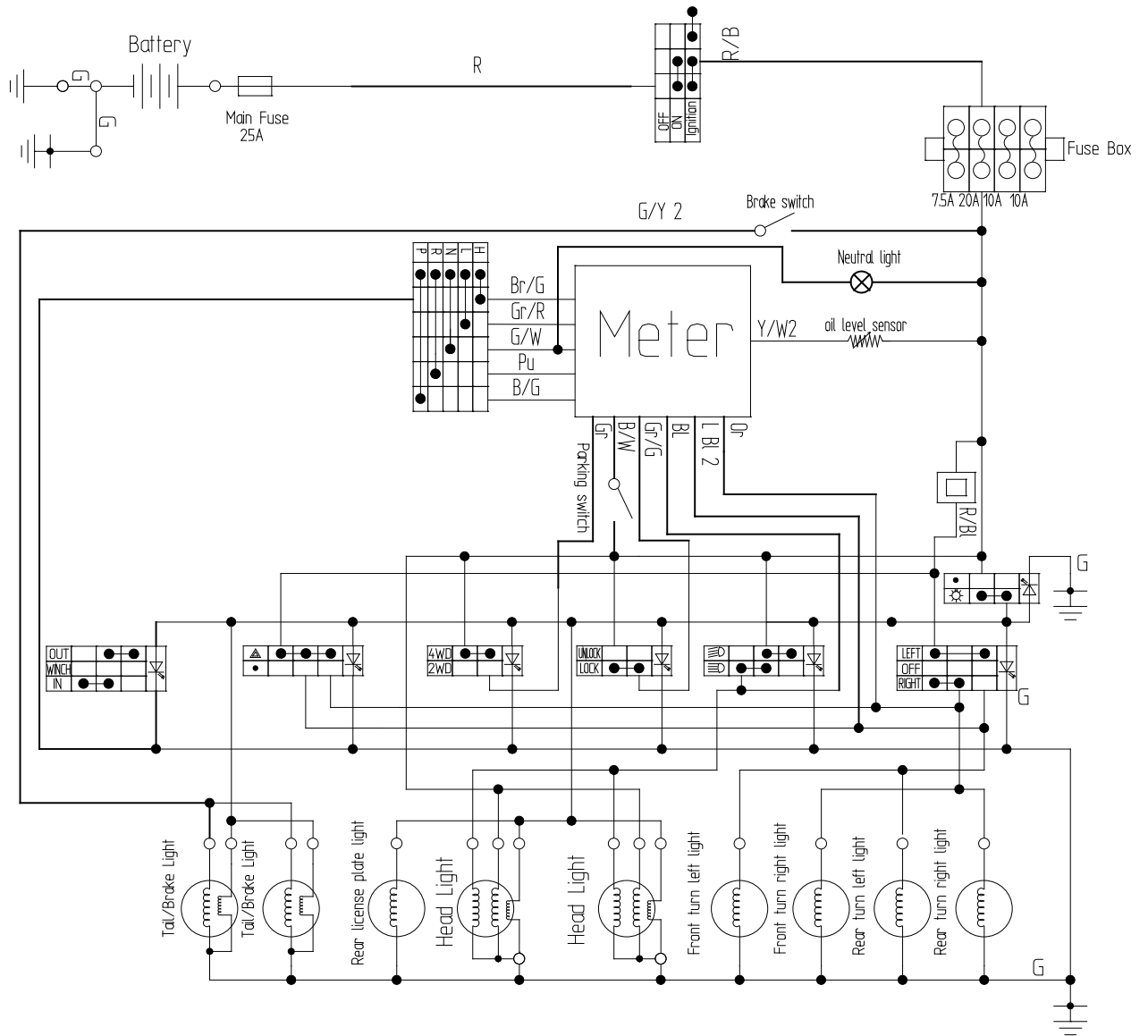

TROUBLESHOOTING
Procedure

Check:

- 1. Fuse (Main)
- 2. Battery
- 3. Main switch
- 4. Lights switch
- 5. Distance light switch
- 6. Wiring connection (entire lighting system)

1. fuse refer to "CHECKING SWITCHES" section



NO CONTINUITY



Replace the fuse

2. Battery Check the battery condition. Refer to "BATTERY INSPECTION" section in CHAPTER 3



INCORRECT



Clean battery terminals
Recharge or replace the battery

3. Main switch CHECK SWITCHES



NO CONTINUITY



Replace the main switch

4. Light switch CHECK SWITCHES

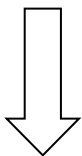

NO CONTINUITY



Replace the light switch

5. Distance light switch CHECK SWITCHES

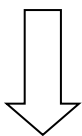

NO CONTINUITY



Replace the distance light switch

6. Wiring connection Check the connection of the entire

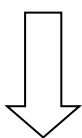

POOR CONNECTIONS



lighting system

correct

7.check the condition of each of the lighting system's circuits

Refer to "LIGHTING SYSTEM CHECK"

LIGHT SYSTEM CHECK

1. If the headlight and the high beam indicator light fail to come on

1. Bulb and bulb socket

CHECK SWITCHES



2. Voltage

Connect the pocket tester (DC20V) to the headlight and high beam indicator light couplers.

A When the dimmer switch is on low beam.

B When dimmer switch is on high beam

Headlight::

Tester (+) lead → White ① or Blue ② lead

Tester negative (-) lead → Green ③ lead

Turn the main switch to on.

Turn the light switch to on position.

Turn the dimmer switch to low beam or high beam.

Check for voltage (12V) on the lead at bulb socket connectors

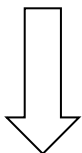

This circuit is not faulty

NO CONTINUITY



Replace the bulb and/ or bulb socket

OUT OF SPECIFICATION



The wiring circuit from the main switch to bulb socket connector is faulty. Repair

2. the taillight fails to come on

1. Bulb and bulb socket

CHECK SWITCHES

NO CONTINUITY



Replace the bulb and /or bulb socket

CONTINUITY

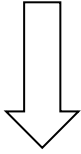

2. Voltage

Connect the pocket tester (DC20V) to the bulb socket connector.

Tester (+) lead→

Brown terminal ①

Tester (-) lead→

Green terminal ②

Turn the main switch to on.

Turn the lights switch to on pilot position.

Check the voltage (12V) on the bulb socket connector

OUT OF SPECIFICATION



The wiring circuit from main switch to bulb connector of faulty.

Repair

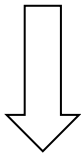

This circuit is not faulty

7.8 REVERSE LIMIT SYSTEM

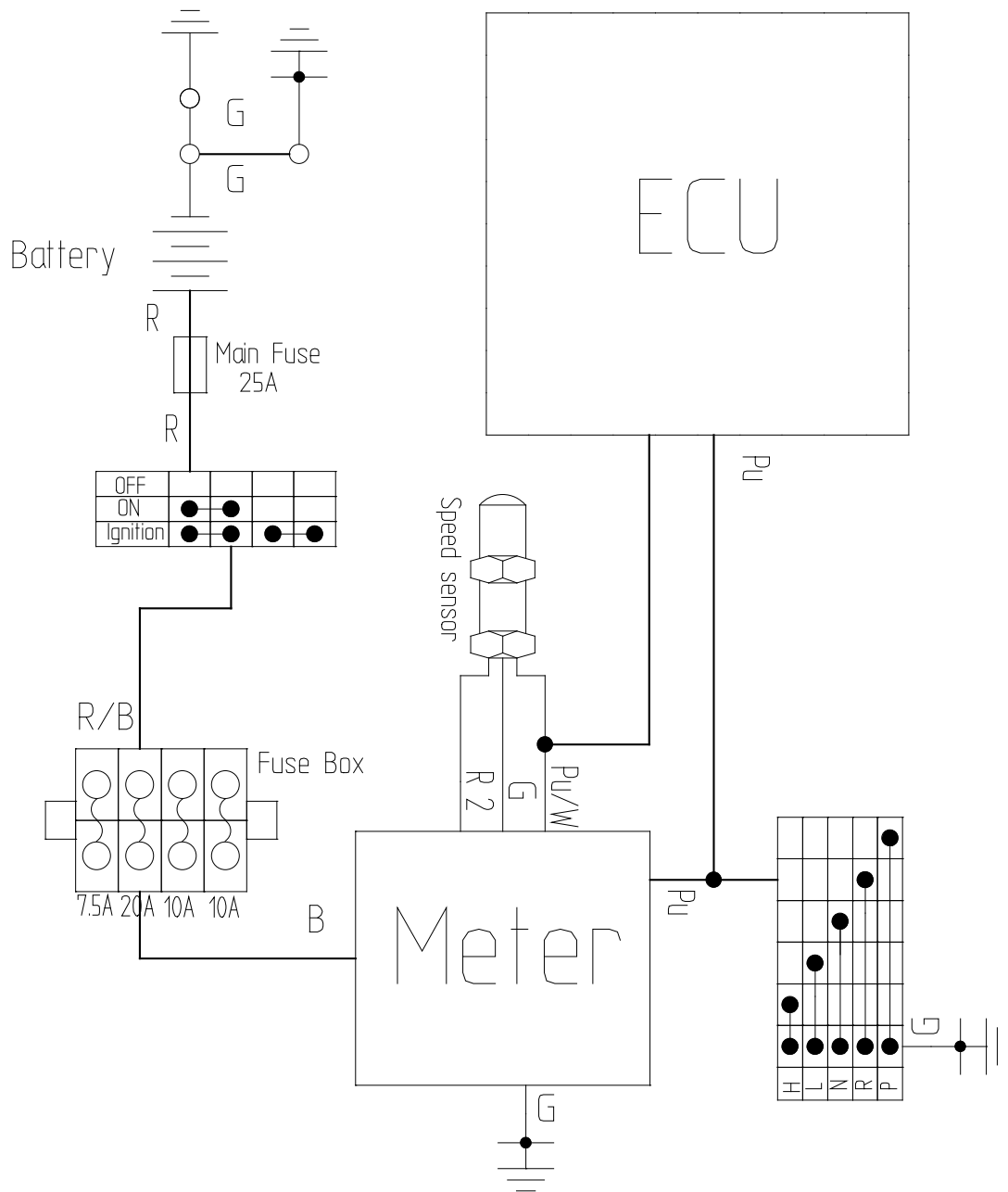

The default setting for ECU reverse speed limit is 15km/h.





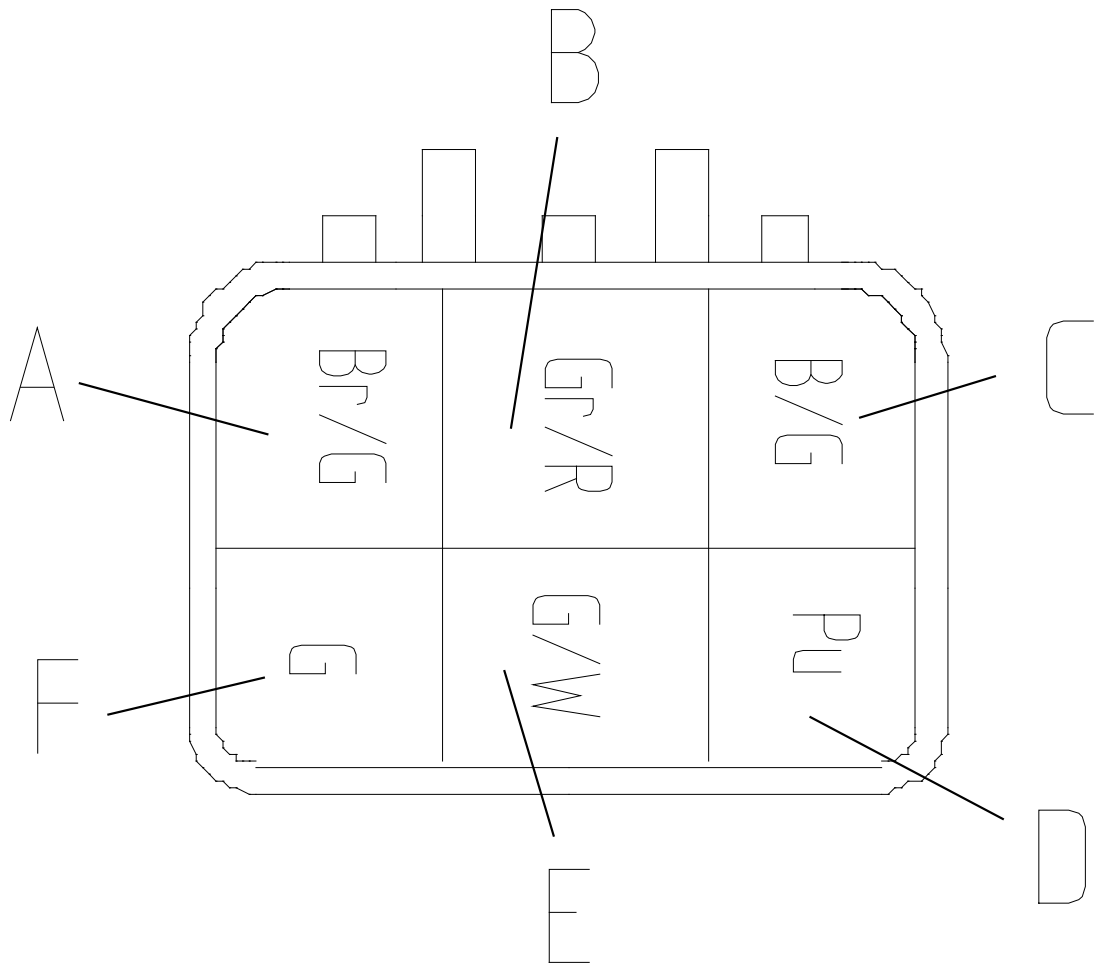

7.9 GEAR POSITION INDICATOR SWITCH TEST

Switch table



High Range
 Low Range
 Neutral
 Reverse
 Parking

| | F | A | B | E | D | C |
|------------|---|---|---|---|---|---|
| High Range | ● | ● | | | | |
| Low Range | ● | | ● | | | |
| Neutral | ● | | | ● | | |
| Reverse | ● | | | | ● | |
| Parking | ● | | | | | ● |

| | | | |
|--|--|--|--|
| <p>Low range The LCD screen show “L” below the middle position.</p> | |  | |
| <p>High range The LCD screen show “H” below the middle position.</p> | |  | |
| <p>Neutral The LCD screen show “N” below the middle position. Neutral light is lit.</p> | |  | |
| <p>Reverse The LCD screen show “R” below the middle position.</p> | |  | |
| <p>Parking The LCD screen show “P” below the middle position.</p> | |  | |

Switch schematic

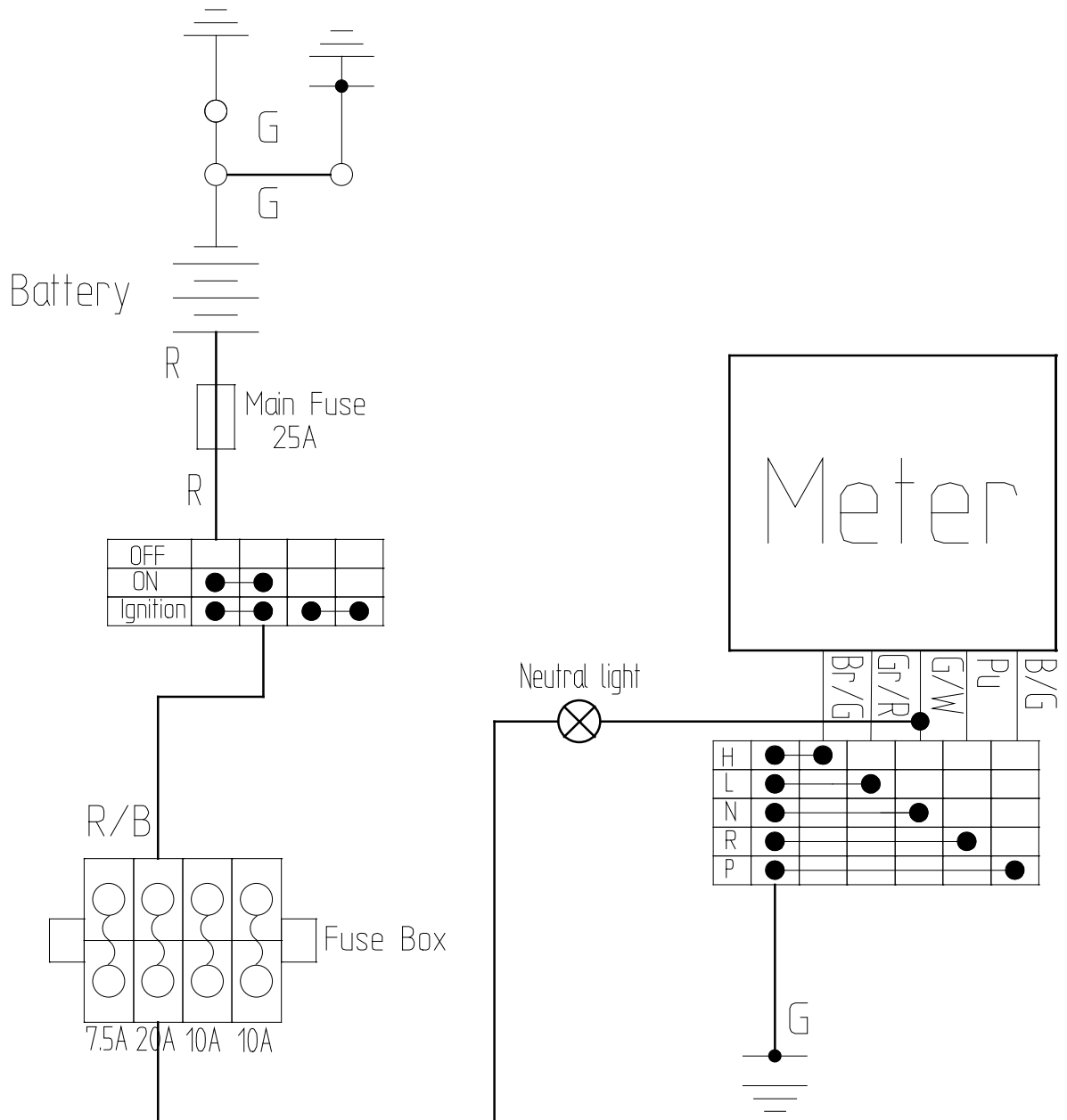

7.10 SPEEDMETER SYSTEM

OPERATION OF SPPEED SENSOR

Speed Sensor is on the rear axle

Operation Instructions of Electric Dial Meter and Speed Sensor/ Operation Instructions of LCD Meter and Speed Sensor

A. Hall Sensor is a new type sensor used to measure speed, angle, revolution and length, etc by means of voltage pulse signals converted from sensing gear ratio of black metal gear or gear rack.

B. Main Technical Parameter for sensor:

| Item | Code | Vol value | Unit |
|----------------------|------|-----------------|------|
| Operating voltage | Vcc | 5-20 | V |
| Operating current | Icc | ≤15 | mA |
| Low voltage output | Vol | ≤ 0.4 | V |
| Hight voltage output | Voh | ≥ (Vcc-1) | V |
| Operating distance | D | 1mm ≤ D ≤ 2.5mm | mm |

C. The following is the graphic illustration for sensor installation, Wire 1 (red) is positive and wire 2 (black) negative, Wire 3 (yellow) works as the one to output signals.

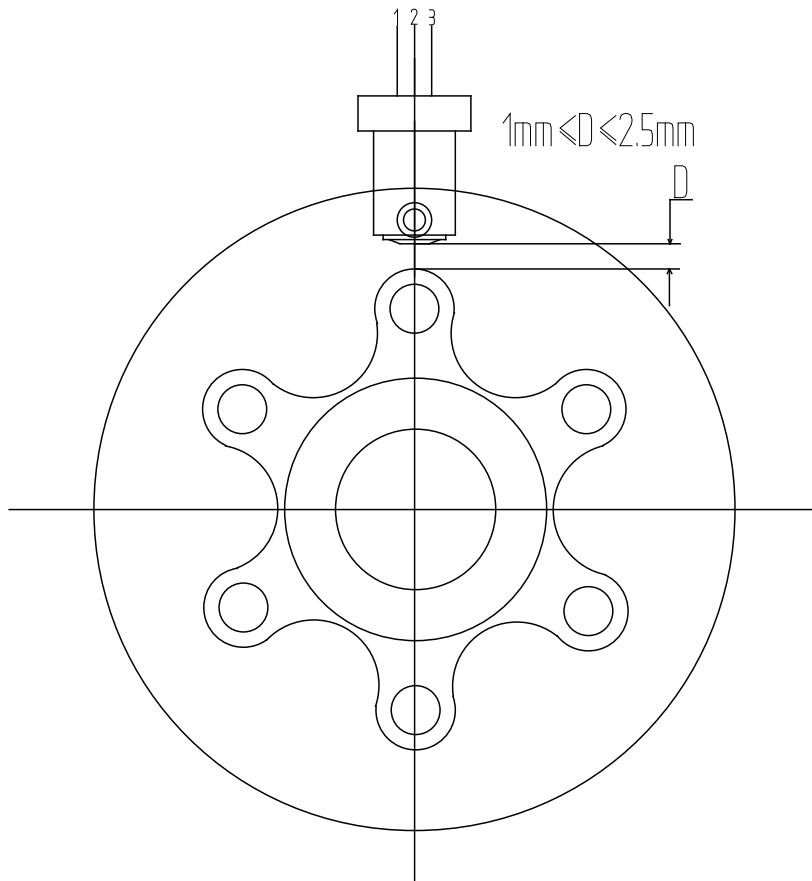

Note: Always screw in the sensor by hand when installation or adjustment.

1. Align one tooth of the splines to the centre of the hole of the sensor by turning the rear axle.
2. Screw the sensor in (CW) by hand slightly until resistance is felt.
3. Turn the sensor CCW by 1 to 2 turn(s).
4. Tighten the jam nut.

Operation Instructions of the Meter assembly

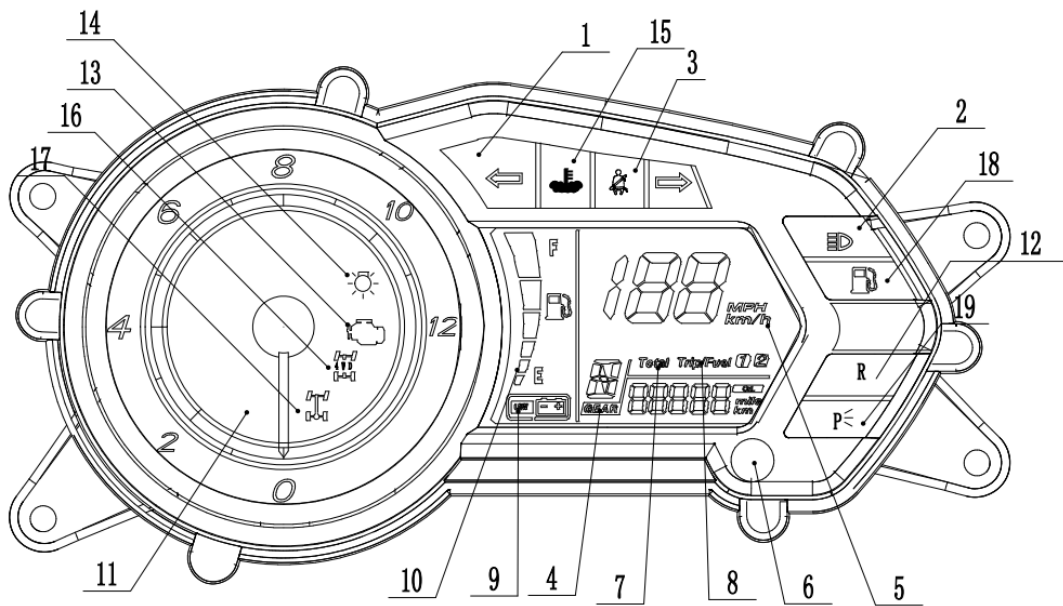

- | | |
|---|---------------------------------|
| 1. Left turn signal lamp | 7. The odometer |
| 2. High beam indicator light | 8. Trip/ Total selector |
| 3. Safe belt indicator | 9. Battery alarm indicator |
| 4. LCD show | 10. Oil position show |
| 5. Km/h/ mile/h selector | 11. Engine rpm meter |
| 6. Fuction button | 12. Reverse indicator light |
| 13. Electric fuel injection failure alarm indicator | 16. 4WD indicator |
| 14. Lamp switch indicator | 17. Differential lock indicator |
| 15. Water temperature alarm indicator | |

7.11 MAIN SWITCH AND HANDLE SWITCH

| | R | R/B | G | R/Y |
|-------|-----|-----|-----|-----|
| OFF | | | | |
| ON | ○—○ | | | |
| START | ○—○ | ○—○ | ○—○ | |

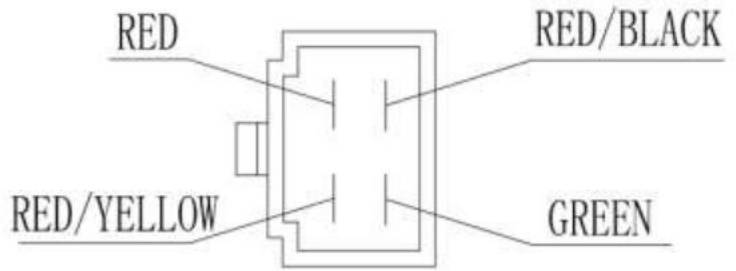

DJ70413-6. 3-11



7.12 FUEL GAUGE/ FUEL LEVEL SENSOR

Removal

Turn the ignition switch to “OFF” .
 Remove two connecting pipe of oil pump.
 Remove the terminal of oil pump.
 Remove the oil pump cover.
 Retain plate and fuel level sensor from the fuel tank.

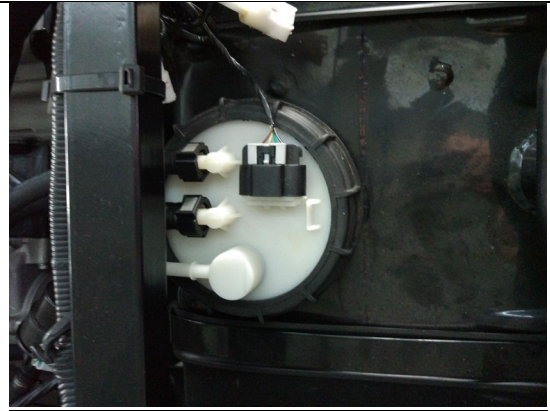

Installation

Install rubber oil seal to the oil pump.
 Install oil pump to the fuel tank, location to align .
 Install the oil pump cover.
 Install two connecting pipe of oil pump.
 Install the terminal of oil pump.



Fuel Gauge / Fuel level Sensor Inspection

Move the float to the bottom (RESERVE) position, turn the ignition switch to “ON” and check the fuel gauge.

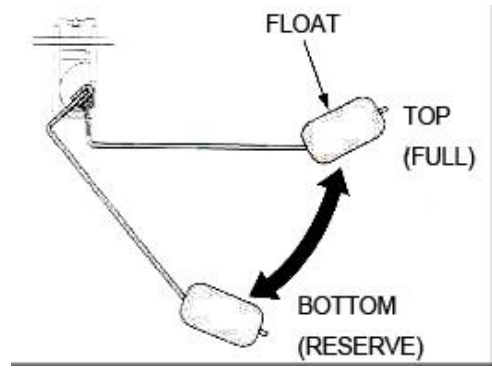

When shows that there are only two segments, segments should blink.

With the fuel level sensor float at the top (FULL) position, turn the main switch to "ON" and check the fuel gauge. All segments up to segment "F" should come on.

If all of the six segments blink, check the wiring connection of fuel level system. Refer to "Circuit of the fuel level"

If the fuel gauge does not function properly, check the fuel level sensor
 If the fuel level sensor is OK, replace the LCD Meter.

Fuel level Sensor Inspection

Disconnect the fuel level sensor 2p Green connector and connect the ohmmeter to the sensor side connector terminals. Measure the fuel level sensor resistance with the float at the top (FULL) And bottom (RESERVE) positions.

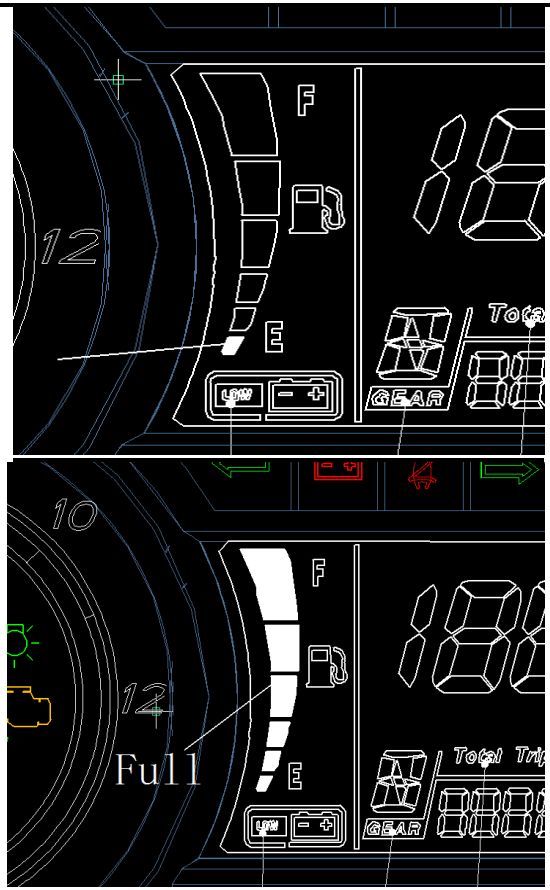

| FLOAT POSITION | RESISTANCE(20°C/ 68° F) |
|-----------------|----------------------------|
| TOP(FULL) | 0-12 Ω (±2 Ω) |
| BOTTOM(RESERVE) | 94-128 Ω (±2 Ω) |

8.13 WIRING DIAGR

WIRING DIAGRAM FOR XY450U-A UTV EURDPE MODEL

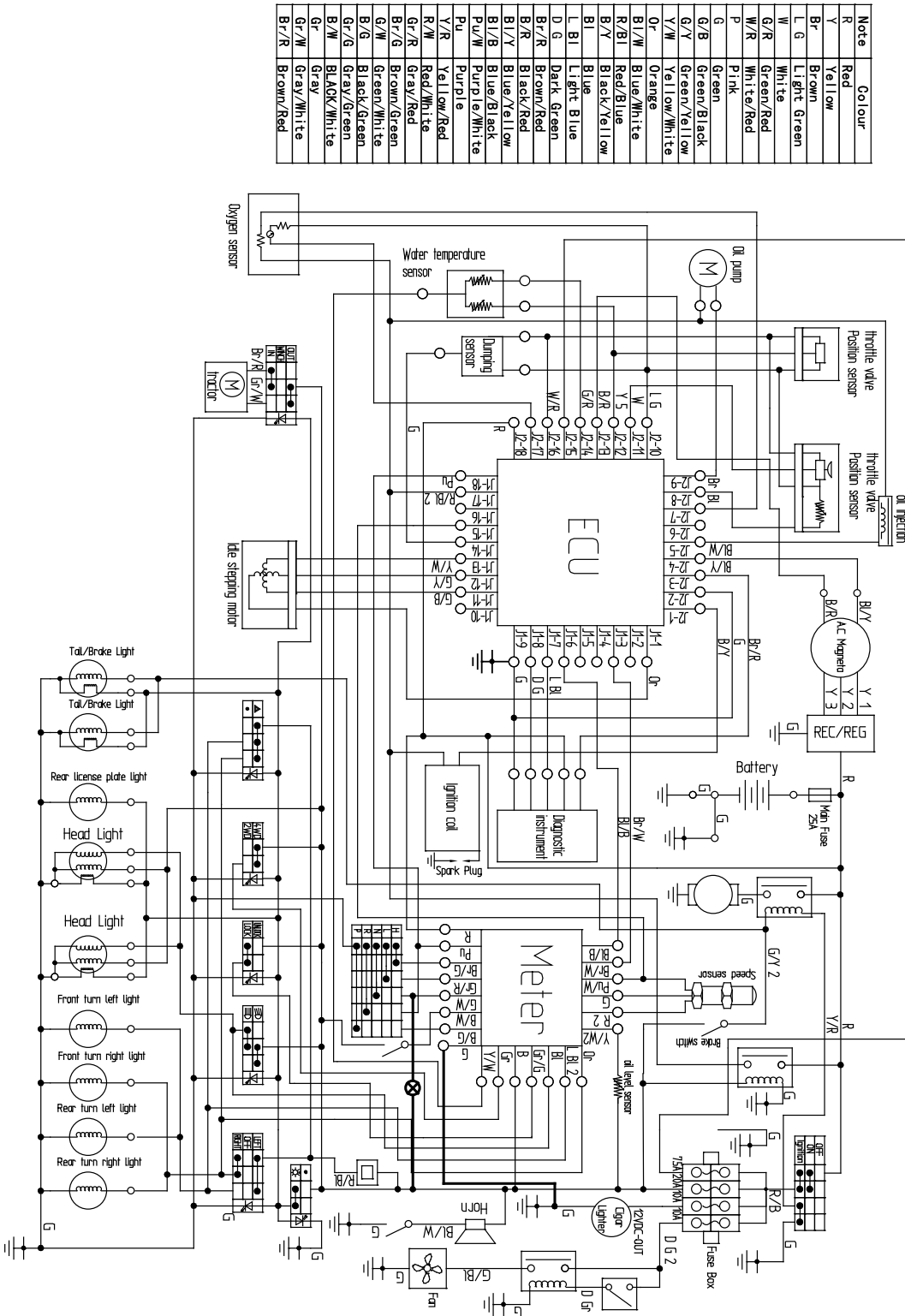

WIRING DIAGRAM FOR XV450U-A UTV U.S.A MODEL

| | |
|------|--------------|
| Note | Color |
| R | Red |
| Y | Yellow |
| Br | Brown |
| L G | Light Green |
| W | White |
| G/R | Green/Red |
| W/R | White/Red |
| P | Pink |
| G | Green |
| G/B | Green/Black |
| G/Y | Green/Yellow |
| Y/W | Yellow/White |
| Or | Orange |
| B1/W | Blue/White |
| R/B1 | Red/Blue |
| B/Y | Black/Yellow |
| B1 | Blue |
| L B1 | Light Blue |
| D G | Dark Green |
| Br/R | Brown/Red |
| B/R | Black/Red |
| B1/Y | Blue/Yellow |
| B1/B | Blue/Black |
| Pu/W | Purple/White |
| Pu | Purple |
| Y/R | Yellow/Red |
| R/W | Red/White |
| Gr/R | Gray/Red |
| Br/G | Brown/Green |
| G/W | Green/White |
| B/G | Black/Green |
| Gr/G | Gray/Green |
| B/W | Black/White |
| Gr | Gray |
| Gr/W | Gray/White |
| Br/R | Brown/Red |

