



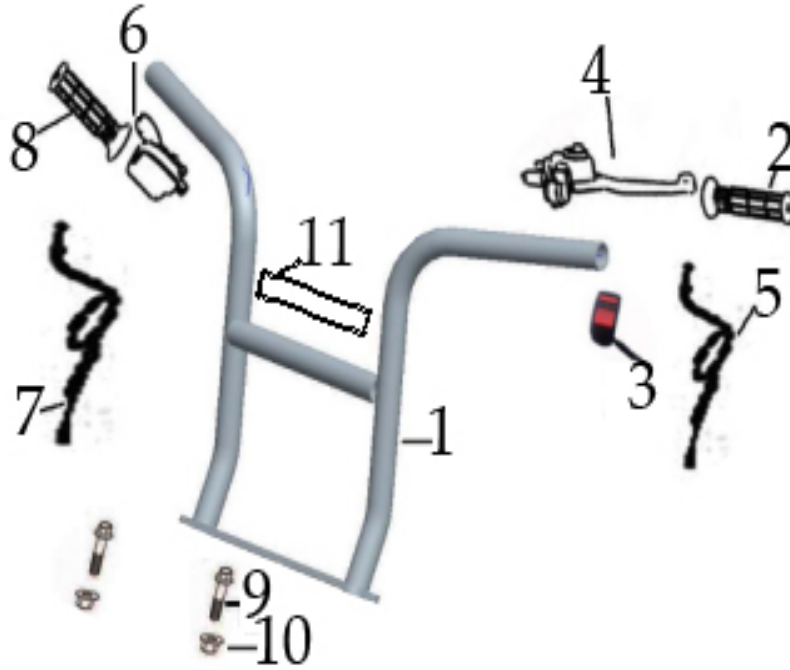
# MINI BIKE-STORM 200

VERSION 1.0

## 2020-11

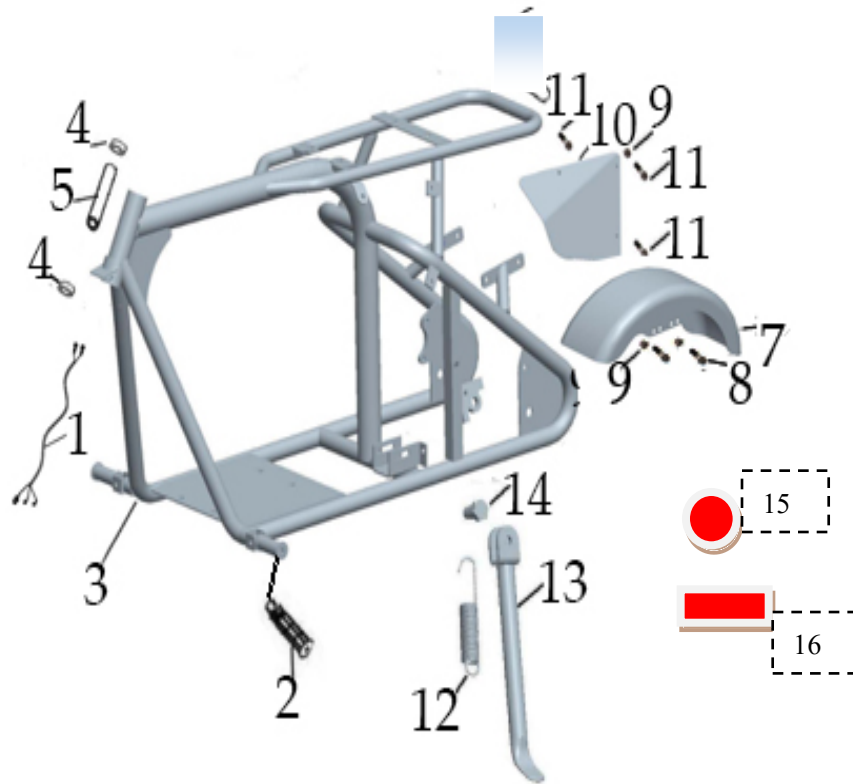


**FIG. 1 HANDLEBAR GROUP**



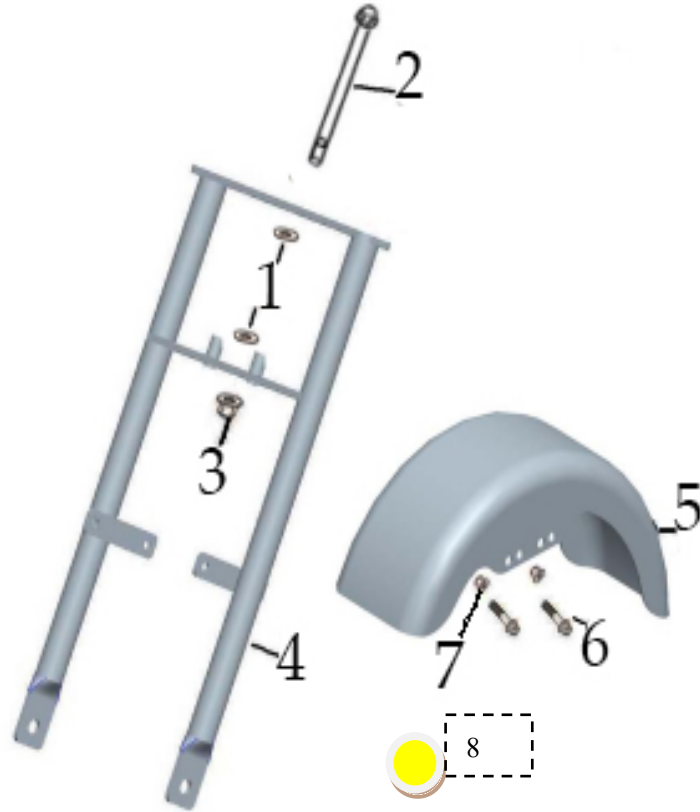
NO.	CODE	DESCRIPTION	QTY.
1	60200-XL	HANDLEBAR.COMP	1
2	58193-N	GRIP L.	1
3	40600-L	ENGINE STOP BUTTON	1
4	40090-L	BRAKE LEVER	1
5	40270-50XL	BRAKE CABLE	1
6	40510-L	THROTTLE BRAK CET COMP.	1
7	60120-XL	THROTTLE CABLE COMP.	1
8	40520-L	GRIP R.	1
9	57891002512505	GB5789 BOLT M10*1.25*25	2
10	61871000012505	GB6187 NUT M10*1.25	2
11	65010-XL	HANDLEBAR FOAM PADDING	1

**FIG. 2 FRAME COMP**



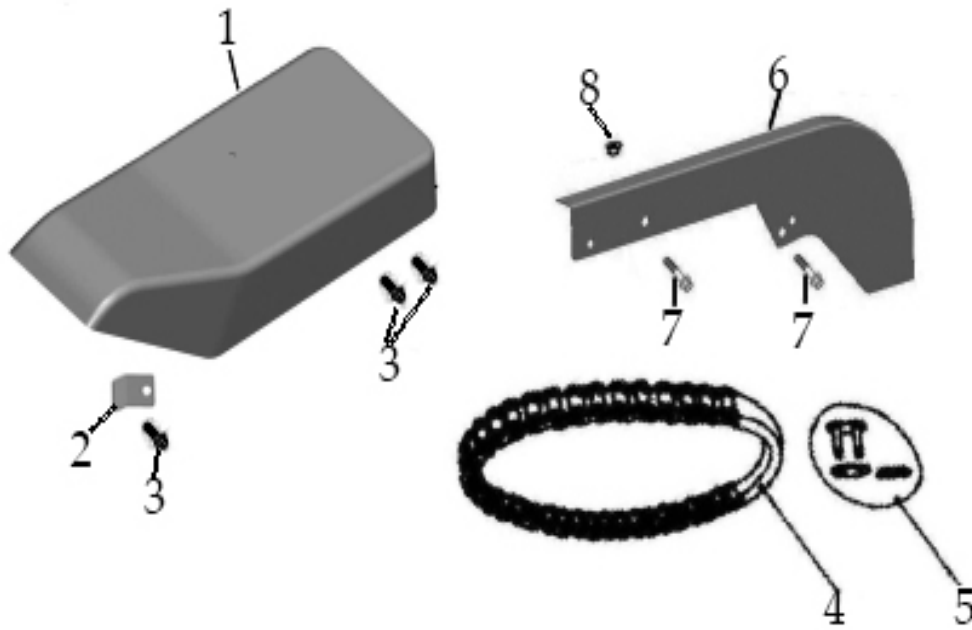
NO.	CODE	DESCRIPTION	QTY.
1	80025-XL	electrical wiring	1
2	58510-L	PEDAL COMP	2
3	57100-XL-01	FRAME COMP	1
4	6000-2RS	BEARING 6000-2RS	2
5	60001-XL	BUSH 10*17-109	1
7	58001-XL	FENDER	1
8	57890601610005	GB5789 BOLT M6*16	4
9	61770600010005	GB6177 NUT M6	4
10	58001-XL-01	DUMMY PLATE.L	1
11	57890601210005	GB5789 BOLT M6*12	2
12	58410--PL	SIDE STAND	1
13	58402-L	SIDE STAND BOLT	1
14	58401-L	SIDE STAND SPRING	1
15	M6-round-reflector-r	M6-round-reflector red	2
16	M5-rec-reflector-r	M5-rec-reflector red	1
	61700500008005	GB6170 NUT M6	1
	96000500000005	Washer $\phi$ 5	1

**FIG.3 FRONT FORK ASSY**



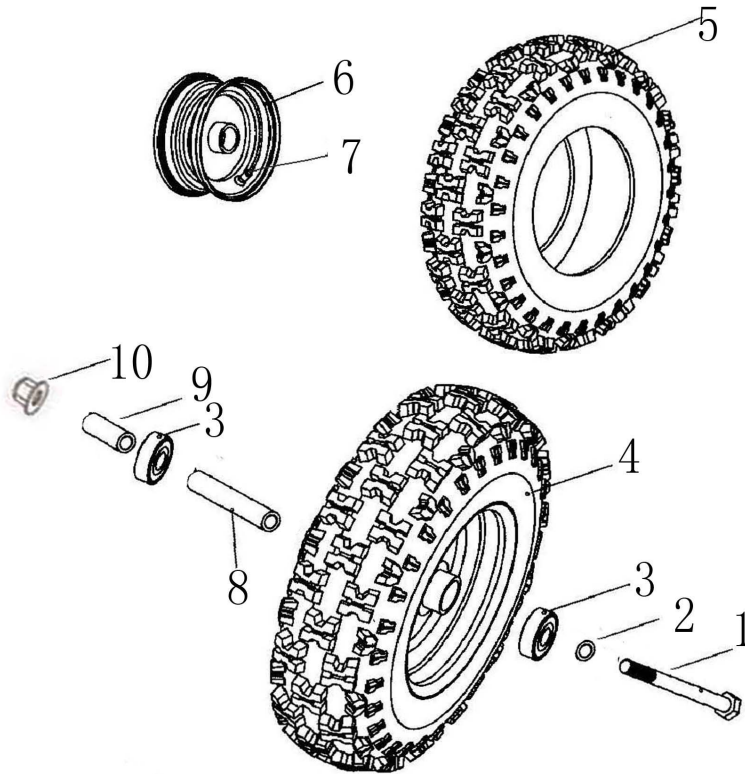
NO.	CODE	DESCRIPTION	QTY.
1	97001000000005	WASHER 10*1, GB97	1
2	57871016012505	GB5787 BOLT M10*1.25*160	1
3	61871000012505	GB6187 NUT M10*1.25	1
4	60100-XL-01	FRONT FORK WELDING COMP.	1
5	58001-XL	FENDER	1
6	57890601610005	GB5789 BOLT M6*16	4
7	61770600010005	GB6177 NUT M6	4
8	M6-round-reflector-y	M6-round-reflector yellow	2

**FIG.4 COVER, SEAT, CHAIN**



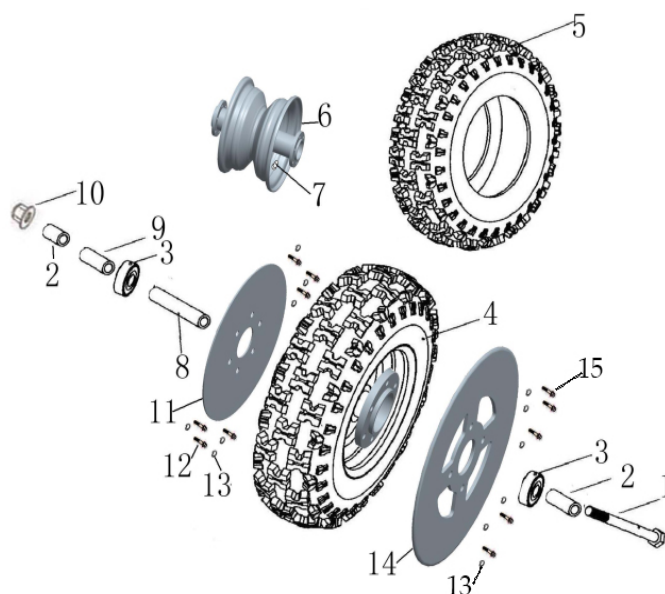
NO.	CODE	DESCRIPTION	QTY.
1	51020-XL	SEAT COMP	1
2	57870804512505	GB5787 BOLT M8*45	1
3	57870801612505	GB5787 BOLT M8*16	2
4	420-114	DRIVE CHAIN (420-114)	1
5	420-10	420 CHAIN MASTER LINK	1
6	58003-XL	CHAIN COVER	1
7	57890601210005	GB5789 BOLT M6*12	1
	57890600810005	GB5789 BOLT M6*8	1
8	61770600010005	GB6177 NUT M6	1

**FIG.5 FRONT WHEEL**



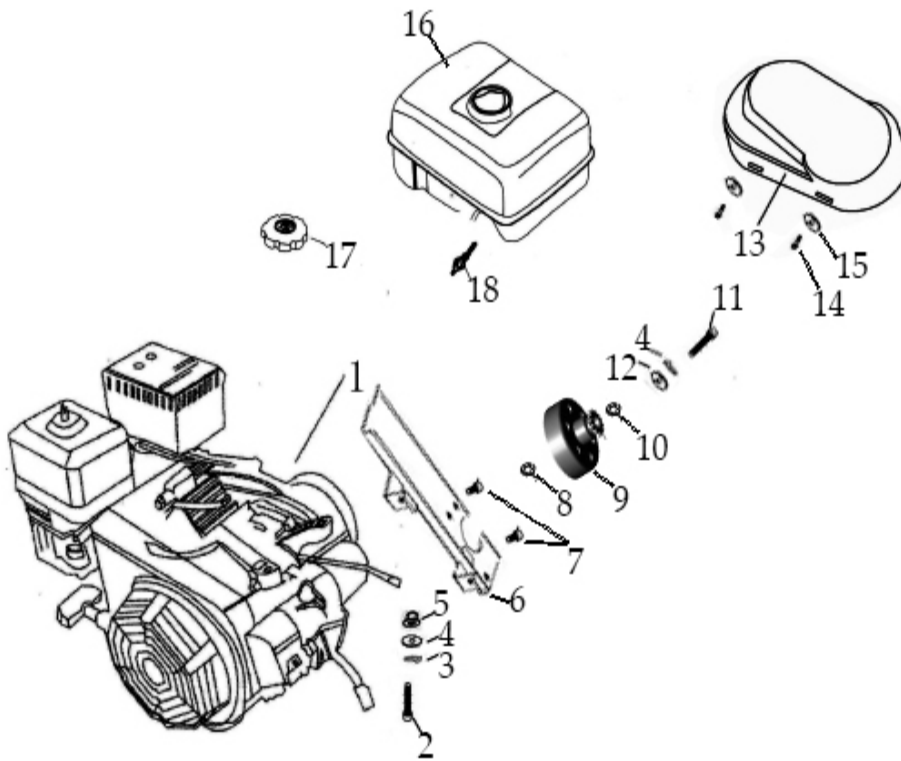
NO.	CODE	DESCRIPTION	QTY.
1	44001-XL	FRONT AXLE M12x1.25x230	1
2	97001200000005	WASHER $\phi$ 12, GB97	1
3	6201-2RS	BEARING 6201-2RS	2
4	44100-XL	FRONT WHEEL ASSY	1
5	44003-XL	TIRE 145/70-6	1
6	44110-XL	RIM, FRONT WHEEL	1
7	7190018250G000	TIRE NIPPLE	1
8	44002-XL	FRONT SPACER BUSHING $\phi$ 13* $\phi$ 18*162.5	1
9	54004-XL	BUSHING $\phi$ 13* $\phi$ 18*13	1
10	61871200012505	GB6187 NUT M12*1.25	1

**FIG.6 REAR WHEEL**



NO.	CODE	DESCRIPTION	QTY.
1	54001-XL	REAR AXLE M12x1.25x230	1
2	54004-XL	BUSHING $\phi$ 13* $\phi$ 18*13	2
3	6201-2RS	BEARING 6201-2RS	2
4	54100-XL	REAR WHEEL ASSY	1
5	44003-XL	TIRE 145/70-6	1
6	44010-L	TIRE NIPPLE (90°)	1
7	54110-XL	RIM, REAR WHEEL	1
8	44002-XL	FRONT SPACER BUSHING $\phi$ 13* $\phi$ 18*162.5	1
9	54005-XL	BUSHING $\phi$ 13* $\phi$ 18*18	1
10	61871200012505	GB6187 NUT M12*1.25	1
11	54006-XL	BRAKE DISC	1
12	57890601610005	GB5789 BOLT M6*16	6
13	93000600000005	LOCKING WASHER $\phi$ 6, GB93	12
14	8.010.200-80-50XL	REAR SPROCKET (60T-420)	1
15	57890602010005	GB5789 BOLT M6*20	6

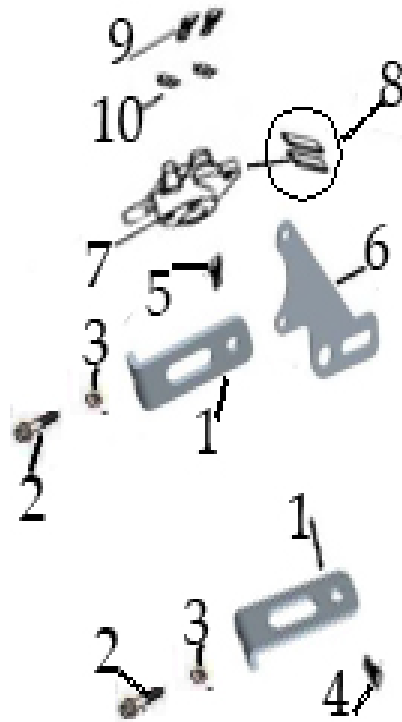
**FIG.7 ENGINE, CLTUCH COMP**



NO.	CODE	DESCRIPTION	QTY.
1	10000-XL	ENGINE COMP. MX196-2	1
2	57870804012505	GB5787 BOLT M8*40	4
3	97000800000005	WASHER $\phi$ 8, GB97	4
4	93000800000005	LOCK WASHER $\phi$ 8 ,GB93	5
5	61870800012505	GB6187 NUT M8	4
6	58200-XL	CLUTCH COVER MOUNTING PLATE	1
7	57870801212505	GB5787 BOLT M8*12	2
8	10011-XL-01	CLUTCH BUSH 20*30-10	1
9	1411020050G000	CLUTCH (10Z)	1
10	10012-XL-01	CLUTCH BUSH 20*30-6	1
11	57870804012505	GB5787 BOLT M8*25	1
12	96000800000005	WASHER $\phi$ 8, GB96	1
13	65008-L	CLUTCH COVER	1
14	57890601610005	GB5789 BOLT M6*16	2
15	96000600000005	WASHER $\phi$ 6, GB96	2
16	50100-LA	FUEL TANK COMP(JD)	1
17	6000145080G001	FUEL FILLER CAP COMP(JD)	1
18	JF168-N-08	FUEL TANK SWITCH	1



**FIG.8 BRAKE, CHAIN TENSIONING PLATE**



NO.	CODE	DESCRIPTION	QTY.
1	58012-XL-01	CHAIN TENSIONING PLATE	2
2	57850605010005	GB5785 BOLT M6*50	2
3	61770600010005	GB6177 NUT M6	2
4	57870801212505	GB5787 BOLT M8*12	1
5	57870801612505	GB5787 BOLT M8*16	1
6	57103-XL-01	BRAKE MOUNTING PLATE	1
7	45000-50XL	BRAKE ASSY	1
8	7120060050G000	BRAKE CALIPER ASSY	
9	70000602010002	GB70 BOLT M6*20	2
10	930006000000005	LOCKING WASHER $\phi$ 6, GB93	2
	970006000000005	WASHER $\phi$ 6, GB97	2
11	57890601210005	GB5789 BOLT M6*12	1

FIG.9 WARNING STICKERS



NO.	CODE	DESCRIPTION	QTY.
1	90002-50L	LABEL.WARNING 1	1
2	90007-50L	LABEL.WARNING 2	1
3	90001-50L	LABEL.WARNING 3	1
4	90006-50L	LABEL.WARNING 4	1
5	90004-50L	LABEL.WARNING 5	1
6	90003-50L	LABEL.WARNING 6	1
7	90901-50XL	EPA Hang tag	1
8	90902-50L	EPA anti-counterfeiting labeling	1
9	90771-50L	Owner's Manual	1
10	7110003-50L	SPARK PLUG SOCKET	1
11	STORM 200 STICKER	STORM 200 STICKER	2