

SORRENTO 50/150

PARTS

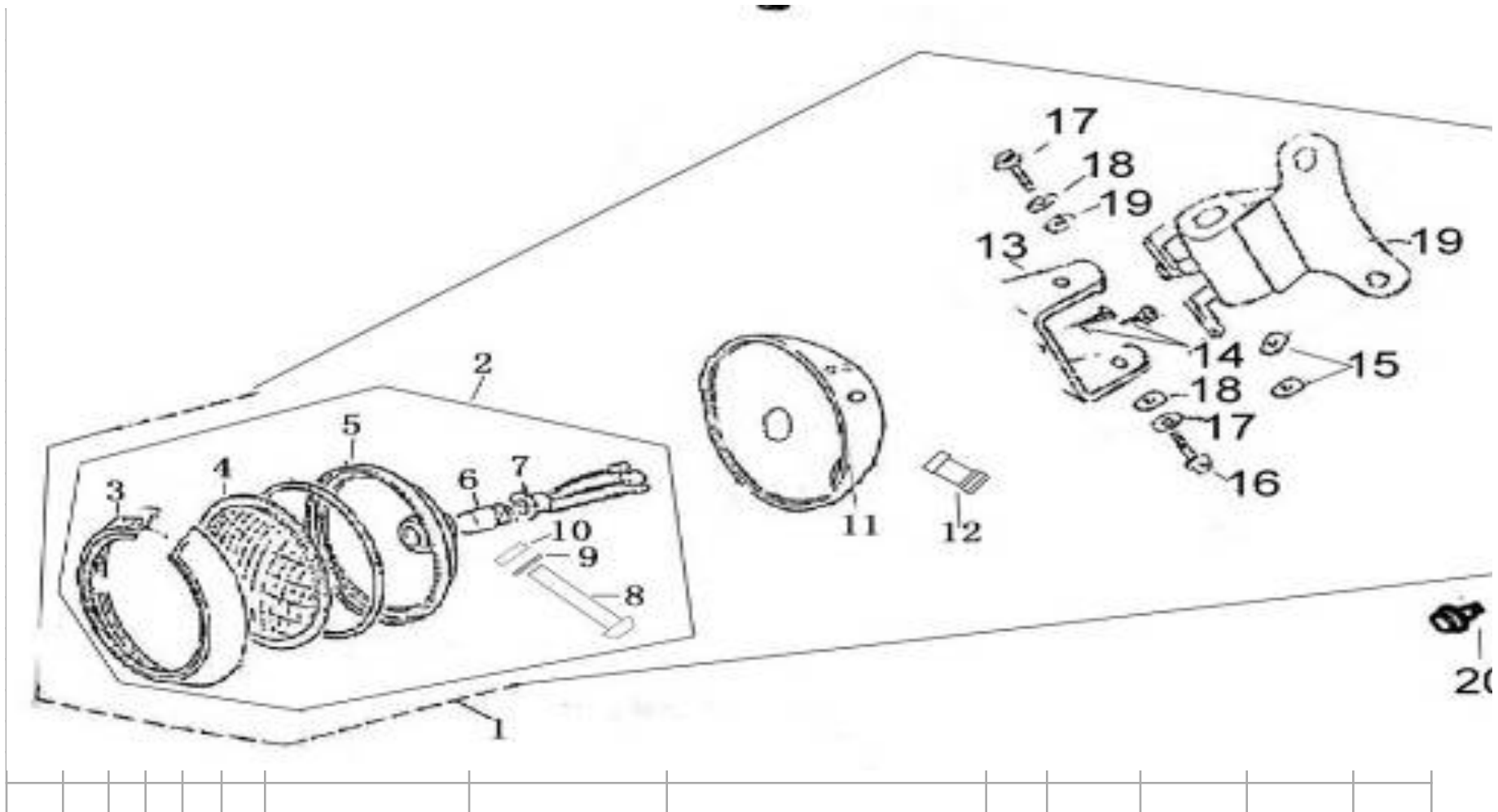



ZN150T-H(PK150T-BEETLE)零部件图册 F01

页码	区分					部品编号	部品名称(英)	部品名称(中)	数量	版次	仓库号	设变记事	设变日期
	主	附	细	细	细								
F01	1					33100-DGW-9000	LIGHT ASSY HE	前灯组	1		B		

F01		2			33129-DGW-9000	HEAD LIGHT	前灯	1		B		
F01			3		33108-DGW-9000	LIGHT FRAME	灯框	1		B		
F01			4		33102-DGW-9000	SHELL HEAD LI	前灯壳	1		B		
F01			5		33101-DGW-9000	REFLECTOR HE	前灯反射碗	1		B		
F01			6		34901-F8-9000	BULB HEAD LIC	前灯泡	1		B		
F01			7		33130-DGW-9000	SOCKET COMP	插座总承	1		B		
F01			8		93201-03040-09	S C R E W	前灯框锁付螺丝	1		B		
F01			9		95801-03000-09	WASHER 3mm	前灯框锁付垫片	2		B		
F01			10		95001-03000	NUT HEX 3mm	前灯框锁付螺帽	1		B		
F01		11			33103-DGW-9000	BASE HEAD LIC	前灯座	1		B		
F01		12			3 3 1 0 9 -	RUBBER BUSH	橡胶塞	1		B		
F01		13			51602-DGW-9000	CONNECTER HE	灯座联板	1		B		
F01		14			92101-06016-09	BOLT FLANGE 6*	大灯固定螺丝 (不锈钢)	2		B		
F01		15			95801-06000-09	SPG WANSHER 6M	弹簧垫圈 (不锈钢)	2		B		
F01		16			92201-08016-09	BOLT HEX8*16	支架固定螺丝 (不锈钢)	2		B		
F01		17			95801-08000-09	WASHER	平面垫片 (不锈钢)	2		B		
F01		18			95901-08000-09	WASHER SPG	弹簧垫圈 (不锈钢)	2		B		
F01		19			61311-DGW-9000	HEADLIGHT STAY	大灯安装支架连接板	1		B		
F01	20				92101-06016-03	BOLT FLANGE 6*	大灯固定螺丝(军绿)	2		H		

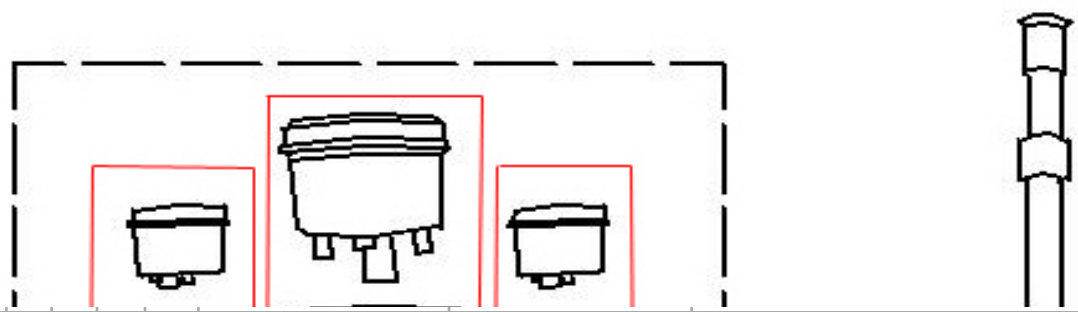

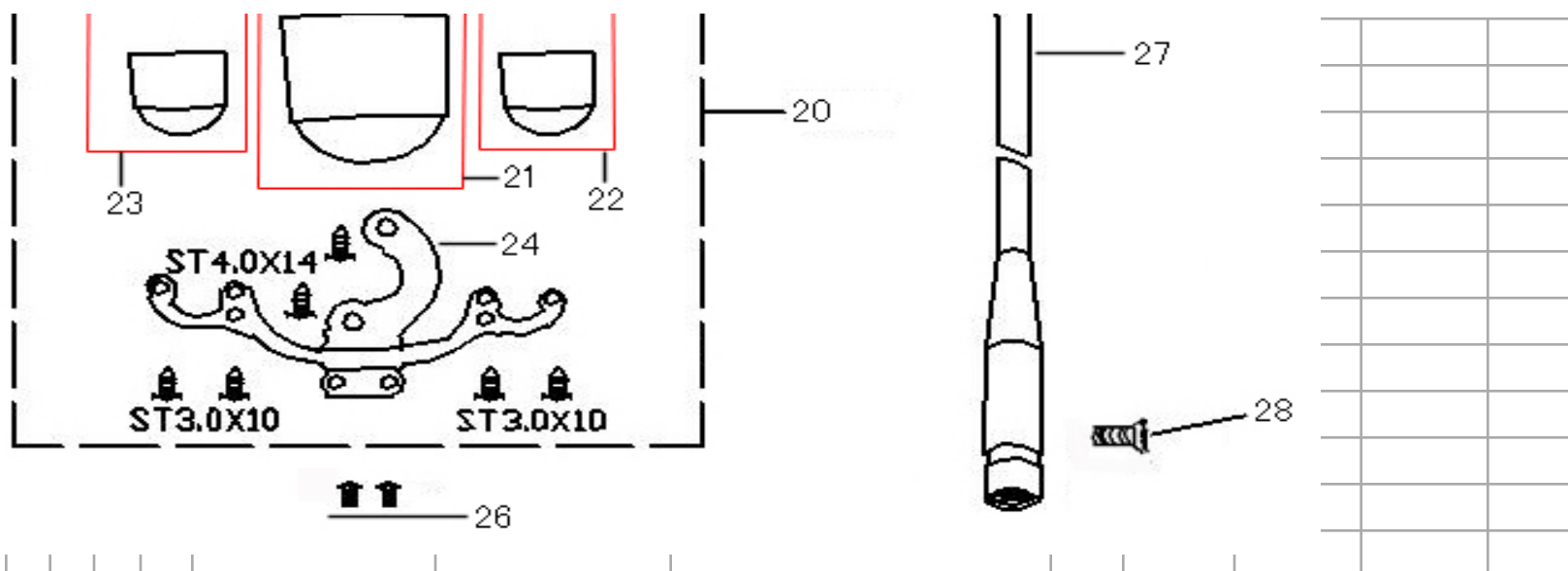

ZN150T-H(PK150T-BEETLE) 零部件图册

F02

页码	区分					部品编号	部品名称(英)	部品名称(中)	数量	版次	仓库号	设变记事	设变日期
	主	附	细	细	细								
F02	20					37200-DGW-E000	SPEED METER A	仪表组	1		B		
F02		21				37201-DGW-E000	SPEED METER	速度表	1		B		
F02		22				37202-DGW-9000	OIL DIGIT METE	燃油表	1		B		
F02		23				37203-DGW-9000	TURNING INST	转向指示表	1		B		
F02		24				61312-DGW-9000	SPEEDOMETER	仪表支架	1		B		
F02		~				34908-DGW-9000	BULB WEDGE B	远灯、方向灯指示灯	3		B		
F02		~				34909-DGW-9000	BULB WEDGE B	仪表夜灯灯泡	3		B		
F02	26					93201-05012-03	SCREW PAN 5*1	仪表固定螺丝(军绿)	2		H		
F02	27					44830-DGW-9000	CABLE COMP S	里程表软轴	1		B		

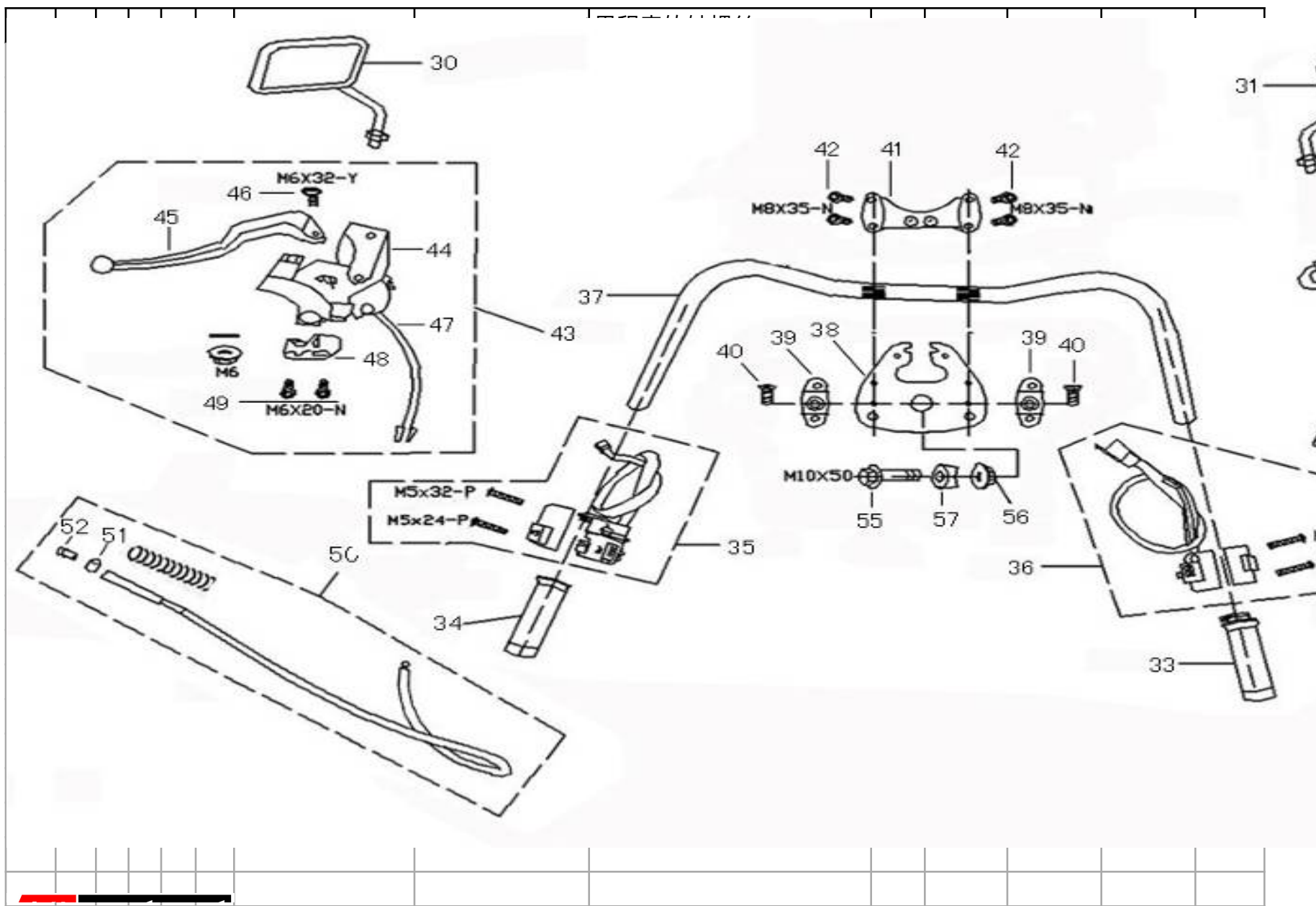

ZN150T-H(PK150T-BEETLE) 零部件图册 F03

页码	区分					部品编号	部品名称(英)	部品名称(中)	数量	版次	仓库号	设变记事	设变日期
	主	附	细	细	细								
F03	30					88120-DGW-E000	MIRROR ASSY L	左后视镜	1		C	2	
F03	31					88110-DGW-E000	MIRROR ASSY R	右后视镜	1		C	2	
F03	32					17910-DGW-9000	CABLE COMP T	油门拉线	1		B		
F03	33					53140-DGW-9000	GRIP COMP THR	加油手把套	1		B		
F03	34					53166-DGW-9000	GRIP L HANDLE	左手把套	1		B		
F03	35					3520A-DGW-A000	SW ASSY LH HN	左开关组	1		B		
F03	36					3515A-DGW-A000	SW ASSY RH HN	右开关组	1		B		
F03	37					53100-DGW3-900	HANDLE COMP	转向手把	1		M		
F03	38					53230-DGW-9000	BRIDGE FORK T	上联板	1		M		
F03	39					53131-DGW-9000	HOLDER HANDI	手把下固定座	2		F		
F03	40					92501-08016-03	BOLT SPECIAL 8	下固定座螺丝	2		H		
F03	41					53132-DGW-9000	HOLDER HANDI	手把上固定座	1		F		
F03	42					92501-08035-09	BOLT SPECIAL 8	上固定座螺丝 (不锈钢)	4		K		
F03	43					5317B-DGW-9000	BRKT ASSY HA	左刹把组件	1		B		
F03		44				53172-DGW-9000	BRKT HANDLE	手柄左托架	1		B		
F03		45				53178-DGW-9000	LEVER L STRG I	左刹把	1		B		
F03		46				90115-DGW-9000	BOLT HNDL LEV	拉杆螺丝	1		B		
F03		47				35340-DGW-9000	SW ASSY FR STC	后刹车开关	1		B		
F03		48				45517-DGW-9000	HOLDER HNDL	手柄固定座夹板	1		B		
F03		49				92501-06020-09	BOLT SPECIAL 6	左刹把组固定螺丝 (不锈钢)	2		B		
F03	50					43450-DGW-9000	CABLE COMP R	后刹车导线	1		B		
F03		51				95015-32001	JOINT B BRAKE	刹车臂连接器	1		B		

ZN150T-H(PK150T-BEETLE) 零部件图册 F04

页码	区分				部品编号	部品名称(英)	部品名称(中)	数量	版次	仓库号	设变记事	设变日期
	主	附	细	细								
F04	60				4550A-DGW-E000	SUB HARNESS S	前碟刹总成	1		G		
F04		61			45500-DGW-9000	SUB HARNESS S	碟刹上泵	1		G		
F04			62		53175-DGW-9000	HANDLE	手柄	1		G		
F04			63		45501-DGW-9000	CYLINDER BOD	缸体	1		G		
F04			65		10099-F8-9000	SHUT-OFF BLOC	前刹车开关	1		G		
F04			66		92501-06020-09	BOLT SPECIAL 6	碟刹上泵固定螺丝(不锈钢)	2		G		
F04		67			45126-DGW-9000	HOSE ASSY FR F	前刹车油管	1		G		
F04		68			90045-F8-9000	OIL BOLT 10*22	油道螺丝10*22	2		G		
F04		69			90046-F8-9000	WASHER OIL BC	垫圈	4		G		
F04		70			45200-DGW-E000	CALIPER ASSY I	碟刹下泵	1		G		
F04			71		45105-DGW-E000	PAD COMP A	刹车摩擦板A	1		G		
F04			72		45106-DGW-E000	PAD COMP B	刹车摩擦板B	1		G		

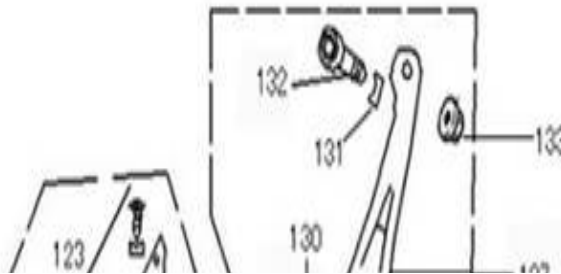

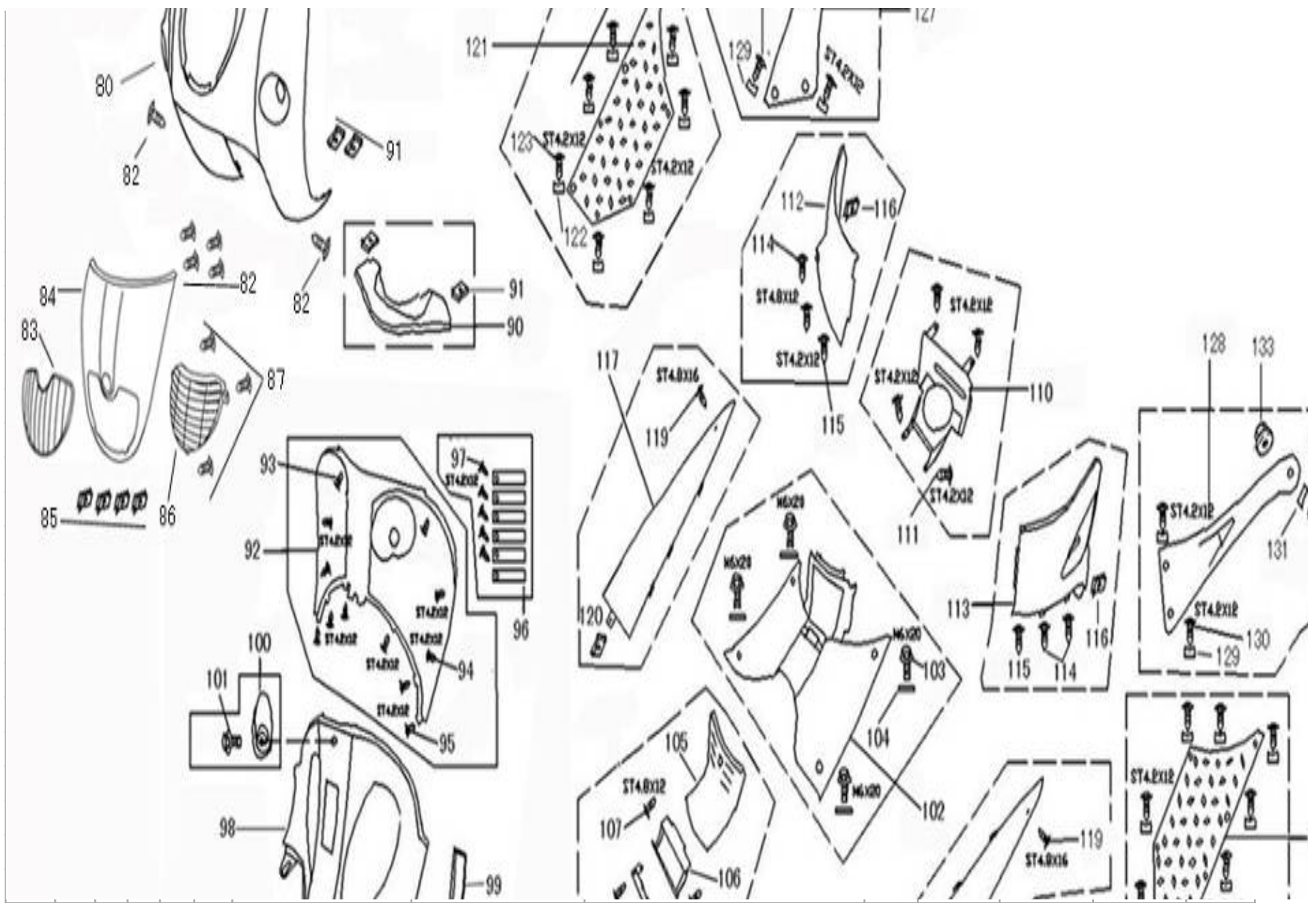

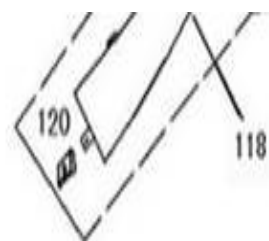
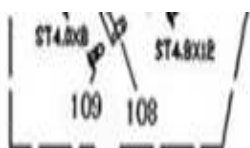

ZN150T-H(PK150T-BEETLE) 零部件图册 F05

页码	区分					部品编号	部品名称(英)	部品名称(中)	数量	版次	仓库号	设变记事	设变日期
	主	附	细	细	细								
F05	80					64301-DGW3-900	COVER FR	前面板	1		D	15	
F05	81					90701-DGW-9000	NUT SPRING 6M	6MM卡片	2		H		
F05	82					93401-48016-03	SCREW TAPPING	前面板螺丝 (G)	6		H		
F05	83					64311-DGW3-900	VENTILATION C	前面板通风隔	1		A		
F05	84					64303-DGW3-900	LID, FR. COVER	前面板装饰件	1		A		
F05	85					90601-F8-9000	NUT SPRING 4M	4MM卡片	4		H		
F05	86					64312-DGW3-900	WITHIN VENTIL	通风口内隔板	1		A		
F05	87					93401-42012-03	SCREW TAPPING	内隔板螺丝	3		H		
F05	88					64329-DGW2-900	UPPER, FRONT C	前面板上压板上部	1		A		
F05	89					93001-06017-03	SCREW SPECIAL	前面板上压板上部螺丝	2		H		
F05	90					64328-DGW2-900	LOWER, FRONT	前面板上压板下部	1		A		
F05	91					90601-F8-9000	NUT SPRING 4M	4MM卡片	2		H		
F05	92					81131-DGW2-900	LEG SHIELD LO	工具箱上部	1		D	10	
F05	93					93401-42016-03	SCREW TAPPING	工具箱上部结合上压板螺丝	2		H		
F05	94					93401-42012-03	SCREW TAPPING	工具箱上部结合前面板螺丝	4		H		
F05	95					93401-42012-03	SCREW TAPPING	上下工具箱结合螺丝	6		H		

F05	96			94591-17500	CLIP 1*75	线夹1*75	7		F		
F05	97			93401-42010-03	SCREW TAPPING	线夹固定螺丝	5		H		
F05	98			81141-DGW2-900	LEG SHIELD LO	工具箱下部	1		A		
F05	99			81142-DGW2-900	LID LEG SHIELD	车架号码盖	1		A		
F05	100			83760-DGW2-900	CLIP ASSY CENT	安全帽挂钩	1		A		
F05	101			92101-06030-03	BOLT FLANGE 6	安全帽挂钩螺丝	1		H		
F05	102			64310-DGW2-900	FLOOR PANEL	脚踏底板	1		A		
F05	103			92101-06020-03	BOLT FLANGE 6	脚踏底板螺丝	4		H		
F05	104			95801-06000-03	WASHER Φ6	垫片Φ6	4		H		
F05	105			17601-DGW2-900	FUEL FLAP	加油口盖	1		A		
F05	106			19009-DGW2-900	ROCKER,FUEL F	加油口盖摇臂	1		A		
F05	107			93401-42012-03	SCREW TAPPING	加油口盖摇臂螺丝	2		H		
F05	108			19010-DGW2-900	BRACKET,ROCK	加油口盖摇臂压片	1		F		
F05	109			93502-04008-03	SCREW TAPPING	加油口盖摇臂压片断头螺丝	2		K		
F05	110			17600-DGW2-900	PLATE TANK OP	油箱口压板	1		A		
F05	111			93401-42012-03	SCREW TAPPING	油箱口压板螺丝	4		H		
F05	112			83761-DGW2-900	R CONNECTING	右连接板	1		A		
F05	113			83762-DGW2-900	L CONNECTING	左连接板	1		A		
F05	114			93401-48012-03	SCREW TAPPING	连接板螺丝 (军绿色)	4		H		
F05	115			93401-42012-03	SCREW TAPPING	连接板螺丝 (军绿色)	2		H		
F05	116			90601-F8-9000	NUT SPRING 4M	4MM卡片	2		H		
F05	117			64305-DGW2-900	SKIRT R SIDE	右护条	1		D	6	
F05	118			64306-DGW2-900	SKIRT L SIDE	左护条	1		D	6	
F05	119			93401-48016-03	SCREW TAPPING	护条螺丝 (G)	2		H		
F05	120			90601-F8-9000	NUT SPRING 4M	4MM卡片	2		H		
F05	121			64311-DGW-9000	MAT FLOOR R	右脚踏皮 (铝)	1		C		
F05	122			90121-DGW-9000	COLLAR	脚踏皮衬套	8		C		
F05	123			93401-42012-09	SCREW TAPPING	脚踏皮螺丝 (不锈钢)	8		C		
F05	124			64312-DGW-9000	MAT FLOOR L	左脚踏皮 (铝)	1		C		

F05	125			90121-DGW-9000	COLLAR	脚踏皮衬套	8		C		
F05	126			93401-42012-09	SCREW TAPPING	脚踏皮螺丝 (不锈钢)	8		C		
F05	127			64313-DGW-9000	COVER R CONN	右连接板装饰板	1		C		
F05	128			64314-DGW-9000	COVER L CONN	左连接板装饰板	1		C		
F05	129			90121-DGW-9000	COLLAR	装饰板衬套	4		C		
F05	130			93401-42012-09	SCREW TAPPING	装饰板螺丝 (不锈钢)	4		C		

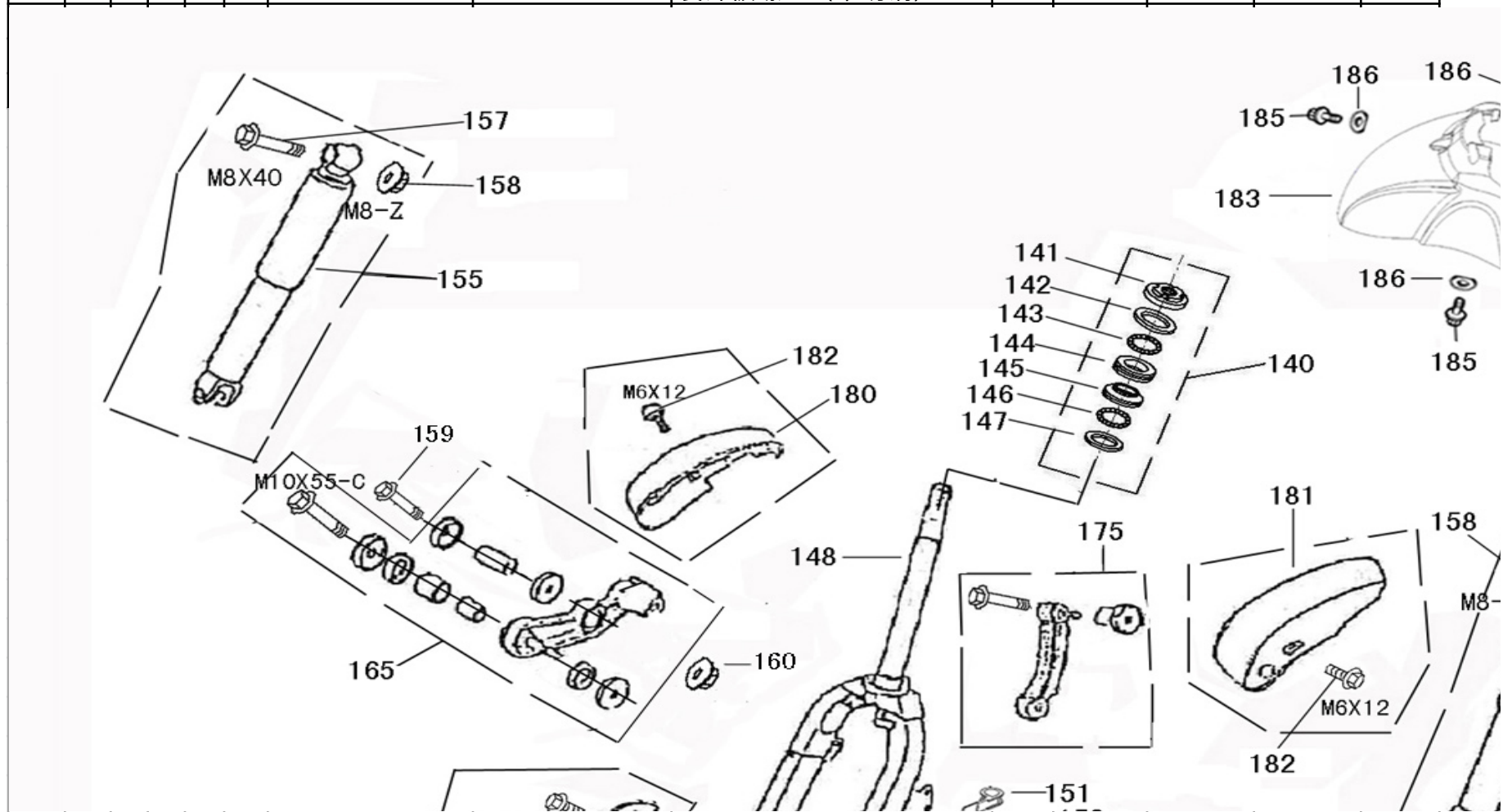

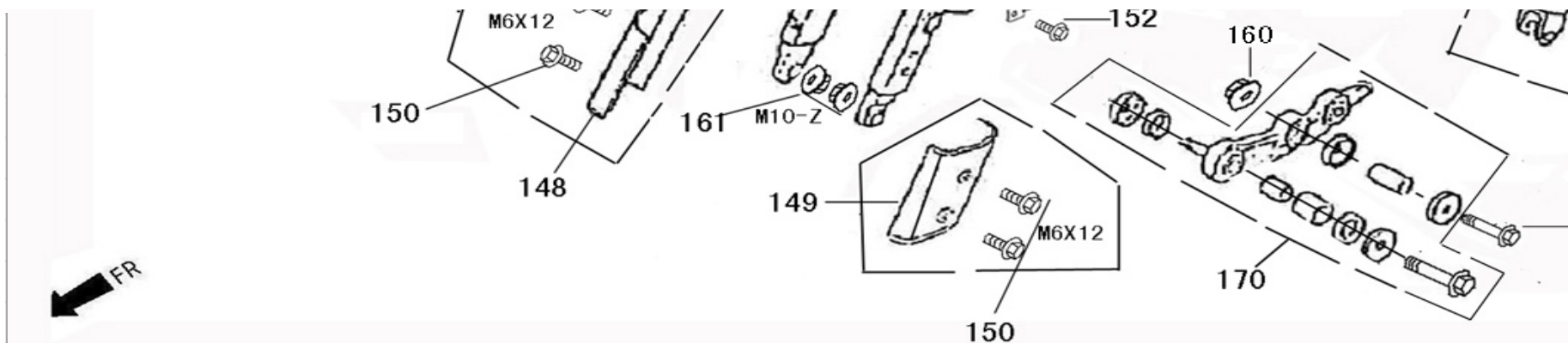

动感中能 感动世界

ZN150T-H(PK150T-BEETLE) 零部件图册 F06

页码	区分					部品编号	部品名称(英)	部品名称(中)	数量	版次	仓库号	设变记事	设变日期
	主	附	细	细	细								
F06	140					50300-F8-9000		全套钢碗	1		G		
F06		141				50306-F8-9000	NUT STRG STEM	主杆锁紧螺帽	1		G		
F06		142				53211-F8-9000	RACE STRG TOP	上锥体座圈	1		G		
F06		143				53213-F8-9000	BALL STEEL	保持架钢珠	1		G		
F06		144				50301-F8-9000	RACE UP STRG	上珠碗	1		G		
F06		145				50302-F8-9000	RACE (STRG BO	下珠碗	1		G		
F06		146				53214-F8-9000	BALL STEEL	保持架钢珠	1		G		
F06		147				53212-F8-9000	RACE (STRG BO	下锥体座圈	1		G		
F06	148					53200-DGW-9000	FORK COMP FR	前叉	1		G		

F06	149			51101-DGW2-900	COVER R FR FO	右前叉护盖	1		A		
F06	150			51102-DGW2-900	COVER L FR FO	左前叉护盖	1		A		
F06	150			92101-06012-03	BOLT FLANGE 6	前叉护盖螺丝 (军绿)	4		H		
F06	151			43128-F8-9000	STAY HOSE	前碟刹管线夹	1		G		
F06	152			92101-06012-03	BOLT FLANGE 6	BF6*12 (军绿)	1		H		
F06	155			51400-DGW-9000	CUSHION ASSY	右前减震器	1		G		
F06	156			51500-DGW-9000	CUSHION ASSY	左前减震器	1		G		
F06	157			92201-08038-03	BOLT FLANGE 8	减震器上螺丝	2		H		
F06	158			95401-08000-03	NUT U FLANGE	减震器上安全螺帽	2		H		
F06	159			94501-08035-03	BOLT 8*35	减震器下螺丝(十字平头台阶)	2		H		
F06	160			95401-08000-03	NUT U FLANGE	减震器下安全螺帽	2		H		
F06	161			95401-10000-03	NUT U FLANGE	摇臂与前叉结合螺帽	2		H		
F06	165			4541A-DGW-9000	R ROCKER ASSY	右摇臂组件	1		G		
F06		~		45410-DGW-9000	R ROCKER	右摇臂	1		G		
F06		~		91202-DGW-9000	OIL SEAL	油封	2		G		
F06		~		45411-DGW-9000	COLLER	前减震器轴衬	1		G		
F06		~		45412-DGW-9000	COLLER	前减震器轴环	1		G		
F06		~		45413-DGW-9000	COLLER	摇臂轴环	1		G		
F06		~		45414-DGW-9000	DUST SEAL	前减震器底座防尘封	2		G		
F06		~		45415-DGW-9000	COVER DUST SI	前减震器底座防尘封盖	2		G		
F06	170			4542A-DGW-9000	L ROCKER ASSY	左摇臂组件	1		G		
F06		~		45420-DGW-9000	L ROCKER	左摇臂	1		G		
F06		~		91202-DGW-9000	OIL SEAL	油封	2		G		
F06		~		45411-DGW-9000	COLLER	前减震器轴衬	1		G		
F06		~		45412-DGW-9000	COLLER	前减震器轴环	1		G		
F06		~		45413-DGW-9000	COLLER	摇臂轴环	1		G		
F06		~		45414-DGW-9000	DUST SEAL	前减震器底座防尘封	2		G		

F06		~		45415-DGW-9000	COVER DUST SH	前减震器底座防尘封盖	2		G		
F06	175			45430-DGW-9000	DISK BRAKE RC	前碟刹摇臂	1		G		
F06		~		45438-DGW-9000	BOLT FLANGE 1	碟刹摇臂锁付螺丝(十字平头)	1		G		
F06		~		45439-DGW-9000	BUT DISC BRAK	碟刹摇臂锁付螺帽	1		G		
F06	180			51103-DGW2-900	COVER R PIVOT	摇臂右护盖	1		A		
F06	181			51104-DGW2-900	COVER L PIVOT	摇臂左护盖	1		A		
F06	182			92101-06012-03	BOLT FLANGE 6	摇臂护盖螺丝 (军绿)	2		H		
F06	183			61100-DGW2-900	FR INNER FEND	前轮挡泥板前部	1		D	10	
F06	184			61103-DGW-9000	DECORATION A	前轮挡泥板银条(选配)	1		B		
F06	185			92702-06016-03	SCREW SPECIAL	前轮挡泥板螺丝	3		H		
F06	186										
F06	187										
F06	188										
F06	189										

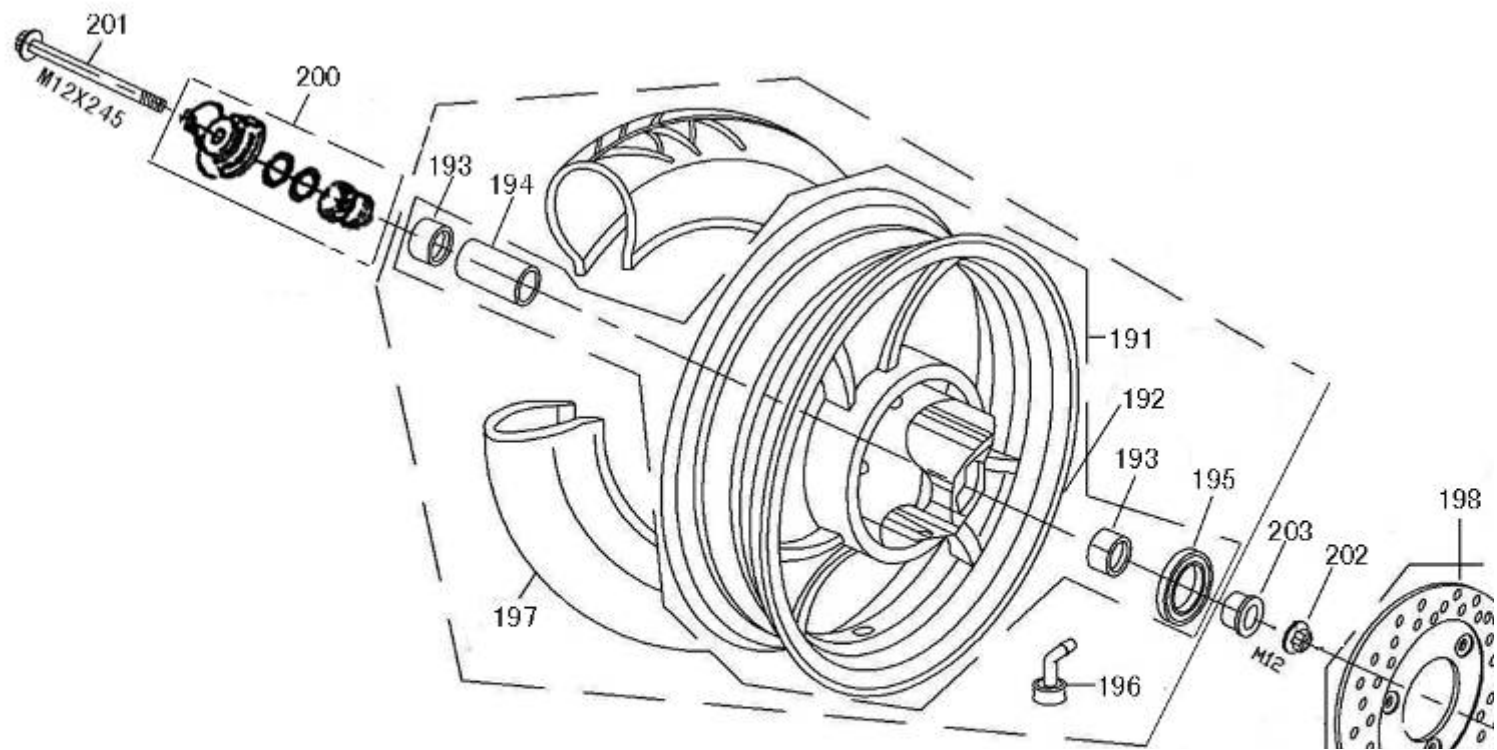



ZN150T-H(PK150T-BEETLE) 零部件图册 F07

页码	区 分				部品编号	部品名称(英)	部品名称(中)	数量	版次	仓库号	设变记 事	设变 日期
	主	附	细	细								
F07	191				44600-DGW-9000	WHEEL SET FR	前轮框组MT2.50X10	1		F		
F07		192			44601-DGW-9000	WHEEL FR CAS	前轮框	1		F		
F07		193			96002-62010	BEARING 6201 L	轴承 6201 LLU	2		F		
F07		194			44620-DGW-9000	COLLAR FR DIS	前轮轴内套筒	1		F		
F07		195			91001-F8-9000	DUST SEAL 20*3	油封 20*32*5	1		F		
F07	196				42753-DGW-9000	VALVE(PVR-70)	气门嘴	1		F		
F07	197				44710-DGW-9000	TIRE ASSY	轮胎3.50-10	1		F		
F07	198				45121-F8-E000	DISK FR BRAKE	前碟刹盘	1		G		
F07	199				45122-F8-E000	DISK FR BRAKE	前碟刹盘螺栓	1		G		
F07	200				45123-F8-E000	DISK FR BRAKE	前碟刹盘螺母	1		G		

F07	2
F07	2
F07	2

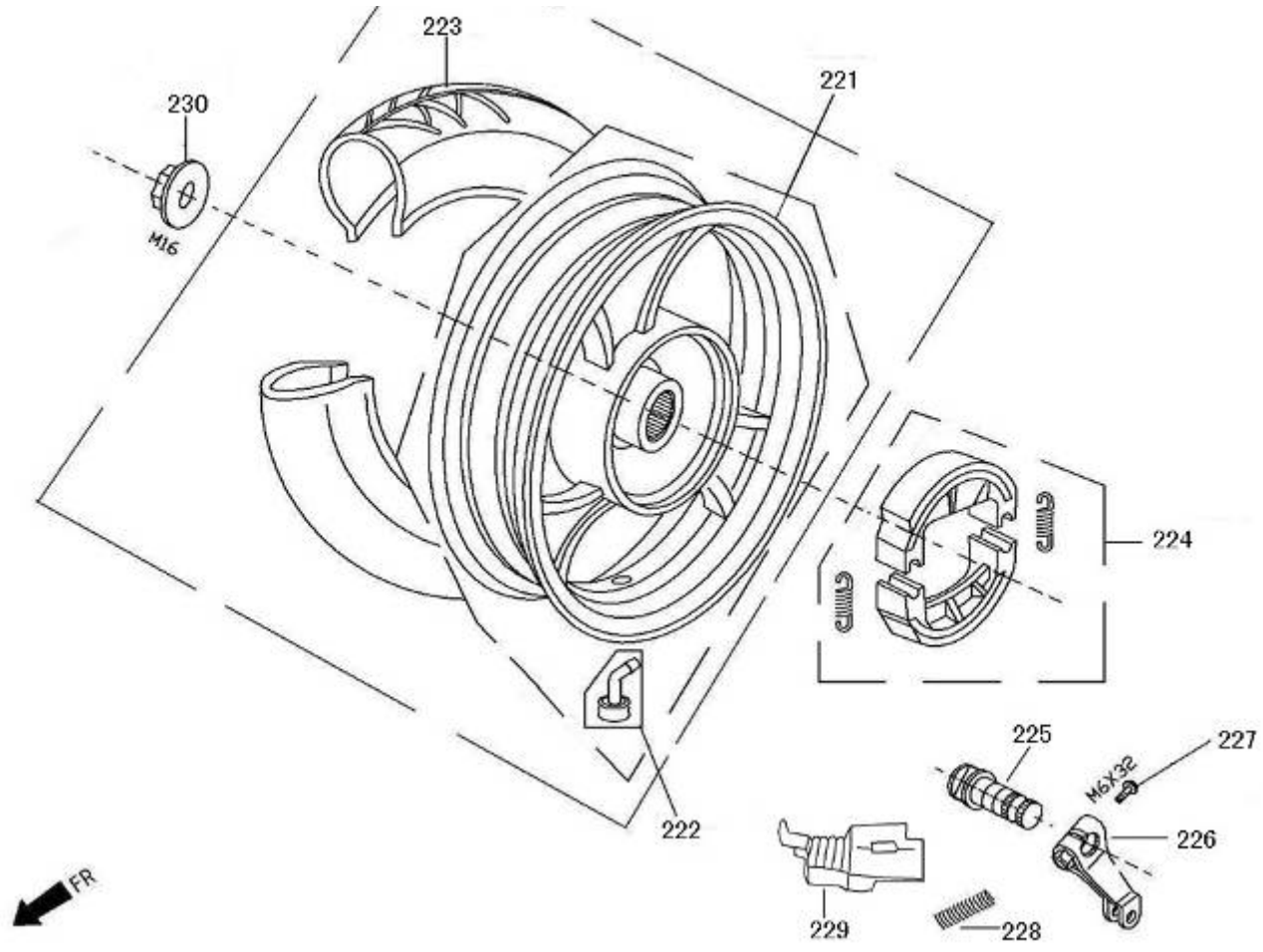

H		
H		
H		



ZN150T-H(PK150T-BEETLE) 零部件图册 F08

页码	区分					部品编号	部品名称(英)	部品名称(中)	数量	版次	仓库号	设变记事	设变日期
	主	附	细	细	细								
F08	221					42600-DGW-9000	WHEEL COMP R	后轮圈	1		F		
F08	222					42753-DGW-9000	VALVE(PVR-70)	气门嘴	1		F		
F08	223					44710-DGW-9000	TIRE ASSY	轮胎	1		F		
F08	224					4312A-DGW-E000	SHOE SET BRAK	后刹蹄块	1		G		
F08	225					43141-DGW-9000	CAM RR BRK	后刹车摇臂轴	1		G		
F08	226										G		
F08	227										H		
F08	228										G		
F08	229										B		
F08	230										H		

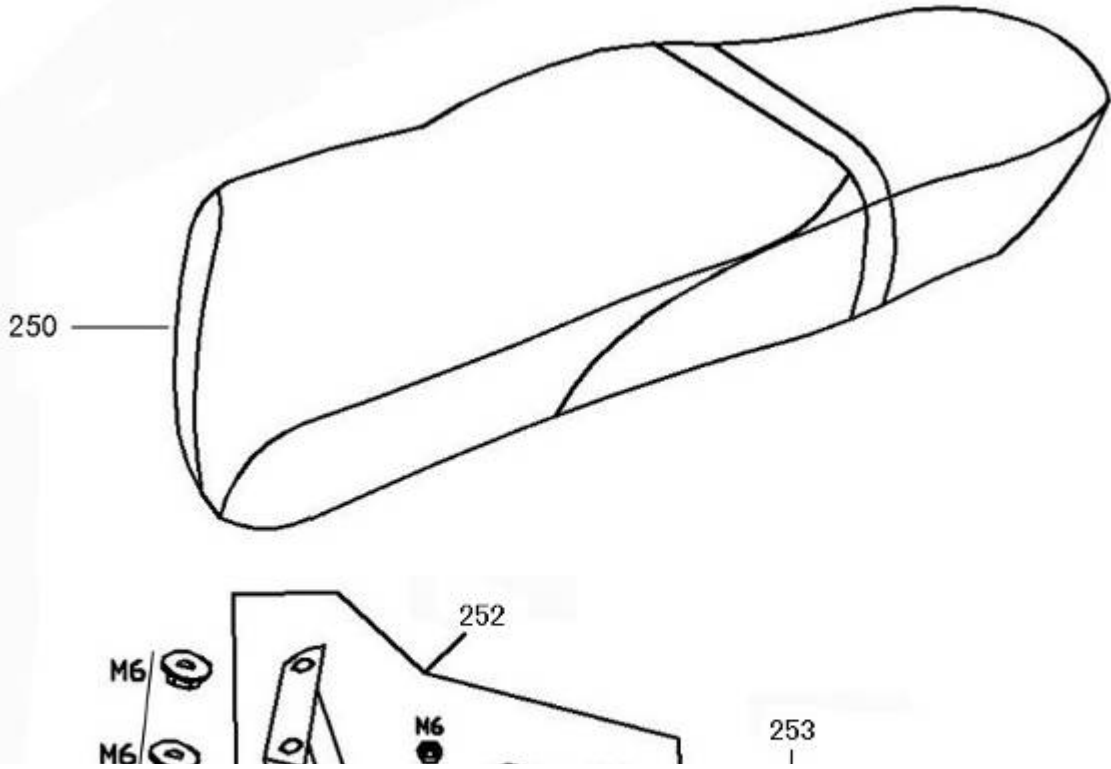

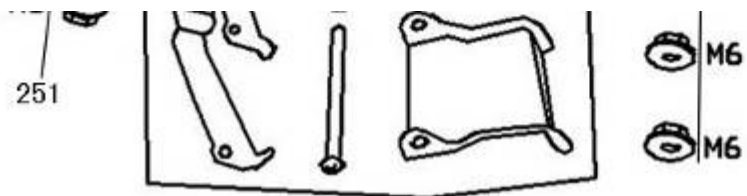

ZN150T-H(PK150T-BEETLE) 零部件图册 F09

页码	区分				部品编号	部品名称(英)	部品名称(中)	数量	版次	仓库号	设变记事	设变日期
	主	附	细	细								

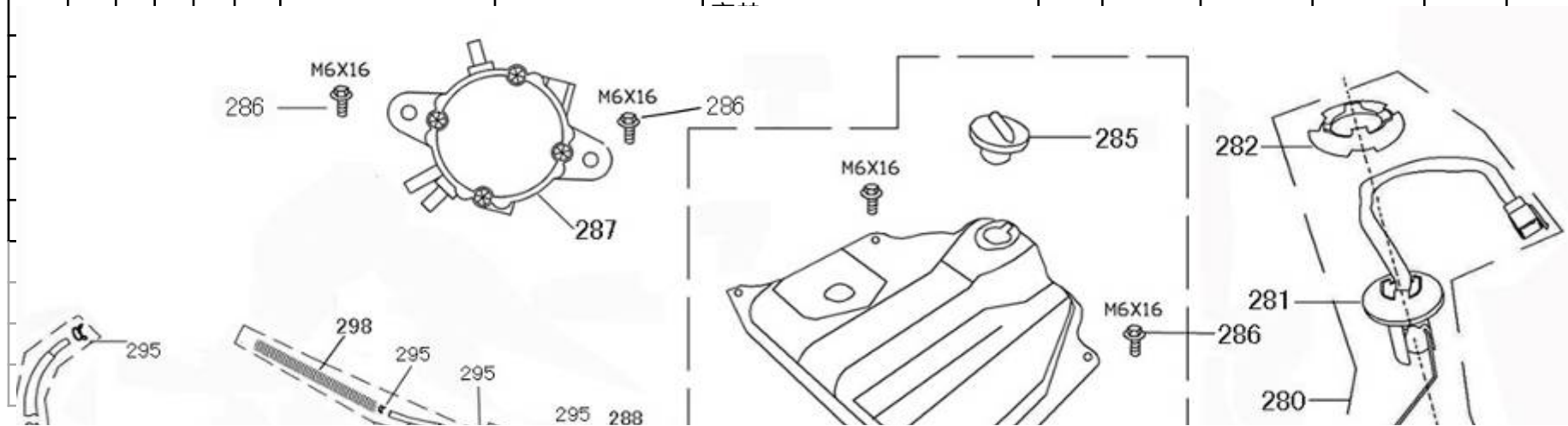

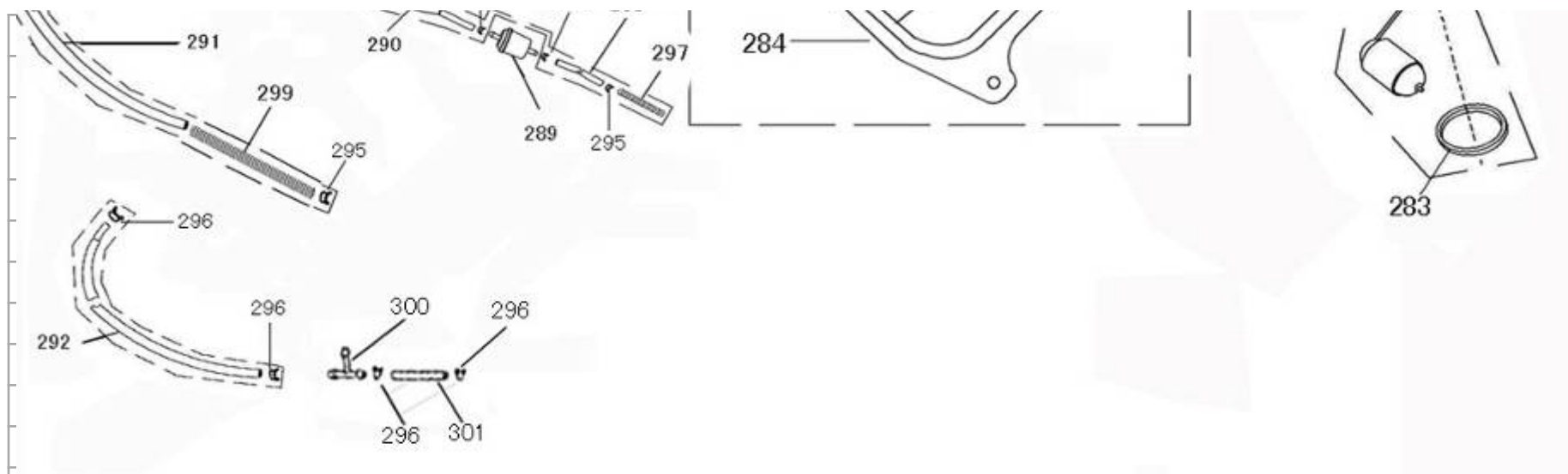

ZN150T-H(PK150T-BEETLE) 零部件图册 F10

页码	区分					部品编号	部品名称(英)	部品名称(中)	数量	版次	仓库号	设变记事	设变日期
	主	附	细	细	细								
F10	280					3780A-DGW-9000	FUEL UNIT ASSY	油位传感器总成	1		B		
F10		281				37800-DGW-9000	FUEL UNIT	油位传感器	1		B		
F10		282				37802-F8-9000	RET FUEL UNIT	传感器压板	1		B		

ZN150T-H(PK150T-BEETLE) 零部件图册 F11

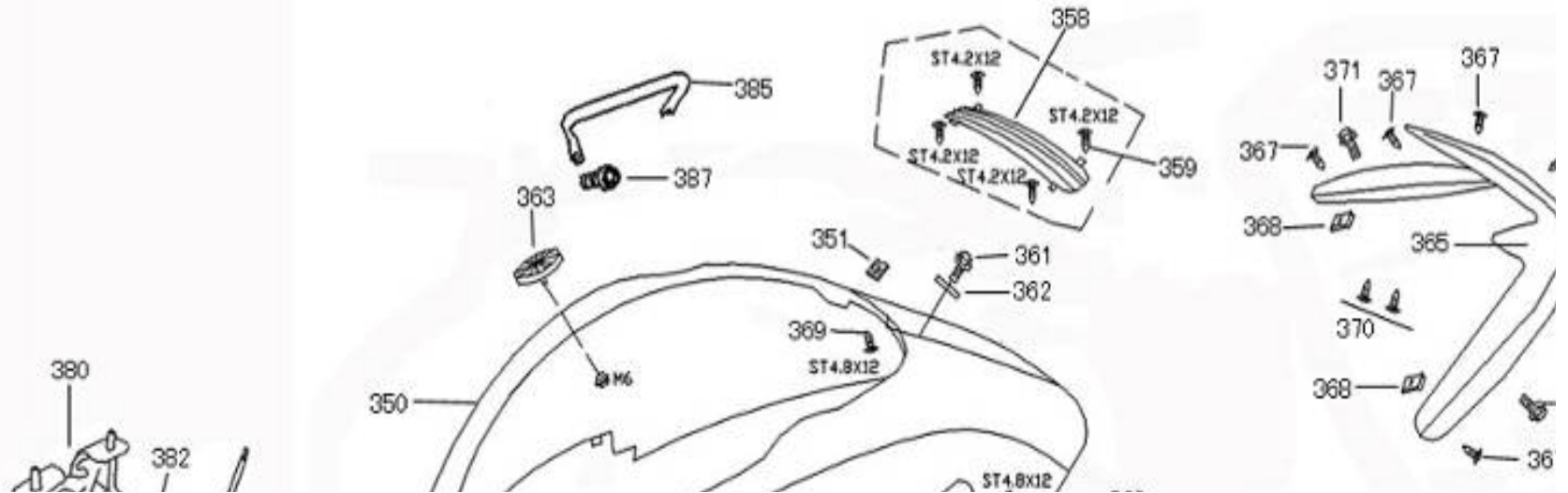

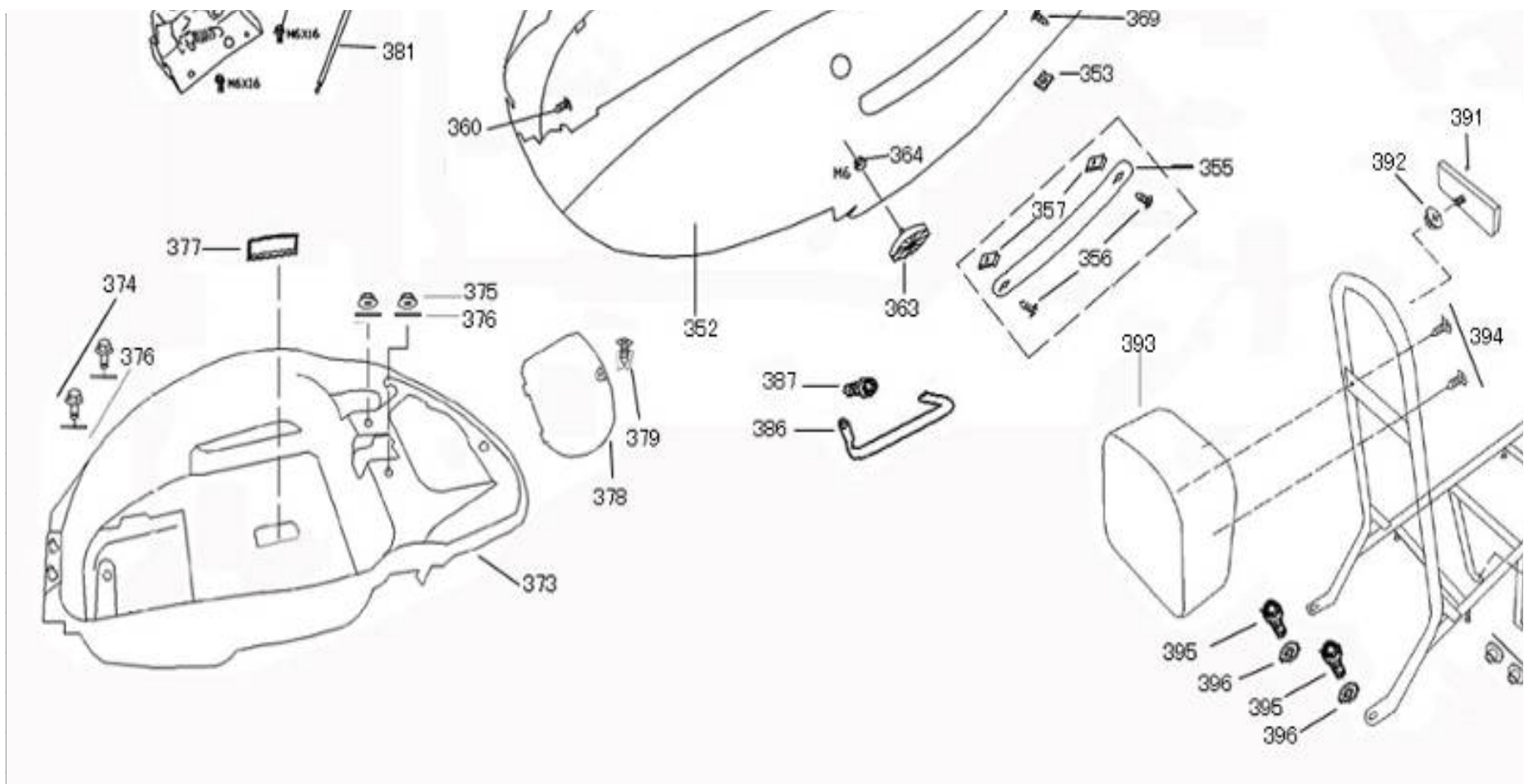

ZN150T-H(PK150T-BEETLE) 零部件图册 F13

页码	区 分					部品编号	部品名称(英)	部品名称(中)	数量	版次	仓库号	设变记 事	设变 日期
	主	附	细	细	细								
F13	350					83500-DGW2-900	COVER R BODY	右装饰板	1		D	15	
F13	351					90701-06000-03	NUT CLIP 6MM	6MM卡片	1		H		
F13	352					83600-DGW2-900	COVER L BODY	左装饰板	1		D	15	
F13	353					90701-06000-03	NUT CLIP 6MM	6MM卡片	1		H		
F13	355					83602-DGW2-900	Left trim	左后装饰条	1		D	2	
F13	356					93401-48016-03	SCREW TAPPING	左后装饰条螺丝 (军绿)	2		H		
F13	357					90601-F8-9000	NUT SPRING 4M	4MM卡片	2		H		
F13	358					83752-DGW2-900	WINDAGE CLAI	装饰板后通风隔	1		A		
F13	359					93401-42012-03	SCREW TAPPING	通风隔螺丝 (军绿)	4		H		
F13	360					93401-42010-03	SCREW TAPPING	装饰板结合螺丝 (军绿)	1		H		
F13	361					92702-06016-03	SCREW SPECIAL	装饰板锁付螺丝	1		H		
F13	362					43434-F8-9000	FR. COVER RUB	橡皮垫	1		B		
F13	363					33741-F8-E000	REFLEX REFLEC	侧反射片(黄色)	2		A		
F13	364					90201-06000-03	NUT FLANGE 6M	侧反射片螺帽	2		A		
F13	365					83757-DGW2-900	TAIL DEC.UPPE	尾装饰板上部	1		A		
F13	366					83758-DGW2-900	TAIL DEC.UNDE	尾装饰板下部	1		A		
F13	367					93401-42012-03	SCREW TAPPING	尾装饰板结合螺丝 (军绿)	8		H		
F13	368					90601-F8-9000	NUT SPRING 4M	4MM卡片	2		H		
F13	369					93401-48012-03	SCREW TAPPING	尾装饰板与装饰板结合螺丝	2		H		

F13	370			93401-42012-03	SCREW TAPPING	尾装饰板与装饰板结合螺丝	2		H		
F13	371			92101-06016-03	BOLT FLANGE 6	尾装饰板与装饰板结合螺丝	2		H		
F13	372			92101-06012-03	BOLT FLANGE 6	装饰板与车架锁付螺丝	2		H		
F13	373			81250-DGW2-900	BOX LUGGAGE	行李箱组	1		A		
F13	374			92101-06012-03	BOLT FLANGE 6	行李箱锁付螺丝	2		H		
F13	375			95201-06000-03	NUT FLANGE 6M	行李箱锁付螺帽	2		H		
F13	376			95801-06000-03	WANSHER 6MM	6MM垫片	4		H		
F13	377			81254-DGW-9000	COVER BOX LU	行李箱小盖(同号码盖)	1		A		
F13	378			81259-DGW2-900	COVER ASSY CA	行李箱后盖	1		A		
F13	379			90004-DGW2-900	CLIP BODY COV	塑胶膨胀螺丝	1		A		
F13	380			77235-DGW-9000	SEAT CATCH CO	座垫锁组件	1		M		
F13	381			77240-DGW-9000	CABLE SEAT LO	座垫锁拉线	1		B		
F13	382			92101-06016-03	BOLT FLANGE 6	座垫锁锁付螺丝	2		H		
F13	385			50171-DGW-9000	BRKT R SIDE GR	右拉手	1		M		
F13	386			50172-DGW-9000	BRKT L SIDE GR	左拉手	1		M		
F13	387			92501-06020-03	BOLT SPECIAL 8	拉手螺丝	2		H		

F13

F13

F13

F13

F13

F13

F13

F13

F13

F13

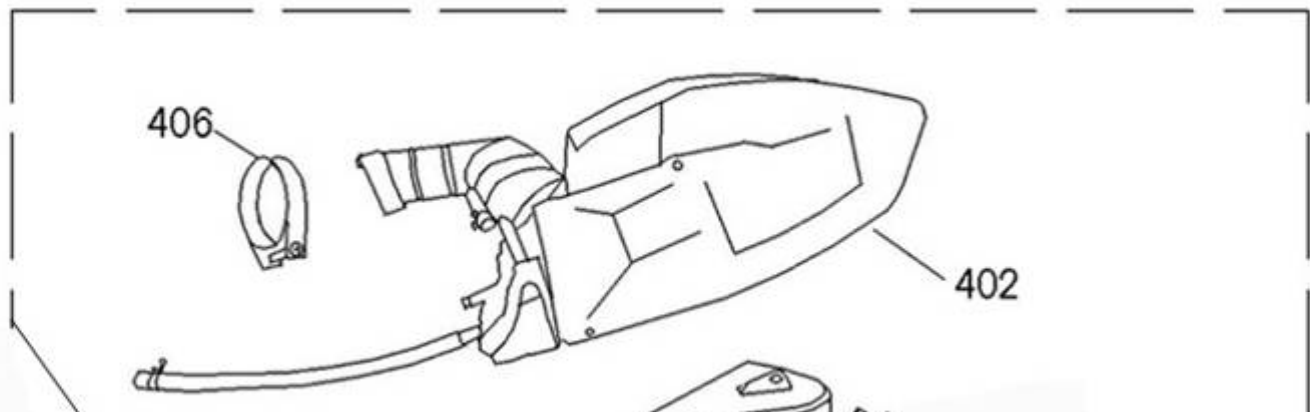

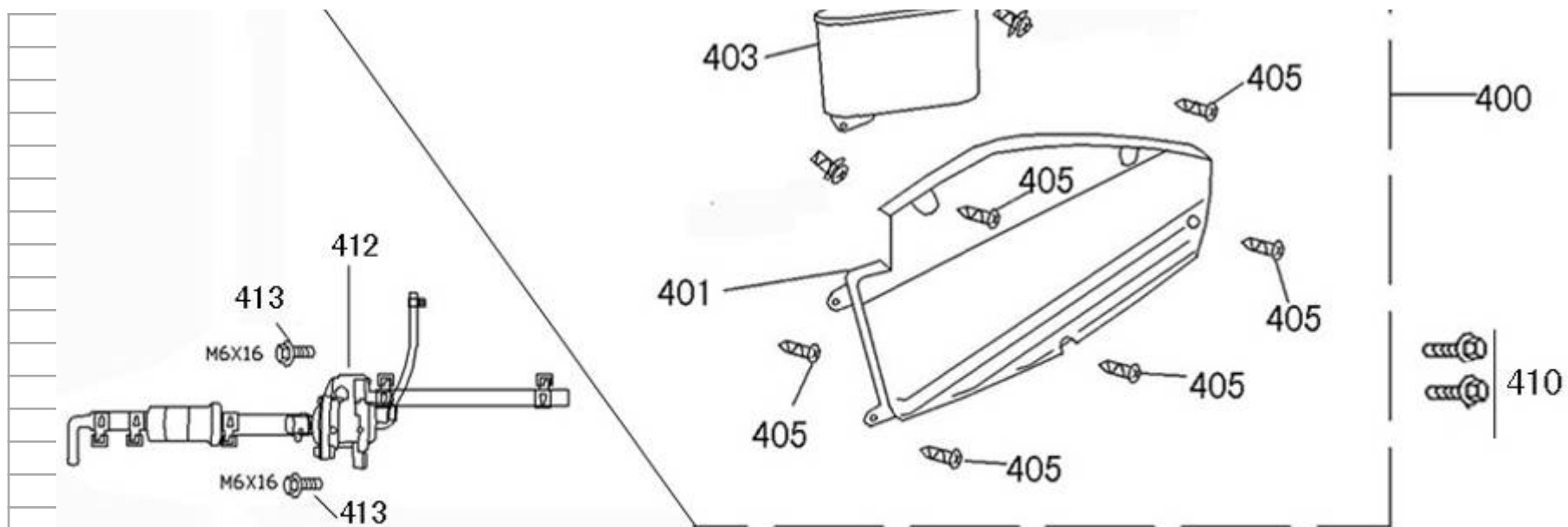

页	区分						设变记	设变日期
F1								
F1								
F1								
F1								
F1								
F1								
F1								
F1								
F1								
F1								
F1								
F1								
F1								
F1								
F1								
F1								
F1								

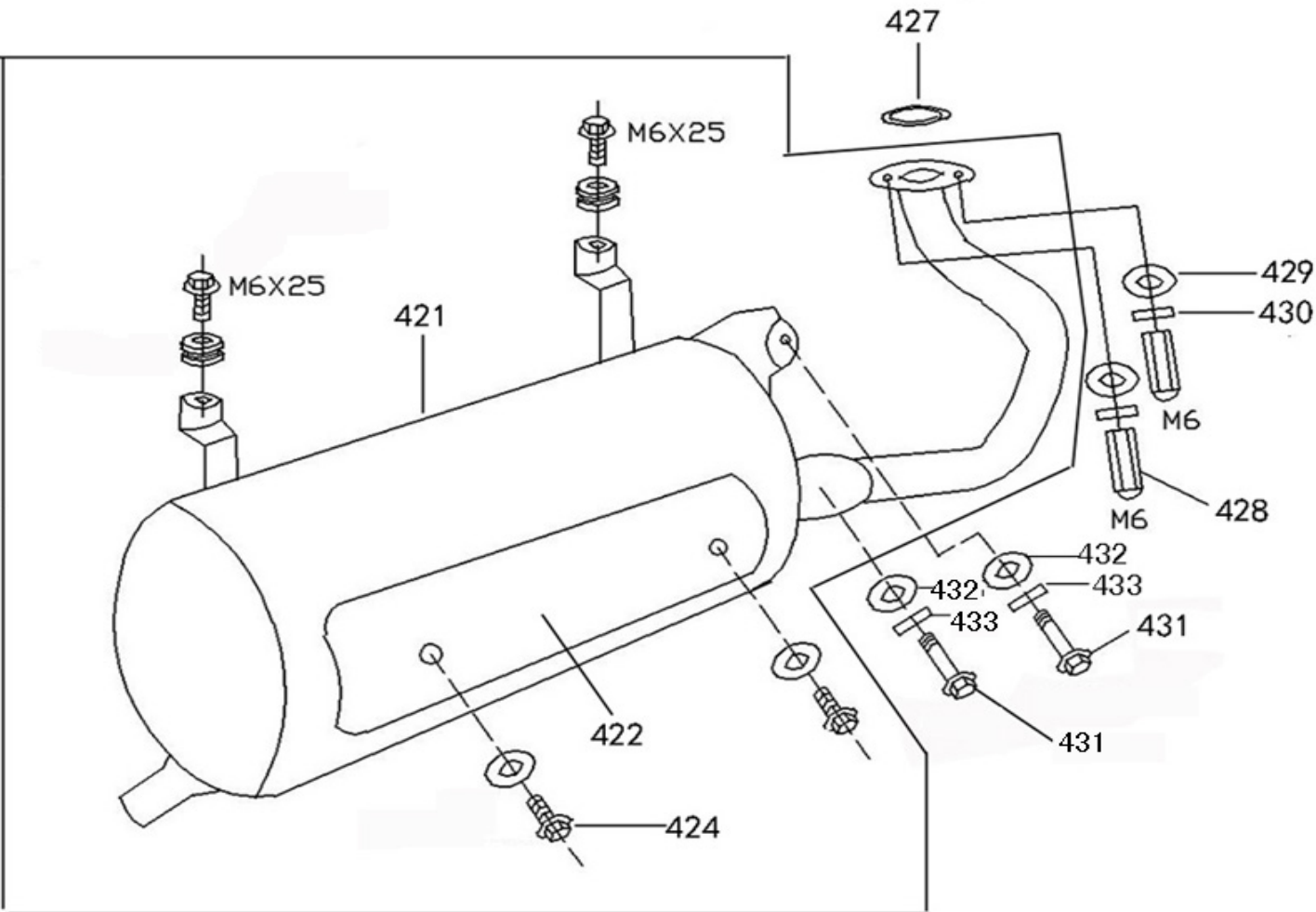

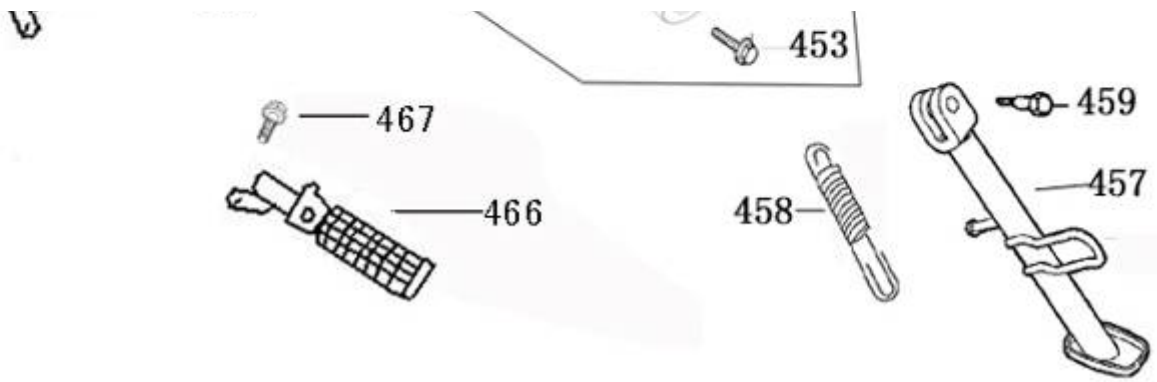

ZN150T-H(PK150T-BEETLE) 零部件图册 F16

页码	区分				部品编号	部品名称(英)	部品名称(中)	数量	版次	仓库号	设变记事	设变日期
	主	附	细	细								
F16	451				50500-DGW-9000	STAND COMP M	主脚架	1		M		
F16	452				50505-F8-9000	STOPPER RUBB	主脚架制止橡皮	1		B		

F16	453		
F16	454		
F16	455		
F16	456		
F16	457		
F16	458		
F16	459		
F16	465		
F16	466		
F16	467		

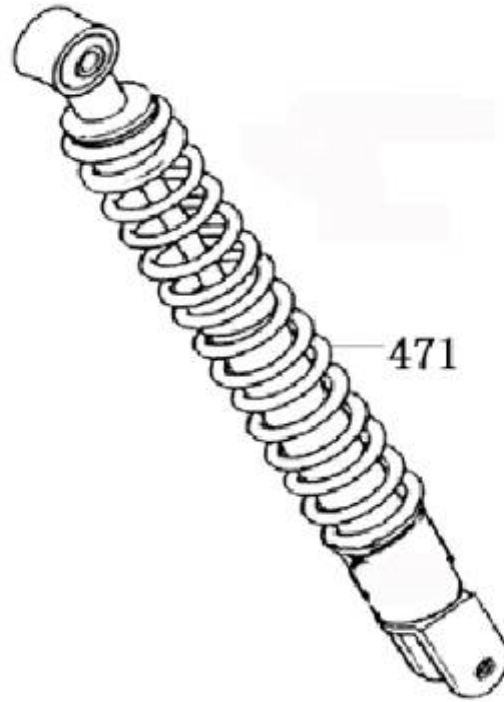
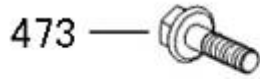

	H		
	H		
	H		
	G		
	M		
	H		
	G		
	M		
	M		
	H		



页码	区 号		
	主	附	细
F17	471		
F17	472		
F17	473		

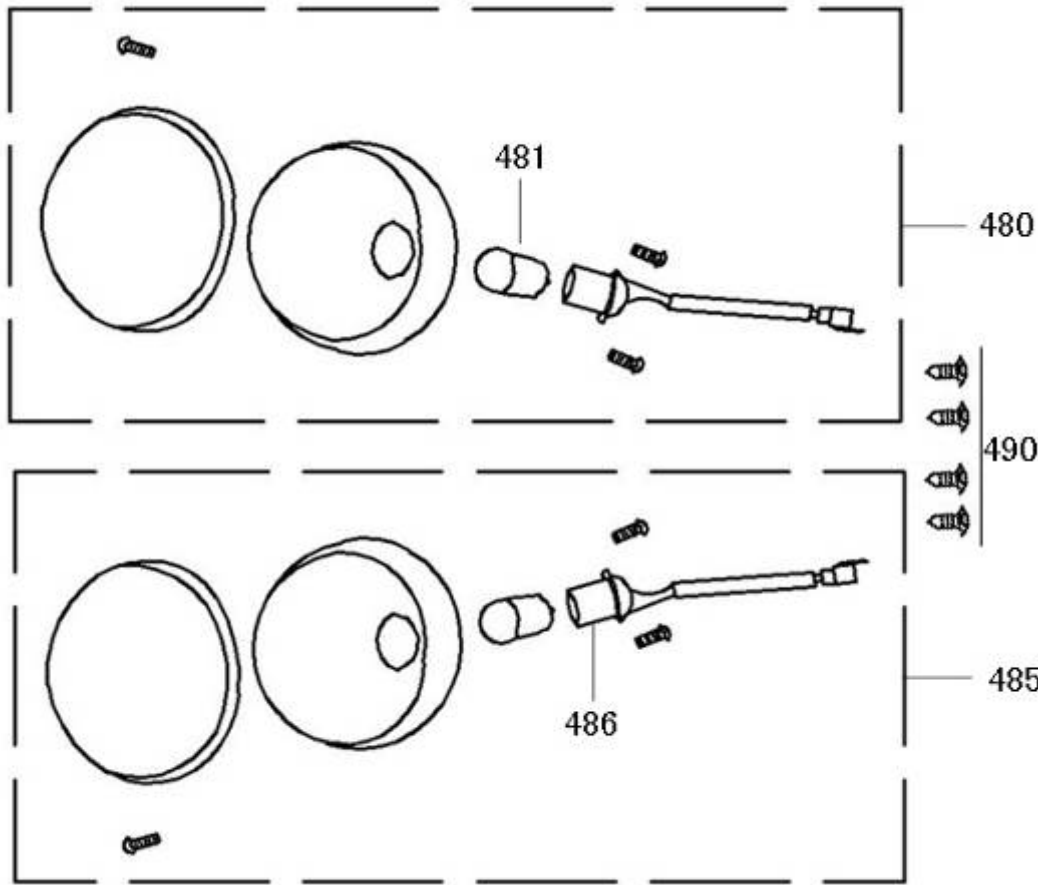

册 F17

页次	仓库号	设变记事	设变日期
	G		
	H		
	H		



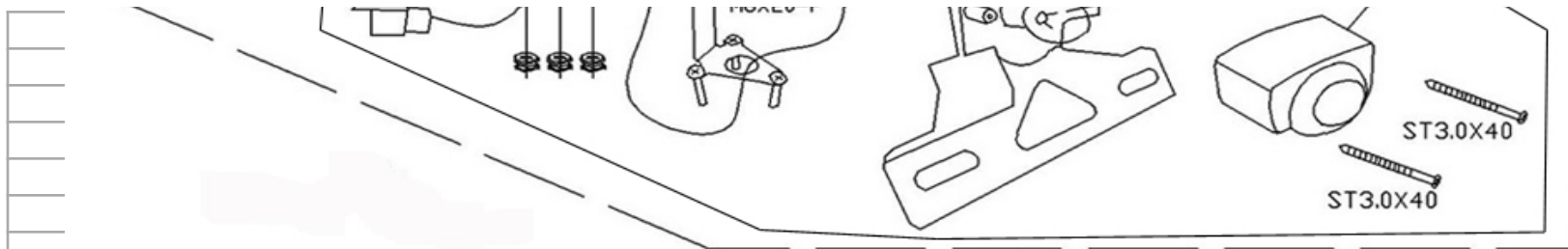

ZN150T-H(PK150T-BEETLE) 零部件图册 F19

页码	区分					部品编号	部品名称(英)	部品名称(中)	数量	版次	仓库号	设变记事	设变日期
	主	附	细	细	细								
F19	500					3370A-DGW-9000	COMP LIGHT RR	尾灯总成	1		B		
F19		50				33700-DGW-9000	LIGHT ASSY RR	尾灯组	1		B		
F19			50			34960-F8-9000	BULB TAIL LIGH	尾灯灯泡 (12V 21W/5W)	1		B		

F19		50		33702-DGW-9000	LENS COMP TAI	尾灯壳	1		B		
F19		~		33704-DGW-9000	BASE COMP RR	尾灯反射面总成	1		B		
F19		~		33707-DGW-9000	SOCKET COMP	插座	1		B		
F19		~		33710-DGW-9000	STAY RR LIGHT	尾灯支架	1		B		
F19		~		93201-06020-09	SCREW PAN 6*2	尾灯支架螺丝 (不锈钢)	2		B		
F19		~		95801-06103	WANSHER 6MM	垫片 (不锈钢)	2		B		
F19		~		95901-06202	SPG WANSHER	弹簧垫片 (不锈钢)	2		B		
F19		51		33600-DGW-9000	WINKER ASSY R	右后转向灯	1		B		
F19		51		34905-F8-9000	BULB WINKER	方向灯泡	1		B		
F19		~		33602-DGW-9000	LENS R FR WIN	右后方向灯壳	1		B		
F19		~		33603-DGW-9000	BASE R FR WIN	右后方向灯座	1		B		

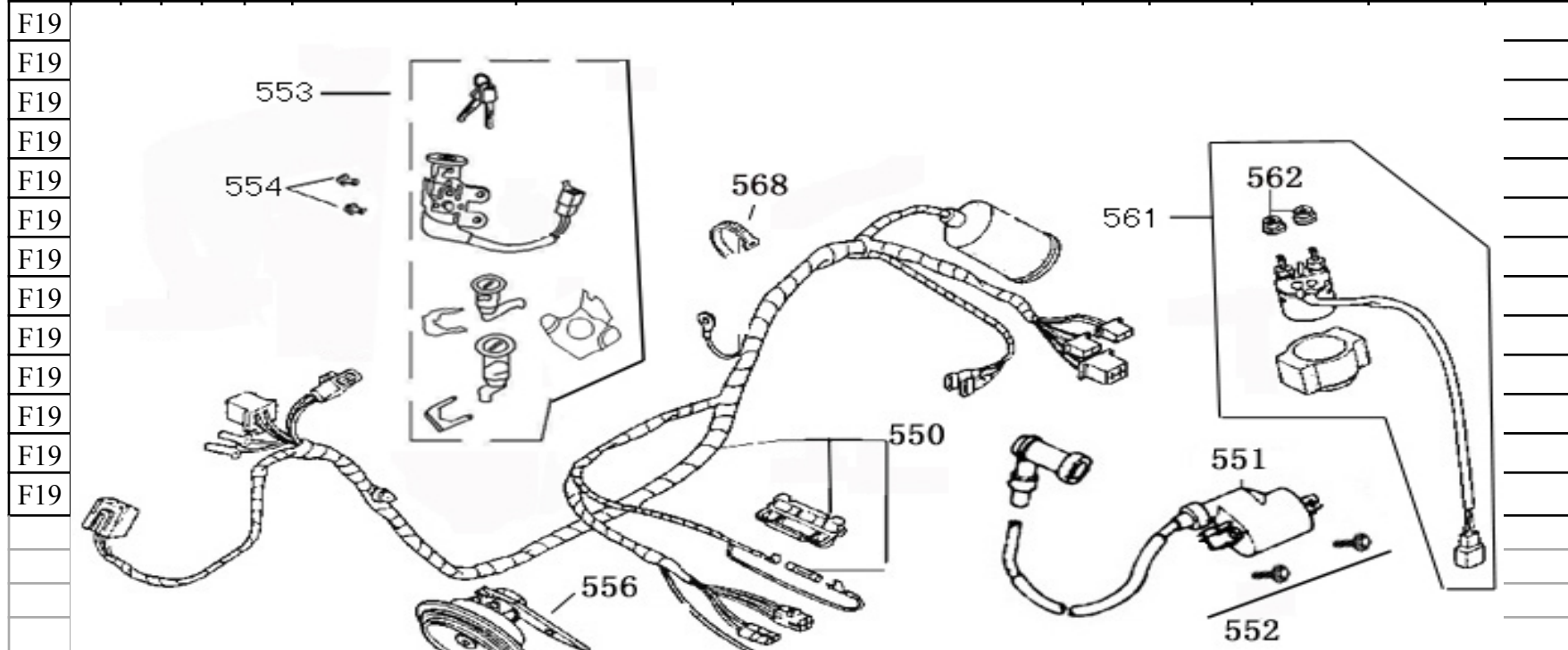

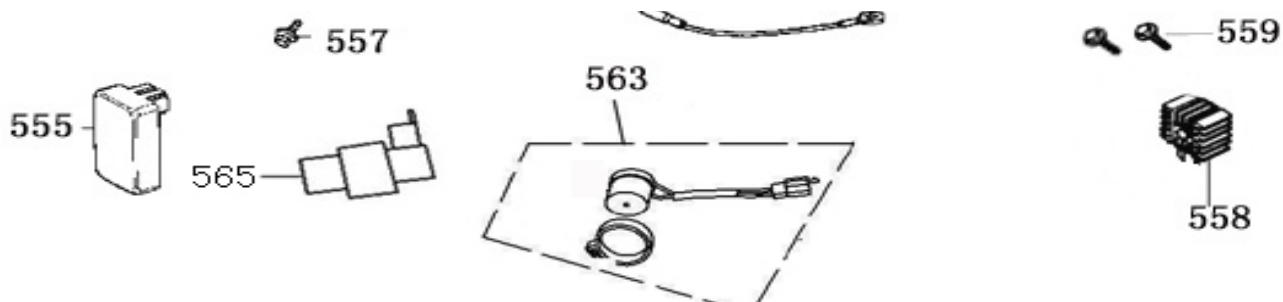

ZN150T-H(PK150T-BEETLE) 零部件图册 F20

页码	区分					部品编号	部品名称(英)	部品名称(中)	数量	版次	仓库号	设变记事	设变日期
	主	附	细	细	细								
F20	◎					0035Z-DGW-9000	ILLUS WIREING	配线图	M		/		
F20	550					32100-DGW-E000	HARNESS WIRE	主电缆	1		E		

F20	~		38205-XF-9000	CASE FUSE	保险丝盒	1		E		
F20	~		99200-11500	FUSE 15A	保险丝	2		E		
F20	~		38205-XF-9000	CASE FUSE	保险丝盒	1		E		

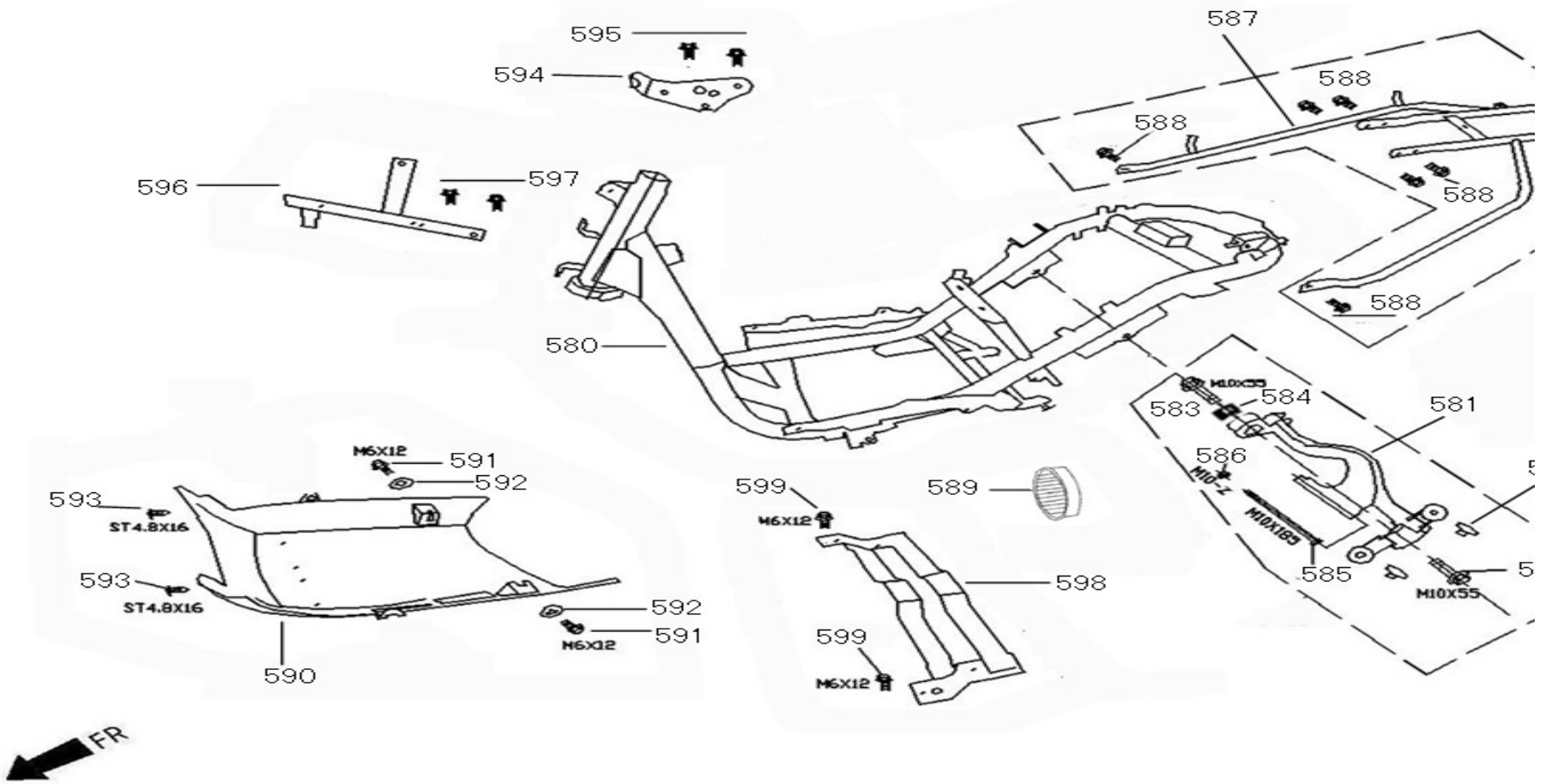

ZN150T-H(PK150T-BEETLE) 零部件图册 F27

页码	区 分				部品编号	部品名称(英)	部品名称(中)	数量	版次	仓库号	设变记 事	设变 日期
	主	附	细	细								
F27	721				89010-F8-9000	TOOL SET	工具包组(选配)	1		C		
F27	722				88140-F8-9000	SW FLAMEOUT	侧支架熄火开关(选配)	1		B		
F27	723				92101-06016-03	BOLT FLANGER	侧支架熄火开关螺丝(选配)	1		H		
F27	724				92101-08030-03	BOLT FLANGER	侧支架熄火开关限位螺丝(选	1		H		
F27	730				88130-F8-9000-A/	BURGLAR ALAR	防盗器(选配)	1		B		
F27	731				88139-ZNW-9000	ALARM PRESS E	防盗器压板(选配)	1		F		
F27	732				92101-06016-03	BOLT FLANGER	防盗器压板螺丝(选配)	2		H		
F27	733				93401-42016-03	SCREW TAPPIN	防盗器喇叭螺丝(选配)	2		H		
							发动机					
							化油器 (德利)					

	2										
											
											
											
											
											
											
											
											
											
											

备注	单价										
	\$2.34										
	\$2.34										
	\$0.70										
	\$0.45										
	\$0.45										
	\$2.25										
	\$2.25										
	\$4.84										
	\$2.49										
	\$1.08										
	\$0.10										
	\$1.08										
	\$0.20										
	\$3.78										
	\$1.53										
	\$1.17										
	\$0.18										
	\$0.36										
	\$0.36										
	\$0.18										
	\$0.72										
	\$0.09										



124

	\$0.80										
	\$0.05										
	\$2.77										
	\$0.21										
	\$0.21										
	\$0.02										
	\$3.20										
	\$0.08										
	\$0.08										
	\$0.64										
	\$0.43										
	\$0.02										
	\$0.01										
	\$0.02										
	\$0.85										
	\$0.04										
	\$1.28										
	\$1.28										
	\$0.08										
	\$0.04										
	\$0.04										
	\$2.99										
	\$2.99										
	\$0.04										
	\$0.04										
	\$2.07										
	\$0.14										
	\$0.58										
	\$2.07										

	\$1.49											
	\$1.49											
	\$0.80											
	\$0.30											
	\$0.02											
	\$1.53											
	\$1.53											
	\$0.32											
	\$0.20											
	\$0.32											
	\$0.20											
	\$0.40											
	\$1.26											
	\$0.18											
	\$0.18											
	\$0.18											
	\$0.18											
	\$0.18											
	\$0.18											
	\$0.18											
	\$1.08											
	\$0.18											
	\$0.18											
	\$0.18											
	\$0.18											
	\$0.18											
	\$0.18											
	\$0.09											

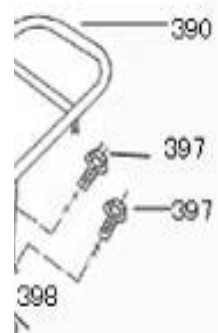

	\$1.80										
	\$1.80										
	\$0.36										
	\$0.36										
	\$0.04										
	\$0.04										
	\$0.04										
	\$1.26										
	\$0.27										
	\$0.27										
	\$0.36										
	\$0.36										
	\$1.26										
	\$0.27										
	\$0.27										
	\$0.36										
	\$0.36										
	\$1.44										
	\$1.28										
	\$0.02										
	\$0.02										
	\$0.02										
	\$0.15										
	\$0.30										

