



***TrailMaster* GO-KART**

300 XRX

PARTS MANUAL

Version: 2 (9/19/2011)

FIG. 1 LEFT CRANKCASE COMP.

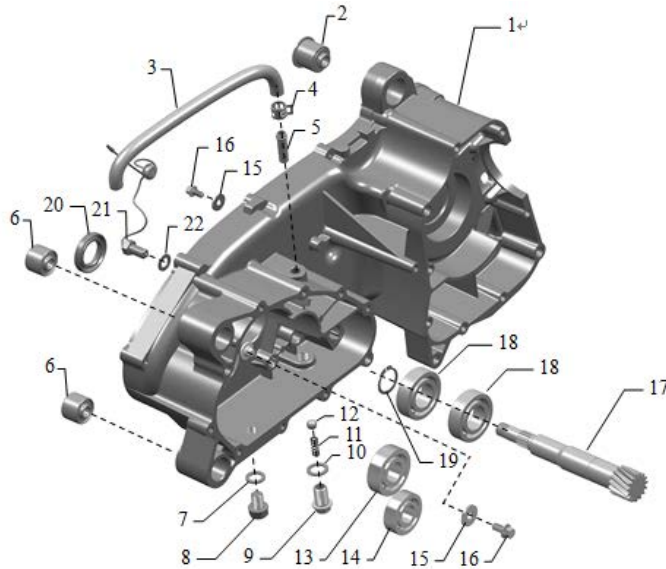

LEFT CRANKCASE COMP.			
REF NO.	PART NO.	DESCRIPTION	QTY
1-1	169-4.03.111	LEFT CRANKCASE	1
1-2	169.12.104	FRONT ABSORBER BUSING SET	1
1-3	157-3.12.159	GEARBOX AIR TUBE	1
1-4	157-3.11.410	SNAP RING	1
1-5	157-3.03.615	TUBE CONNECTOR	1
1-6	157-3.12.105	REAR ABSORBER BUSHING SET	2
1-7	139.11.822	WASHER (AL) 12X20X1.5	1
1-8	152.11.306	FLANGE BOLT M12X1.5	1
1-9	157-3.11.307	TRANSMISSION HUB POSITIONING BOLT	1
1-10	157-3.11.834	WASHER (AL) 14X22X1.3	1
1-11	157-3.10.829	TRANSMISSION HUB POSITIONING SPRING	1
1-12	GB/T308 10	STEEL BALL S Φ 10.319	1
1-13	GB/T 276 6203	BALL BEARING 6203	1
1-14	GB/T 276 6202	BALL BEARING 6202	1
1-15	157-3.11.858	WASHER (ST) 6X18X1.8	2
1-16	GB/T16674.1	FLANGE BOLT M6X12	2
1-17	169-4.10.411	INPUT SHAFT	1
1-18	GB/T 276 6205	BALL BEARING 6205	2
1-19	GB/T894.1-A 25	SNAP RING FOR SHAFT 25	1
1-20	169.12.412	OIL SEAL 25X42X7	1
1-21	157-3.10.823	IDLE PARTS	1
1-22	157-3.11.849	WASHER (AL) 10X18X1.3	1

FIG. 2

RIGHT CRANKCASE COMP.

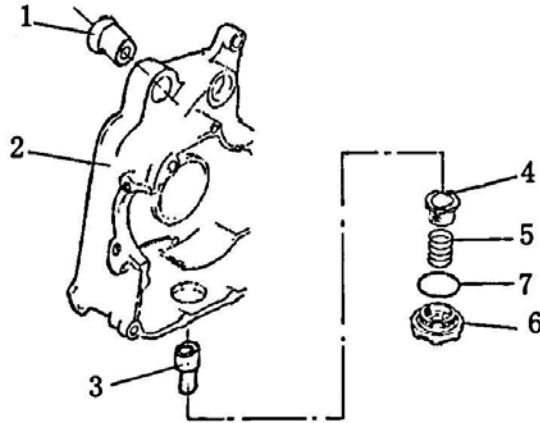

RIGHT CRANKCASE COMP.			
REF NO.	PART NO.	DESCRIPTION	QTY
2-1	169.12.104	FRONT ABSORBER BUSHING SET	1
2-2	169.03.211	RIGHT CRANKCASE	1
2-3	169.09.414	FILTER OIL TUBE	1
2-4	169.09.412	FILTER ELEMENT	1
2-5	169.09.413	FILTER SPRING	1
2-6	169.09.411	FILTER COVER	1
2-7	169.12.524	O-RING 36X3.5	1

FIG. 3
PARTS OF PISTON, BRANCE, LEFT AND RIGHT
CRANKCASE

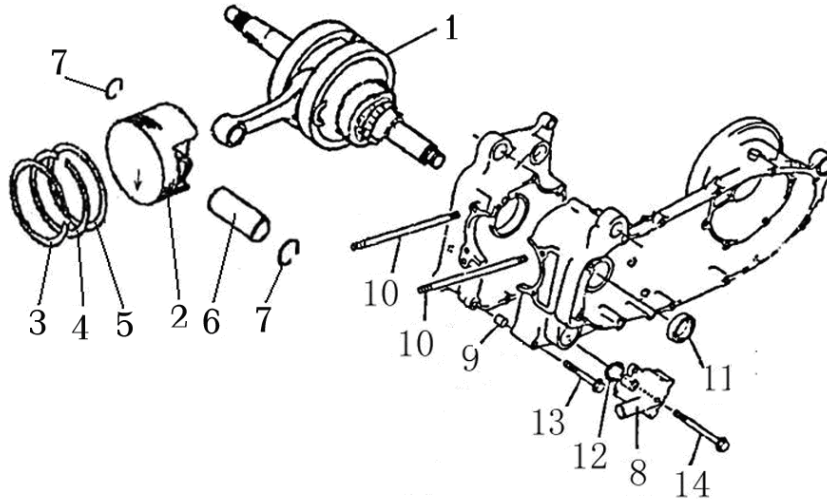

PARTS OF PISTON, BRANCE, LEFT AND RIGHT			
CRANKCASE			
REF NO.	PART NO.	DESCRIPTION	QTY
3-1	169-4.01.110	BRANCE	1
3-2	169.01.311	PISTON	1
3-3	169.01.321	FIRST RING	1
3-4	169.01.322	SECOND RING	1
3-5	169.01.323	OIL RING ASSY.	1
3-6	169.01.312	PISTON PIN	1
3-7	169.01.313	PISTON PIN CIRCLIP	2
3-8	169.05.410	WATER PUMP COMP.	1
3-9	157-3.11.508	PIN 10X14	2
3-10	169.11.215	DOUBLE-SCREW LONG BOLT	4
3-11	169.12.416	OIL SEAL 30X45X5	1
3-12	169.12.522	O-RING 33.5X2.65	1
3-13	GB/T 16674.1 M6×70	BOLT M6X70	4
3-14	GB/T 16674.1 M6×100	BOLT M6X100	5
(3-15)	169.01.320	PISTON RING COMP. (3-3, 4, 5)	1
(3-16)	169.01.321	PISTON COMP. (3-2,3,4,5)	1

FIG. 4
CYLINDER HEAD COMP.

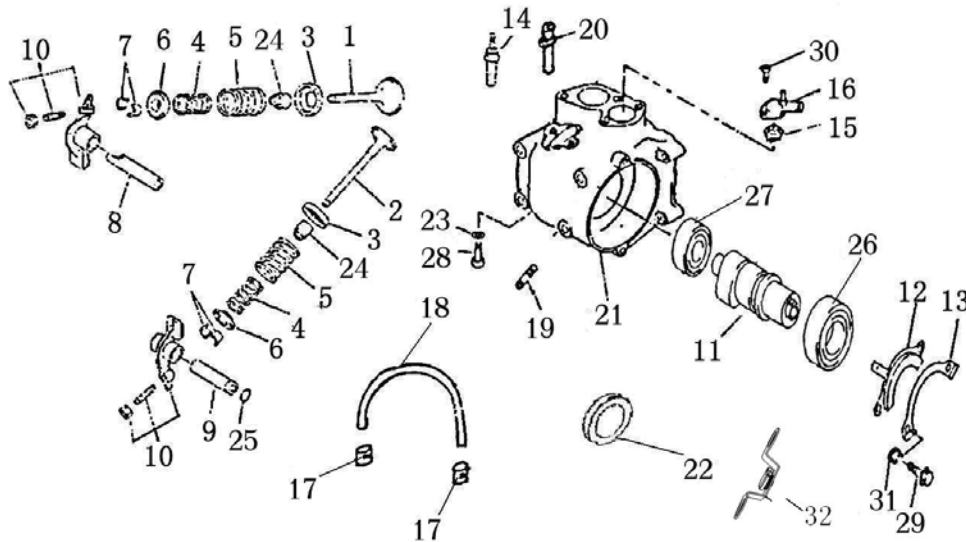

CYLINDER HEAD COMP.			
REF NO.	PART NO.	DESCRIPTION	QTY
4-1	169.02.311	INTAKE VALVE	1
4-2	169.02.312	EXHAUST VALVE	1
4-3	169.02.315	LOWER VALVE SPRING SEAT	2
4-4	169.02.313	INSIDE VALVE SPRING	2
4-5	169.02.314	OUTSIDE VALVE SPRING	2
4-6	169.02.315	UPPER VALVE SPRING SEAT	2
4-7	169.02.317	VALVE LOCKING CIRCLIP	4
4-8	169.02.112	INTAKE ARM SHAFT	1
4-9	169.02.113	EXHAUST ARM SHAFT	1
4-10	169.02.120	ARM COMP.	2
4-11	169.02.210B	CAM SHAFT	1
4-12	169.11.120	CAM SHAFT CLAMP	1
4-13	169.11.121	CLAMP OUTSIDE SPACER	1
4-14	169.05.712	WATER TEMPERATURE INDUCTOR	1
4-15	169.05.720	THERMOSTAT COMP.	1
4-16	169.05.730	THERMOSTAT COVER COMP.	1
4-17	152.11.407	SMALL WATER TUBE CIRCLIP	2
4-18	169.12.201	SMALL WATER TUBE	1
4-19	169.11.210	EXHAUST TUBE DOUBLE-SCREW BOLT	2
4-20	169.04.223	SMALL WATER CONNECTOR	1
4-21	169.04.210B	CYLINDER HEAD MECH. COMP.	1

4-22	169.08.490	EXHAUST TUBE SEAL GASKET	1
4-23	169.11.801	OIL PRESSURE INDICATOR COPPER WASHER	1
4-24	169.12.402	VALVE STEM OIL SEAL	2
4-25	169.12.507	O-RING 9X2	1
4-26	GB/T 276 6005	BALL BEARING	1
4-27	GB/T 276 6202-RS	BALL BEARING	1
4-28	GB/T 5789 M6×12	BOLT M6X12	1
4-29	GB/T 16674.1 M6×12	BOLT M6X12	2
4-30	GB/T16674.1 M6×20	BOLT M6X20	2
4-31	GB/T859 6	SPRING WASHER	2
4-32	169.02.130	ONE-WAY STOP DEVICE	1
(4-33)	169.02.200B	CAM SHAFT COMP. (INCL.11, 26, 27)	1

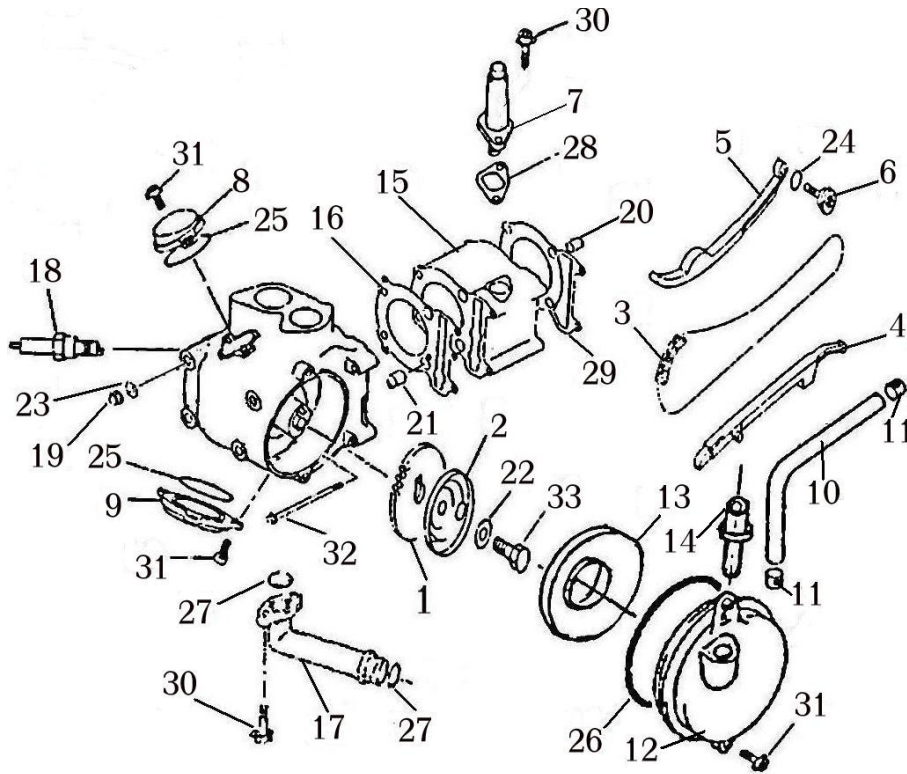
FIG. 5**CYLINDER / TIMING CHAIN DRIVER / VALVE COVER**

CYLINDER / TIMING CHAIN DRIVER / VALVE COVER			
REF NO.	PART NO.	DESCRIPTION	QTY
5-1	169.02.212	TIMING DRIVEN SPROCKET	1
5-2	169.04.261	SPROCKET COVER	1
5-3	169.02.510	TIMING CHAIN	1
5-4	169.02.710	CHAIN GUIDING PLATE	1
5-5	169.02.610	TENSIONING PLATE	1
5-6	169.02.506	TENSIONING PLATE SCREW	1
5-7	169.02.410	TENSIONING DEVICE COMP.	1
5-8	169.02.221	INTAKE VALVE COVER	1
5-9	169.02.222	EXHAUST VALVE COVER	1
5-10	169.12.158	SPROCKET ROOM COVER AIR TUBE	1
5-11	169.11.411	TUBE CIRCLIP	2
5-12	169.04.261	SPROCKET ROOM COVER	1
5-13	169.11.124	BREATHER PLATE	1
5-14	169.04.312	BREATHER PIPE CONNECTOR	1
5-15	169.04.110	CYLINDER	1

5-16	169.12.319	CYLINDER HEAD SPACER COMP.	1
5-17	169.05.711	PUMP DISCHARGE ELBOW	1
5-18	169.07.210	SPARKING PLUG	1
5-19	169.11.313	COVER BOLT M8	4
5-20	157-3.11.508	PIN 10X14	2
5-21	169.11.509	PIN 14X16	2
5-22	169.11.806	SPROCKET SPACER 10X22X2.5	1
5-23	169.11.811	CYLINDER HEAD COPPER SPACER 8X18X2	4
5-24	169.12.514	O-RING 14.5X1.8	1
5-25	169.12.526	O-RING 57.5X2.3	2
5-26	169.12.527	O-RING 94X3.3	1
5-27	169.12.516	O-RING 15.5X2.5	2
5-28	169.12.306	TENSIONING DEVICE SPACER	1
5-29	169.12.304	CYLINDER PAPER SPACER	1
5-30	GB/T16674.1 M6×16	BOLT M6X16	4
5-31	GB/T16674.1 M6×20	BOLT M6X20	7
5-32	GB/T16674.1 M6×120	BOLT M6X120	2
5-33	GB/T5786 M10×1.25×25	BOLT M10X1.25X25	1
(5-34)	169.02.800	SPROCKET ROOM COVER COMP. (5-12,13,14,26)	1

FIG. 6

**RIGHT COVER / MAGNETOR / ENGINE OIL PUMP /
PUMP / ELECTRIC START DRIVING**

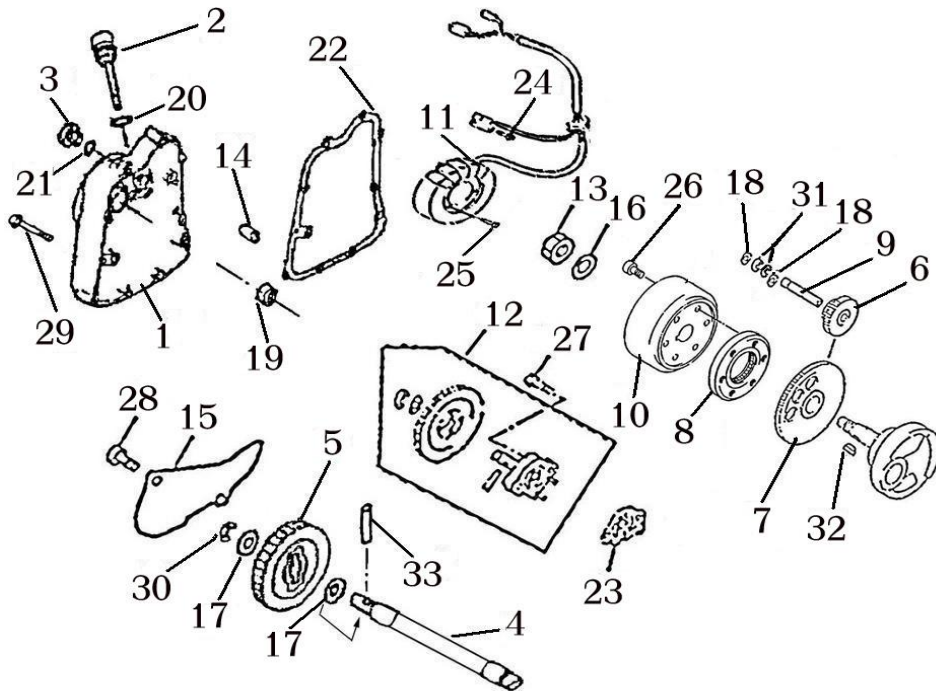

RIGHT COVER / MAGNETOR / ENGINE OIL PUMP / PUMP / ELECTRIC START DRIVING			
REF NO.	PART NO.	DESCRIPTION	QTY
6-1	169.03.411	RIGHT COVER	1
6-2	169.09.415	OIL GAUGE	1
6-3	169.03.412	PEEP DOOR SCREW PLUG	1
6-4	169.05.511	PUMP DRIVE SHAFT	1
6-5	169.05.512	PUMP GEAR	1
6-6	169.06.260	ELECTRIC START INTERMEDIATE GEAR COMP.	1
6-7	IN 169.06.310	FREE-WHEELING CLUTCH INNER RING	1
6-8	IN 169.06.310	FREE-WHEELING CLUTCH OUTER RING COMP.	1
6-9	169.06.271	INTERMEDIATE GEAR SHAFT	1
6-10	IN 169.07.110	MAGNETOR FLYING WHEEL	1
6-11	IN 169.07.110	MAGNETOR STATOR	1
6-12	169.09.110	ENGINE OIL PUMP COMP.	1

6-13	169.11.313	CRANKCASE RIGHT SIDE NUT M16X1	1
6-14	157-3.11.508	PIN 10X14	2
6-15	169.11.204	COVER PLATE	1
6-16	169.11.843	CRANKCASE RIGHT SIDE SPACER	1
6-17	169.11.859	PUMP GEAR SPACER	2
6-18	169.11.818	ELECTRIC START INTERMEDIATE SHAFT SPACER	2
6-19	169.12.403	RIGHT COVER CAMSHAFT OIL SEAL	1
6-20	169.12.517	O-RING 18X2.65	1
6-21	169.12.513	O-RING 14X2.65	1
6-22	169.12.302	RIGHT COVER PAPER SPACER	1
6-23	169.12.311	ENGINE OIL PUMP PAPER SPACER	1
6-24	GB/T 70.1 M5×12	SCREW M5×12	2
6-25	GB/T 70.1 M5×25	SCREW M5×25	3
6-26	GB/T 70.1 M8×18	SCREW M8×18	3
6-27	GB/T70.2 M6×25	SCREW M6×25	2
6-28	GB/T16674.1 M6×16	BOLT M6×16	2
6-29	GB/T16674.1 M6×40	BOLT M6×40	10
6-30	GB/T894.1 8	SNAP RING FOR SHAFT 8	1
6-31	GB/T 894.1 12	SNAP RING FOR SHAFT 12	2
6-32	GB/T1099.1 5×5.5×16	WOODRUFF KEY 5×5.5×16	1
6-33	GB/T119 B3×22	PIN B3X22	1
(6-34)	169.03.600	RIGHT CRANKCASE COVER COMP. (6-1,2,3,11,19,20,21,24,25)	1
(6-35)	169.05.410	PUMP COMP. (6-4,5,17,30,33)	1
(6-36)	169.06.310	FREE-WHEELING CLUTCH COMP. (6-7,8)	1
(6-37)	169.07.110	MAGNETOR COMP. (6-10,11)	1

FIG. 7
V-BELT DRIVING

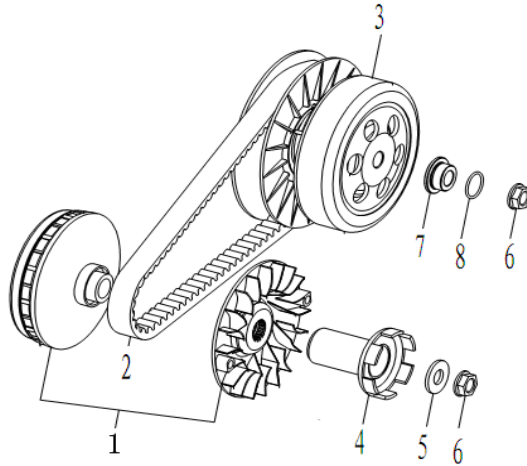

V-BELT DRIVING			
REF NO.	PART NO.	DESCRIPTION	QTY
7-1	169.10.110	DRIVE COMP.	1
7-2	169.10.310	V BELT	1
7-3	169.10.210	CLUTCH, DRIVEN PULLEY COMP.	1
7-4	152.03.323	HAND STARTING PART	1
7-5	157-3.11.838	WASHER 15	1
7-6	169.11.312	FLANGE BOLT M14X1	2
7-7	169.10.412	CLUTCH BRACKET BUSHING	1
7-8	139.12.520	O-RING 21X2	1

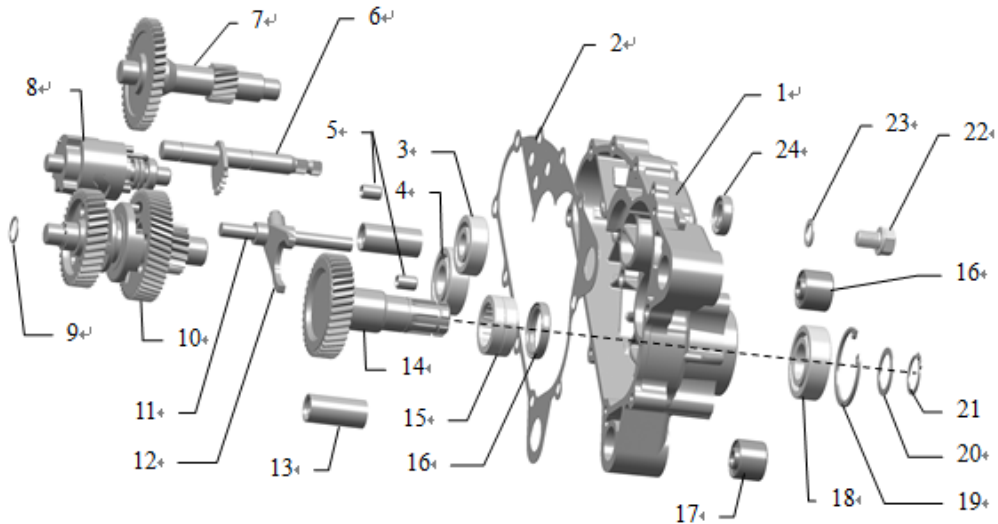
FIG. 8**GEARBOX DRIVING****GEARBOX DRIVING**

REF NO.	PART NO.	DESCRIPTION	QTY
8-1	157-3.03.501	GEARBOX COVER	1
8-2	157-3.12.305	GEARBOX COVER SPACER	1
8-3	GB/T276 6302	BALL BEARING 6302	1
8-4	GB/T276 6204	BALL BEARING 6204	1
8-5	157-3.11.508	PIN Ø10×14	2
8-6	157-3.10.760	TRANSMISSION SHAFT COMP.	1
8-7	157-3.10.710	REVERSE SHAFT COMP.	1
8-8	157-3.10.610	TRANSMISSION DRUM COMP.	1
8-9	157-3.11.836	WASHER (ST) 15×19×1	1
8-10	169-4.10.420	SHIFTING SHAFT COMP.	1
8-11	157-3.10.820	DECLUTCH SHIFT SHAFT	1
8-12	157-3.10.821	DECLUTCH SHIFT	1
8-13	157-3.03.612	SHORT SHAFT	2
8-14	169-4.10.450	OUTPUT GEAR SHAFT	1
8-15	GB/T5801 RNA4905	NEEDLE BEARING RNA4905	1
8-16	157-3.12.415	OIL SEAL 30×40×6	1
8-17	157-3.12.105	REAR ABSORBER BUSHING	2
8-18	GB/T276 6205	BALL BEARING 6205—2RS	1
8-19	GB/T893.1 52	SNAP RING 52	1
8-20	157-3.11.849	WASHER 25×34×1	1
8-21	GB/T894.1 25	SNAP RING 25	1
8-22	152.11.822	DRAIN PLUG M12×1.5	1
8-23	152.11.306	WASHER 12×20×1.5	1
8-24	157-3.12.404	OIL SEAL 14×28×7	1

FIG. 9
JINGLANG TYPE-RUYI LEFT COVER COMP.
(169.03.400B)

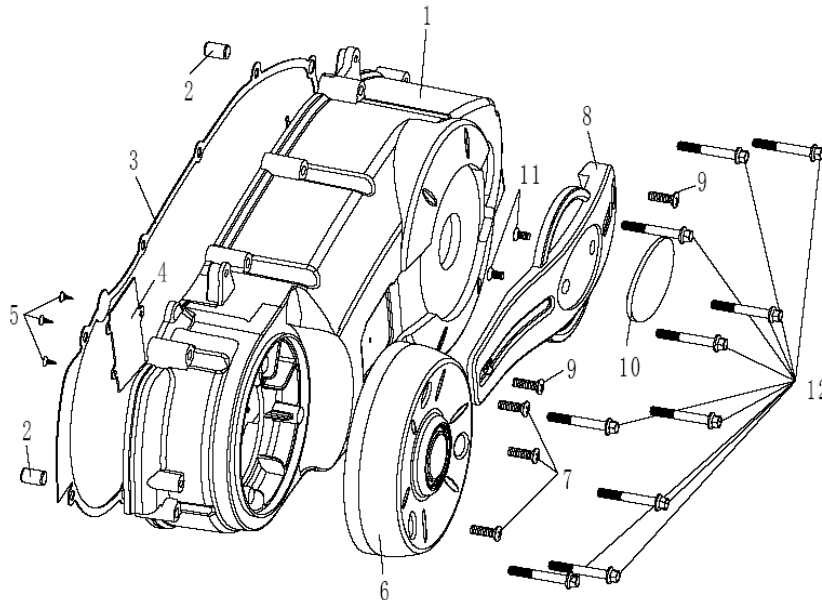

JINGLANG TYPE-RUYI LEFT COVER COMP. (169.03.400B)			
REF NO.	PART NO.	DESCRIPTION	QTY
9-1	169.03.311B	LEFT CRANKCASE COVER (RUYI STYLE)	1
9-2	157-3.11.508	PIN Ø10x14	2
9-3	169.12.302	LEFT CRANKCASE COVER SPACER	1
9-4	169.11.119B	L. CRANK CASE COVER PLATE	2
9-5	GB/T 845	TAPPING SCREW ST3.5x8	3
9-6	169.03.315	FRONT COVER COMP.	1
9-7	GB/T818	SCREW M6x20	3
9-8	152.03.320	REAR COVER	1
9-9	GB/T 818	SCREW M5x16	2
9-10	152.03.312	NAME PLATE COVER	1
9-11	GB/T 818	SCREW M5x10	2
9-12	GB/T16674.1	FLANGE BOLT M6x40	10

FIG. 10

INTAKE PIPE, CARBURETOR

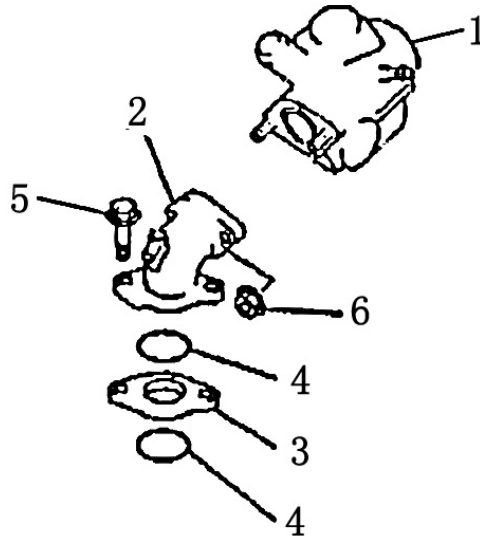

INTAKE PIPE, CARBURETOR			
REF NO.	PART NO.	DESCRIPTION	QTY
10-1	169.08.100	CARBURETOR COMP.	1
10-2	169.08.210	INTAKE PIPE COMP.	1
10-3	169.08.260	INTAKE PIPE INSULATION SPACER	1
10-4	169.12.523	O-RING 35X2	2
10-5	GB/T 16674.1 M6X25	BOLT M6X25	2
10-6	GB/T6177.1 M6	NUT M6	2

FIG. 11
ELECTRIC PARTS

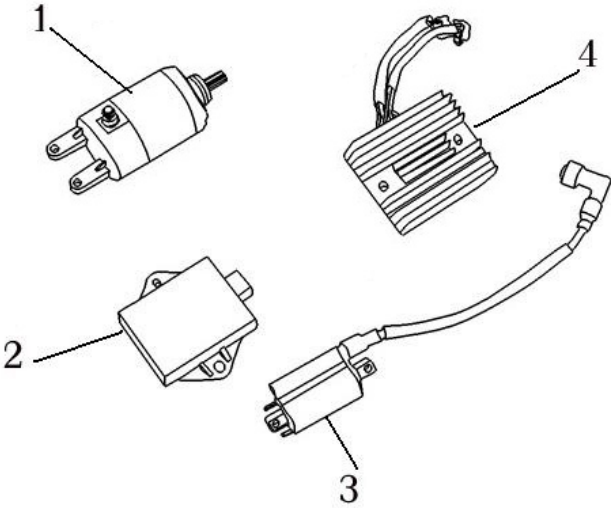

ELECTRIC PARTS			
REF NO.	PART NO.	DESCRIPTION	QTY
11-1	169.06.110	STARTOR COMP.	1
11-2	169.07.410	IGNITOR	1
11-3	169.07.310	IGNITION COIL	1
11-4	169.07.510	RECTIFIER COMP. REGULATE	1

FIG. 13
FRAME GROUP

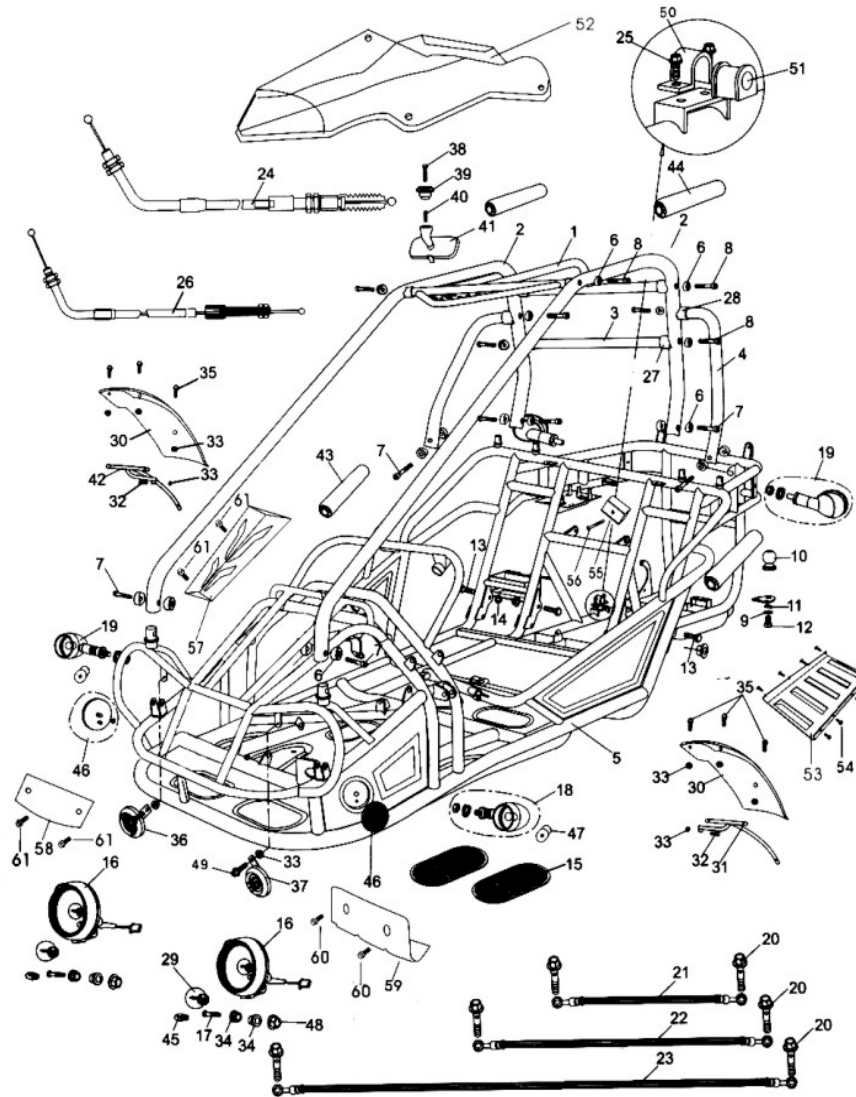

FRAME GROUP			
REF NO.	PART NO.	DESCRIPTION	QTY
13-1	6.000.061	C.B.C.CROSS BAR,(B.R.S.)	1
13-2	8.070.034-250	C.B.C.BAR CAGE(B.R.S.)	2
13-3	8.080.033	C.B.C.CROSS BAR,RR(B.R.S.)	1
13-4	8.070.035	C.B.C.BAR,L./R.SIDE(B.R.S.)	2
13-5	2.010.045	FRAME COMP.(B.R.S.)	1
13-6	7.010.049	R-WASHER	18
13-7	9.908.050N	SOCKET BOLT M8*1.25*50	6
13-8	9.908.055N	SOCKET BOLT M8*1.25*55	10

13-9	9.300.016	WASHER ϕ 16	1
13-10	2.200.001	TOW BALL	1
13-11	9.400.016	LOCK WASHER ϕ 16	1
13-12	9.101.625	BOLT M16*25	1
13-13	9.112.025	BOLT-WASHER M12*1.25*25	4
13-14	9.220.012	LOCKING FLANGE NUT M12	4
13-15	7.020.012	RUBER FOOT FLATE	2
13-16	6.000.104	HEADLIGHT UNIT	2
13-17	9.108.050	BOLT-WASHER M8*1.25*50	2
13-18	6.000.155	WINKER LIGHT ASSY.L.FR./R.RR.	2
13-19	6.000.156	WINKER LIGHT ASSY.R.FR./L.RR.	2
13-20	9.700.004	BANJO BOLT M10*24	6
13-21	6.000.089	BRAKE HOSE ASSY.L. 34"	1
13-22	6.000.090	BRAKE HOSE ASSY.R. 43"	1
13-23	6.000.230	BRAKE HOSE ASSY.RR. 80"	1
13-24	6.000.232-300G	THROTTLE CABLE COMP.	1
13-25	9.106.012	BOLT M6*12	6
13-26	6.000.231-300G	PARKING BRAKE CABLE COMP.	1
13-27	7.010.017	TUBE SEAT ϕ 35	6
13-28	7.010.016	TUBE SEAT ϕ 32	2
13-29	9.090.003	HEADLIGHT BULB 35W/35W/12V	2
13-30	7.110.034	FENDER,FR.	2
13-31	6.100.067	FRONT FENDER BRACKET,L.	1
13-32	9.100.640	BOLT M6*40	2
13-33	9.210.008	LOCKING FLANGE NUT M8	10
13-34	7.020.049	HEADLIGHT RUBBER MOUNT	4
13-35	9.106.014	BOLT-WASHER M6*14	6
13-36	6.000.135	HORN,H.	1
13-37	6.000.136	HORN,L.	1
13-38	9.100.525	BOLT M5*25	1
13-39	8.010.086	REAR MIRROR MOUNT	1
13-40	8.040.005	REAR VIEW MIRROR SPRING	1
13-41	6.000.084	REAR MIRROR ASSY.	1
13-42	6.100.102	FRONT FENDER BRACKET,R.	1
13-43	6.000.083	FOAM PADDING-1	2
13-44	6.000.116	FOAM PADDING-2	2
13-45	9.000.004-A	POSITION LIGHT BULB 3W 12V	2
13-46	6.000.144	FRONT REFLECTOR	2
13-47	9.090.006	WINKER BULB 10W 12V	4
13-48	9.220.008	LOCKING FLANGE NUT M8	2
13-49	9.106.012	BOLT M6*12	2
13-50	2.100.002	SWAY BAR BRACE	3
13-51	2.100.001	SWAY BAR BRACE BUSHING	3
13-52	6.100.061	AWNING	1

13-53	7.110.030	WIND GUIDE	1
13-54	9.100.612	SCREW M6*12	8
13-55	7.120.010	RUBBER PIECE	1
13-56	9.100.640	BOLT M6*40	1
13-57	9.131.192	DECORATION PLATE I	1
13-58	9.130.192	DECORATION PLATE II	1
13-59	9.312.192	PROTECTING PLATE	1
13-60	2.041.076	BOLT M8*10	2
13-61	5.120.074	BOLT M6*20	4

FIG. 14
STEERING SHAFT ASSY.

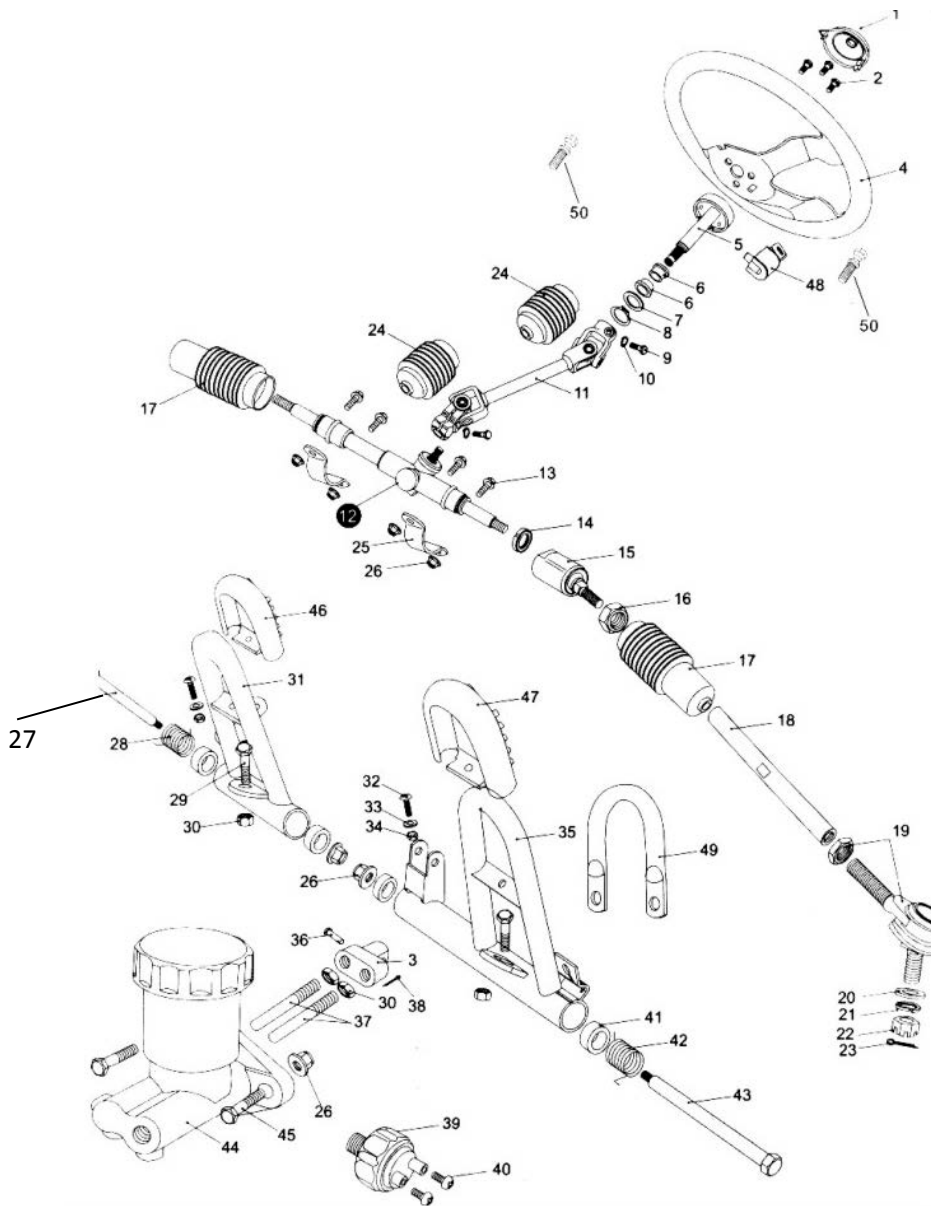

STEERING SHAFT ASSY.			
REF NO.	PART NO.	DESCRIPTION	QTY
14-1	7.010.041	STEERING BOLT COVER	1
14-2	9.100.612	SCREW M6*12	3
14-3	8.030.024	SPINDLE WHEEL	1
14-4	7.020.038	STEERING WHEEL	1
14-5	6.000.122	STEERING SHAFT	1
14-6	6.017.001	NEEDLE NK2016	2
14-7	9.700.020	SPECIAL WAHER ϕ 20	1
14-8	9.700.120	CIRCLIP ϕ 20	1

14-9	9.100.825	BOLT M8*25	2
14-10	9.400.008	LOCK WASHER ϕ 8	2
14-11	6.000.093-250	STEERING KNUCKLE	1
14-12	4.000.014	STEERING GEAR	1
14-13	9.108.025	BOLT-WASHER M8*1.25*25	4
14-14	9.900.016	ROUND NUT M16*1.5	2
14-15	4.000.008-250	STEERING GEAR45 DEGREE ANGLE	2
14-16	9.200.010	NUT M10	2
14-17	7.020.002	BALL JIONT DUST COVER	2
14-18	8.010.157	TIE ROD	2
14-19	6.000.062	ROD END	2
14-20	9.300.010	FLAT WASHER ϕ 10	2
14-21	9.400.010	LOCK WSAHER ϕ 10	2
14-22	9.800.010	CASTLE NUT ϕ 10	2
14-23	9.500.215	COTTER PIN ϕ 2*15	2
14-24	7.020.066	STEERING KNUCKLE DUST COVER	2
14-25	8.020.014	STEERING GEAR BRACKET	2
14-26	9.220.008	LOCKING FLANGE NUT M8	8
14-27	9.708.145	THRORRLE PEDAL BOLT M8*1.25*145	1
14-28	8.040.001	THROTTLE PEDAL RETURN SPING,L.	1
14-29	9.108.040	BOLT-WASHER M8*1.25*40	2
14-30	9.200.008	NUT M8	2
14-31	4.000.016	THROTTLE PEDAL COMP.	1
14-32	9.600.515	PAN SCREW M5*15	2
14-33	9.300.005	FLAT WASHER ϕ 5	2
14-34	9.210.005	NYLON LOCK NUT M5	2
14-35	4.000.015	BRAKE PEDAL COMP.	1
14-36	9.700.624	PIN ϕ 6*24	1
14-37	8.010.081	SPINDLE PIN	2
14-38	9.500.212	COTTER PIN ϕ 2*12	1
14-39	6.000.063	BRAKE LAMP SWITCH ASSY.	1
14-40	9.600.306	PAN SCREW M3*6	2
14-41	7.010.004	PEDAL BUSH	4
14-42	8.040.007	BRAKE PEDAL RETURN SPRING ,R.	1
14-43	9.708.222	BRAKE PEDAL BOLT M8*1.25*222	1
14-44	6.000.076	MASTER CYLINDER	1
14-45	9.108.035	BOLT-WASHER M8*1.25*35	2
14-46	7.020.036	THROTTLE PEDAL PAD	1
14-47	7.020.037	BRAKE PEDAL PAD	1
14-48	6.000.134	STEERING WHEEL LOCK	1
14-49	8.070.044	MASTER CYLINDER BRACKET	1
14-50	8.016.043	BOLT M6*19	2

FIG. 15
FRONT SUSPENSION ASSY.

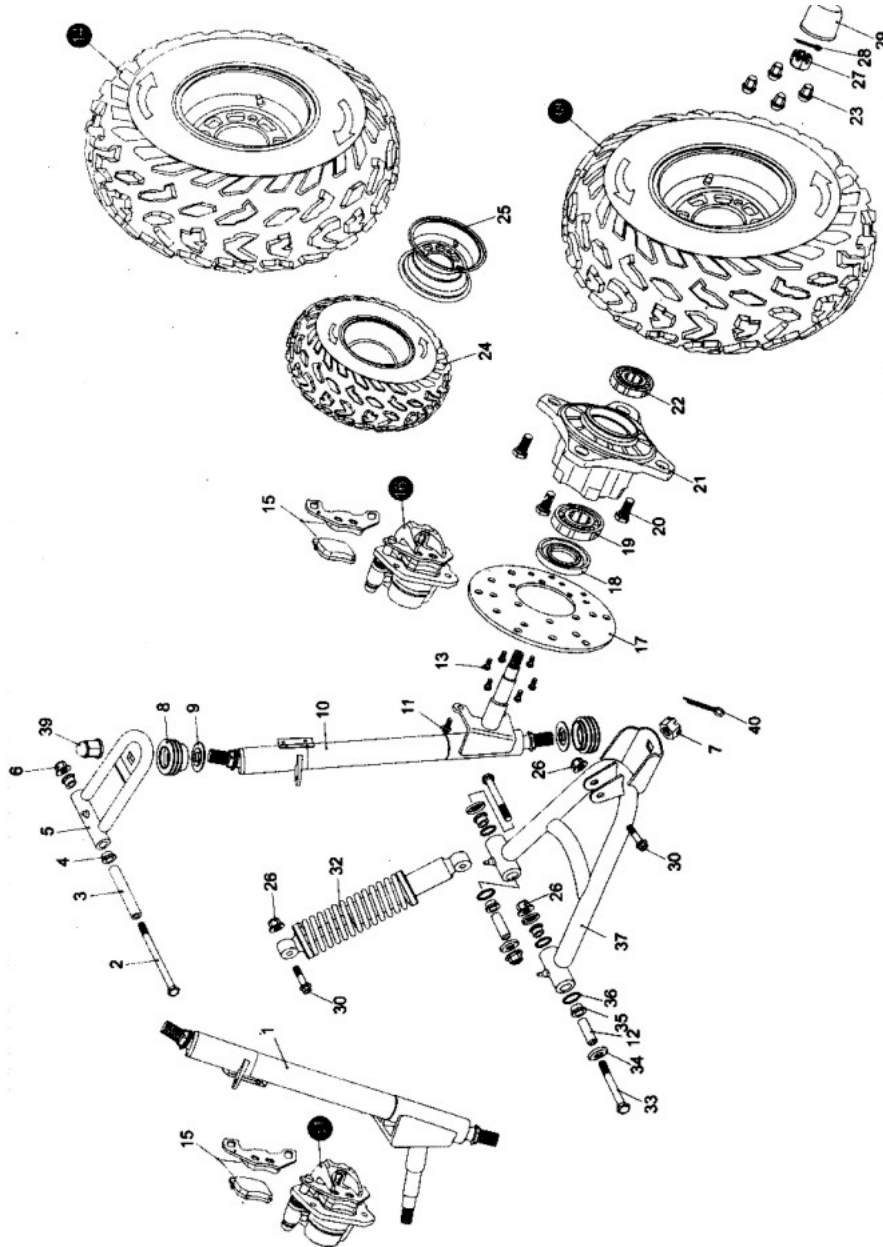

FRONT SUSPENSION ASSY.			
REF NO.	PART NO.	DESCRIPTION	QTY
15-1	2.000.028-SS	STRUT AND SPINDLE SUPPORT,R.WITH BRACKET-BLACK	1
15-2	9.108.105	BOLT-WASHER M8*1.25*105	2
15-3	8.010.015	UPPER SUSPENSION ARM COLLAR	2
15-4	7.010.003	UPPER SUSPENSION ARM BUSH	4

15-5	4.000.004	UPPER SUSPENSION ARM	2
15-6	9.220.008	LOCKING FLANGE NUT M8	2
15-7	9.800.012	CASTLE NUT M12	2
15-8	7.020.025	BALL HEAD DUST SEAL	4
15-9	8.020.053	BALL HEAD SPACER	4
15-10	2.000.027-SS	STRUT AND SPINDLE SUPPORT,L.WITH BRACKET-BLACK	1
15-11	9.908.104	BOLT M8*14	4
15-12	8.010.014	LOWER SUSPENSION ARM COLLAR	4
15-13	9.906.012	BOLT STRAP M6*12	12
15-14	6.000.141	FR.WHEEL ASSY.,R. 20*7-8	1
15-15	7.020.016	FR.BRAKE CALIPER PAD SET	2
15-16	6.000.028	FRONT BRAKE CALIPER,L.	1
15-17	8.010.054	BRAKE DISC.	2
15-18	9.040.002	DUST SEAL 47*25-7	2
15-19	9.030.002-Z	BEARING 6204-Z	2
15-20	9.710.031	CAP LUG NUT M10*1.25*31	8
15-21	8.010.085	WHEEL HUB	2
15-22	9.030.010-Z	BEARIG 6202-Z	2
15-23	8.010.118	CAP LUG NUT M10	8
15-24	7.020.050	TIRE,FR.20*7-8	2
15-25	6.000.142B	RIM,FR.	2
15-26	9.220.010	LOCKING FLANGE NUT M10	8
15-27	9.800.014	CASTLE NUT M14	2
15-28	9.500.220	COTTER PIN ϕ 2*20	2
15-29	7.020.039	HUB COVER	2
15-30	9.110.040	BOLT-WASHER M10*1.25*40	4
15-31	6.000.095	FRONT BRAKE CALIPER,R.	1
15-32	6.000.325	CUSHION ASSY.,FR.L=325	2
15-33	9.110.080	BOLT-WASHER M10*1.25*80	4
15-34	8.020.034	LOWER SUSPENSION ARM DUSH CAP	8
15-35	7.010.002	LOWER SUSPENSION ARM BUSH	8
15-36	9.040.001	O-RING ϕ 21.2*2.65	8
15-37	4.000.023	LOWER SUSPENSION ARM ASSY.	2
15-38	6.000.140B	FR.WHEEL ASSY.,L. 20*7-8	1
15-39	8.010.140	ACORN M12	2
15-40	9.500.200	COTTER PIN ϕ 3.2*26	2

FIG. 16

FULL SHIFTING ASSY.

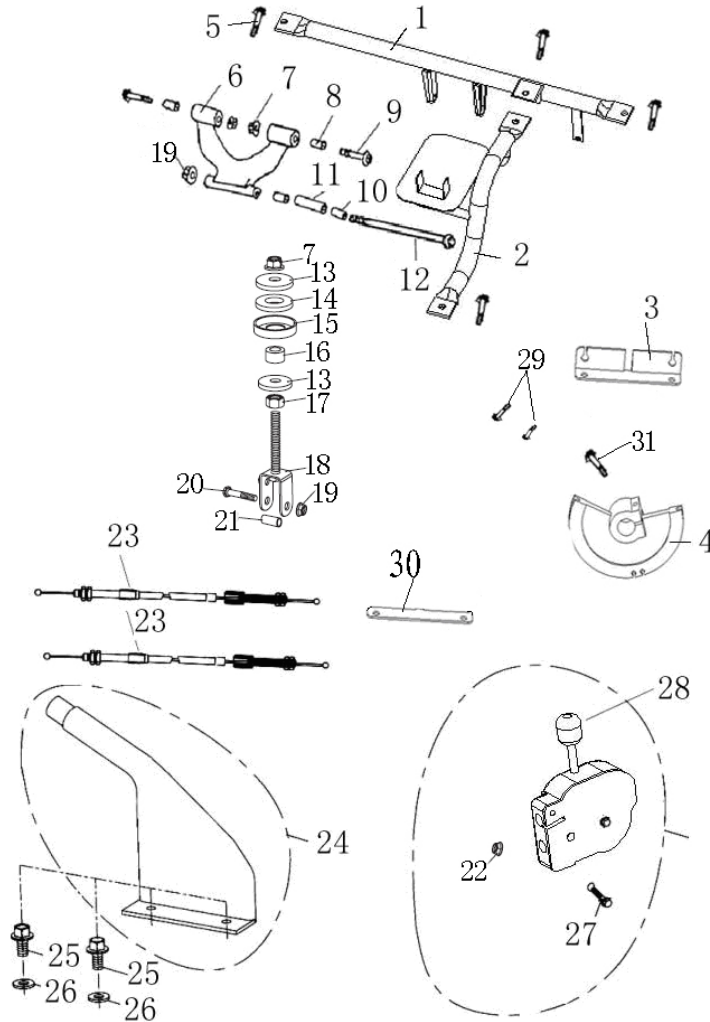

FULL SHIFTING ASSY.			
REF NO.	PART NO.	DESCRIPTION	QT Y
16-1	58330-300GK	ENGINE MOUNT BRACKET I	1
16-2	58340-300GK	ENGINE MOUNT BRACKET II	1
16-3	40001-300GK	REVERSE CABLE FIXED PLATE	1
16-4	40002-300GK	SHIFTER DISK	1
16-5	578910020125	BOLT M10x1.25x20	4
16-6	58310300k000	FRONT ENGINE MOUNT BRACKET	1
16-7	618712000125	NUT M12x1.25	3
16-8	58320300k000	BUSHING ENGINE BRACKET 1	2
16-9	578712060125	ENGINE BRACKET BOLT	2
16-10	58330300k000	BUSHING ENGINE BRACKET 2	2
16-11	58002300k000	SPACER ENGINE BRACKET	1

16-12	578710225125	ENGINE MOUNTING BOLT M10x1.25x225	1
16-13	8.010.042	WASHER-CHAIN ADJUSTER (φ12xφ35x6)	2
16-14	7.020.001	CAP WASHER-CHAIN ADJUSTER	1
16-15	8.010.045	BOTTOM CAP WASHER-CHAIN ADJUSTER	1
16-16	8.010.041	BUSHING CHAIN ADJUSTER	1
16-17	617012000125	BOLT M12x1.25	1
16-18	6.000.026-CAA	CHAIN ADJUSTER ASSY.	1
16-19	618710000125	LOCKING FLANGE NUT M10x1.25	2
16-20	578510045125	BOLT M10x1.25	1
16-21	8.010.076	COLLAR ENGINE MOUNT BOLT PLATE	1
16-22	618708000125	LOCKING FLANGE NUT M 8x1.25	2
16-23	40010-300GK	REVERSE CABLE	2
16-24	6.000.233-250	PARKING BRAKE ASSY.	1
16-25	9.108.020	BOLT-WASHER M8X20X1.25	2
16-26	9.300.008	WASHER 8	2
16-27	578908020125	BOLT M8	1
16-28	40700-300GK	SHIFTER HOISE ASSY.	1
16-29	578906012100	NUT M6X12	2
16-30	58001-300GK	ENGINE FIXED PLATE. RR	1

FIG. 17

REAR CARGO RACK / SEAT / BELT

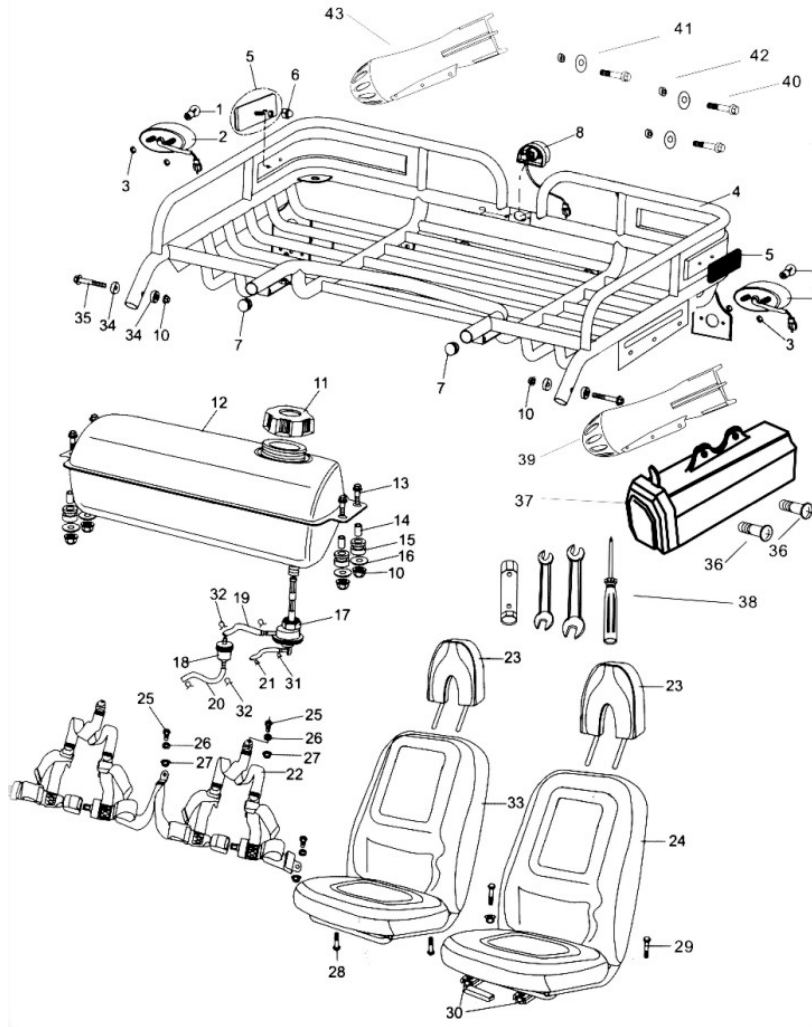

REAR CARGO RACK / SEAT / BELT			
REF NO.	PART NO.	DESCRIPTION	QTY
17-1	9.090.005	TAIL LIGHT BULB 21W/5W 12V	2
17-2	6.000.144	TAIL LIGHT	2
17-3	9.210.006	LOCK NYLON NUT M6	4
17-4	2.100.046-250	REAR CARGO RACK (B.R.S.)	1
17-5	6.000.111	REAR SIDE REFLECTOR	4
17-6	8.010.171	LUG NUT	2
17-7	7.020.032	TUBE COVER	2
17-8	6.000.241	LICENSE LIGHT ASSY.	2
17-9	9.804.003	SCREW ST3.5*10	4
17-10	9.220.008	LOCKING FLANGE NUT M8	6
17-11	6.000.145	FUEL TANK CAP COMP.	1

17-12	4.000.029	FUEL TANK COMP.(B.R.S.)	1
17-13	9.108.025	BOLT-WASHER M8*1.25*25	4
17-14	8.010.034	TANK COMP. COLLAR	4
17-15	7.020.005	RUBBER MOUNT	4
17-16	9.300.008	FLAT WASHER ϕ 8	4
17-17	6.000.046-250	FUEL AUTO COCK ASSY.NO/OFF VALVE	1
17-18	6.000.056	GAS FILTER	1
17-19	7.020.030	TUBE COMP.FUEL #1	1
17-20	7.020.029	TUBE COMP.FUEL #2	1
17-21	7.020.031	TUBE COMP.VACUUM	1
17-22	6.000.146	SAFETY BELT	1
17-23	6.000.262	HEAD-REST	2
17-24	6.000.264	SEAT COMP.L.	1
17-25	9.700.001	SPECIAL BOLT M7/16"*28	1
17-26	9.700.002	BELT WASHER ϕ 12	1
17-27	9.700.003	NUT BELT M7/A6"	1
17-28	9.900.840	BOLT STRAP M8*1.25*40	2
17-29	9.910.841	BOLT M8*1.25*45	2
17-30	6.000.057	SEAT RAIL SET	1
17-31	8.040.008	VACUUM TUBE	2
17-32	8.040.009	FUEL TUBE	4
17-33	6.000.263	SEAT COMP.R.	1
17-34	8.010.047	R-WASHER	4
17-35	9.908.055	BOLT M8*1.25*55	2
17-36	9.100.612	SCREW 6*12	2
17-37	7.110.002	TOOL KIT	1
17-38	7.110.003	TOOLS	1
17-39	4.000.037	AUXILIARY SPERKER	1
17-40	9.032.074	BOLT M6*20	6
17-41	9.300.005	FLAT WASHER ϕ 5	6
17-42	9.200.006	NUT M6	6
17-43	4.000.036	MAIN SPEAKER	1

FIG. 18

AIR CLEANER/RADIATOR/BATTERY/MUFFLER ASSY.

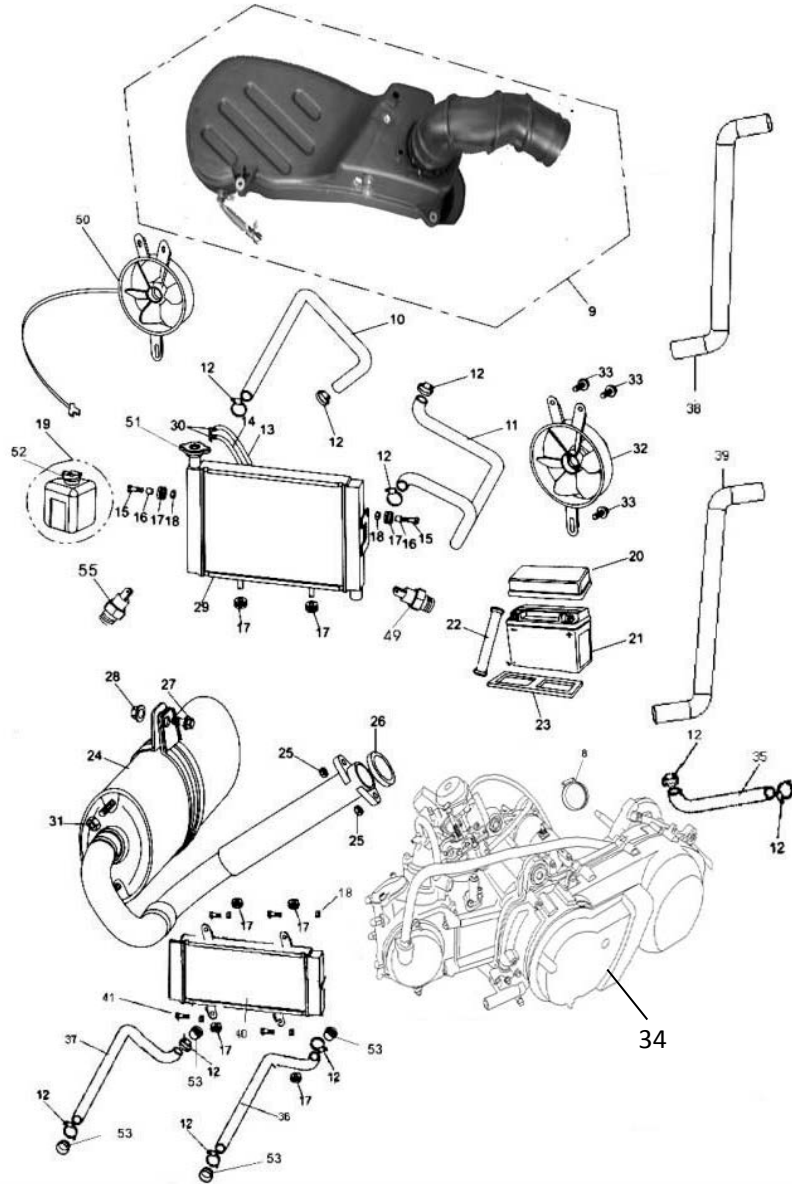

AIR CLEANER/RADIATOR/BATTERY/MUFFLER ASSY.			
REF NO.	PART NO.	DESCRIPTION	QTY
18-9	49000-300G	AIR CLEANER ASSY.	1
18-10	7.090.042	TUBE COMP.WATER 1#	1
18-11	7.190.043	TUBE COMP.WATER 2#	1
18-12	7.090.044	TUBE CLAMP	10
18-13	7.090.045	TUBE COMP.WATER 3#	1
18-14	7.090.046	TUBE COMP.WATER 4#	1

18-15	9.100.830	BOLT M8*30*1.25	2
18-16	7.090.047	RADIATOR COMP.COLLAR	2
18-17	7.020.069	RUBBER MOUNT	6
18-18	9.200.008	NUT M8	6
18-19	6.000.248	COLLANT TANK	1
18-20	7.010.028	BATTERY COVER	1
18-21	6.000.085	BATTERY (YTX12-BS)	1
18-22	7.021.023	BATTERY BAND	1
18-23	7.020.020	BATTERY LOWER	1
18-24	57100-300G	MUFFLER COMP.EX.	1
18-25	9.040.027	MUFFLER JOINT NUT M6	2
18-26	7.090.050	EX.PIPE GASKET	1
18-27	9.110.030	BOLT-WASHER M10*1.25*30	1
18-28	9.020.010	NUT M10	1
18-29	14210-300G	RADIATOR COMP.	1
18-30	7.090.051	TUBE CLAMP	2
18-31	9.200.006	NUT M6	2
18-32	6.100.249-300G	FAN COMP.	2
18-33	7.090.052	BOLT M6*10	6
18-34	10000-300G	300cc ENGINE	1
18-35	7.090.053	TUBE COMP WATER 5#	1
18-36	7.090.054	TUBE COMP WATER 6#	1
18-37	7.090.055	TUBE COMP WATER 7#	1
18-38	7.090.056	TUBE COMP WATER 1#	1
18-39	7.090.057	TUBE COMP WATER 2#	1
18-40	4.000.034	RADIATOR.COMP	1
18-41	9.100.625	BOLT M6*25	4
18-42	6.100.162-300G	BOOT.SIDE CASE	2
18-43	8.120.055-300G	CLAMP.BOOT	2
18-49	7.190.009	HEAT SENSITIVE SWICH	1
18-50	6.100.249N	FAN COMP2	1
18-51	4.000.033N	RADIATOR COMP COVER	1
18-52	6.000.248N	COLLANT TANK CAP	1
18-53	7.090.058	RUBBER STOPPER	4
(18-54)	8.020.166-250	250CC MUFFLER CLAMP	1
18-55	9.010.098	WATER TEMPERATURE INDUCTOR	1

FIG. 19
REAR SUSPENSION ASSY.

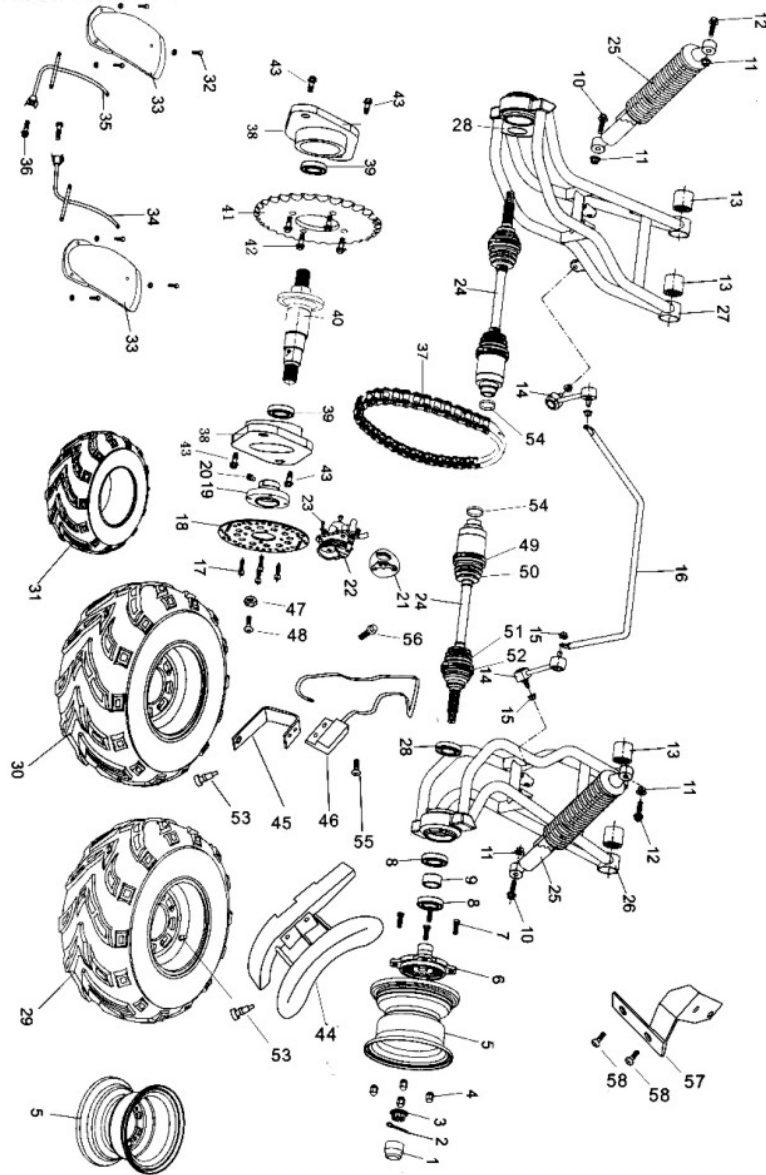

REAR SUSPENSION ASSY.			
REF NO.	PART NO.	DESCRIPTION	QTY
19-1	7.020.039	RR.HUB COVER	2
19-2	9.500.430	COTTER PIN ϕ 4*30	2
19-3	9.800.018	CASTLE NUT M18	2
19-4	8.010.118	LUG NUT CAP M10	8
19-5	6.000.143B	RIM RR.	2
19-6	8.010.169	REAR WHEEL HUB	2

19-7	9.710.031	TIRE BOLT M10*1.25*31	8
19-8	9.030.007	BEARING 6007	4
19-9	8.010.170	COLLAR	2
19-10	9.112.055	BOLT-WASHER M12*1.25*55	2
19-11	9.220.012	LOCKING FLANGE NUT M12	4
19-12	9.112.050	BOLT-WASHER M12*1.25*50	2
19-13	7.020.008	SWING ARM CUSHION BUSH	4
19-14	6.000.242	BALANCE LEVER LINK ROD	2
19-15	9.220.010	LOCKING FLANGE NUT M10*1.25	2
19-16	6.000.243	BALANCE LEVER	1
19-17	9.108.020	BOLT-WASHER M8*20*1.25	4
19-18	8.010.053-SS	RR.BRAKE DISC.	1
19-19	8.030.036	BRAKE DISC.W/SPEEDO MAGNET HOLE	1
19-20	9.101.018	BOLT M10*1.5*18	1
19-21	7.020.022-250	RR.BRAKE PAD SET	1
19-22	6.000.229-250-300G	CALIPER HYDRAULICAL BRAKE, RR.	1
19-23	9.908.014	ALLEN HEAD BOLE M8*1.25*16	2
19-24	6.000.244-C	CV/SHAFT JOINT	2
19-25	6.000.245	CUSHION ASSY., RR. L=480	2
19-26	6.000.247	SWING ARM COMP. R.	1
19-27	6.000.246	SWING ARM COMP.L.	1
19-28	9.040.011	DUST SEAL ϕ 62*44*10	2
19-29	6.000.148B	REAR WHEEL ASSY.,R.	1
19-30	6.000.147B	REAR WHEEL ASSY.,L.	1
19-31	7.020.052	TIRE ,RR.22*10-10	1
19-32	9.906.016	BOLT-WASHER M6*16	6
19-33	7.010.064	FENDER, RR.	2
19-34	6.100.068	REAR FENDER BRACKET ,R.	1
19-35	6.100.101	REAR FENDER BRACKET ,L.	1
19-36	9.105.045	BOLT-WASHER M8*1.25*45	2
19-37	9.170.002	CHAIN O-RING DRIVE	1
19-38	8.130.033	HOUSING COMP.PP AXLE BRG	2
19-39	9.030.011	BEARING E6007	2
19-40	8.110.057-300G	AXLE	1
19-41	8.110.077	REAR SPROCKET	1
19-42	9.112.030	BOLT-WASHER	4
19-43	9.112.027	BOLT-WASHER	4
19-44	7.190.010	PROTECTOR,DISK	1
19-45	7.190.011	BRACKET	1
19-46	7.190.012	SENSOR	1
19-47	7.190.013	AWICO	1
19-48	9.103.005	SCREW M3*5	1
19-49	7.190.014	CIRCLIP1	1
19-50	7.190.015	RUBBER BUSH1	1

19-51	7.190.016	RUBBER BUSH2	1
19-52	7.190.017	CIRCLIP2	1
19-53	7.190.018	TIRE NIPPLE	2
19-54	7.190.019	REAR AXLE CIRCLIP	2
19-55	7.120.081	SCREN M3*6	2
19-56	7.145.076	BOLT M6*16	2
19-57	8.020.410	BRACKET	1
19-58	9.220.006	LOCKING FLANGE NUT M6	2

FIG. 20

WIRE HARNESS / ELECTRIC PARTS

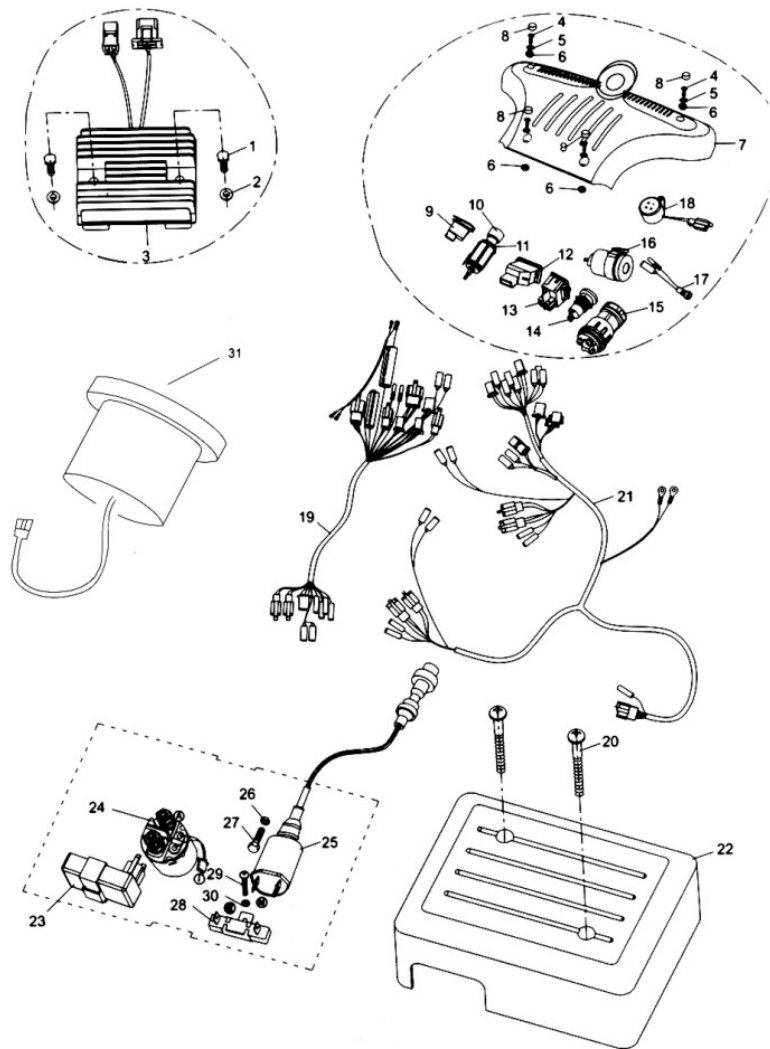

WIRE HARNESS / ELECTRIC PARTS			
REF NO.	PART NO.	DESCRIPTION	QTY
20-1	9.100.630	BOLT M6*30	2
20-2	9.200.006	NUT M6	2
20-3	6.000.250	REGULATE RECTIFIER COMP.	1
20-4	9.600.615	PAN SCREW M6*15	4
20-5	9.300.006	WASHER ϕ 6	4
20-6	9.210.005	LOCKING NYLON NUT M5	2
20-7	7.110.038	SWITCH PANEL COVER	1
20-8	7.010.061	BOLT COVER	4
20-9	6.000.079	HORN SWITCH	1

20-10	7.020.051	POWER OUTLET COVER	1
20-11	6.000.087	POWER OUTLET	1
20-12	6.000.113	WINKER SWITCH UNIT	1
20-13	6.000.160	DIMMER SWITCH UNIT	1
20-14	6.000.159	ENGINE STOP BUTTON	1
20-15	6.000.158	IGNITION START SWITCH	1
20-16	6.000.153	RELAY COMP.AUDIBLE PILOT&WINKER	1
20-17	6.000.251	TEMPERATURE BUZZER	1
20-18	6.000.252	HORN RECTIFIER	1
20-19	6.100.253	SOCKET COMP.	1
20-20	9.600.655	PAN SCREW M6*55	2
20-21	6.100.254	WIRE HARNESS	2
20-22	7.010.029	ELECTRIC ASSY.COVER	1
20-23	80018-300K	C.D.I.UNIT COMP.	1
20-24	6.000.256	STARTING RELAY	1
20-25	80016-300K	IGNITION COIL COMP.	1
20-26	9.210.006	LOCK NYLON NUT M6	1
20-27	9.600.525	PAN SCREW M5*25	1
20-28	6.000.038	RESISTOR COMP.10W 10	1
20-29	9.600.410	PAN SCREW M4*10	1
20-30	9.210.004	LOCK NYLON NUT M4	1
20-31	4.000.038-250	SPEEDOMETER WITH HI/LO	1

FIG. 21

WARNING STICKERS

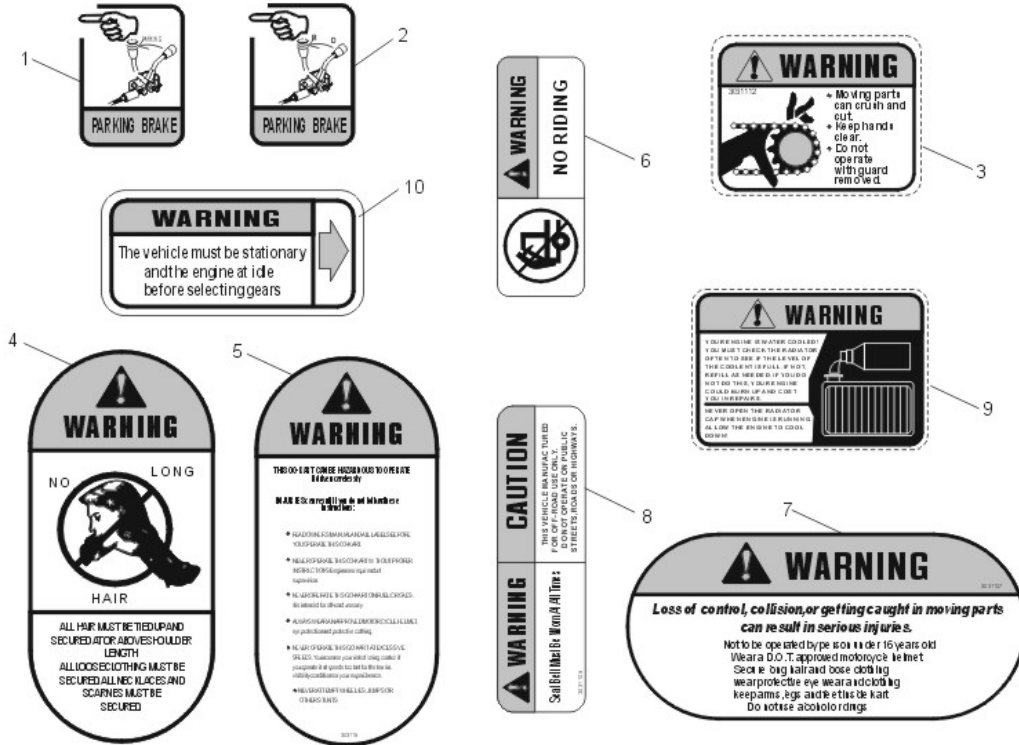

WARNING STICKERS			
REF NO.	PART NO.	DESCRIPTION	QTY
21-1	9.090.007	LABEL. PARKING BRAKE	1
21-2	9.090.008	LABEL.REVERSE LEVER	1
21-3	9.090.023	LABEL.GEAR CASE	1
21-4	9.090.010	LABEL.NO LONG HAIR	1
21-5	9.090.011	LABEL.WARNING	1
21-6	9.090.012	LABEL.NO CLIMBING	1
21-7	9.090.013	LABEL.WARNING	1
21-8	9.090.014	LABEL.SEAT BELT	1
21-9	9.090.024	LABEL.RADIATOR	1
21-10	9.090.017	LABEL.WARNING	1