



SLIDER

SE20 INSTRUCTION MANUAL

## Quick Start Guide

### STEP ONE: Remove the Mounting Plate

- 1 To get started open the safe using one of your backup keys via the keyhole at the back of the safe (see FIGURE A). Open the cover, push key in and rotate key clockwise to open the safe.
- 2 Locate the release clip on the same side as the attached mounting plate.
- 3 Use your thumb or finger to pull the release clip back, and lift the safe off the mount at the same time (see FIGURE B/C). The safe will not remove without pulling the release clip back.



FIGURE A

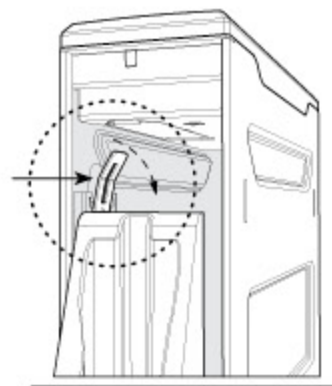

FIGURE B

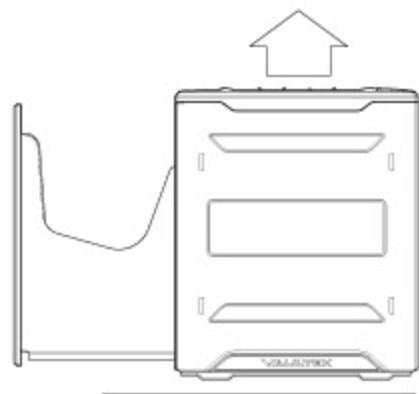

FIGURE C

TUTORIALS ONLINE AT [VAULTEKSAFE.COM/SLIDERSERIES-SUPPORT](http://VAULTEKSAFE.COM/SLIDERSERIES-SUPPORT)

### STEP TWO: Battery Installation

- 1 To get started open the safe using one of your backup keys via the keyhole at the back of the safe. Open keyhole cover, push key in and rotate key clockwise to open the safe.
- 2 Locate the battery door and open by depressing the tab near the front of the cover, allowing the door to fold down (FIGURE D/E).
- 3 Snap the battery (included in accessory box) into the battery door (FIGURE E/F). The battery door has molded snaps for the battery to clip into. Note that your Vaultek® safe automatically detects the polarity of the battery and can be snapped in either direction.

**TIP!** Make sure to push battery to back of the battery door allowing the door to close properly.

- 4 Close the battery door. When the battery door is closed you will hear a short welcome tone and the keypad will light up.

**IMPORTANT:** First time users should change the default code immediately after installing the battery to prevent unauthorized access to your safe.



FIGURE D



FIGURE E



FIGURE F

## STEP THREE: Master Code Programming



First time users should change the default code as soon as possible to prevent unauthorized access to your safe.

### TIP: Code Requirements

- Your code can be a minimum of 4 and a maximum of 8 digits. We recommend a code 6 to 8 digits in length using at least one of each key to make it more difficult for someone to guess your code. For your security, the safe will time out and sleep for 4 minutes if 6 incorrect entries are made.
- Two keys cannot be pressed simultaneously.
- Programming a new code will overwrite your previous code.

- 1 Open the safe. (The default master code is 1-2-3-4-5 on the keypad)
- 2 With the safe open, press and hold the "PROGRAM" button (3 seconds)(FIGURE G) until all keys turn RED and let go.
- 3 Enter your NEW master code.
- 4 **IMMEDIATELY** Press and hold the "PROGRAM" button a second time (3 seconds) until all keys turn RED and let go.
- 5 Enter your NEW master code a second time.
- 6 **IMMEDIATELY** Press and hold the "PROGRAM" button together a third time (3 seconds) until the safe beeps and all keys turn GREEN and let go. This tone confirms that the code has been reset.

If you make a mistake and the new code will not work, simply start over with step 2.

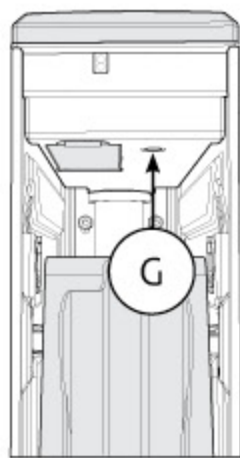

FIGURE G

## STEP FOUR: Product Registration



Vaultek® strongly encourages you to register your safe as soon as you receive it.

**Registration provides many benefits including three year warranty, technical support, and ordering replacement keys should you misplace them.** Your Vaultek® safe has a unique product number on the inside of the battery door and a 4-digit ID number engraved on the keys. You will need these numbers to register your safe.

- 1 Locate your product number. It is printed on the first page of this user manual and on the inside of the battery door (FIGURE H/I).
- 2 Find your 4-digit ID number engraved on the keys (FIGURE J).
- 3 Please visit the Vaultek® website at [vaulteksafe.com](http://vaulteksafe.com) and click Support/Product Registration.
- 4 Enter the required information in the form and click submit.



FIGURE H

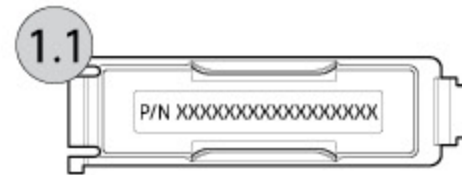

FIGURE I



FIGURE J

## Table of Contents

<b>Product Overview</b> .....	<b>01 / 02</b>
<b>Introduction / Warnings</b> .....	<b>03 / 04</b>
<b>Battery Operation / Battery Maintenance</b> .....	<b>05 / 07</b>
Battery Installation .....	05
Charging the Battery .....	06
<b>Master Code Programming</b> .....	<b>08</b>
<b>Hot Keys</b> .....	<b>09 / 10</b>
Tamper Detection .....	09
Toggle Stealth Mode .....	09
Toggle Travel Mode .....	09
View Battery Status .....	09
Interior Light Time Extension .....	09
Toggle Alert of Unlock .....	09
Toggle Interior Light .....	10
<b>Product Registration</b> .....	<b>10</b>
<b>Securing Your Safe</b> .....	<b>11 / 13</b>
Mounting Plate Installation .....	12
Mounting Your Safe .....	12
Removing Your Safe .....	13
<b>FAQ</b> .....	<b>14</b>
<b>Troubleshooting</b> .....	<b>15</b>
<b>Customer Support / Warranty</b> .....	<b>16</b>

## Box Contents

Vaultek® Safe  
18650 Rechargeable Lithium-ion Battery  
AC Power Adapter and Charging Cable  
Mounting Plate  
Hardware Mounting Kit  
Owner's Manual / Quick Start Guide  
Backup Keys (2)

## Tutorial Videos

Listed below are some of the various tutorials available at [vaulteksafe.com](http://vaulteksafe.com).

**Installing Your Battery**  
**Change Your Master Code**  
**How to Anchor Your Safe**  
**+ More videos online.**

Visit the Support tab at [vaulteksafe.com](http://vaulteksafe.com) for FAQ, Troubleshooting, and additional Tutorials.

**GET STARTED**

**VAULTEKSAFE.COM/  
SLIDERSERIES-SUPPORT**

**ONLINE TUTORIALS**  
Quick setup help.

## Product Overview

Get to know your Vaultek® SE20.

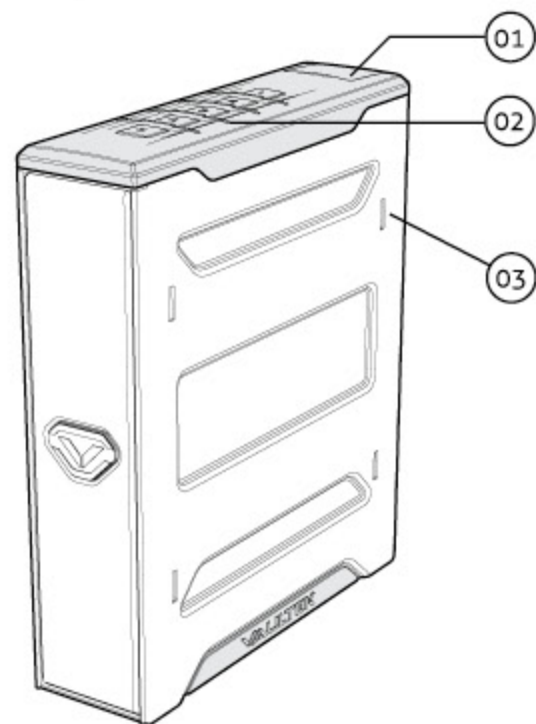

- 01. Key Hole Cover
- 02. Backlit Keypad

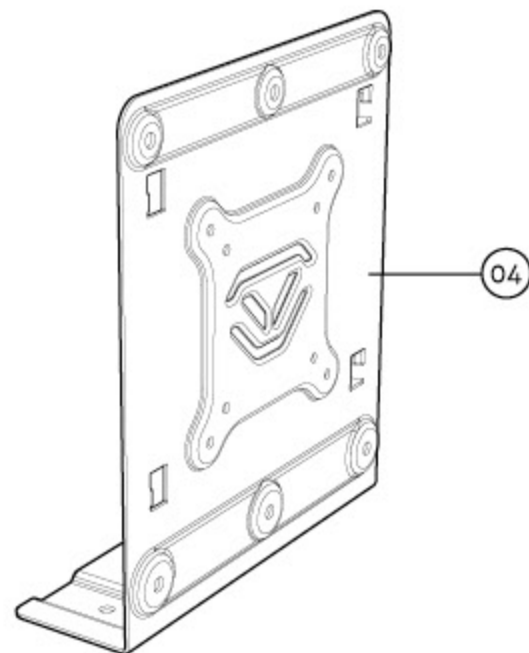

- 03. Mounting Slots (4x)
- 04. Vaultek® Mounting Plate

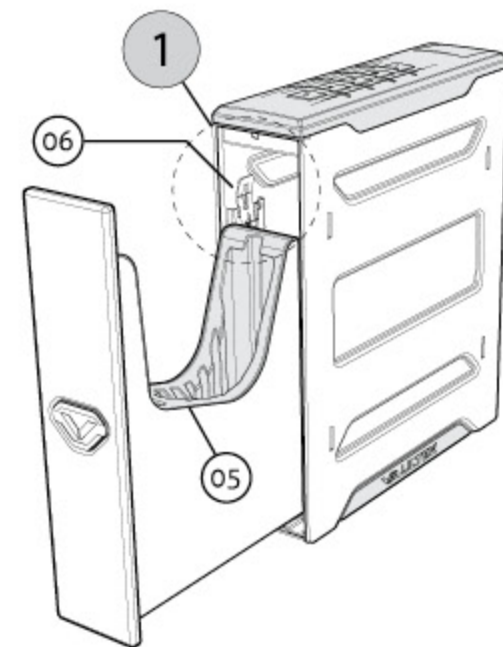

- 05. Pistol Holster with Spare Magazine Slot
- 06. Mounting Plate Release Clip
- 07. LED Light

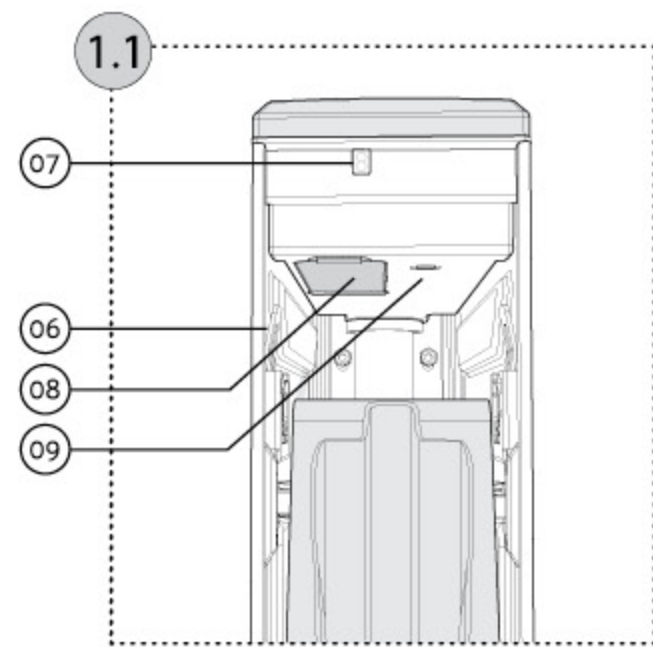

- 08. Battery Compartment Door
- 09. PROGRAM Button



## Introduction

The Vaultek® SE20 is a tough and rugged safe. Its solid structure and penetration resistant design makes it ideal for quick firearm access. Powered by a rechargeable lithium-ion battery, the safe combines high security with complete access control.

**Secure Access** How to open your Vaultek® safe.

**Keypad** The numeric keypad responds quickly for rapid access and has a built-in proximity sensor that lights up when your hand brushes against the safe. See page 08 for more information.

**Key** Two keys are provided for manual access to the safe in the event the battery dies.

**Secure Defense** How your Vaultek® safe keeps people out.

**Anti-Impact Latch** Built to withstand forceful impacts and heavy slams.

**Rugged Construction** Reinforced steel construction helps prevent unwanted tools from attempting to break the safe open.

**Security Sleep Mode** Activates when six (6) consecutive incorrect keypad entries are entered. The safe will not accept any entries for four minutes. If any additional attempts are made the alarm will beep. The security sleep mode can be cleared upon unlock of the safe by any authorized access method including the backup keys.

TUTORIALS ONLINE AT [VAULTEKSAFE.COM/SLIDERSERIES-SUPPORT](http://VAULTEKSAFE.COM/SLIDERSERIES-SUPPORT)

## Warnings

To prevent damage to your Vaultek® unit or injury to yourself or to others, read the following safety precautions before using this unit.

**DO NOT** PLACE OR STORE THE BACKUP KEYS INSIDE THE SAFE AT ANY TIME. IF THE BATTERY FAILS, YOU WILL BE UNABLE TO OPEN THE SAFE.

**DO NOT** expose to extreme heat or cold. Battery power may be affected.

**DO NOT** store loaded guns in this unit. Firearms are serious in nature and must be handled with respect. Store responsibly.

**ALWAYS** check to make sure door has latched when closing; door requires a firm press and locks automatically.

Be sure and follow all local and state firearm laws.

**DO NOT** operate a firearm without proper training and experience.

### DISCLAIMERS:

NEITHER SELLER NOR MANUFACTURER SHALL BE LIABLE FOR UNAUTHORIZED ACCESS, ANY INJURY, LOSS OR DAMAGE TO PERSONAL PROPERTY DIRECT OR CONSEQUENTIAL, ARISING OUT OF THE USE OF, OR THE INABILITY TO USE THE VAULTEK® SAFE.

THE USER SHALL DETERMINE THE SUITABILITY OF THE VAULTEK® SAFE BEFORE THE INTENDED USE AND USER ASSUMES ALL RISK AND LIABILITY WHATSOEVER IN CONNECTION THEREWITH. VAULTEK® SAFES ARE NOT INTENDED TO PROTECT AGAINST ENVIRONMENTAL HAZARDS INCLUDING FIRE AND WATER.

TUTORIALS ONLINE AT [VAULTEKSAFE.COM/SLIDERSERIES-SUPPORT](http://VAULTEKSAFE.COM/SLIDERSERIES-SUPPORT)

## Battery Operation

Your safe uses a 3.7V 18650 rechargeable lithium-ion with a flat top. A minimum 2000 mAh capacity is required, however 2200 mAh or higher can be used to increase operation time. A high capacity battery upgrade is available as an accessory through our website.

### Battery Installation

- 1 To get started open the safe using one of your backup keys via the keyhole at the back of the safe. Open keyhole cover, push key in and rotate key clockwise to open the safe.
- 2 Locate the battery door and open by depressing the tab near the front of the cover, allowing the door to fold down (FIGURE A/B).
- 3 Snap the battery (included in accessory box) into the battery door (FIGURE B/C). The battery door has molded snaps for the battery to clip into. Note that your Vaultek® safe automatically detects the polarity of the battery and can be snapped in either direction.  
**TIP!** Make sure to push battery to back of the battery door allowing the door to close properly.
- 4 Close the battery door. When the battery door is closed you will hear a short welcome tone and the keypad will light up.

**IMPORTANT: First time users should change the default code immediately after installing the battery to prevent unauthorized access to your safe.**



FIGURE A



FIGURE B



FIGURE C

### Charging the Battery

Your Vaultek® safe is powered by a rechargeable lithium-ion battery and comes with a charging kit which includes an AC power adapter and a micro-USB cable. Safe and micro-USB cable can be used with all international power adapters. Under normal usage, a fully charged battery can last at least 3 months.

- 1 **To recharge the safe**, plug the micro-USB cable into the micro-USB receiving jack located on the back side of the safe (FIGURE D) and connect to a standard USB port or wall outlet using the AC power adapter. Approximate recharge time is 2.5 hours.
- 2 The LED next to the receiving jack on the back of the safe (FIGURE D) will glow RED indicating charging and GREEN indicating charged.

### Charging TIPS

- A After installing the battery, use the charging kit provided to charge the unit 100%.
  - B The charging kit can also function as an external power supply, which means you can open your safe even when the battery is depleted.
  - C Leaving your safe plugged in continually will **not** harm the safe or battery. However, to preserve battery life we suggest that you unplug occasionally to allow the battery to cycle down.
  - D A specially designed Vaultek powerpack is available as a separate accessory to extend operation time.
  - E The adapter used to charge the battery should output 5V/2000mA or above when using micro-USB cable.
- See the FAQ section for additional information about the battery.



FIGURE D

## Battery Maintenance

### Testing the Battery Power

To check the battery level, press and hold the '5' key on the keypad for 3 seconds. The keys will glow GREEN or RED to indicate the battery level:

Remaining Battery Capacity Level  
If 4 keys glow green: 80%-100%  
If 3 keys glow green: 60%-80%  
If 2 keys glow green: 40%-60%  
If 1 key glows green: 20%-40%  
If 1 key glows red: 10%-20%  
If 1 key blinks red: less than 10%

### Low Battery

If the first key blinks RED several times and you hear several rapid beeps when opening the safe, your battery level is critically low and your safe needs to be charged immediately.

### Soft Reset TIP

In the event the battery dies or a soft reset is performed (battery removal and installation) the safe will restore default settings for interior light, sound, and Alert of Manual Unlock feature. These settings will need to be readjusted, however the master code will not be affected.

### IMPORTANT

Use a 3.7V 18650 rechargeable lithium-ion battery with a flat top. A minimum 2000 mAh capacity is required, however 2200 mAh or higher can be used to increase operation time.

A high capacity battery upgrade is available as an accessory through our website.

The adapter used to charge the battery should output 5V/2000mA or above when using micro-USB cable.

**TUTORIALS ONLINE AT [VAULTEKSAFE.COM/SLIDERSERIES-SUPPORT](http://VAULTEKSAFE.COM/SLIDERSERIES-SUPPORT)**

## Master Code Programming

First time users should change the default code as soon as possible to prevent unauthorized access to your safe.

### TIP: Code Requirements

- Your code can be a minimum of 4 and a maximum of 8 digits. We recommend a code 6 to 8 digits in length using at least one of each key to make it more difficult for someone to guess your code. For your security, the safe will time out and sleep for 4 minutes if 6 incorrect entries are made.
- Two keys cannot be pressed simultaneously.
- Programming a new code will overwrite your previous code.

- 1 Open the safe. With the safe open, press and hold the "PROGRAM" button (3 seconds)(FIGURE E) until all keys turn RED and let go.
- 2 Enter your NEW master code.
- 3 **IMMEDIATELY** Press and hold the "PROGRAM" button a second time (3 seconds) until all keys turn RED and let go.
- 4 Enter your NEW master code a second time.
- 5 **IMMEDIATELY** Press and hold the "PROGRAM" button together a third time (3 seconds) until the safe beeps and all keys turn GREEN and let go. This tone confirms that the code has been reset.

If you make a mistake and the new code will not work, simply start over with step 1.

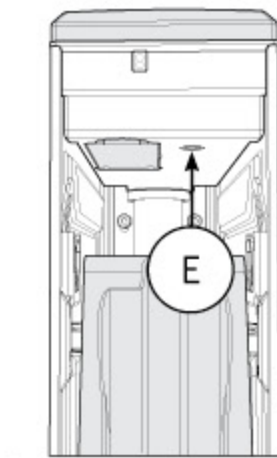

FIGURE E



## Hot Keys

### Tamper Detection

Press and hold '2' and '4'



To check for tampering press and hold keys '2' and '4' together for 3 seconds. The '3' key will glow RED to indicate tampering or GREEN to indicate no tampering. You can reset the tamper detection by opening the safe through one of the authorized entry points.

### Toggle Stealth Mode

Press and hold '1' and '3'



To toggle the sound ON/OFF press and hold keys '1' and '3' together for 3 seconds. If the '2' key glows GREEN and beeps, the sound is ON; if the '2' key glows RED, the sound is OFF.

### Toggle Travel Mode

Press and hold '1'  
'3' and '5'



Save battery life by disabling the proximity sensor and keypad. To toggle travel mode ON/OFF press and hold keys '1' '3' and '5' together until the safe beeps and the keys light up. If the keys glow RED and beeps, the safe is disabled; if the keys glow GREEN and beeps, the safe is operational.

### View Battery Status

Press and hold '5'



To check the battery level press and hold the '5' key on the keypad (3 seconds). Keys from '1' to '4' will glow GREEN or RED to indicate the battery level. See page 07 for more information.

### Interior Light Time Extension

Press and hold '2'



To add additional time to the interior light press and hold the '2' key for 3 seconds. The light will turn on for an additional 10 seconds.

### Toggle Alert of Manual

Unlock Press and hold '3'  
then "PROGRAM"



If the Alert of Unlock is on, and someone opens the safe with either the key or by picking the lock, the keypad will start flashing. To toggle Alert Unlock press and hold the '3' key then "PROGRAM" button together for 3 seconds. The keypad will flash GREEN indicating enabled or RED indicating disabled. If ON and activated it can only be cleared by entering master code. Default is OFF.

### Toggle Interior Light

Press and hold '1'



To toggle interior light press and hold '1' key for 3 seconds. With the light toggled ON it will illuminate when the safe opens.

## Product Registration

Vaultek® strongly encourages you to register your safe as soon as you receive it. **Registration provides many benefits including three year warranty, technical support, and ordering replacement keys should you misplace them.** Your Vaultek® safe has a unique product number on the inside of the battery door and a 4-digit ID number engraved on the keys. You will need these numbers to register your safe.

- 1 Locate your product number. It is printed on the first page of this user manual and on the inside of the battery door (FIGURE F/G).
- 2 Find your 4-digit ID number engraved on the keys (FIGURE H).
- 3 Please visit the Vaultek® website at [vaulteksafe.com](http://vaulteksafe.com) and click Support/Product Registration.
- 4 Enter the required information in the form and click submit.



FIGURE F

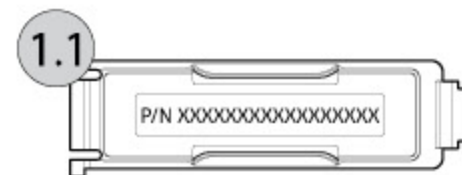

FIGURE G

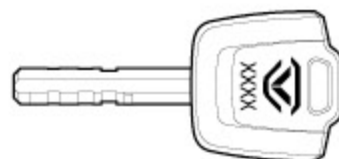
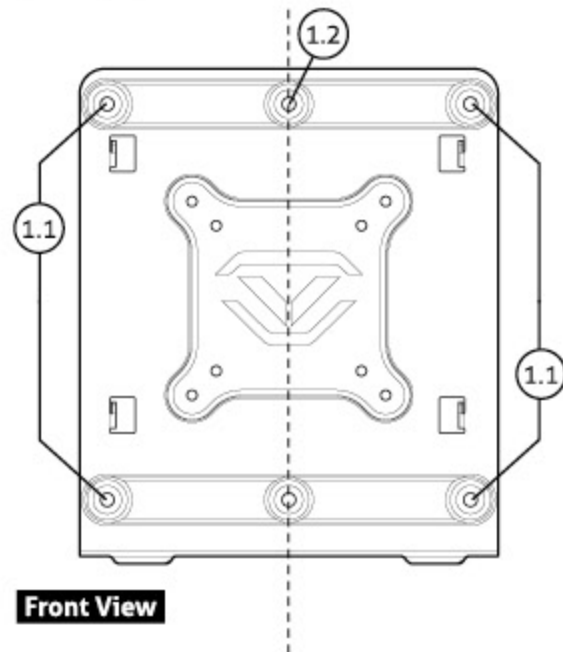

FIGURE H

### Mounting Plate Configurations

Your Vaultek® safe includes a mounting plate with multiple configurations for mounting. A four point configuration can be used for standard vertical surface mounting (1.1), two point mounting for installing in a vertical wall stud (1.2), and base mounts for horizontal applications (1.3).

The mounting plate also features standard VESA 75mm and 100mm fitment for use with other adapter plates (1.4). Hardware for VESA fitment not included.



Front View

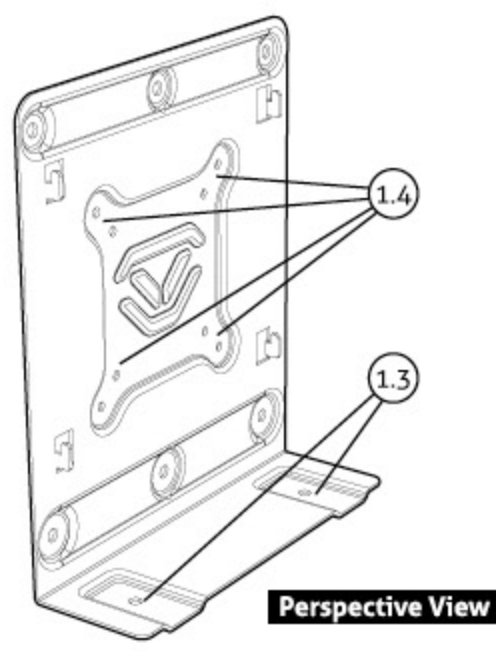

Perspective View

### Installing Mounting Bracket

- 1 Locate mounting surface, making sure the safe will have enough clearance to open properly prior to installing.
- 2 Hold mounting plate in place and use a pencil to mark desired hole locations. Drill 7/32" inch pilot holes.
- 3 Using hardware provided fasten mounting plate in place and tighten firmly.

### Mounting Safe

TIP: Your safe can install on the mounting plate from the left or right side.

- 1 Locate the 4 receiving slots located on the safe sides, and the 4 tabs located on the mounting plate.
- 2 Fully insert the tabs on the mounting plate into the receiving slots on the safe (FIGURE I/J), and press the safe downwards to lock in place (FIGURE K).

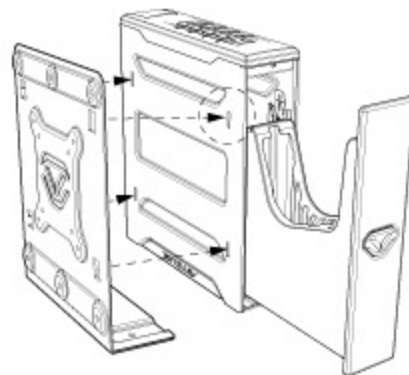

FIGURE I

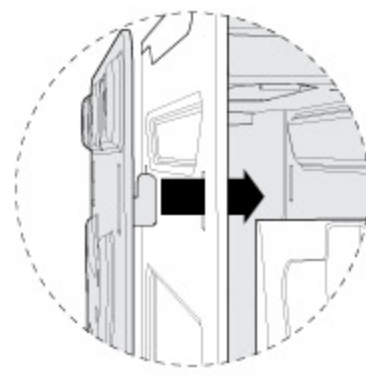

FIGURE J

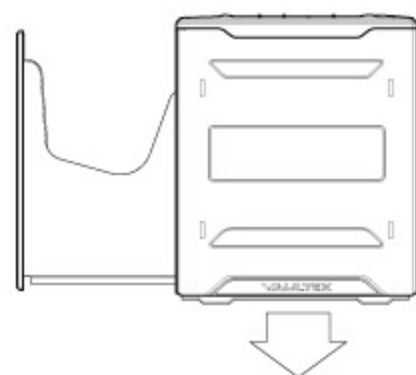

FIGURE K

### To Remove Safe from Mounting Plate

- 1 Open the safe. Locate the release clip on the same side as the attached mounting plate.
- 2 Use your thumb or finger to pull the release clip back, and lift the safe off the mount at the same time (see FIGURE L/M). The safe will not remove without pulling the release clip back.

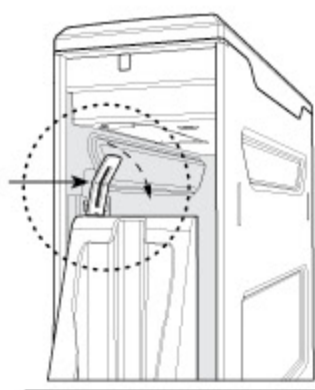

FIGURE L

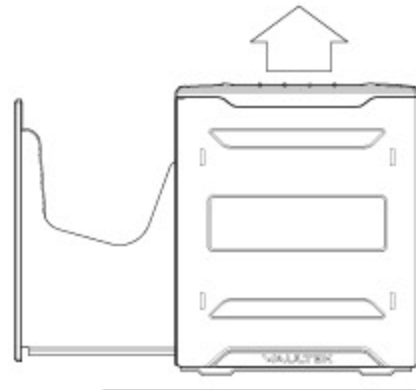

FIGURE M

### Aftermarket Configuration

Your mounting plate features additional pre-drilled holes for the addition of aftermarket brackets or modifications (see FIGURE 1.4 on page 11) using VESA standard fitment. This is great if the environment requires the safe to be configured in a certain manner beyond the standard mounting options available.

**TUTORIALS ONLINE AT [VAULTEKSAFE.COM/SLIDERSERIES-SUPPORT](http://VAULTEKSAFE.COM/SLIDERSERIES-SUPPORT)**

**FAQ** More online at [vaulteksafe.com](http://vaulteksafe.com) under Support

#### **Q: Can I keep the safe plugged in at all times?**

A: Leaving your safe plugged in continually will **not** harm the safe or battery. However, to preserve the battery life we suggest that you unplug occasionally to allow the battery to cycle down.

#### **Q: What happens to the master code that is stored in my Vaultek® safe when the battery dies?**

A: The safe retains the master code in the event of battery failure. Once the power is restored by inserting the AC adapter cable, the unit will function as it did before the power loss.

#### **Q: What type of battery does my Vaultek® safe use?**

A: Use a 3.7V 18650 rechargeable lithium-ion battery with a flat top. A minimum 2000 mAh capacity is required, however 2200 mAh or higher can be used to increase operation time. This type battery is commonly available and higher capacity batteries are available at [vaulteksafe.com](http://vaulteksafe.com).

#### **Q: Can I use a battery of more than 2000 mAh?**

A: Yes, a minimum 2000 mAh capacity is required, however 2200 mAh or higher can be used to increase operation time.

#### **Q: What happens if I lose the keys?**

A: First, make sure you register your safe in the event you do lose your keys. Contact our support team at [vaulteksafe.com/support](http://vaulteksafe.com/support) for assistance. Be prepared to provide your order details and Product Number.

#### **Q: Can I travel with my Vaultek® safe through US Customs or TSA Security at the airport?**

A: Yes, there are no restrictions on carrying this type of item. Please be aware that you may be asked to open your safe rather than passing it through x-ray. We recommend that an authorized user be present during the transport of this item in case such a request is made by a government authority. If transporting a firearm, be sure the safe is checked or included with checked luggage and that you notify your airline agent at check in.

Don't see your question answered.  
Send us your question to [support@vaulteksafe.com](mailto:support@vaulteksafe.com).



If you experience any issues with your safe, try the following solutions.

**The keypad is not responding**

A. Open and close the battery door. This is a soft reset for the safe. See if you are able to open the safe using the keypad or reprogram the safe's master code. If you are still experiencing issues please contact our support at vaulteksafe.com/support for assistance.

**Sound is not working.**

A: To toggle the sound ON/OFF press and hold keys '1' and '3' together for 3 seconds. If the '2' key glows GREEN, the sound is ON; if the '2' key glows RED, the sound is OFF. If the sound is toggled on and you still can't hear it, have someone in your house listen. The tones are high pitch.

**Unable to change master code.**

A: Refer to page 08 of the user manual or check our tutorials online at vaulteksafe.com under Support/Tutorials.

**Soft Reset:** Open and close the battery door. This is a soft reset to the safe. The master code will not be affected.

**STOP!** Do not return to retailer. If you have any questions about your Vaultek® safe or need help configuring the system, please visit Support at vaulteksafe.com.

**Customer Support**

If you have a problem with your Vaultek® safe that is not answered in the FAQ section of this manual, we encourage you to visit [www.vaulteksafe.com/sliderseries-support](http://www.vaulteksafe.com/sliderseries-support).

**Limited Warranty** (Terms and Conditions)

VAULTEK® IS COMMITTED TO PROVIDING PRODUCTS OF HIGH QUALITY AND VALUE AND MAKES EVERY EFFORT TO ENSURE ITS PRODUCTS ARE FREE OF DEFECTS.

Vaultek® guarantees your safe will be free of defects in materials or workmanship for a period of two years from the date of original purchase from an authorized dealer and three years with verified product registration.

The warranty is only valid for the original purchaser and not transferable. This warranty is only valid for products purchased and operated in the U.S. This warranty does not cover abuse, misuse, use in any manner for which is not designed, neglected, modification, damage inadvertently caused by the user, accidents and/or tampering.

If service is needed Vaultek will, at its option, exchange or repair without charge for parts or labor. Upon authorization of warranty service, customers are responsible for securely packaging product. Additionally, customers are responsible for costs of shipping to and from Vaultek service center.

If the claimed defect cannot be identified or reproduced, customers will be held responsible for the costs incurred. Please have the following information available before you begin a claim with Vaultek:

- Purchaser's name, mailing address, email address, and a phone number.
- Copy of receipt or online order number (if purchased directly from us or Amazon)
- Authorized Dealer Name (if applicable)
- Detailed description of the problem

NEITHER SELLER NOR MANUFACTURER SHALL BE LIABLE FOR ANY INJURY, LOSS OR DAMAGE, DIRECT OR CONSEQUENTIAL, ARISING OUT OF THE USE OF, OR THE INABILITY TO USE THE VAULTEK® SAFE.



## FCC

This device has been evaluated to meet general RF exposure requirement, and this device can be used in portable exposure condition without restriction.

### FCC statements:

This device complies with part 15 of the FCC rules. Operation is subject to the following two conditions: (1) this device may not cause harmful interference, and (2) this device must accept any interference received, including interference that may cause undesired operation.

NOTE: The manufacturer is not responsible for any radio or TV interference caused by unauthorized modifications or changes to this equipment. Such modifications or changes could void the user's authority to operate the equipment.

NOTE: This equipment has been tested and found to comply with the limits for a Class B digital device, pursuant to part 15 of the FCC Rules. These limits are designed to provide reasonable protection against harmful interference in a residential installation. This equipment generates uses and can radiate radio frequency energy and, if not installed and used in accordance with the instructions, may cause harmful interference to radio communications. However, there is no guarantee that interference will not occur in a particular installation. If this equipment does cause harmful interference to radio or television reception, which can be determined by turning the equipment off and on, the user is encouraged to try to correct the interference by one or more of the following measures:

- Reorient or relocate the receiving antenna.
- Increase the separation between the equipment and receiver.
- Connect the equipment into an outlet on a circuit different from that to which the receiver is connected.
- Consult the dealer or an experienced radio/TV technician for help.

**TUTORIALS ONLINE AT [VAULTEKSAFE.COM/SLIDERSERIES-SUPPORT](http://VAULTEKSAFE.COM/SLIDERSERIES-SUPPORT)**



**VAULTEK®**

37 North Orange Ave. Suite 800B Orlando, FL 32801

[VAULTEKSAFE.COM](http://VAULTEKSAFE.COM)