

F18 SB



Technical data		2 GROUP 20AMP	2 GROUP 25AMP*	3 GROUP
voltage	V	220-240 1N 50/60Hz or 380-415 3N 50/60Hz		
required amperage	A	20	25	32
power input	kW	4.4	4.9	6.5
steam boiler capacity	lt	12	12	18
steam boiler element	kW	4	4.5	6
pump power	kW	0.15	0.15	0.15
cup-warmer power	kW	0.20	0.20	0.25
net weight	kg	90	90	103

*pre-order only

Features



PRESSURE GAUGE

Allows you to monitor the inlet and pump pressure during extraction.



ELECTRONIC AUTO-LEVEL

Through an electronic auto level probe, the boiler is automatically filled and maintained to the right filling level.

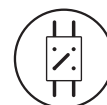

STATIC RELAY BOILER TEMP.

Allows you to accurately regulate the temperature using a PID algorithm.



AISI 316L STAINLESS STEEL "COOL TOUCH" STEAM WAND

Anti-burning feature even in conditions of prolonged use, fitted with "Latte Art" high-performance steam terminals.



LED LIGHTING OF THE WORK AREA

Allows efficient working in any condition of environmental lighting.



PROGRAMMABLE CUP WARMER

High-performance rotary pump for quick and easy adjustment.



MIXED INFUSION HOT WATER FOR TEA

High-performance rotary pump for quick and easy adjustment.



AUTOMATIC CLEANING CYCLE

Process for coffee groups cleaning



EASY SERVICE

Exclusive Sanremo design, with shape and volume designed to capture the best coffee aromas and fragrances.



MULTIFUNCTION DISPLAY

Allows you to monitor the right functioning of the machine and to program the machine's main functions.



PROGRAMMABLE PRE-INFUSION

Control the water that hits the coffee bed with 0.1 sec tolerance, programmed for 4 different profiles for each group.



HIGH-PERFORMANCE VOLUMETRIC PUMP

Pressure stability with prolonged use and simultaneously on more than one group.



GROUP FLUSHING

Fast access to the internal parts, for quick and easy technical service.



COMPETITION FILTERS

Exclusive Sanremo design, with shape and volume designed to capture the best coffee aromas and fragrances.



ENERGY SAVING SYSTEM

Insulation and smart energy management to save up more than 20% of energy.



GROUP SR 61

Chromed brass grouphead with thermosiphonic circulation system, optimised to maintain the ideal coffee extraction temperature.



F18 SB



Versions

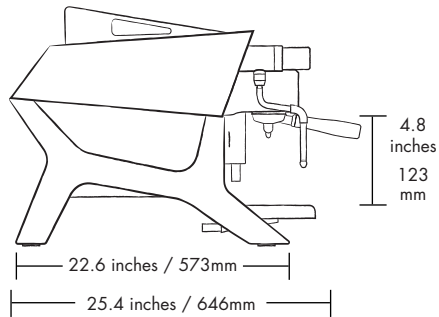

2 GROUP	3 GROUP
2 steam taps	2 steam taps
1 water tap	1 water tap
1 one-cup portafilter	1 one-cup portafilter
2 two-cup portafilters	3 two-cup portafilters

2 GROUP

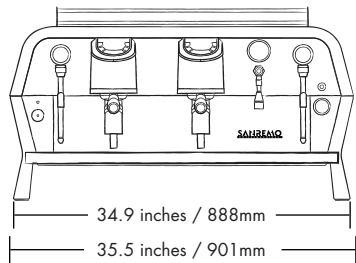

3 GROUP

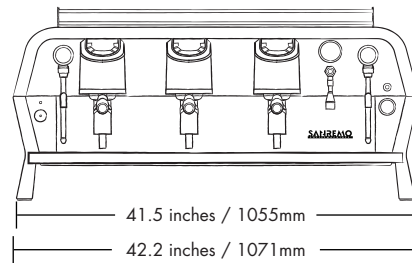

Colours

	Black / Matte Black
	Black / Matte White



All images are subject to illustrative purpose. The manufacturer reserves the right to modify without prior notice the technical characteristics indicated above.

Control Panel

5 SELECTION KEYBOARD

DOSES (1,2)

Single / Double

DOSES (3,4)

Single / Double

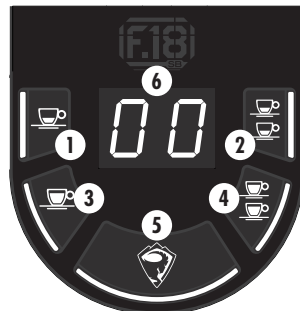

SHOT CLOCK (6)

coffee extraction time

CONTINUOUS DELIVERY /
GROUP FLUSHING (5)

MULTI-FUNCTION DISPLAY

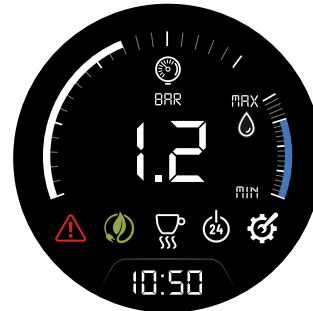

ECO MODE



CONTACT US

info@sanremomachines.com.au
sanremomachines.com.au

